

# 2001 SERVICE PARTS CATALOG

COMMERCIAL  
HUMMER®

## AM GENERAL CORPORATION

408 South Byrkit Avenue  
P.O. Box 728  
Mishawaka, Indiana 46546-0728

AM General Number 5745278  
Copyright ©1999  
All Rights Reserved. Printed in U.S.A.

## TABLE OF CONTENTS

General Information	1
Engine	2
Fuel, Emissions and Exhaust	3
Cooling System	4
Transmission/Transfer Case	5
Wheels and Tires/ Central Tire Inflation System	6
Brake System	7
Steering System	8
Axles/Suspension/Frame	9
Body	10
Heating/Ventilation/ Air Conditioning (HVAC)	11
Electrical	12
Accessories	13
Index	14

# 2001 HUMMER PARTS CATALOG

## TABLE OF CONTENTS 1

**TITLE** **PAGE NUMBER**

### **SECTION 1. GENERAL INFORMATION**

General Information . . . . . 1-1

### **SECTION 2. ENGINE**

Air Intake Manifolds, Crankcase Depression Regulator Valve, and Mounting Hardware. . . . . 2-20  
Camshaft, Timing Chain, and Related Parts . . . . . 2-12  
Crankcase Cover Assembly and Rocker Cover. . . . . 2-14  
Crankshaft, Damper, Bearings, Pulley, and Flywheel . . . . . 2-6  
Cylinder Head and Block Components . . . . . 2-4  
Engine Assembly . . . . . 2-2  
Engine Oil Pan, Pump, and Filler Tube . . . . . 2-16  
Exhaust Manifold Heat Shield . . . . . 2-32  
Exhaust Manifolds . . . . . 2-26  
Mounting Brackets, Engine . . . . . 2-28  
Oil Dipstick and Tube Assembly, Engine. . . . . 2-30  
Oil Filter, Adapter, and Oil Line Fittings . . . . . 2-18  
Piston Assembly, Rod Assembly, and Ring Set . . . . . 2-8  
TurboCharger Assembly . . . . . 2-22  
Vacuum Pump, Serpentine Belt and Accessory Drive Brackets and Pulleys. . . . . 2-24  
Valves, Guides, and Rocker Arm Assemblies . . . . . 2-10

### **SECTION 3. FUEL, EMISSIONS AND EXHAUST**

Accelerator Pedal Assembly . . . . . 3-8  
Air Cleaner, Air Horn, and Related Parts . . . . . 3-10  
Exhaust Pipes and Related Parts . . . . . 3-28  
Fuel Filler Pipe Assembly and Vent Lines, Main Fuel Tank. . . . . 3-20  
Fuel Filler, Auxiliary Fuel Tank . . . . . 3-22  
Fuel Filter Assembly and Mounting Hardware . . . . . 3-26  
Fuel Injection Pump and Fuel Intake Line . . . . . 3-4  
Fuel Injection Supply and Return Lines . . . . . 3-6  
Fuel Pump and Mounting Hardware . . . . . 3-2  
Fuel Supply and Return Lines . . . . . 3-14  
Fuel Tank (Auxiliary) Assembly and Mounting Hardware . . . . . 3-18  
Fuel Tank Vent Line, Filter, and Mounting Hardware . . . . . 3-24  
Main Fuel Tank Assembly and Mounting Straps . . . . . 3-16

# 2001 HUMMER PARTS CATALOG

## 2 TABLE OF CONTENTS

TITLE	PAGE NUMBER
-------	-------------

### SECTION 4. COOLING SYSTEM

Cooling Fan, Fan Clutch, Belt, and Pulleys . . . . .	4-14
Oil Cooler (Engine and Transmission) and Engine Oil Cooler Lines . . . . .	4-16
Radiator and Mounting Hardware . . . . .	4-2
Radiator Hoses and Related Parts . . . . .	4-8
Radiator Shroud and Related Parts . . . . .	4-6
Surge Tank and Related Parts . . . . .	4-4
Thermostat, Water Crossover, and Attaching Hardware . . . . .	4-10
Water Pump and Attaching Hardware . . . . .	4-12

### SECTION 5. TRANSMISSION/TRANSFER CASE/PROPELLER SHAFTS

Control Valve and Related Parts . . . . .	5-14
Torque Converter . . . . .	5-2
Transfer Case Assembly, Front Half . . . . .	5-26
Transfer Case Assembly, Rear Half . . . . .	5-28
Transfer Case Assembly . . . . .	5-24
Transfer Case Oil Cooler Assembly . . . . .	5-32
Transfer Case Shift Controls . . . . .	5-36
Transfer Case Shift Mechanisms . . . . .	5-34
Transmission and Transfer Case Control Assembly and Neutral Start Switch . . . . .	5-5
Transmission External Wiring Harness . . . . .	5-16
Transmission Filter and Sensors . . . . .	5-12
Transmission Mounting Hardware, Fluid Dipstick, and Tube Assembly . . . . .	5-10
Transmission Parking Lock System . . . . .	5-18
Transmission Shifting Linkage . . . . .	5-8
Transmission Vent Lines and Attaching Hardware . . . . .	5-20
Transmission/Transfer Case Cooling Lines . . . . .	5-22

### SECTION 6. WHEELS AND TIRES/CENTRAL TIRE INFLATION SYSTEM

Central Tire Inflation System Routing . . . . .	6-14
CTIS Control Panel and Electrical Harnesses . . . . .	6-8
CTIS Valve Assembly and Compressor . . . . .	6-10
Wheel, Tire and Runflat Assembly, 17", One-Piece Aluminum (Optional) . . . . .	6-6
Wheel, Tire, and Beadlock Assembly, Two-Piece Rim . . . . .	6-4
Wheel, Tire, and Runflat Assembly, Two-Piece Rim . . . . .	6-2

# 2001 HUMMER PARTS CATALOG

## TABLE OF CONTENTS 3

TITLE	PAGE NUMBER
<b>SECTION 7. BRAKES</b>	
ABS Electronic Control Unit (ECU) . . . . .	7-18
ABS Modulator . . . . .	7-12
ABS Wheel Speed Sensor . . . . .	7-16
Brake Lines . . . . .	7-14
Front Service Brake Caliper Assembly and Rotor . . . . .	7-8
Master Cylinder Assembly and Hydro-Boost Assembly . . . . .	7-10
Parking Brake Cables and Mounting Hardware . . . . .	7-4
Parking Brake Hand Lever and Rod . . . . .	7-2
Rear Service and Parking Brake Caliper Assembly and Rotor . . . . .	7-6
Service Brake Pedal Assembly . . . . .	7-20
<b>SECTION 8. STEERING SYSTEM</b>	
Power Steering Gear and Mounting Hardware . . . . .	8-10
Power Steering Gear Assembly . . . . .	8-12
Power Steering Pump, Oil Cooler, and Hydro-Boost Lines and Fittings . . . . .	8-20
Power Steering Pump, Pulley, Reservoir, and Mounting Hardware . . . . .	8-18
Power Steering Pump . . . . .	8-16
Steering Column and Intermediate Shaft . . . . .	8-2
Steering Column Lock and Switch Housing Assembly . . . . .	8-6
Steering Column Trim and Turn Signal . . . . .	8-4
Steering Linkage . . . . .	8-8
<b>SECTION 9. AXLES/SUSPENSION/FRAME</b>	
Airlift Brackets, Front Spring Seats, and Mounting Hardware . . . . .	9-20
Axle Differential, Mounting Brackets, and Hardware . . . . .	9-38
Axle Differential . . . . .	9-40
Bumper, Front and Lifting Shackle (with Winch) . . . . .	9-28
Bumper, Front and Lifting Shackle (without Winch) . . . . .	9-26
Bumper, Rear and Lifting Shackle . . . . .	9-30
Control Arms, Ball Joints, and Mounting Hardware . . . . .	9-12
Frame Rails, Body Mount Brackets, and Transmission Crossmember . . . . .	9-18
Front Suspension Crossmembers, Related Parts, and Mounting Hardware . . . . .	9-6
Front Upper Control Arm Brackets, L.H. . . . .	9-22
Front Upper Control Arm Brackets, R.H. . . . .	9-24
Geared Hub (Knuckle) Assemblies . . . . .	9-50
Halfshaft Assembly, Left and Right Side . . . . .	9-34
Propeller Shafts . . . . .	9-36
Rear Radius Rods . . . . .	9-16
Rear Suspension Crossmembers, Related Parts, and Mounting Hardware . . . . .	9-8
Shock Absorbers and Springs, Front and Rear . . . . .	9-10
Stabilizer Bar and Connecting Links . . . . .	9-14



# 2001 HUMMER PARTS CATALOG

## 4 TABLE OF CONTENTS

TITLE	PAGE NUMBER
-------	-------------

### SECTION 9. AXLES/SUSPENSION/FRAME (Cont'd)

Upper Control Arm Brackets, Spring Seats, Related Parts, and Mounting Hardware . . . . .	9-32
Vent Lines, Front Axle and Geared Hub . . . . .	9-46
Vent Lines, Rear Axle and Geared Hub . . . . .	9-48

### SECTION 10. BODY

B- and C-Bars, Four-Passenger Hardtop and Station Wagon, Models 83 and 84. . . . .	10-72
B-Bar, Two-Passenger Enlarged Cab, Model 89. . . . .	10-70
Body Assembly . . . . .	10-4
Body Assembly Components, L.H. . . . .	10-6
Body Assembly Components, R.H. . . . .	10-8
Body Mounting Components . . . . .	10-2
Door Assembly, Front . . . . .	10-52
Door Assembly, Rear, Models 83, 84, and 90 . . . . .	10-56
Door Striker Assemblies, Front and Rear. . . . .	10-14
Engine Cover, Console Cover, and Related Parts. . . . .	10-48
Fixed Door, Footwell Cover, and Related Parts, Two-Passenger Enlarged Cab, Model 89. . . . .	10-92
Floor Padding, Front and Rear . . . . .	10-112
Four-Door Soft Top Kit, Basic, Model 90. . . . .	10-106
Headliner, Rear Trim and Carpet, Slant-Back, Model 91 . . . . .	10-132
Headliner, Rear Trim, and Carpet, Station Wagon, Model 84 . . . . .	10-130
Headliner, Roof Trim, Front and Rear Side Trim, Grab Handles, and Mounting Hardware (Delco Monsoon Stereo System) . . . . .	10-122
Headliner, Roof Trim, Front and Rear Side Trim, Grab Handles, and Mounting Hardware (Delco Standard Stereo System) . . . . .	10-116
Hood Assembly and Mounting Hardware. . . . .	10-16
Hood Assembly, Grille, and Related Parts . . . . .	10-20
Hood Release . . . . .	10-22
Inner Kick Panels and Miscellaneous Trim Panels . . . . .	10-136
Instrument Panel Assembly, Dash Trim, Crash Pad, and Mounting Hardware . . . . .	10-110
Interior Tunnel Padding, Carpet, and Hardboard. . . . .	10-114
Mirrors (Inside and Outside) and Mounting Hardware . . . . .	10-30
Monsoon Trim Pieces, Model 90 . . . . .	10-128
Outer Kick Panels Interior Trim . . . . .	10-62
Panel Assembly Door Trim . . . . .	10-94
Removable Load Barrier, Station Wagon, Model 84. . . . .	10-108
Roof and Mounting Hardware, Four-Passenger Hardtop, Model 83. . . . .	10-66
Roof and Mounting Hardware, Station Wagon, Model 84 . . . . .	10-68
Roof and Mounting Hardware, Two-Passenger Enlarged Cab, Model 89. . . . .	10-64
Roof, Slant-Back Door, and Mounting Hardware, Slant-Back, Model 91 . . . . .	10-80
Seat Belts, Front and Rear. . . . .	10-44
Seats, Driver and Passenger . . . . .	10-40

# 2001 HUMMER PARTS CATALOG

## TABLE OF CONTENTS 5

**TITLE** **PAGE NUMBER**

### **SECTION 10. BODY (Cont'd)**

Slant-Back Door Latch Assembly . . . . .	10-84
Slant-Back Door Mounting Components And Hinges . . . . .	10-86
Soft Top Support Structure, Model 90 . . . . .	10-99
Splash Shield (Left Hand) and Hood Prop Rod . . . . .	10-24
Splash Shield (Right Hand Upper) and Seals . . . . .	10-26
Splash Shield, Right Hand Lower. . . . .	10-28
Station Wagon Cargo Doors, Power Door Lock . . . . .	10-90
Station Wagon Rear Doors, Model 84 . . . . .	10-75
Sun Visor . . . . .	10-32
Support Structure, Soft Top, Model 90 . . . . .	10-104
Tailgate Assembly and Related Parts . . . . .	10-60
Weathershield, Doors. . . . .	10-96
Window Assembly, Rear. . . . .	10-38
Windshield Assembly . . . . .	10-34
Windshield Washer Reservoir Mounting Support . . . . .	10-12

### **SECTION 11. HEATING/VENTILATION/AIR CONDITIONING**

A/C Compressor and Mounting Hardware . . . . .	11-4
A/C-Heat Vacuum and Temperature Door Motors . . . . .	11-12
Auxiliary A/C-Heat Hoses . . . . .	11-30
Auxiliary A/C-Heat . . . . .	11-26
Auxiliary HVAC Unit . . . . .	11-28
Climate Control Panel . . . . .	11-2
Closeout Panel, Driver's. . . . .	11-20
Closeout Panel, Passenger's. . . . .	11-22
Condenser, Receiver/Dryer, and A/C Hoses . . . . .	11-6
Main A/C-Heat Case Halves and Blower Motor . . . . .	11-14
Main A/C-Heat Evaporator and Heater Core Assemblies . . . . .	11-16
Main A/C-Heat Unit . . . . .	11-10
Plenum and Related Parts . . . . .	11-18
Rear Center Console. . . . .	11-32
Water Control Valve and Heater Hoses. . . . .	11-8
Wiring Harnesses, A/C-Heat . . . . .	11-24

### **SECTION 12. ELECTRICAL**

124-AMP Alternator Assembly . . . . .	12-12
Batteries, Cables, And Mounting Hardware . . . . .	12-4
Clearance Marker Light Assembly. . . . .	12-34
Console Harness Assembly . . . . .	12-100
Cowl Top Harness. . . . .	12-131

# 2001 HUMMER PARTS CATALOG

## 6 TABLE OF CONTENTS

**TITLE** **PAGE NUMBER**

### SECTION 12. ELECTRICAL (Cont'd)

Cross Body Harness . . . . .	12-126
CTIS Interior Harness Assembly . . . . .	12-110
Daytime Running Light Jumper and Harness . . . . .	12-72
Delco Monsoon Stereo System Harness, Hard Top, Models 83 & 84 . . . . .	12-64
Delco Standard Stereo Harness Two-Speaker, Two-Door, Model 89 . . . . .	12-60
Delco Standard Stereo Harness, Four-Speaker, Open Top, Model 90 . . . . .	12-66
Delco Standard Stereo Harness, Four-Speaker, Hard Top, Models 83 & 84 . . . . .	12-62
Door Harness Assembly, Front . . . . .	12-84
Dual Horns . . . . .	12-48
Engine Harness Assembly, AM General . . . . .	12-98
Engine Harness Assembly, GM. . . . .	12-142
Exterior Fuse Box Power Cable . . . . .	12-118
Front Turn Signal Light and Mounting Hardware. . . . .	12-28
Fuse Boxes, Internal & External . . . . .	12-92
Glow Plug Power Cable Assembly . . . . .	12-114
Harness Assembly, Monsoon, Soft-Top . . . . .	12-68
Harness Assembly, Slant-Back Cargo Door, Model 91 . . . . .	12-134
Harness Assembly, Slant-Back Rear Defrost, Model 91 . . . . .	12-136
Harness Assembly, Station Wagon Rear Door Jumper (RH Side). . . . .	12-140
Headlight Assembly and Running Lights . . . . .	12-32
Heated Power Exterior Mirrors . . . . .	12-86
Hood Wiring Harness . . . . .	12-51
Identification Lamp Assembly Jumper . . . . .	12-58
Instrument Panel Cluster . . . . .	12-23
Instrument Panel Harness . . . . .	12-122
Interior Courtesy Lights, Underhood Light, and Door Jamb Switch . . . . .	12-40
Interior Dome Lights . . . . .	12-36
Interior Ground Cable Assembly . . . . .	12-116
Miscellaneous Electrical Items . . . . .	12-146
Monsoon System, Soft-Top . . . . .	12-70
PCM and Digital Ratio Adapter . . . . .	12-144
Power Door Locks . . . . .	12-76
Power Mirror Jumper Harness Assembly. . . . .	12-88
Power Mirror Jumper Harness Assembly, Heated . . . . .	12-90
Power Mirror Switch Harness Assembly . . . . .	12-120
Power Window . . . . .	12-95
Rear Seat Audio . . . . .	12-74
Rear Turn Signal Light/Taillight, License Plate Bracket, and Mounting Hardware . . . . .	12-30
Reflectors . . . . .	12-42
Remote Entry Transmitter and Receiver . . . . .	12-148
Right Front Wheel Sensor Jumper Harness Assembly . . . . .	12-112
Roof Wiring Harness Assembly, Four-Door, Model 83. . . . .	12-106

# 2001 HUMMER PARTS CATALOG

## TABLE OF CONTENTS 7

**TITLE** **PAGE NUMBER**

### **SECTION 12. ELECTRICAL (Cont'd)**

Roof Wiring Harness Assembly, Station Wagon, Model 84 . . . . .	12-108
Roof Wiring Harness Assembly, Two-Door, Model 89 . . . . .	12-104
Roof Wiring Harness, Open Top . . . . .	12-54
Sensors, Sending Units, and Switches . . . . .	12-14
Slant-Back Harness, Model 91 . . . . .	12-138
Starter Motor And Mounting Hardware . . . . .	12-6
Starter Motor Assembly . . . . .	12-8
Stereo, Speakers, and Mounting Hardware, Standard and Monsoon (Delco). . . . .	12-44
Trailer Towing Wiring . . . . .	12-56
Transmission Harness Assembly . . . . .	12-102
Underbody Harness, Rear . . . . .	12-124
Windshield Wiper Motor, Wiper Assembly, and Washer Bottle. . . . .	12-16
Wiper Motor And Blade, Slant-Back Rear Window . . . . .	12-20

### **SECTION 13. ACCESSORIES**

Air Filter Restriction Gauge Kit . . . . .	13-62
Auxiliary Air Hose Kit . . . . .	13-46
Bedliner Kit . . . . .	13-118
Bike Rack Kit . . . . .	13-112
Brushguard Kit and Mounting Hardware . . . . .	13-12
Brushguard Kit, Heavy Duty Accessory Frontal-Coverage . . . . .	13-14
Brushguard Kit, Heavy Duty Accessory Wrap-Around . . . . .	13-16
Bumper (Front with Brushguard and without Winch) Cover Kit, Polished or Brushed Stainless Steel . . . . .	13-102
Bumper (Front with Winch) Cover Kit, Polished or Brushed Stainless Steel . . . . .	13-100
Bumper (Rear) Cover, Polished or Brushed Stainless Steel . . . . .	13-104
Cargo Area Liner, Station Wagon. . . . .	13-54
CD Changer and Remote Control . . . . .	13-84
Dash Trim Appliqué Kit, 1993 - 2000 . . . . .	13-86
Door Handle and Bezel Covers, Polished and Brushed Stainless Steel . . . . .	13-116
Driveline Protection and Mounting Hardware . . . . .	13-28
Driveline Protection Skid Plates . . . . .	13-30
Dual Oil Filter Kit . . . . .	13-94
Electric Seat Heater Kit . . . . .	13-88
Floor Mats . . . . .	13-56
Grille (Front) Cover, Polished or Brushed Stainless Steel . . . . .	13-108
Grille (Upper) Cover, Polished or Brushed Stainless Steel . . . . .	13-106
Hourmeter Kit . . . . .	13-70
Leather Upholstery . . . . .	13-60
Off-Road Accessory Kit, 4-Door Hard Top and 4-Door Soft Top, Models 83 and 90. . . . .	13-92

# 2001 HUMMER PARTS CATALOG

## 8 TABLE OF CONTENTS

TITLE	PAGE NUMBER
<b>SECTION 13. ACCESSORIES (Cont'd)</b>	
Off-Road Accessory Kit, Station Wagon, Model 84. . . . .	13-90
Off-Road Light Kit . . . . .	13-80
Pioneer Tool Kit . . . . .	13-22
Radio Noise Suppression Filter Kit . . . . .	13-72
Rear Defroster. . . . .	13-48
Reflective Triangle Warning Device, Jack Assembly, and Mounting Hardware . . . . .	13-18
Remote Entry Kits . . . . .	13-34
Rocker Panel Guard Accessory Kit. . . . .	13-32
Roof Rack Kit, Aluminum, Round Tube . . . . .	13-124
Roof Rack Kit, Side Load . . . . .	13-114
Roof Rack Kit, Steel, Square Tube . . . . .	13-122
Running Board Kit. . . . .	13-42
Seat Covers. . . . .	13-58
Seat, Auxiliary . . . . .	13-50
Side Step Bars Kit . . . . .	13-44
Ski Rack Kit. . . . .	13-120
Skid Plate Cover, Polished Stainless Steel . . . . .	13-110
Slant-Back (Soft) Kit (Four-Door Soft Top) . . . . .	13-74
Soft Square Back Kit, Model 90 . . . . .	13-76
Spare Tire Carrier Kit, Swing-Away (Steel Wheels Only) . . . . .	13-24
Spare Tire Carrier, Bed-Mounted (Steel Wheels Only) . . . . .	13-26
Tire (Tubeless) Repair Kit, External . . . . .	13-66
Tire (Tubeless) Repair Kit, Internal . . . . .	13-68
Tire Chains . . . . .	13-98
Tire Repair Accessory Kit, External . . . . .	13-96
Tonneau Cover 4-Door Hardtop . . . . .	13-52
Tow Ball Assembly. . . . .	13-10
Traveler's Survival Kit. . . . .	13-64
Universal Roof Mounting Rack Kit. . . . .	13-40
Utility Step . . . . .	13-20
Wheel and Tire Assembly, SpaceSaver Spare . . . . .	13-36
Wheel Cover Kit, Stainless Steel. . . . .	13-82
Wheel, Tire, and Runflat Assembly, One-Piece Aluminum Rim, 16.5" (Optional) . . . . .	13-38
Winch Accessory Kit. . . . .	13-8
Winch Assembly, Mounting Hardware, and Related Parts (Winch Kit) . . . . .	13-3
Winch Assembly . . . . .	13-6
Winch Roller Fairlead . . . . .	13-78

# 2001 HUMMER® PARTS CATALOG

## Section 1 GENERAL INFORMATION

This catalog contains an illustrated list of service or replacement parts for the AM General Commercial Hummer. The Commercial Hummer is equipped with a 6.5L turbocharged diesel engine and is offered in five body styles:

HMC4,	Model 83 — Four-door, four passenger hardtop truck
HMCS,	Model 84 — Four-door, four passenger station wagon
HMCO,	Model 90 — Hard-door, four passenger, open top truck
XLC2,	Model 89 — Two-door, two passenger, enlarged cab truck
HMSB	Model 91 — Four-door, four passenger slant-back truck

This catalog is divided into 13 major sections in the sequence shown on the title page. Major sections are divided into smaller groups of parts, each with its own illustration. Immediately preceding this introduction is a complete listing of all illustrations in this catalog. The first page of each section also contains a listing of illustrations for that section.

Illustrated items are numerically keyed on the illustrations and described in the text on the following page. Figure numbers are located at the top of the description column.

Indented items in the parts listings indicate availability as a part of the preceding assembly. Indented parts with assigned part numbers can also be ordered separately.

Alphabetical and Numerical indexes are located at the end of the catalog (Section 14).

## PARTS SERVICED BY AM GENERAL

AM General will service virtually all of the service or replacement parts for this vehicle except those which are more economical and/or more practical to procure locally. Items not covered may be standard hardware, fuses, lamp bulbs, sealants, lubricants, adhesives, and standard sizes and types of tubing, hoses, and electrical connectors and fittings. Items which are listed in this catalog, but are not serviced, are indicated by the legend "N/S" in the part number column.

## ESSENTIAL TOOLS

All essential tools are covered in the companion service manual. Tools listed with a Kent-Moore part number can be obtained directly from Kent-Moore by calling 1-800-345-2233 or writing to:

Kent-Moore  
28635 Mound Rd.  
Warren, Michigan 48092

## HOW TO LOCATE PARTS

When function, use, or location is known: Refer to the Table of Contents.

When part number is known: Refer to the Numerical Index.

When nomenclature is known: Refer to the Alphabetical Index.

## HOW TO ORDER SERVICE PARTS

Order parts through the Dealer Communication System (DCS). Include the part number and quantity of each part. When entering the part number, be aware that the computer matrix allows for a 2 digit prefix, an 8 digit body and a 4 digit suffix. It is important that you allow for missing digits when entering a part number (e.g. to enter part number G 12345678 you must enter a space before entering the G or the system will misread the part number).

If you encounter difficulty in ordering through the DCS, you may phone the CDCS Help Line at Strategic Business Systems at 201-327-8532 .

HUMMER® is a registered trademark of the AM General Corporation.

## DAMAGED SHIPMENTS, SHORTAGES OR ERRORS

All shipments are properly packed and are in good order when delivered to the transportation company. Responsibility ends with such delivery. When a damaged shipment is received, a claim should be filed immediately against the carrier making delivery.

All claims for shortages or errors in packing must be made to the same address from which the parts were ordered. Claims must be made within ten (10) days after receiving shipment. All claims must be accompanied by the original packing slip, with proper notation of shortage or error, and signed by the responsible person in receiving department.

### ABBREVIATIONS

ABS	Antilock Brake System	mm	Millimeter
AUX	Auxiliary	min	Minimum
A/C	Air Conditioning	N/A	Not Available
A/R	As Required	NPN	No Part Number
baro	Barometric	N/S	Not Serviced
CAD	Cadmium	N.Y.	New York
CW	Clockwise	O.D.	Outside Diameter
CCW	Counterclockwise	PCM	Powertrain Control Module
C.E.	Commutator End	PCV	Positive Crankcase Ventilation
cm	Centimeter	Phos	Phosphate
CTI	Central Tire Inflation	P/N	Part Number
CTIS	Central Tire Inflation System	P/S	Power Steering
D.C.	Direct Current	press.	Pressure
D.E.	Drive End	QTY	Quantity
Dia.	Diameter	R.F.	Right Front
DRA	Digital Ratio Adaptor	R.H.	Right-Hand
EPA	Environmental Protection Agency	R.R.	Right Rear
G.C.C.	Gulf Coast Countries	S.I.A.	Serviced in Assembly
Gr8	Grade 8	S.I.K.	Serviced in Kit
HMC4	Four-Door	S/N	Serial Number
HMCS	Station Wagon	S.P.D.T.	Single Pole Double Throw
HMCO (hard doors)	Open Vehicle	S.P.S.T.	Single Pole Single Throw
HMSB	Slant-Back	S.R.E.	Slip Ring End
hp	horsepower	STD	Standard
HVAC	Heating, Ventilating, Air Conditioning	TCM	Transmission Control Module
I.D.	Inside Diameter	TT4	Torque Trac 4
in.	inch	V	Volt
I/P	Instrument Panel	VIN	Vehicle Identification Number
L.F.	Left Front	VDC	Volt Direct Current
L.H.	Left-Hand	W/S	Windshield
L.R.	Left Rear	XLC2	Two-Door, Enlarged Cab
l.	Liter	ZN	Zinc
max.	Maximum		

### SUGGESTIONS AND RECOMMENDATIONS

Recommendations for improving or correcting this catalog are encouraged. Forms are included at the back of this manual. Please forward corrections or recommendations directly to:

AM General Corporation  
Commercial Publications Department  
408 S. Byrkit St.  
Mishawaka, Indiana 46546-0728

To receive future revisions and updates to this manual, please send the publications form in the front of this manual to:

AM General Corporation  
Commercial Publications Department  
408 S. Byrkit St.  
Mishawaka, Indiana 46546-0728

# VEHICLE IDENTIFICATION NUMBER DESCRIPTION

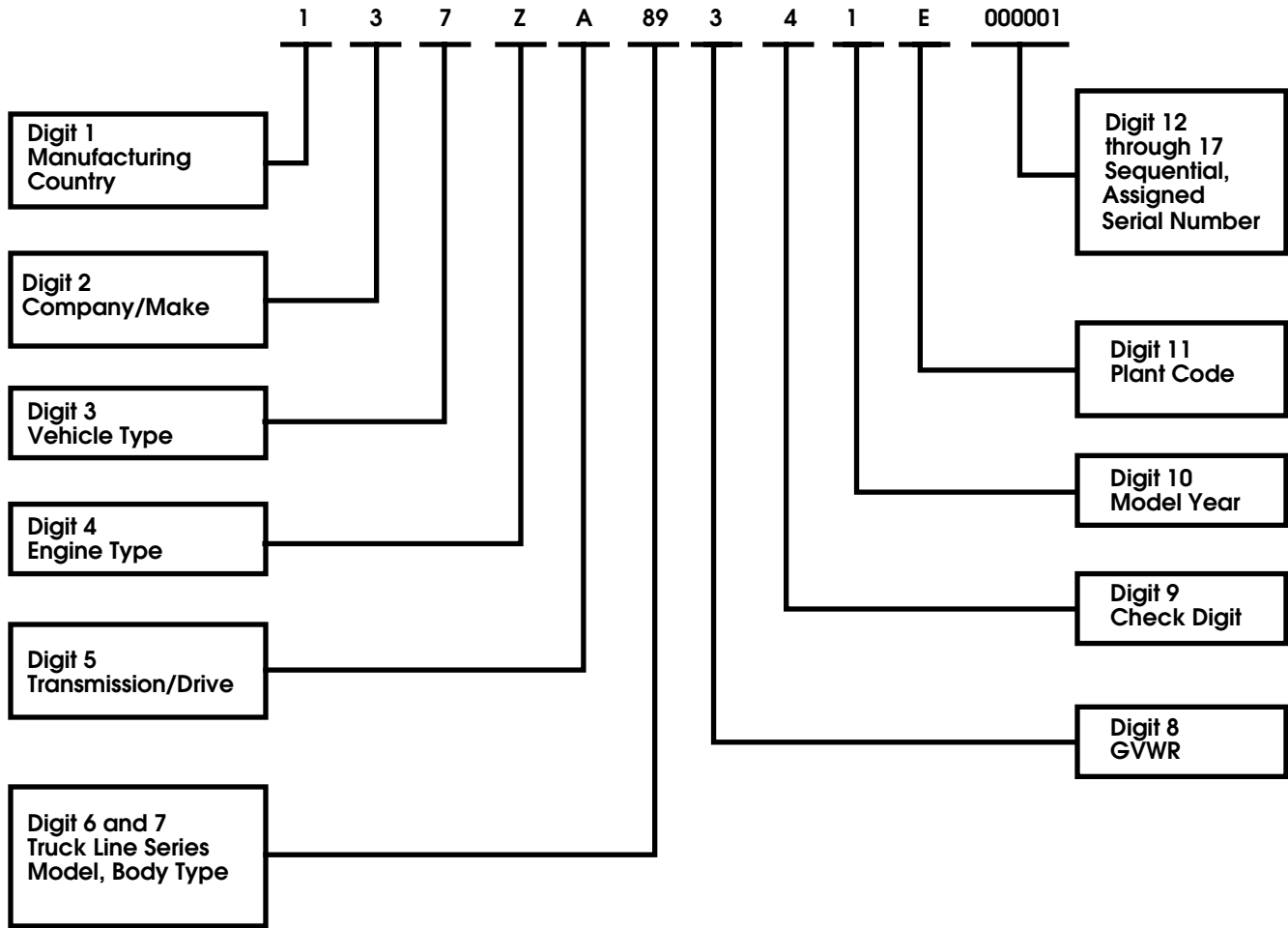

## Vehicle Identification Number Decoding Chart

<u>Digit</u>	<u>Code</u>	<u>Code Definition</u>
1	1	United States
2	3	AM General Corporation
3	7	Commercial Vehicles
4	Z	6.5L Turbocharged Diesel, GM, 8 cyl., 195 hp
	F	6.5L Turbocharged Diesel, GEP, 8 cyl., 195 hp
5	A	4-Speed, Automatic/LHD



## Vehicle Identification Number Decoding Chart (Continued)

<u>Digit</u>	<u>Code</u>	<u>Code Definition</u>		
6 & 7	83	1-1/4 ton	4-door	Truck, utility
	84	1-1/4 ton	Station wagon	Truck, utility
	89	1-1/4 ton	2-door enlarged cab	Truck, utility
	90	1-1/4 ton	Open body w/full hard doors	Truck, utility
	91	1-1/4 ton	4-door slant back	Truck, utility
8	Class 3	10,001 lb - 14,000 lb (4,541 kg - 6,356 kg)		
9	—	Check Digit		
10	1	2001		
11	E	Mishawaka, Indiana		
12-17	—	Sequential Serial Number		

# 2001 HUMMER PARTS CATALOG

## ENGINE 2-1

### Section 2

### ENGINE

TITLE	PAGE NUMBER
Air Intake Manifolds, Crankcase Depression Regulator Valve, and Mounting Hardware . . . . .	2-20
Camshaft, Timing Chain, and Related Parts . . . . .	2-12
Crankcase Cover Assembly and Rocker Cover . . . . .	2-14
Crankshaft, Damper, Bearings, Pulley, and Flywheel . . . . .	2-6
Cylinder Head and Block Components . . . . .	2-4
Engine Assembly . . . . .	2-2
Engine Oil Pan, Pump, and Filler Tube . . . . .	2-16
Exhaust Manifold Heat Shield . . . . .	2-32
Exhaust Manifolds . . . . .	2-26
Mounting Brackets, Engine . . . . .	2-28
Oil Dipstick and Tube Assembly, Engine . . . . .	2-30
Oil Filter, Adapter, and Oil Line Fittings . . . . .	2-18
Piston Assembly, Rod Assembly, and Ring Set . . . . .	2-8
TurboCharger Assembly . . . . .	2-22
Vacuum Pump, Serpentine Belt and Accessory Drive Brackets and Pulleys . . . . .	2-24
Valves, Guides, and Rocker Arm Assemblies . . . . .	2-10

# 2001 HUMMER PARTS CATALOG

## 2-2 ENGINE

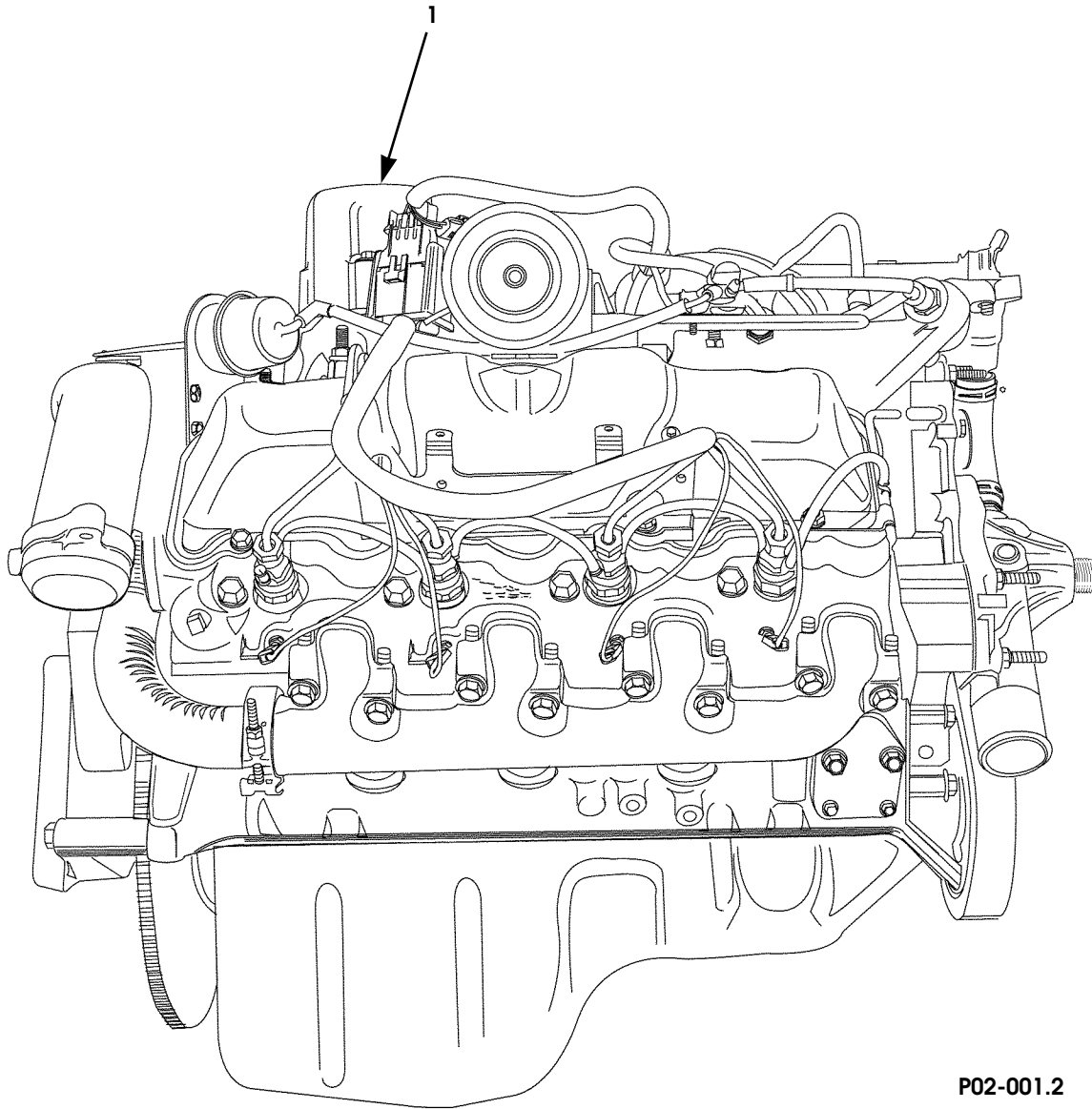

P02-001.2

*Figure 2-1. Engine Assembly.*

# 2001 HUMMER PARTS CATALOG

## ENGINE 2-3

ITEM	PART NUMBER	DESCRIPTION	QTY
1	6011699	<b>Figure 2-1. Engine Assembly.</b>  ENGINE, complete, 6.5 liter, new, SEE NOTE 1 . . . . .	1
1	5744918	ENGINE, long block, 6.5 liter, new. . . . .   NOTE 1: FOR VEHICLES UNDER WARRANTY USE THE LONG BLOCK PART NUMBER 5744918.	1

# 2001 HUMMER PARTS CATALOG

## 2-4 ENGINE

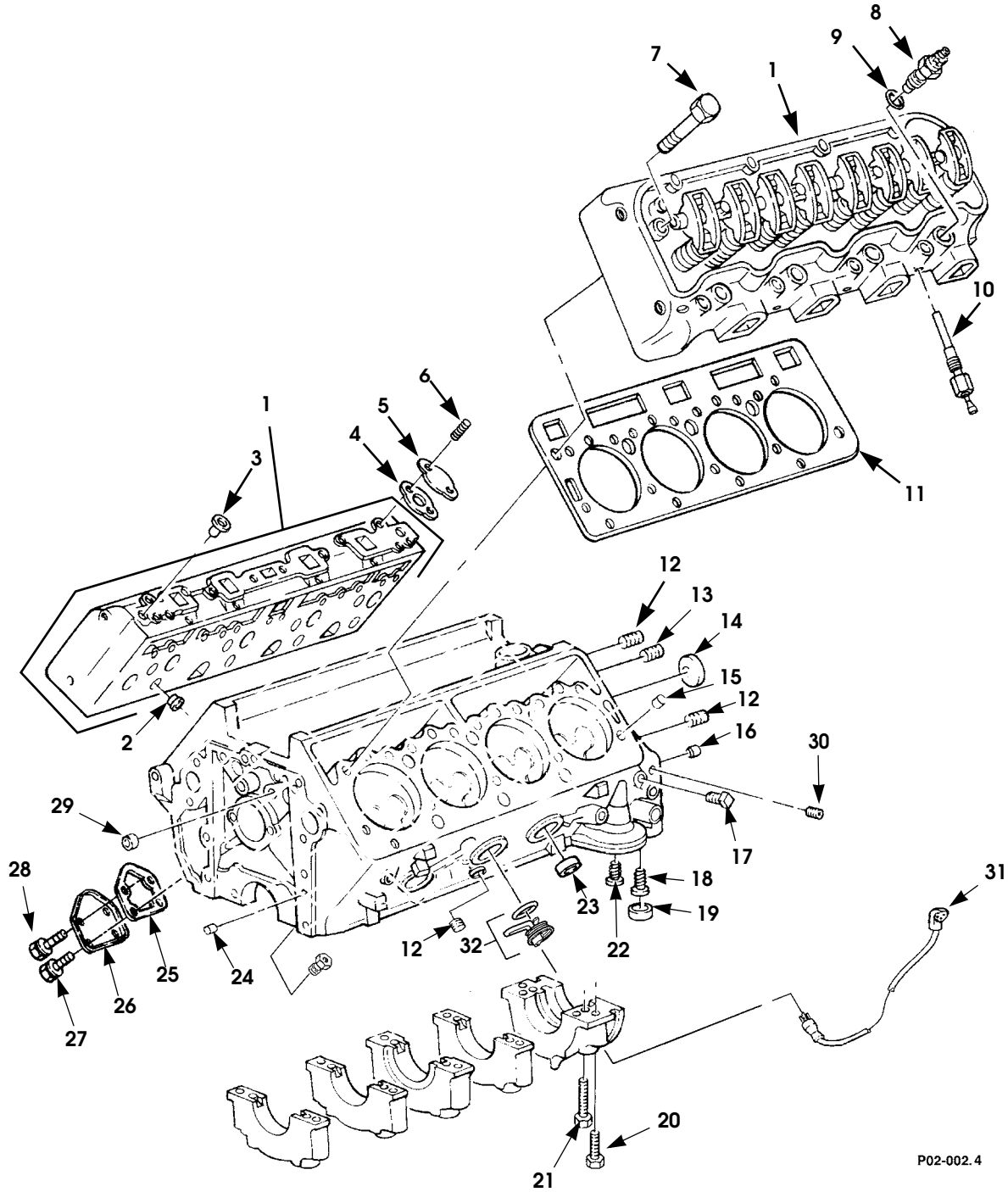

P02-002.4

Figure 2-2. Cylinder Head and Block Components.

# 2001 HUMMER PARTS CATALOG

## ENGINE 2-5

ITEM	PART NUMBER	DESCRIPTION	QTY
		<b>Figure 2-2. Cylinder Head and Block Components.</b>	
1	5744649	CYLINDER HEAD . . . . .	2
1	5745220	CYLINDER HEAD, remanufactured . . . . .	2
2	5744650	•CHAMBER. . . . .	8
2	5744651	•CHAMBER, oversized. . . . .	8
3	5572842	PLUG, cylinder head . . . . .	4
4	5742109	GASKET, water cover . . . . .	2
5	5740186	COVER, water access . . . . .	2
6	12339406-2	STUD, access cover . . . . .	4
7	5740031	BOLT, cylinder head . . . . .	34
8	5743223	NOZZLE, fuel injection . . . . .	8
9	5740058	GASKET, nozzle . . . . .	8
10	5745281	GLOW PLUG, type 60G . . . . .	8
11	5744449	GASKET, cylinder head, SEE NOTE 1 . . . . .	2
12	N/S	PLUG, pipe, 1/4 - 18, oil passage . . . . .	5
13	N/S	PLUG, pipe, 3/8, oil gallery . . . . .	1
14	5740272	PLUG, camshaft . . . . .	1
15	5740268	SPACER, cylinder head . . . . .	4
16	8134398	PIN, flywheel. . . . .	2
17	N/S	PLUG, pipe, 3/8, cylinder block . . . . .	1
18	5743277	VALVE, regulating . . . . .	1
19	5741043	PLUG, regulating valve, oil cooler . . . . .	1
20	5740144	BOLT, bearing cap, outboard, front & rear . . . . .	4
20	5744943	BOLT, bearing cap, outboard, middle . . . . .	6
21	5715343	BOLT, bearing cap, inboard, all . . . . .	10
22	5743278	VALVE, safety . . . . .	1
23	5740529	PLUG, expansion, freeze . . . . .	6
24	5740145	PIN, block . . . . .	2
25	5742650	GASKET, fuel pump cover . . . . .	1
26	5742657	COVER, fuel pump . . . . .	1
27	N/S	SCREW, fuel pump cover, M6 x 1.0 x 16 . . . . .	2
28	N/S	SCREW, fuel pump cover, 3/8 - 16 x 3/4. . . . .	2
29	5741150	PLUG, expansion . . . . .	2
30	5598192	PLUG, cap . . . . .	1
31	5939441	HEATER CORD, block. . . . .	1
32	5743279	IMMERSION HEATER. . . . .	1
		NOTE 1: PART OF GASKET SET P/N 5714842	

# 2001 HUMMER PARTS CATALOG

## 2-6 ENGINE

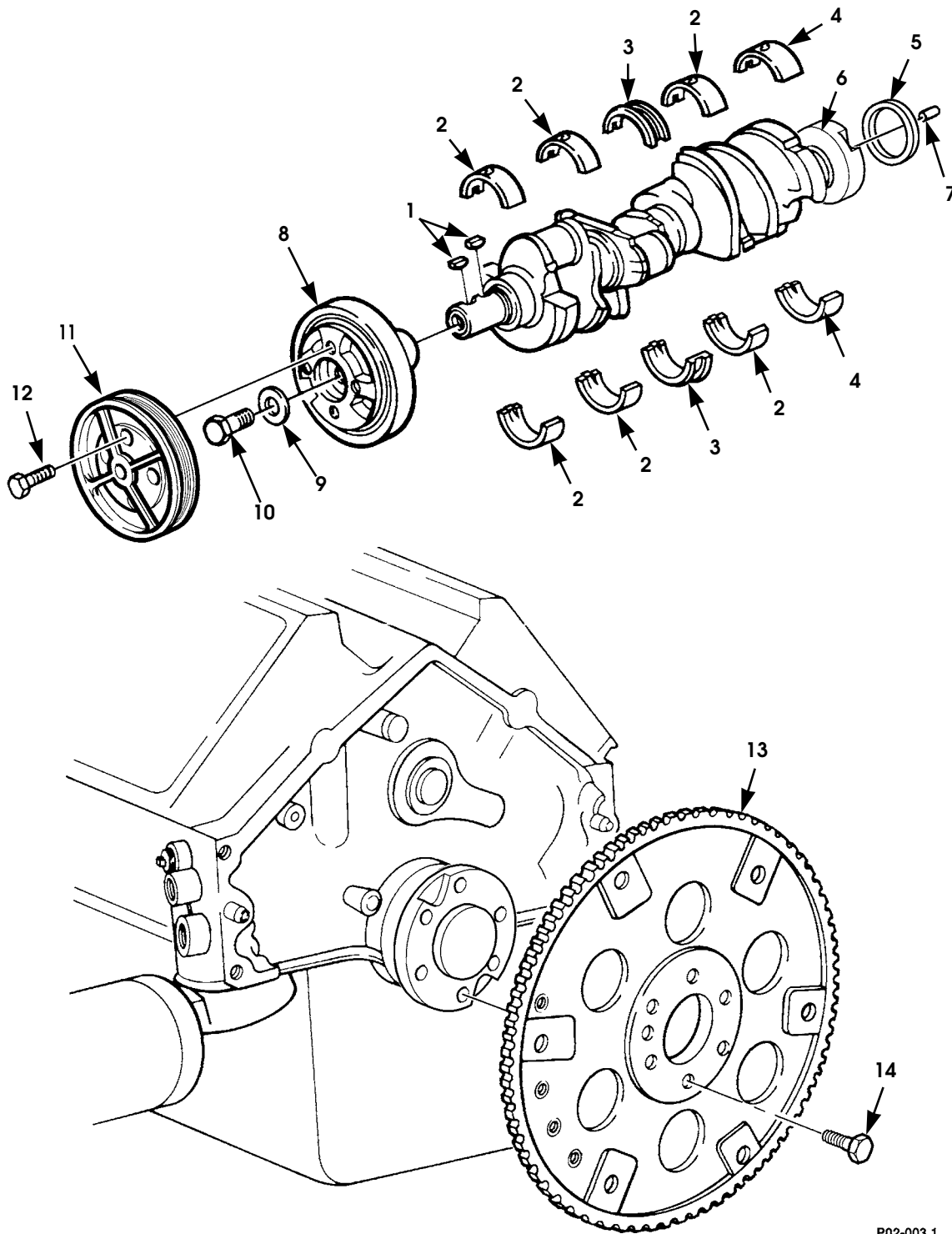

P02-003.1

Figure 2-3. Crankshaft, Damper, Bearings, Pulley, and Flywheel.

# 2001 HUMMER PARTS CATALOG

## ENGINE 2-7

ITEM	PART NUMBER	DESCRIPTION	QTY
		<b>Figure 2-3. Crankshaft, Damper, Bearings, Pulley, and Flywheel.</b>	
1	106751	KEY, crankshaft . . . . .	2
2	5740240	BEARINGS, standard, #1, 2, 4. . . . .	3
2	5740241	BEARING, .013 mm undersized, #1, 2, 4 . . . . .	3
2	5740242	BEARING, .026 mm undersized, #1, 2, 4 . . . . .	3
3	5740201	BEARING, standard, #3 . . . . .	1
3	5740202	BEARING, .013 mm undersized, #3 . . . . .	1
3	5740203	BEARING, .026 mm undersized, #3 . . . . .	1
4	5740204	BEARING, standard, #5 . . . . .	1
4	5740205	BEARING, .013 mm undersized, #5 . . . . .	1
4	5740206	BEARING, .026 mm undersized, #5 . . . . .	1
5	5743226	PACKING, preformed, crankshaft, SEE NOTE 1 . . . . .	2
6	5743227	CRANKSHAFT, engine . . . . .	1
7	5740261	PIN, flywheel . . . . .	1
8	5743228	DAMPER ASSEMBLY, crankshaft . . . . .	1
9	5740147	WASHER, flat, torsional damper. . . . .	1
10	5740146	SCREW, torsional damper . . . . .	1
11	6003069	PULLEY, crankshaft . . . . .	1
12	N/S	BOLT, M10 - 1.5 x 65, crankshaft pulley . . . . .	1
13	5740037	FLYWHEEL, engine . . . . .	1
14	5740263	BOLT, flywheel. . . . .	6
NOTE 1: PART OF GASKET AND SEAL SET P/N 5743399			



# 2001 HUMMER PARTS CATALOG

## 2-8 ENGINE

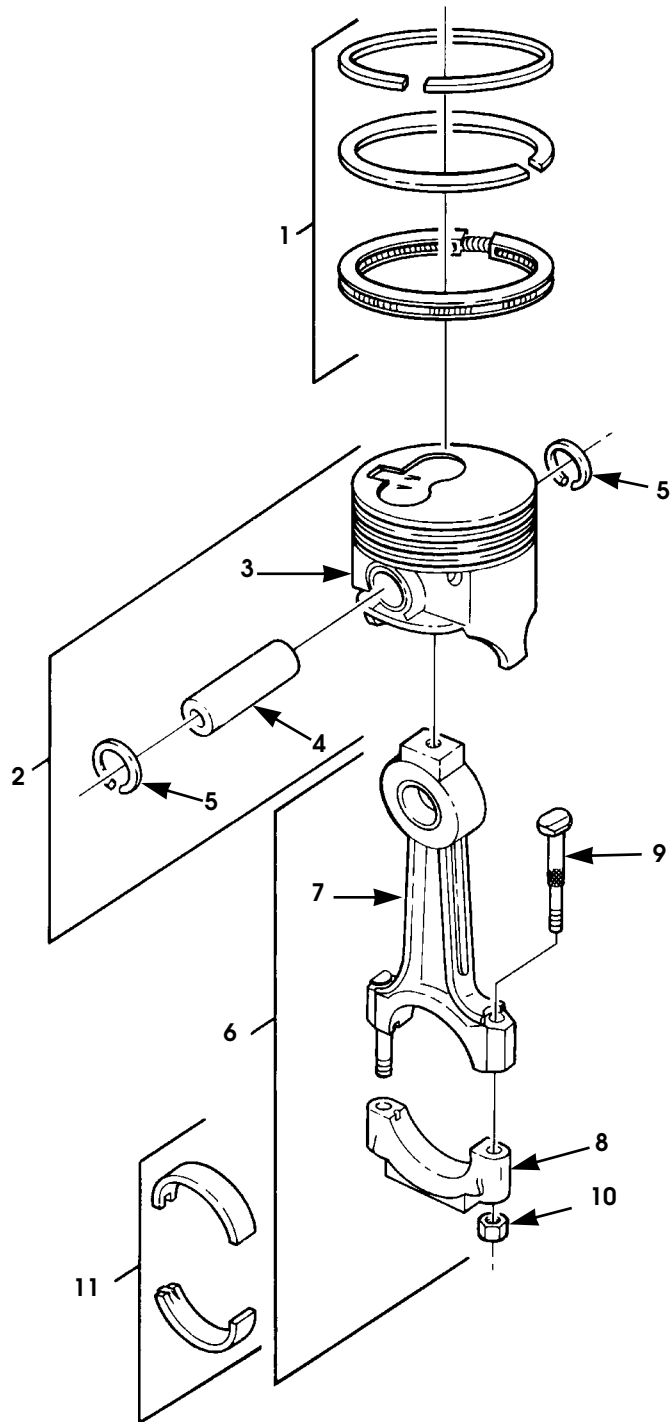

P02-004

Figure 2-4. Piston Assembly, Rod Assembly, and Ring Set.

# 2001 HUMMER PARTS CATALOG

**ENGINE 2-9**

ITEM	PART NUMBER	DESCRIPTION	QTY
		<b>Figure 2-4. Piston Assembly, Rod Assembly, and Ring Set.</b>	
1	5743280	RING SET, standard . . . . .	8
1	5743281	RING SET, 0.5 mm oversized . . . . .	8
2	5743282	PISTON ASSEMBLY, standard . . . . .	8
2	5743799	PISTON ASSEMBLY, 0.5 mm oversized . . . . .	8
3	N/S	•PISTON . . . . .	8
4	N/S	•PISTON PIN . . . . .	8
5	5740158	•RING, retaining. . . . .	16
6	5740038	CONNECTING ROD ASSEMBLY . . . . .	8
7	N/S	•CONNECTING ROD. . . . .	8
8	N/S	•CAP, connecting rod. . . . .	8
9	5740155	•BOLT, connecting rod . . . . .	16
10	5740156	•NUT, connecting rod . . . . .	16
11	5740238	BEARING, connecting rod, standard. . . . .	8
11	5740239	BEARING, connecting rod, 0.026 mm undersized . . . . .	8

# 2001 HUMMER PARTS CATALOG

## 2-10 ENGINE

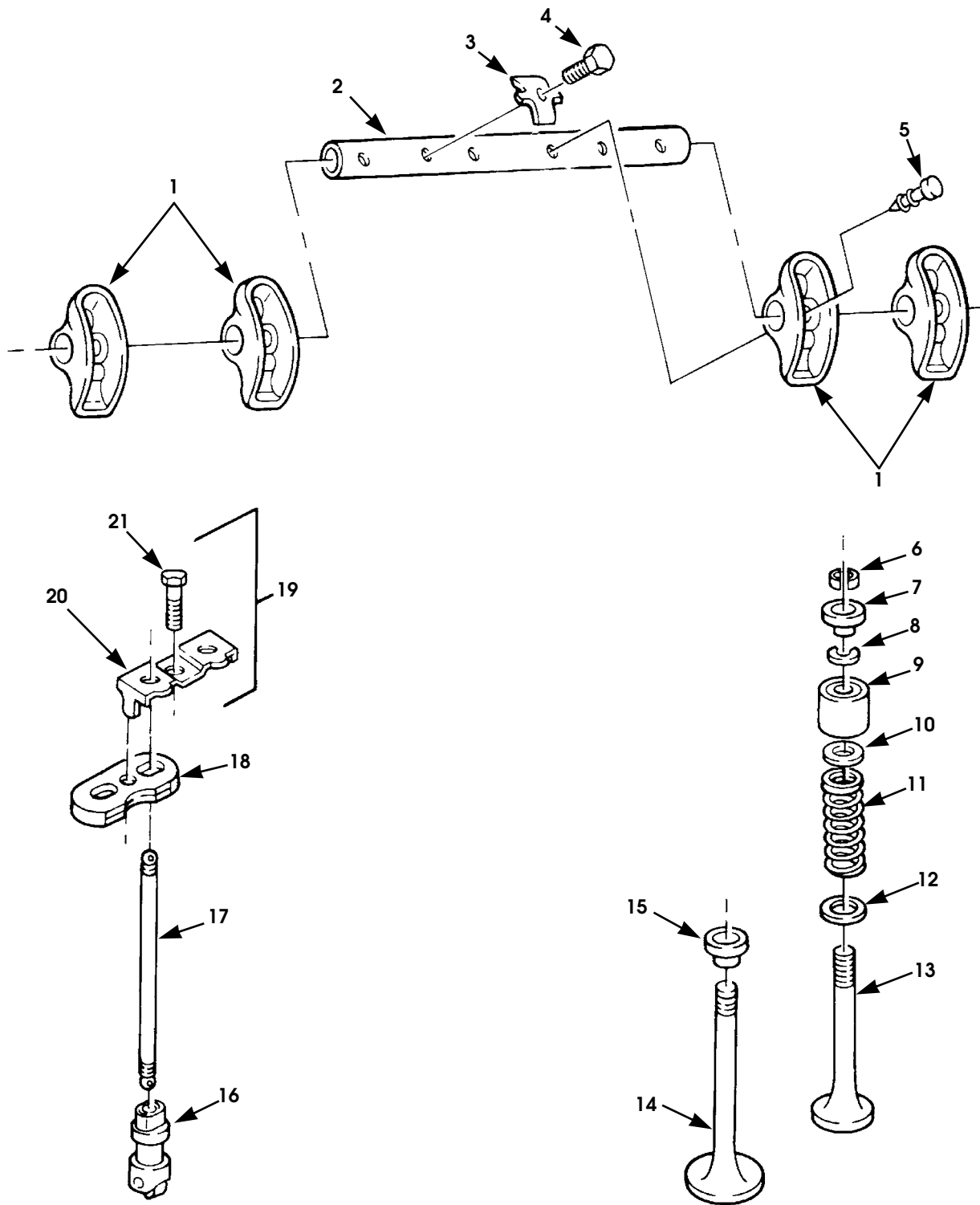

PO2-005

Figure 2-5. Valves, Guides, and Rocker Arm Assemblies.

# 2001 HUMMER PARTS CATALOG

## ENGINE 2-11

ITEM	PART NUMBER	DESCRIPTION	QTY
		<b>Figure 2-5. Valves, Guides, and Rocker Arm Assemblies.</b>	
1	5740132	ROCKER ARM, valve rockers. . . . .	16
2	5740531	SHAFT, valve rocker arm . . . . .	4
3	5741045	RETAINER, rocker arm shaft. . . . .	8
4	11508355	BOLT, rocker arm shaft. . . . .	8
5	5741046	RETAINER, rocker arm . . . . .	16
6	5740270	LOCK, valve spring . . . . .	32
7	5740180	ROTOR, engine poppet, exhaust valve. . . . .	8
8	5740266	SEAL INLET, valve stem, SEE NOTE 1 . . . . .	16
9	5740153	SPACER, sleeve. . . . .	16
10	5742095	SEAL, exhaust valve. . . . .	8
11	5740152	SPRING, valve. . . . .	16
12	5740130	WASHER, valve spring . . . . .	16
13	5743283	VALVE, poppet, exhaust, standard . . . . .	8
13	5743284	VALVE, poppet, exhaust, 0.089 mm oversized . . . . .	8
14	5740041	VALVE, poppet, intake, standard . . . . .	8
14	5740194	VALVE, poppet, intake, 0.089 mm oversized . . . . .	8
14	5740195	VALVE, poppet, intake, 0.349 mm oversized . . . . .	8
15	5740131	CAP, intake valve spring . . . . .	8
16	5740043	TAPPET, hydraulic roller . . . . .	16
17	5740040	PUSHROD, valve. . . . .	16
18	5740133	PLATE, guide. . . . .	8
19	5740134	CLAMP ASSEMBLY, guide . . . . .	8
20	N/S	•CLAMP, guide. . . . .	8
21	N/S	•SCREW, flanged hex head, M8 -1.25 x 22 . . . . .	8
		 NOTE 1: PART OF 6.5L CYLINDER HEAD KIT 5714842	

# 2001 HUMMER PARTS CATALOG

## 2-12 ENGINE

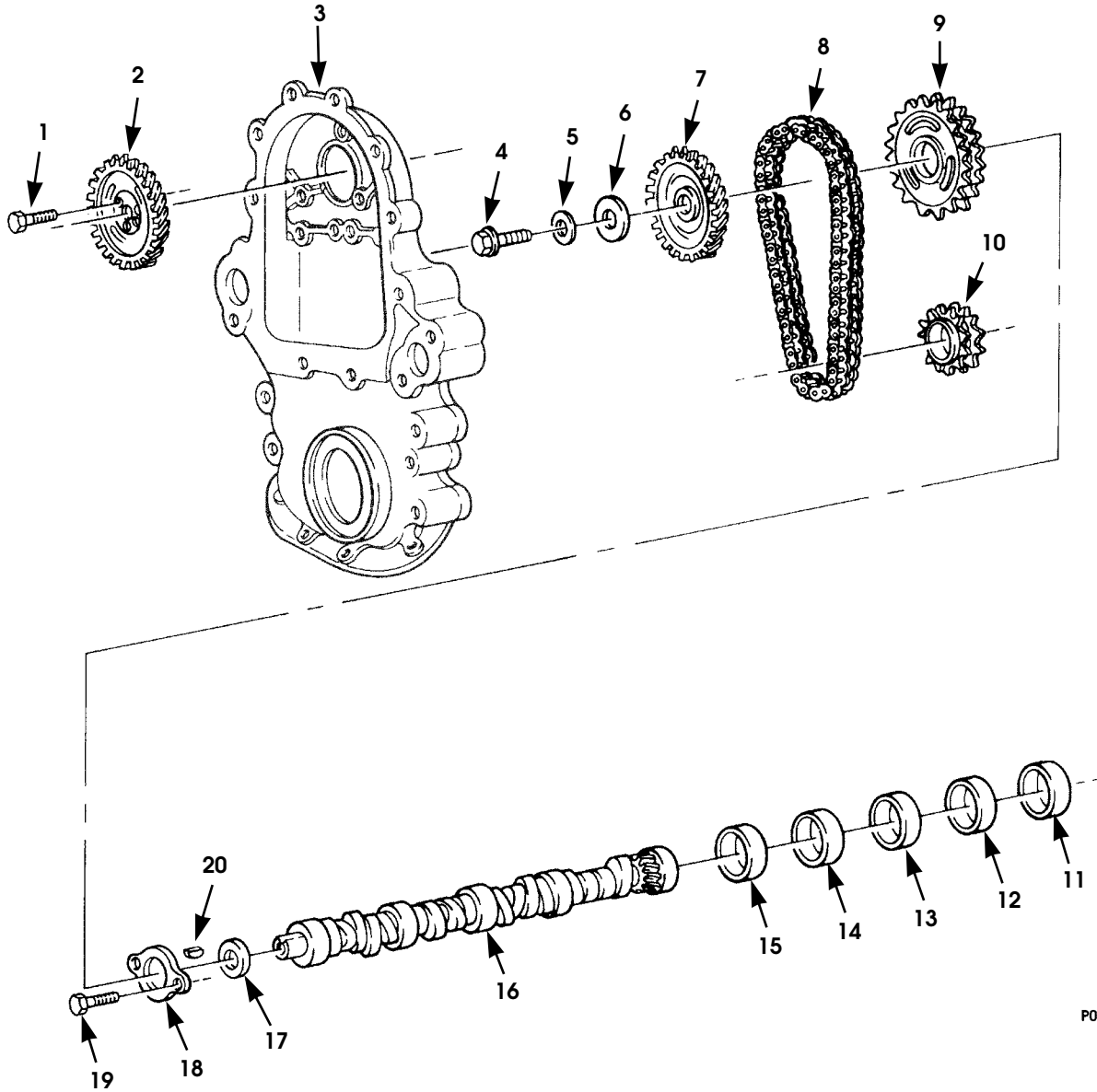

Figure 2-6. Camshaft, Timing Chain, and Related Parts.

# 2001 HUMMER PARTS CATALOG

## ENGINE 2-13

ITEM	PART NUMBER	DESCRIPTION	QTY
		<b>Figure 2-6. Camshaft, Timing Chain, and Related Parts.</b>	
1	5740184	SCREW, fuel injection pump driven gear . . . . .	3
2	5740139	GEAR, fuel injection pump driven . . . . .	1
3	5740182	COVER, crankcase front . . . . .	1
4	5741152	SCREW, pump drive gear . . . . .	1
5	5741151	WASHER, fuel injection pump drive gear . . . . .	1
6	5740137	WASHER, fuel injection pump drive gear . . . . .	1
7	5740140	GEAR, fuel injection pump drive . . . . .	1
8	5740046	CHAIN, camshaft timing . . . . .	1
9	5740044	SPROCKET WHEEL, camshaft . . . . .	1
10	5743229	SPROCKET WHEEL, crankshaft . . . . .	1
11	5740191	BEARING, camshaft, #5, orange . . . . .	1
12	5740190	BEARING, camshaft, #4, green . . . . .	1
13	5740189	BEARING, camshaft, #3, yellow . . . . .	1
14	5740188	BEARING, camshaft, #2, pink . . . . .	1
15	5740187	BEARING, camshaft, #1, plain . . . . .	1
16	5740213	CAMSHAFT, engine . . . . .	1
17	5740135	SPACER, camshaft sprocket . . . . .	1
18	5740136	RETAINER, camshaft . . . . .	1
19	N/S	SCREW, M8 - 1.25 x 16, thrust bearing . . . . .	2
20	106751	KEY, camshaft. . . . .	1

# 2001 HUMMER PARTS CATALOG

## 2-14 ENGINE

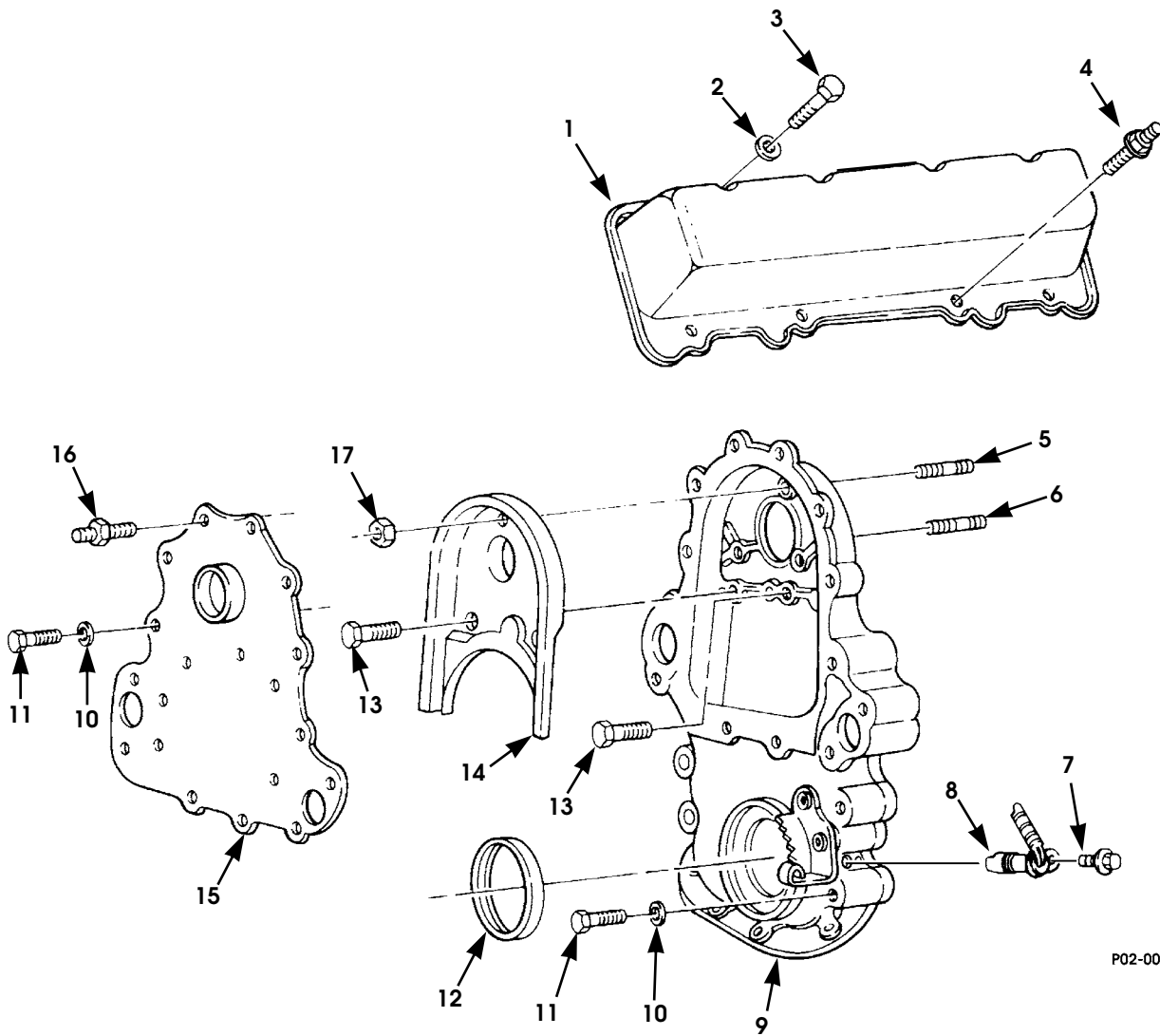

P02-007 .2

Figure 2-7. Crankcase Cover Assembly and Rocker Cover.

# 2001 HUMMER PARTS CATALOG

## ENGINE 2-15

ITEM	PART NUMBER	DESCRIPTION	QTY
		<b>Figure 2-7. Crankcase Cover Assembly and Rocker Cover.</b>	
1	5714138	COVER, rocker arm, R.H. ....	1
1	5740151	COVER, rocker arm, L.H. ....	1
2	5741153	WASHER, rocker arm cover. ....	4
3	11500914	BOLT, rocker arm cover. ....	4
4	5740039	STUD, rocker arm cover. ....	12
5	5740095	STUD, crankcase front cover and injection pump, upper ....	1
6	5742184	STUD, crankcase front cover and injection pump, lower ....	2
7	5744439	BOLT, crankshaft position sensor ....	1
8	5744911	SENSOR, crankshaft position. ....	1
9	5740182	COVER, crankcase front ....	1
10	9438083	WASHER, hard, crankcase front cover ....	4
11	N/S	BOLT, M10 - 1.5 x 55, Class 10.9, crankcase front cover	4
12	5742152	SEAL, crankcase front cover, SEE NOTE 1 ....	1
13	5740181	BOLT, backing plate and front cover ....	2
14	5740169	BAFFLE, crankcase. ....	1
15	5743232	PLATE, water pump backing ....	1
16	5740185	STUD, backing plate and front cover ....	2
17	11514603	NUT, baffle. ....	1
		 NOTE 1: PART OF GASKET AND SEAL KIT 5743399	



# 2001 HUMMER PARTS CATALOG

## 2-16 ENGINE

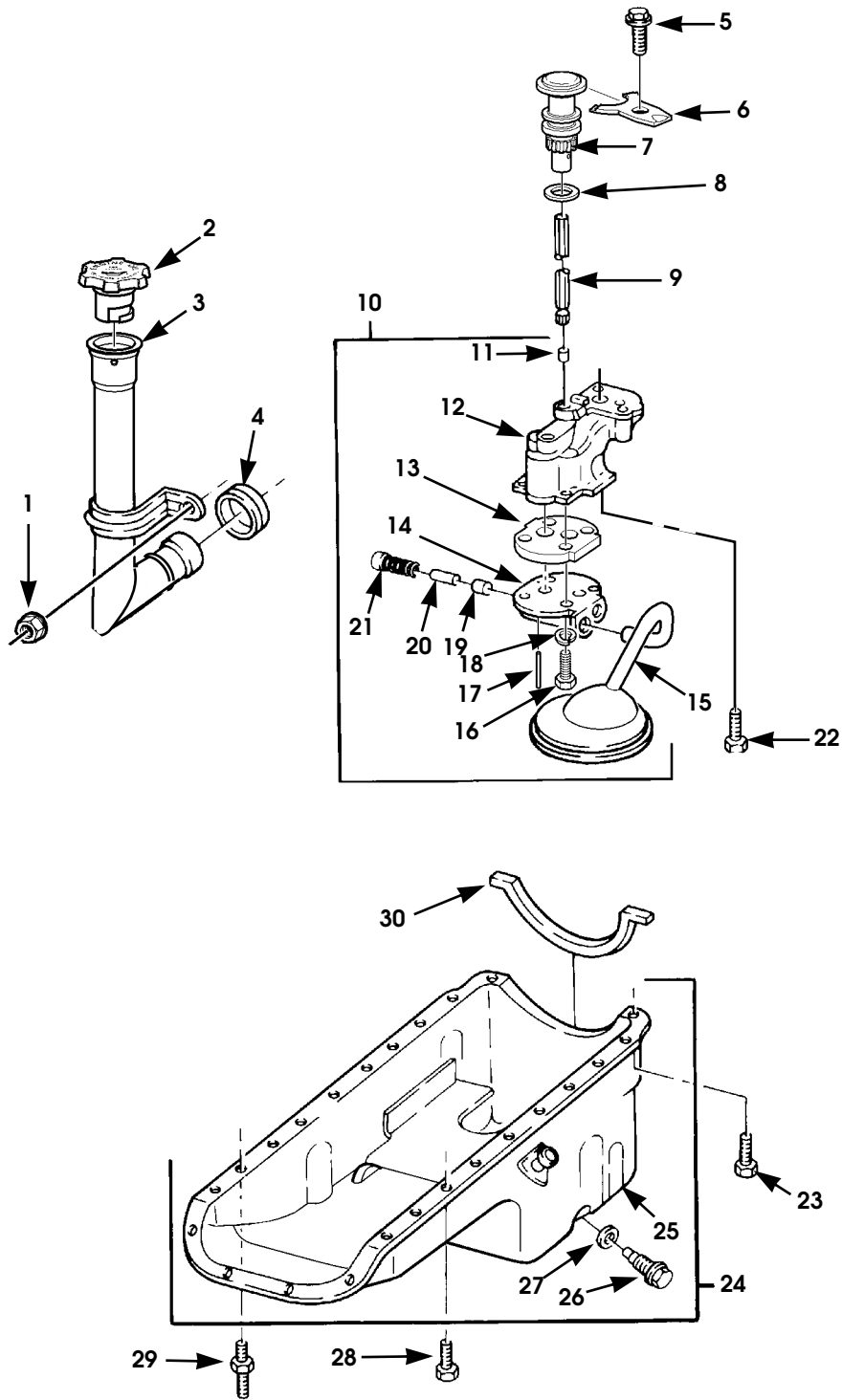

P02-008.4  
(Modified)

Figure 2-8. Engine Oil Pan, Pump, and Filler Tube.

# 2001 HUMMER PARTS CATALOG

## ENGINE 2-17

ITEM	PART NUMBER	DESCRIPTION	QTY
		<b>Figure 2-8. Engine Oil Pan, Pump, and Filler Tube.</b>	
1	N/S	NUT, flanged, M8-1.25, oil filler neck . . . . .	2
2	6009976	CAP, engine oil filler . . . . .	1
3	6009975	FILLER NECK . . . . .	1
4	5740161	GROMMET, oil filler tube . . . . .	1
5	5740181	BOLT, oil pump drive . . . . .	1
6	5740138	CLAMP, oil pump drive assembly . . . . .	1
7	5714669	OIL PUMP DRIVE ASSEMBLY . . . . .	1
8	5740051	GASKET, oil pump drive . . . . .	1
9	5740148	SHAFT, oil pump . . . . .	1
10	5744893	PUMP AND SCREEN, oil pick-up . . . . .	1
11	5740542	•RETAINER, pump assembly . . . . .	1
12	S.I.A.	•PUMP BODY, top . . . . .	1
13	S.I.A.	•SPACER, engine oil pump . . . . .	1
14	S.I.A.	•PUMP BODY, bottom . . . . .	1
15	S.I.A.	•STRAINER, pump assembly . . . . .	1
16	S.I.A.	•BOLT, oil pump cover . . . . .	4
17	S.I.A.	•PIN, regulating valve spring stop . . . . .	1
18	S.I.A.	•LOCKWASHER, oil pump cover . . . . .	4
19	S.I.A.	•DISK, oil pressure regulating valve . . . . .	1
20	S.I.A.	•VALVE, relief, oil pressure . . . . .	1
21	S.I.A.	•SPRING, oil pressure regulating valve . . . . .	1
22	N/S	SCREW, M11 - 1.5 x 66, oil pump assembly . . . . .	1
23	5740085	BOLT, engine oil pan . . . . .	2
24	5744663	OIL PAN ASSEMBLY, engine . . . . .	1
25	N/S	•OIL PAN, engine . . . . .	1
26	5744811	•PLUG, engine oil pan drain . . . . .	1
27	5744812	•GASKET, 12mm, engine oil drainplug . . . . .	1
28	N/S	SCREW, engine oil pan . . . . .	20
29	5591286	STUD, engine oil pan . . . . .	2
30	5743235	SEAL, engine oil pan, rear . . . . .	1

# 2001 HUMMER PARTS CATALOG

## 2-18 ENGINE

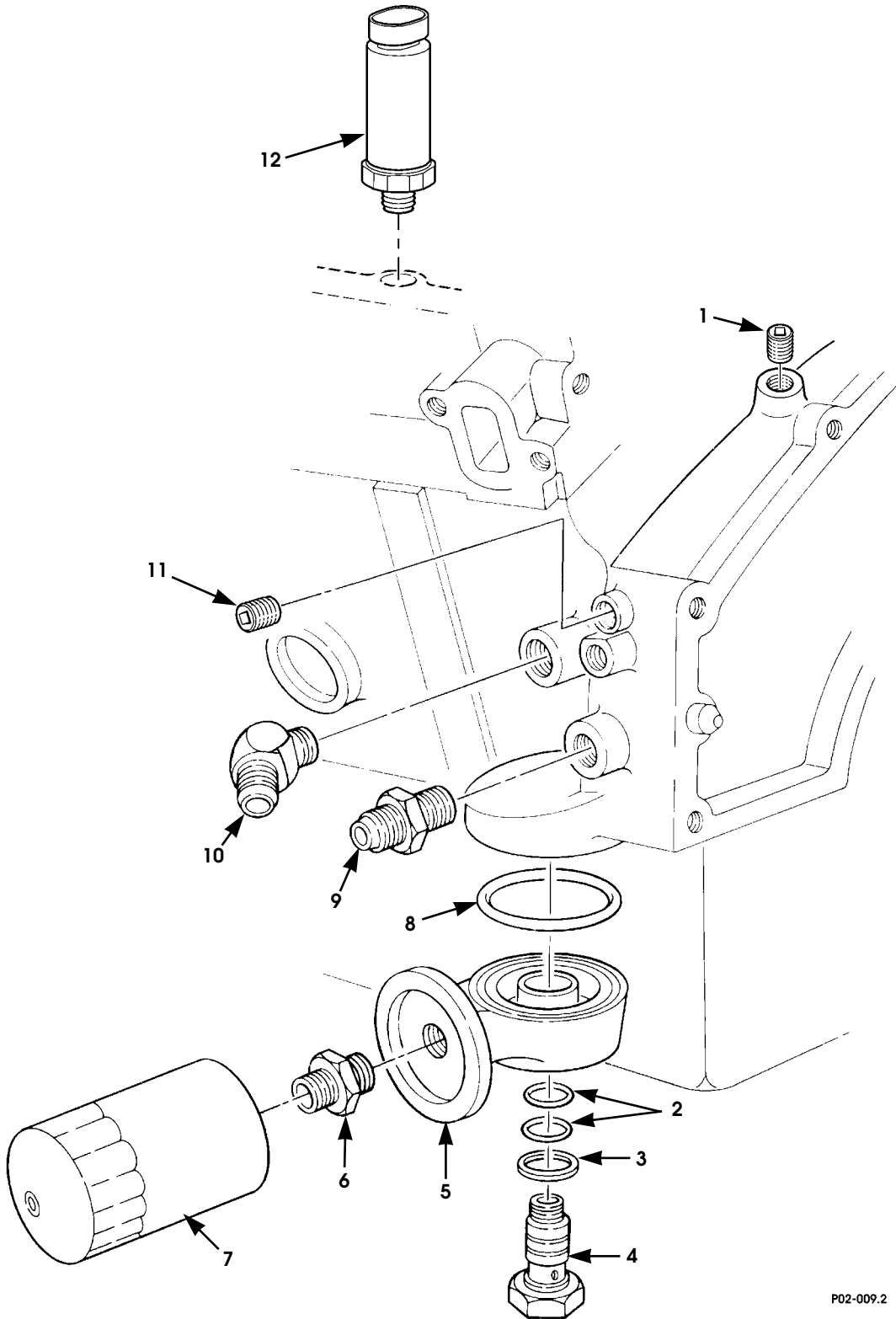

P02-009.2

Figure 2-9. Oil Filter, Adapter, and Oil Line Fittings.

# 2001 HUMMER PARTS CATALOG

## ENGINE 2-19

ITEM	PART NUMBER	DESCRIPTION	QTY
		<b>Figure 2-9. Oil Filter, Adapter, and Oil Line Fittings.</b>	
1	N/S	PLUG, 1/4 - 18 NPT . . . . .	1
2	MS28775-20	O-RING, oil filter adapter bolt . . . . .	2
3	12339409	GASKET, oil filter adapter bolt. . . . .	1
4	12339410	BOLT, fluid passage . . . . .	1
5	12338780	BRACKET, filter mount . . . . .	1
6	12339405	REDUCER, oil filter adapter. . . . .	1
7	5715388	FILTER, engine oil . . . . .	1
8	MS28775-236	O-RING, oil filter adapter . . . . .	1
9	108-70102	STRAIGHT CONNECTOR, oil cooler inlet hose . . . . .	1
10	108-70302	ELBOW, 45 degree, oil cooler outlet hose. . . . .	1
11	N/S	PLUG, 3/8 - 18 NPT . . . . .	1
12	5745120	SENSOR, oil pressure . . . . .	1

# 2001 HUMMER PARTS CATALOG

## 2-20 ENGINE

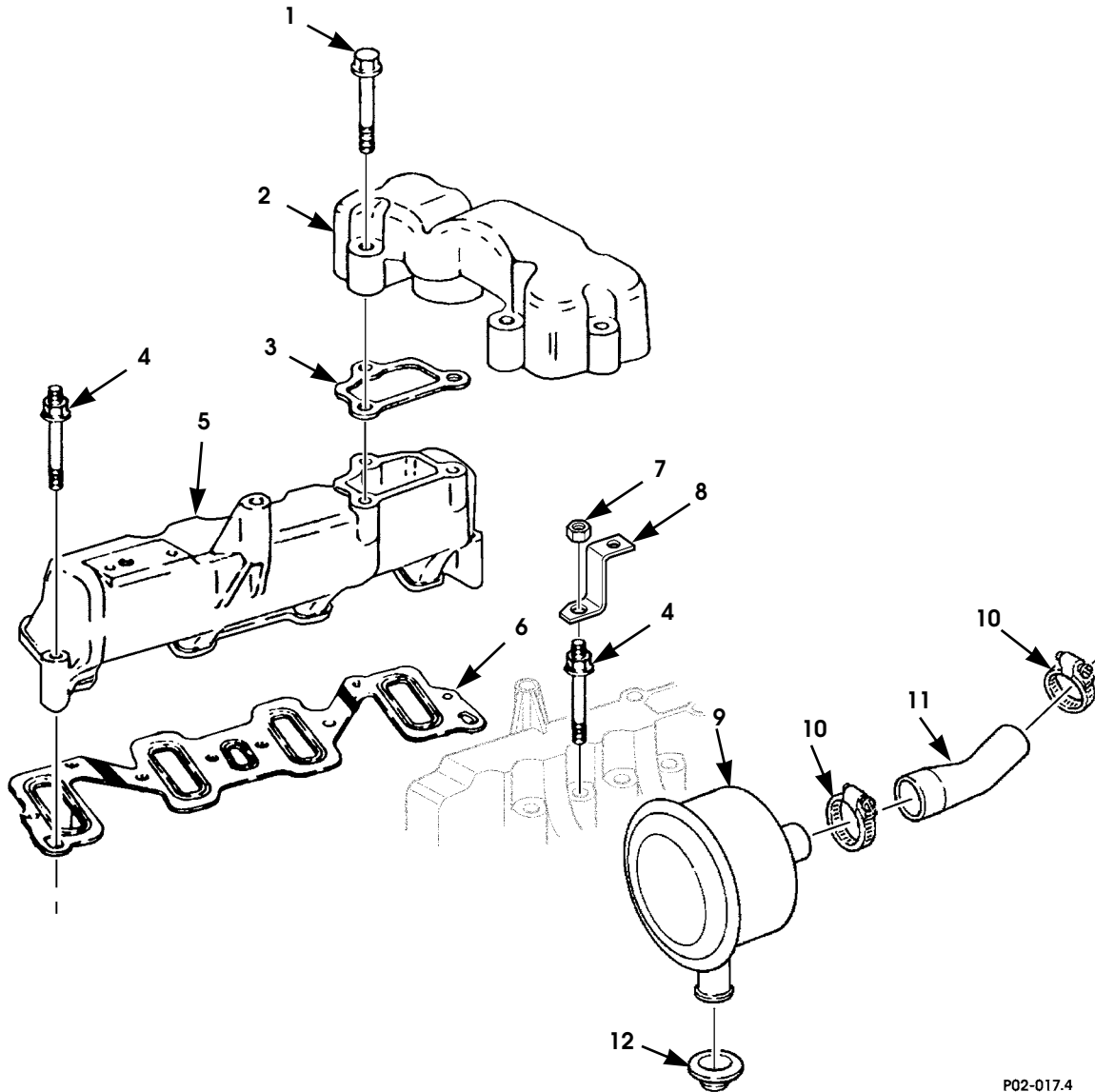

P02-017.4

*Figure 2-10. Air Intake Manifolds, Crankcase Depression Regulator Valve, and Mounting Hardware.*

# 2001 HUMMER PARTS CATALOG

## ENGINE 2-21

ITEM	PART NUMBER	DESCRIPTION	QTY
		<b>Figure 2-10. Air Intake Manifolds, Crankcase Depression Regulator Valve, and Mounting Hardware.</b>	
1	5744435	BOLT, center intake manifold . . . . .	6
2	5744452	INTAKE MANIFOLD, center . . . . .	1
3	5744448	GASKET, center intake manifold . . . . .	2
4	5744459	STUD, intake manifold-to-head . . . . .	16
5	5744453	INTAKE MANIFOLD, L.H. . . . .	1
5	5744454	INTAKE MANIFOLD, R.H. . . . .	1
6	5744451	GASKET, intake manifold-to-head . . . . .	2
7	N/S	NUT, M10 - 1.5. . . . .	1
8	6010103	BRACKET, mounting, engine wire harness connection	1
9	5714132	VALVE, crankcase depression regulator . . . . .	1
10	N/S	•CLAMP, CDR vent hose, 1.50" - 0.62" . . . . .	2
11	6007255	•HOSE, CDR valve . . . . .	1
12	5714133	GROMMET, CDR valve mount . . . . .	1

# 2001 HUMMER PARTS CATALOG

## 2-22 ENGINE

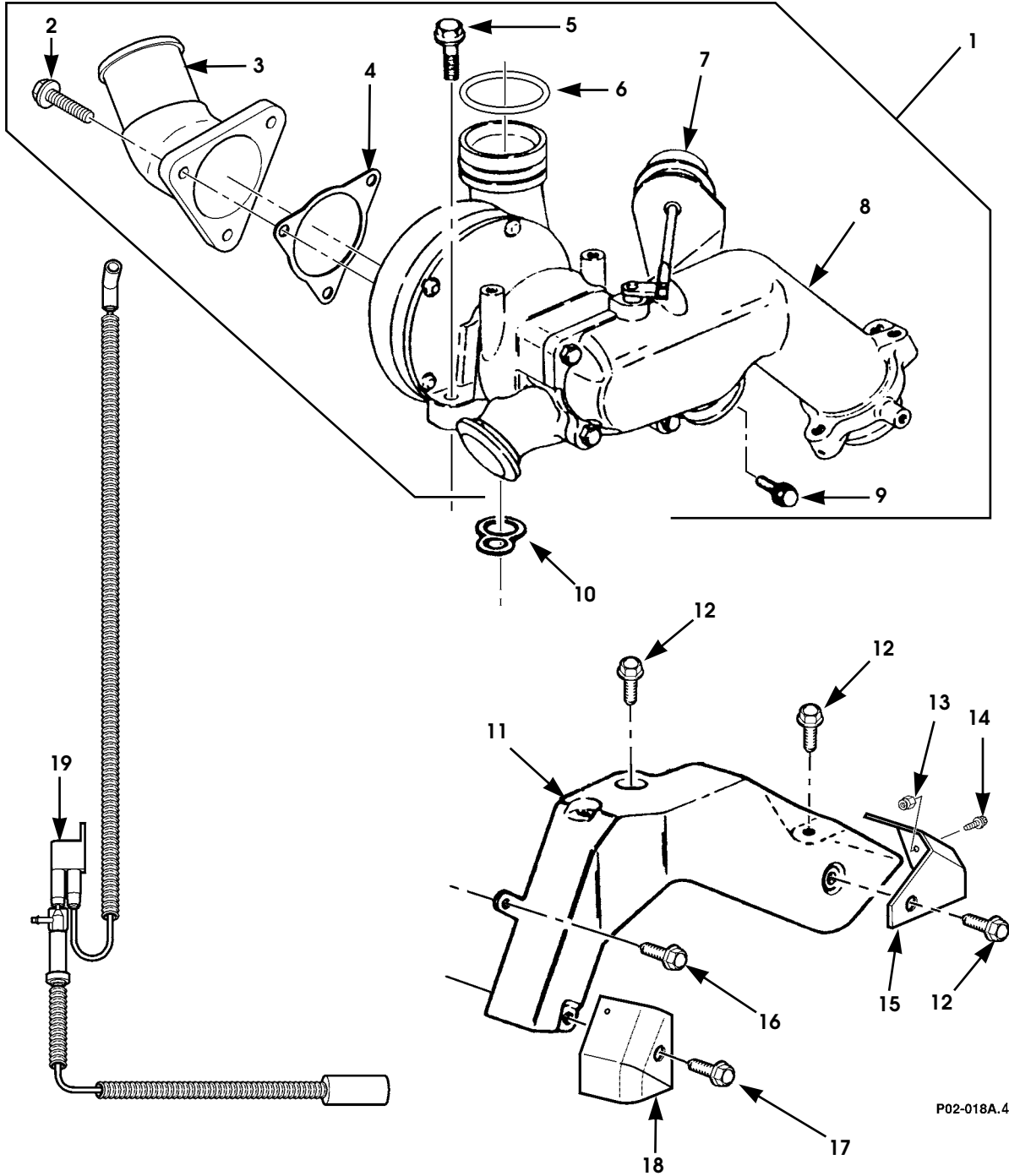

Figure 2-11. TurboCharger Assembly.

# 2001 HUMMER PARTS CATALOG

## ENGINE 2-23

ITEM	PART NUMBER	DESCRIPTION	QTY
		<b>Figure 2-11.</b> <b>TurboCharger Assembly.</b>	
1	5744470	TURBOCHARGER ASSEMBLY, SEE NOTE 1 . . . . .	1
1	5744929	TURBOCHARGER ASSEMBLY, remanufactured . . . . .	1
2	S.I.A.	•CAPSCREW, M8 - 1.25 x 19 . . . . .	3
3	S.I.A.	•INLET ELBOW, turbocharger . . . . .	1
4	S.I.A.	•GASKET, turbocharger inlet elbow . . . . .	1
5	S.I.A.	•BOLT, M10 - 1.5 x 40, turbo-to-block. . . . .	2
6	5745167	•O-RING, turbocharger air intake . . . . .	1
7	5744654	•ACTUATOR, wastegate . . . . .	1
8	S.I.A.	•CASTING, turbocharger body . . . . .	1
9	S.I.A.	•BOLT, M8 - 1.25 x 20 . . . . .	1
10	5745123	SEAL, turbo-to-block . . . . .	1
11	12550114	HEAT SHIELD, turbocharger. . . . .	1
12	N/S	BOLT, M8 - 1.25 x 14, heat shield. . . . .	4
13	N/S	LOCKNUT & LOCKWASHER ASSEMBLY, #6 - 32. . . . .	1
14	N/S	SCREW & LOCKWASHER ASSEMBLY, #6 - 32 x 1/2 . . . . .	1
15	RCSK18089	HEATSHIELD, R.H. . . . .	1
16	N/S	BOLT, M10 - 1.5 x 25, Class 9.8, heat shield . . . . .	1
17	N/S	BOLT, M10 - 1.5 x 20, Class 10.9, heat shield . . . . .	1
18	6007707	HEATSHIELD, L.H. . . . .	1
19	5744652	VACUUM HARNESS BOOST CONTROL . . . . .	1
		NOTE 1: FOR VEHICLES UNDER WARRANTY USE THE REMANUFACTURED TURBO ASSEMBLY, PART NUMBER 5744929.	



# 2001 HUMMER PARTS CATALOG

## 2-24 ENGINE

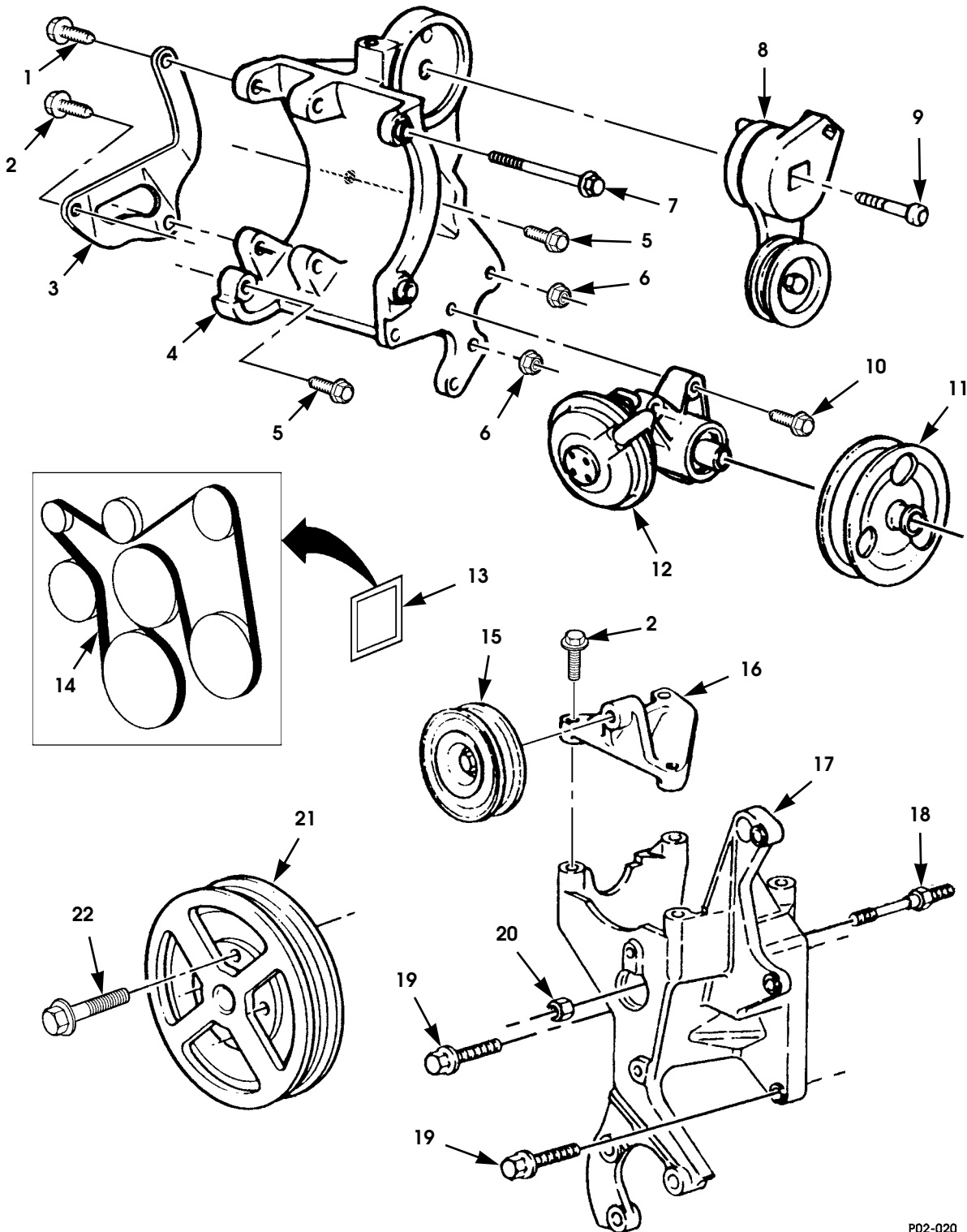

P02-020

Figure 2-12. Vacuum Pump, Serpentine Belt and Accessory Drive Brackets and Pulleys.

# 2001 HUMMER PARTS CATALOG

## ENGINE 2-25

ITEM	PART NUMBER	DESCRIPTION	QTY
		<b>Figure 2-12. Vacuum Pump, Serpentine Belt and Accessory Drive Brackets and Pulleys.</b>	
1	6003067	BOLT, brace . . . . .	1
2	6006783	BOLT, brace . . . . .	4
3	6006773	BRACE, rear generator bracket . . . . .	1
4	6006775	BRACKET, generator-to-engine . . . . .	1
5	11509036	BOLT, flanged, generator bracket . . . . .	2
6	6006989	NUT, generator brace . . . . .	2
7	6006777	BOLT, generator mounting . . . . .	2
8	6003051	TENSIONER . . . . .	1
9	6006802	BOLT, Torx head, tensioner. . . . .	1
10	11515758	BOLT, vacuum pump. . . . .	3
11	6006805	PULLEY, vacuum pump . . . . .	1
12	6006803	VACUUM PUMP . . . . .	1
13	6006813	LABEL, belt routing . . . . .	1
14	6007453	BELT, serpentine . . . . .	1
15	6006811	PULLEY, idler assembly, non-A/C . . . . .	1
16	6006812	BRACKET, idler assembly, non-A/C . . . . .	1
17	6006807	BRACKET, A/C, power steering mounting . . . . .	1
18	6006806	STUD, bracket. . . . .	1
19	6006808	BOLT, bracket . . . . .	2
20	11501850	NUT, bracket . . . . .	1
21	6003069	PULLEY, crankshaft . . . . .	1
22	N/S	BOLT, M10 - 1.5 x 65 . . . . .	4

# 2001 HUMMER PARTS CATALOG

## 2-26 ENGINE

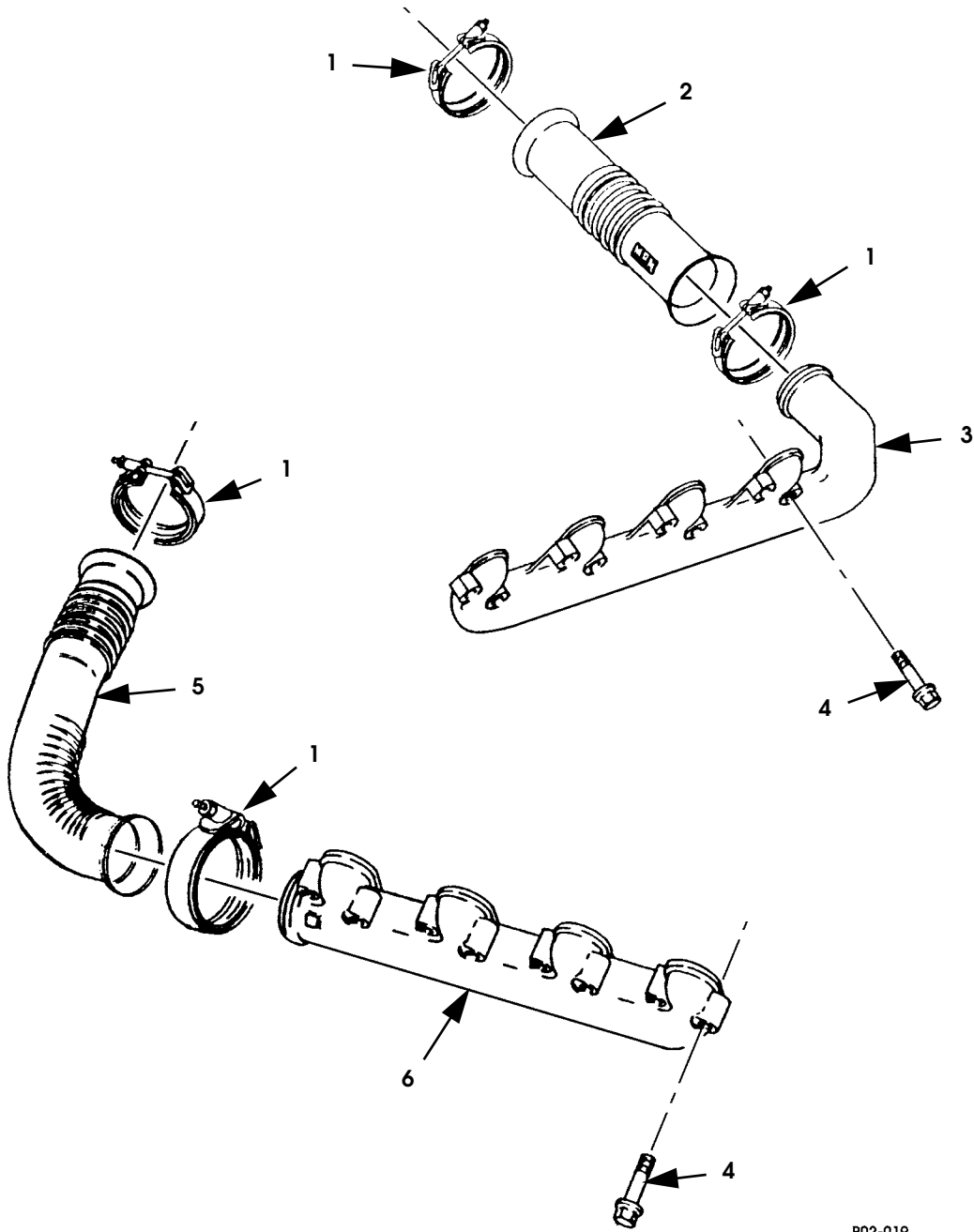

Figure 2-13. Exhaust Manifolds.

# 2001 HUMMER PARTS CATALOG

**ENGINE 2-27**

ITEM	PART NUMBER	DESCRIPTION	QTY
		<b>Figure 2-13. Exhaust Manifolds.</b>	
1	5744438	CLAMP,exhaust manifold-to-turbo .....	4
2	5744464	EXHAUST PIPE, L.H. ....	1
3	5744445	EXHAUST MANIFOLD, L.H. ....	1
4	N/S	BOLT, M10-1.5 x 65 .....	16
5	5744465	EXHAUST PIPE, R.H. ....	1
6	5744446	EXHAUST MANIFOLD, R.H. ....	1

# 2001 HUMMER PARTS CATALOG

## 2-28 ENGINE

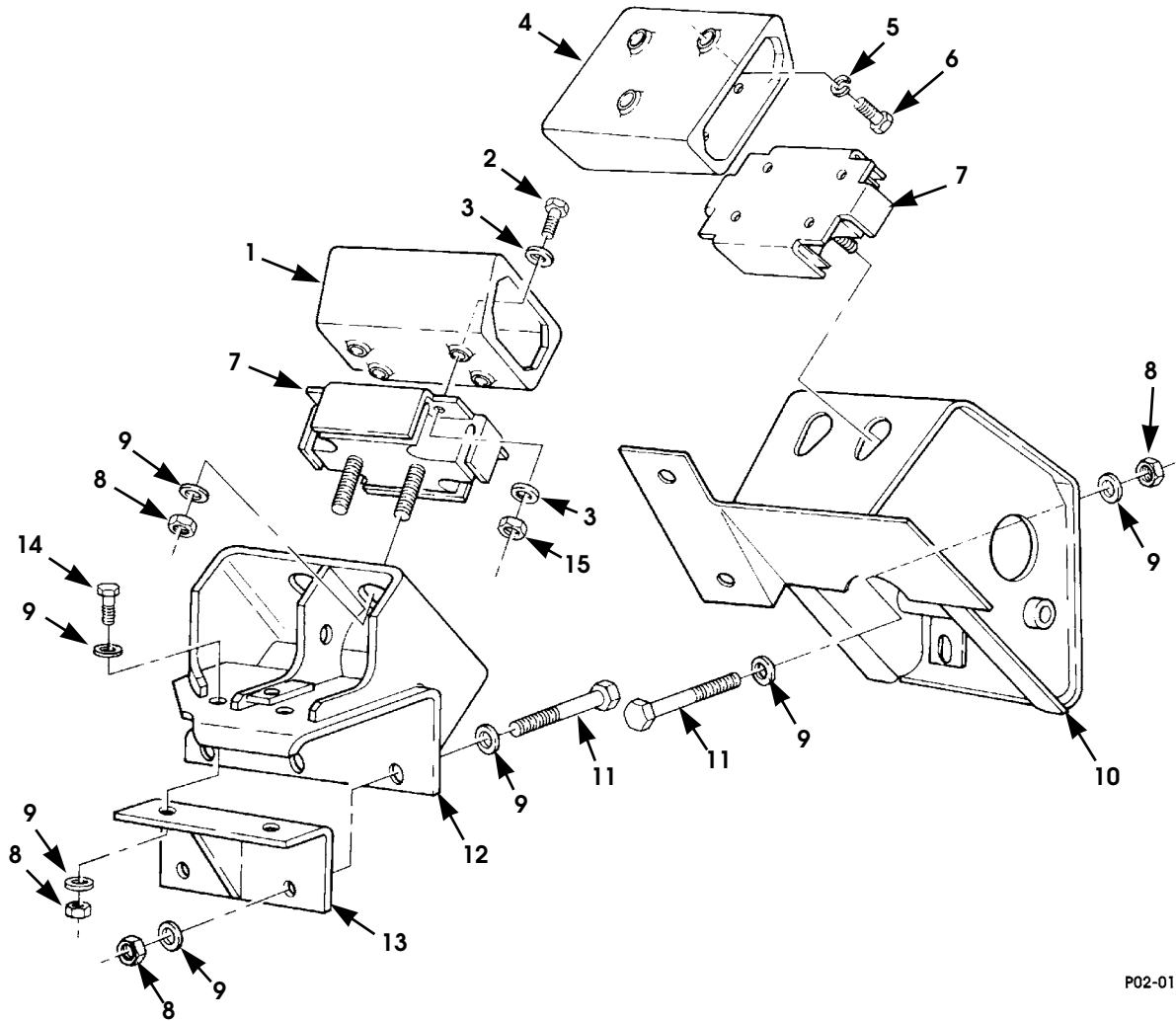

P02-012

Figure 2-14. Mounting Brackets, Engine.

# 2001 HUMMER PARTS CATALOG

## ENGINE 2-29

ITEM	PART NUMBER	DESCRIPTION	QTY
		<b>Figure 2-14. Mounting Brackets, Engine.</b>	
1	12339133	BRACKET, engine block to insulator, R.H. . . . .	1
2	N/S	SCREW, 3/8 - 16 X 1 1/4, Gr8, insulator-to-engine mount	8
3	N/S	WASHER, flat, type B, hardened, 3/8, ZN . . . . .	16
4	12339132	BRACKET, engine block to insulator, L.H. . . . .	1
5	N/S	LOCKWASHER, M10, engine mount . . . . .	6
6	N/S	SCREW, M10 - 1.5 x 25, engine mount . . . . .	6
7	12339179	MOUNT, resilient . . . . .	2
8	N/S	LOCKNUT, 1/2 - 13, Gr8, CAD, engine mount . . . . .	13
9	N/S	WASHER, flat, hardened, 1/2, type B . . . . .	22
10	12338205	BRACKET, frame to insulator . . . . .	1
11	N/S	SCREW, 1/2 - 13 x 4 1/2, Gr8, CAD, engine mount . . . . .	7
12	12338183	BRACKET, frame to insulator, R.H. . . . .	1
13	12338163	BRACKET, engine mount . . . . .	1
14	N/S	SCREW, 1/2 - 13 x 1 1/4, Gr8, CAD, . . . . . bracket-to-engine mount	2
15	N/S	LOCKNUT, 3/8 - 16, Gr8, insulator-to-engine mount . . . . .	8

# 2001 HUMMER PARTS CATALOG

## 2-30 ENGINE

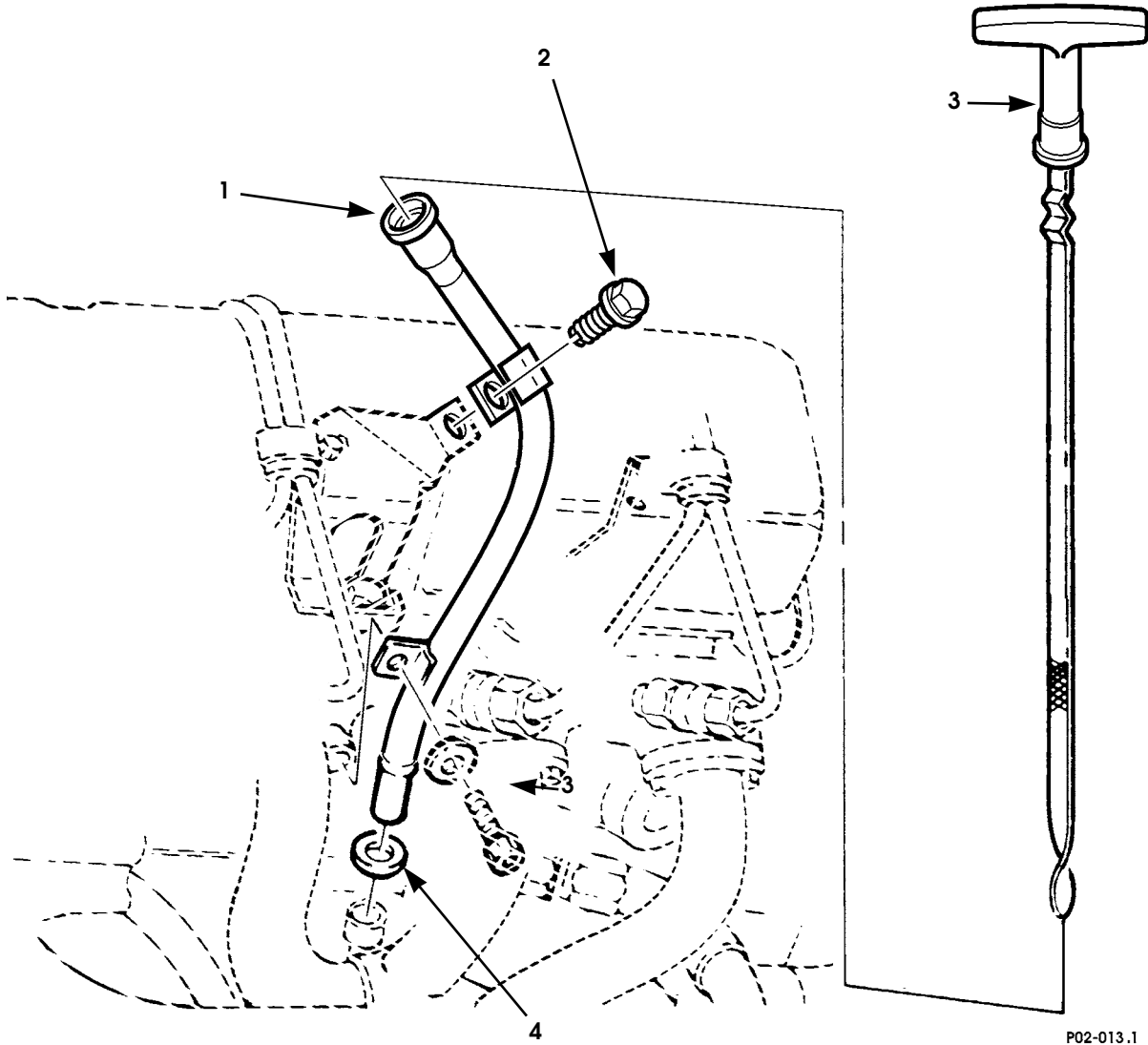

Figure 2-15. Oil Dipstick and Tube Assembly, Engine.

# 2001 HUMMER PARTS CATALOG

## ENGINE 2-31

ITEM	PART NUMBER	DESCRIPTION	QTY
		<b>Figure 2-15.</b> <b>Oil Dipstick and Tube Assembly, Engine.</b>	
1	6006825	TUBE ASSEMBLY, engine oil dipstick . . . . .	1
2	5741162	SCREW, flange head, engine oil dipstick . . . . .	1
3	6006824	DIPSTICK, engine oil level . . . . .	1
4	274244	O-RING, tube assembly, . . . . .	1



# 2001 HUMMER PARTS CATALOG

## 2-32 ENGINE

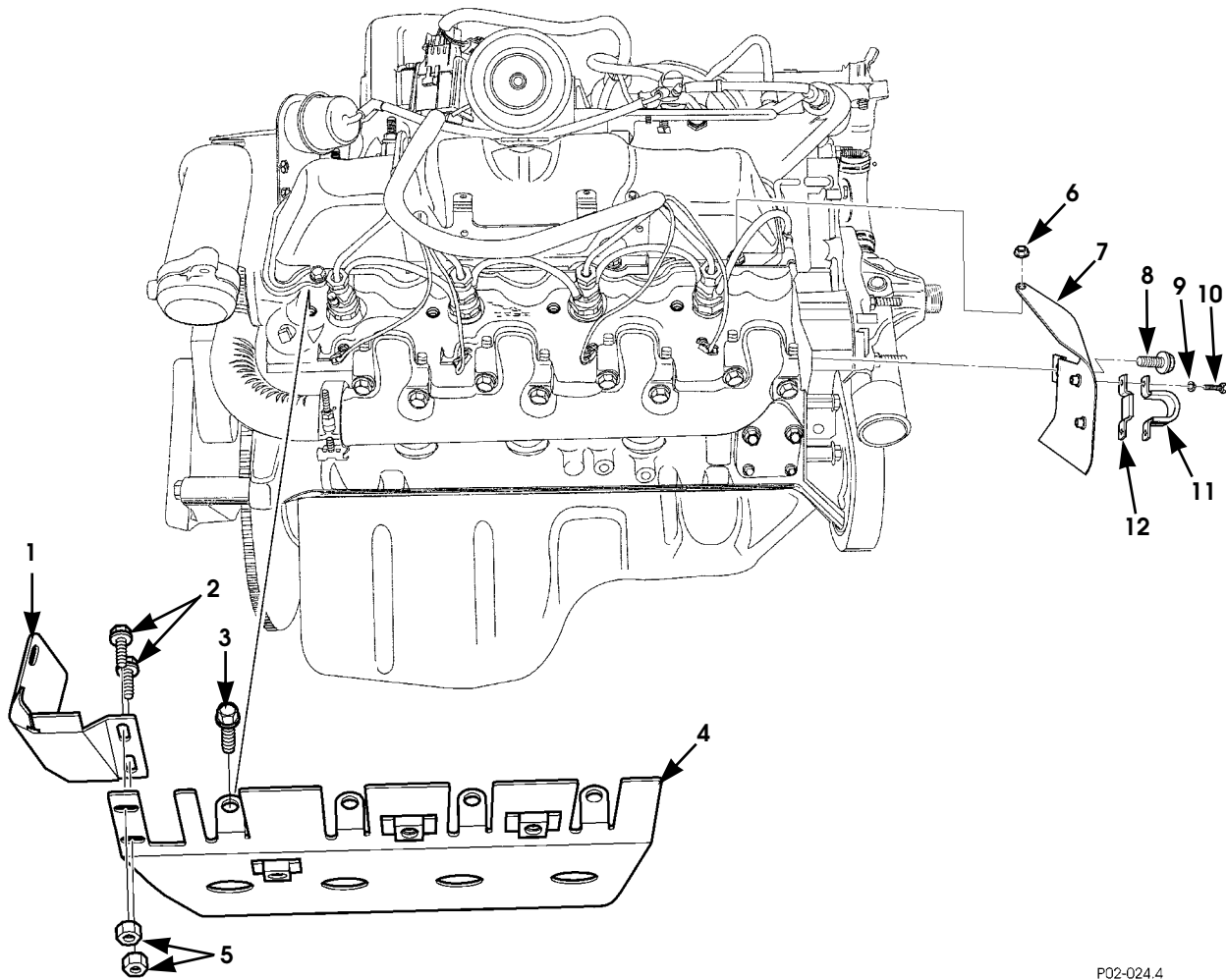

Figure 2-16. Exhaust Manifold Heat Shield.

# 2001 HUMMER PARTS CATALOG

## ENGINE 2-33

ITEM	PART NUMBER	DESCRIPTION	QTY
		<b>Figure 2-16.</b> <b>Exhaust Manifold Heat Shield.</b>	
1	RCSK17221	HEAT SHIELD, rear .....	1
2	N/S	SCREW, phcr, #10 - 24 x 3/4.....	2
3	N/S	SCREW, flanged hex head, M10 - 1.5 x 65, class 10.9. .	4
4	RCSK17282	HEAT SHIELD, R.H. ....	1
5	N/S	NUT & LOCKWASHER ASSEMBLY, #10 - 24.....	2
6	N/S	NUT, flanged, M8 - 1.25 .....	1
7	6007193	BRACKET, engine wiring harness .....	1
8	N/S	SCREW, flanged, M10 - 1.50 x 13 .....	1
9	N/S	LOCKWASHER, 1/4 .....	2
10	N/S	BOLT, 1/4 - 20 x 1, Gr5. ....	2
11	12340663-1	CLAMP, cushioned.....	1
12	N/S	CROSSBAR .....	1



# 2001 HUMMER PARTS CATALOG

## FUEL, EMISSIONS AND EXHAUST 3-1

### Section 3

#### FUEL, EMISSIONS AND EXHAUST

TITLE	PAGE NUMBER
Accelerator Pedal Assembly . . . . .	3-8
Air Cleaner, Air Horn, and Related Parts . . . . .	3-10
Exhaust Pipes and Related Parts . . . . .	3-28
Fuel Filler Pipe Assembly and Vent Lines, Main Fuel Tank . . . . .	3-20
Fuel Filler, Auxiliary Fuel Tank . . . . .	3-22
Fuel Filter Assembly and Mounting Hardware . . . . .	3-26
Fuel Injection Pump and Fuel Intake Line . . . . .	3-4
Fuel Injection Supply and Return Lines . . . . .	3-6
Fuel Pump and Mounting Hardware . . . . .	3-2
Fuel Supply and Return Lines . . . . .	3-14
Fuel Tank (Auxiliary) Assembly and Mounting Hardware . . . . .	3-18
Fuel Tank Vent Line, Filter, and Mounting Hardware . . . . .	3-24
Main Fuel Tank Assembly and Mounting Straps . . . . .	3-16

# 2001 HUMMER PARTS CATALOG

## 3-2 FUEL, EMISSIONS AND EXHAUST

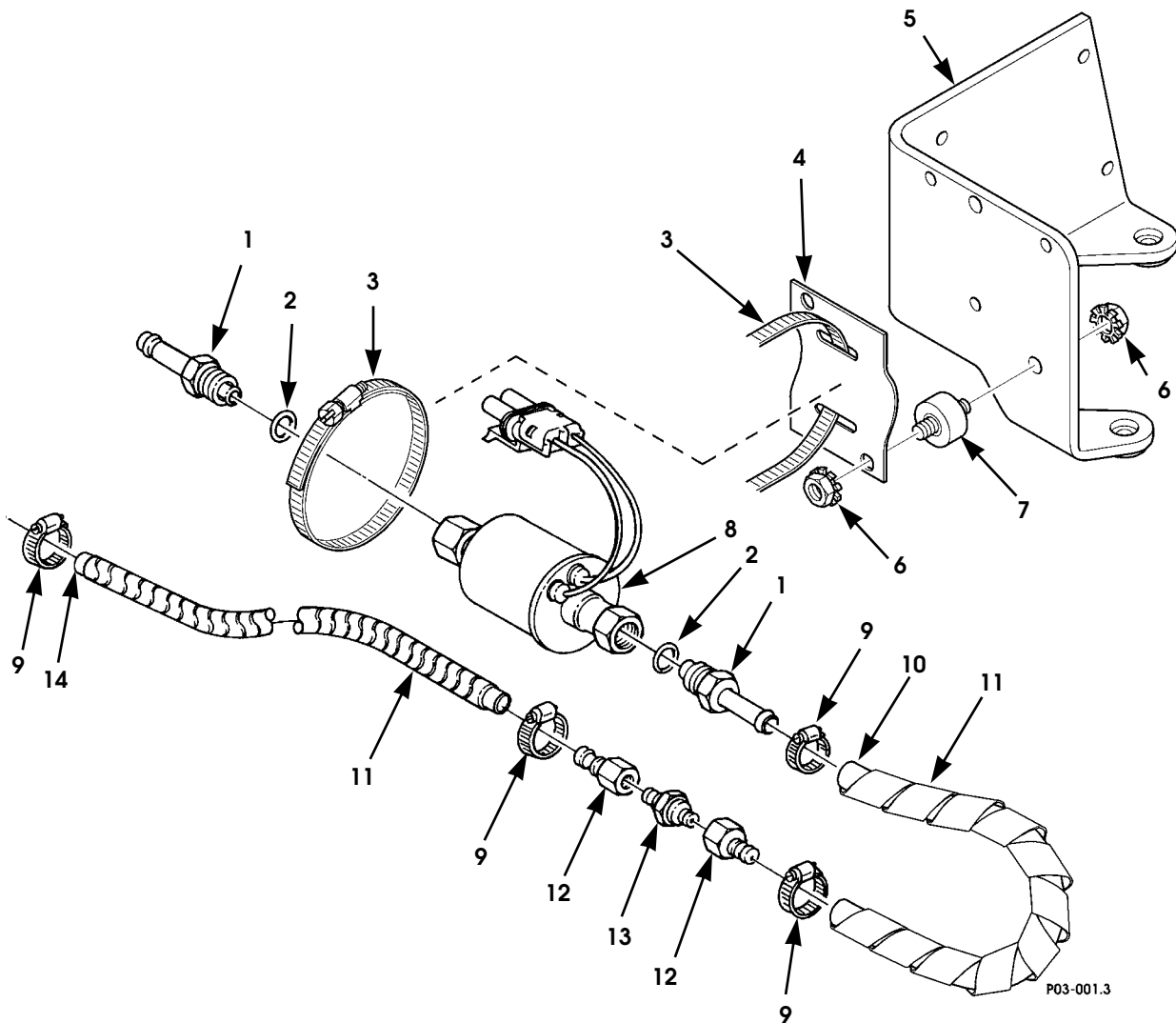

Figure 3-1. Fuel Pump and Mounting Hardware.

# 2001 HUMMER PARTS CATALOG

## FUEL, EMISSIONS AND EXHAUST 3-3

ITEM	PART NUMBER	DESCRIPTION	QTY
		<b>Figure 3-1. Fuel Pump and Mounting Hardware.</b>	
1	5939725	TUBE ASSEMBLY, fuel line adapter . . . . .	2
2	12340395	SEAL, O-ring . . . . .	2
3	N/S	CLAMP, hose, stainless, 1 5/16" - 2 1/4", fuel pump . . .	1
4	6010655B9	SADDLE BRACKET, fuel pump . . . . .	1
5	6010657B9	BRACKET ASSEMBLY, fuel filter and pump mounting . .	1
6	N/S	NUT AND LOCKWASHER ASSEMBLY, 1/4 - 20 . . . . .	2
7	5939998	ISOLATOR, fuel pump mounting bracket . . . . .	2
8	6010682	FUEL PUMP ASSEMBLY . . . . .	1
9	N/S	CLAMP, hose, stainless, 5/16", fuel hose . . . . .	4
10	N/S	HOSE, filter to pump, 12-inch, SEE NOTE 1 . . . . .	1
11	5742924	WRAP, spiral, 5-inch . . . . .	2
12	12342951-2	HOSE BARB . . . . .	2
13	12342953-2	CHECK VALVE. . . . .	1
14	6001262	HOSE, 5-inch, fuel filter inlet. . . . .	1
		NOTE 1: MAKE FROM BULK HOSE P/N 5741067 3/8" X 25' ROLL	

# 2001 HUMMER PARTS CATALOG

## 3-4 FUEL, EMISSIONS AND EXHAUST

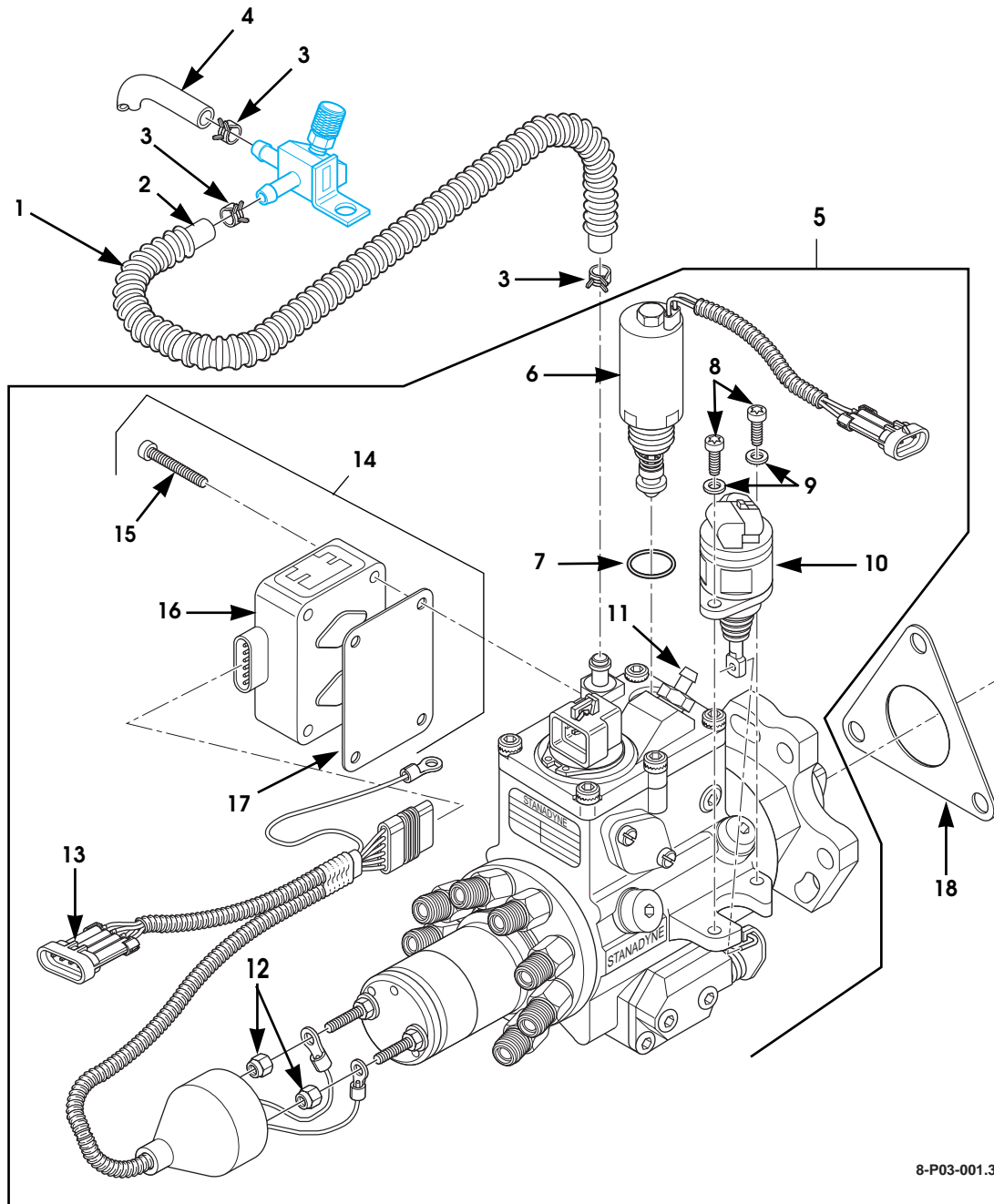

Figure 3-2. Fuel Injection Pump and Fuel Intake Line.

# 2001 HUMMER PARTS CATALOG

## FUEL, EMISSIONS AND EXHAUST 3-5

ITEM	PART NUMBER	DESCRIPTION	QTY
		<b>Figure 3-2. Fuel Injection Pump and Fuel Intake Line.</b>	
1	N/S	CONVOLUTED CONDUIT, 16 1/2" long, fuel pressure service port-to-fuel injection pump, SEE NOTE 1 . . . . .	1
2	N/S	HOSE, 1/4" x 22" long, fuel pressure service port-to-fuel injection pump, SEE NOTE 2 . . . . .	1
3	N/S	CLAMP, constant tension, 1/2", fuel line . . . . .	3
4	N/S	HOSE, 1/4" x 24" long, fuel filter-to-fuel pressure service port, SEE NOTE 2 . . . . .	1
5	5745221	PUMP, fuel injection, 6.5L . . . . .	1
5	5745171	PUMP, fuel injection, 6.5L, remanufactured . . . . .	1
6	5744937	•SOLENOID ASSEMBLY, engine shut-off (ESO) . . . . .	1
7	S.I.A.	•O-RING, ESO solenoid . . . . .	1
8	N/S	•SCREW, mounting . . . . .	2
9	N/S	•WASHER, flat . . . . .	2
10	5745012	•MOTOR ASSEMBLY, injection timing stepper (ITS) . . . . .	1
11	5745014	•PRESSURE REGULATOR ASSEMBLY . . . . .	1
12	N/S	•LOCKNUT, harness attaching . . . . .	2
13	5745013	•WIRING HARNESS . . . . .	1
14	5745016	•KIT, PMD-heat transfer pad . . . . .	1
15	S.I.K.	•SCREW, mounting . . . . .	4
16	5744959	•DRIVER, pump-mounted fuel solenoid (PMD) . . . . .	1
17	5744962	•HEAT TRANSFER PAD . . . . .	1
18	5740059	GASKET, fuel injector pump, SEE NOTE 3 . . . . .	1
		NOTE 1: CUT FROM SLIT CONVOLUTED CONDUIT 3/4" I.D. X 22" LONG, P/N 6010240	
		NOTE 2: MAKE FROM BULK HOSE P/N 5741068 1/4" X 25' ROLL	
		NOTE 3: PART OF ENGINE CYLINDER HEAD GASKET SET, P/N 5714842.	



# 2001 HUMMER PARTS CATALOG

## 3-6 FUEL, EMISSIONS AND EXHAUST

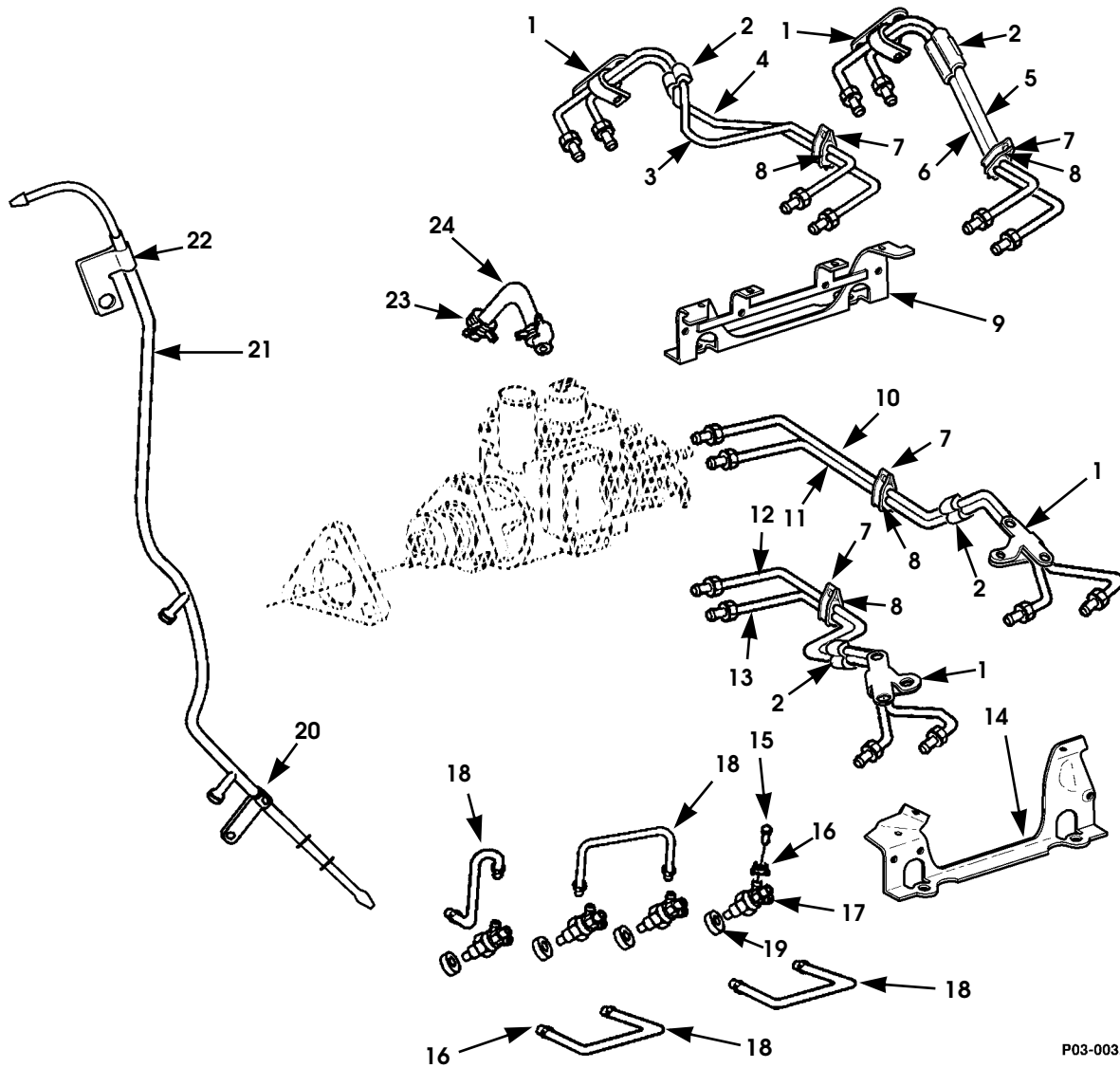

P03-003.1

Figure 3-3. Fuel Injection Supply and Return Lines.

# 2001 HUMMER PARTS CATALOG

## FUEL, EMISSIONS AND EXHAUST 3-7

ITEM	PART NUMBER	DESCRIPTION	QTY
		<b>Figure 3-3. Fuel Injection Supply and Return Lines.</b>	
1	N/S	CLAMP, fuel injection tube . . . . .	4
2	N/S	CLIP, one-piece plastic, fuel injection tube. . . . .	4
3	5744707	TUBE, pump to injector, #2 cylinder . . . . .	1
4	5744709	TUBE, pump to injector, #4 cylinder . . . . .	1
5	5744713	TUBE, pump to injector, #8 cylinder . . . . .	1
6	5744711	TUBE, pump to injector, #6 cylinder . . . . .	1
7	5740179	CLAMP, fuel injection tube . . . . .	4
8	5740537	INSERT, fuel injection tube clamp . . . . .	4
9	5742564	BRACKET, fuel injection lines, R.H. . . . .	1
10	5744712	TUBE, pump to injector, #7 cylinder . . . . .	1
11	5744710	TUBE, pump to injector, #5 cylinder . . . . .	1
12	5744708	TUBE, pump to injector, #3 cylinder . . . . .	1
13	5744706	TUBE, pump to injector, #1 cylinder . . . . .	1
14	5743288	BRACKET, fuel injection lines, L.H. . . . .	1
15	5740210	CAP, fuel injection nozzle . . . . .	2
16	5741895	CLAMP, fuel drain tube . . . . .	18
17	5743223	NOZZLE, fuel injection . . . . .	8
18	5740211	HOSE, 7-inch, fuel drain, . . . . .	8
19	5740058	GASKET, nozzle . . . . .	8
20	5740171	CLAMP, fuel drain. . . . .	2
21	5745042	TUBE ASSEMBLY, fuel drain return . . . . .	1
22	N/S	CLAMP, fuel return tube, L.H. side . . . . .	1
23	N/S	CLAMP, fuel drain return hose . . . . .	2
24	N/S	HOSE, 6-inch, fuel return, pump-to-return tube, SEE NOTE 1	1
		NOTE 1: MAKE FROM BULK HOSE P/N 5741163, 1/2" O.D. X 1/4" I.D. X 25' ROLL	

# 2001 HUMMER PARTS CATALOG

## 3-8 FUEL, EMISSIONS AND EXHAUST

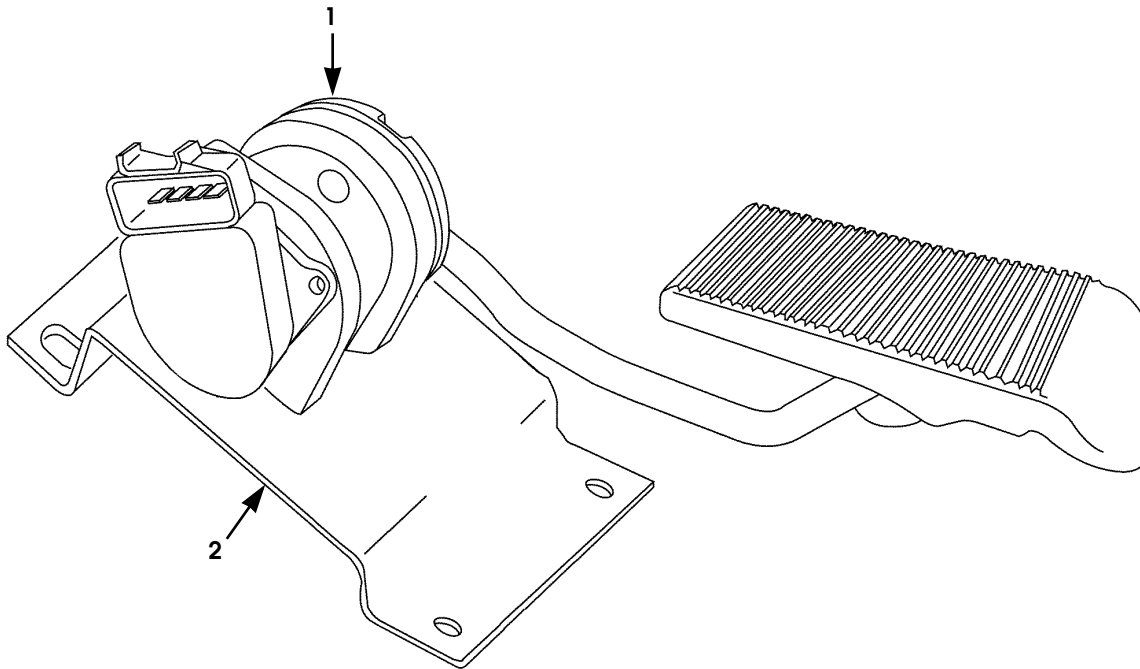

P03-026 .2

*Figure 3-4. Accelerator Pedal Assembly.*

# 2001 HUMMER PARTS CATALOG

## FUEL, EMISSIONS AND EXHAUST 3-9

ITEM	PART NUMBER	DESCRIPTION	QTY
		<b>Figure 3-4. Accelerator Pedal Assembly.</b>	
1	6007221	ACCELERATOR PEDAL ASSEMBLY .....	1
2	6007177	•BRACKET, accelerator mounting .....	1

# 2001 HUMMER PARTS CATALOG

## 3-10 FUEL, EMISSIONS AND EXHAUST

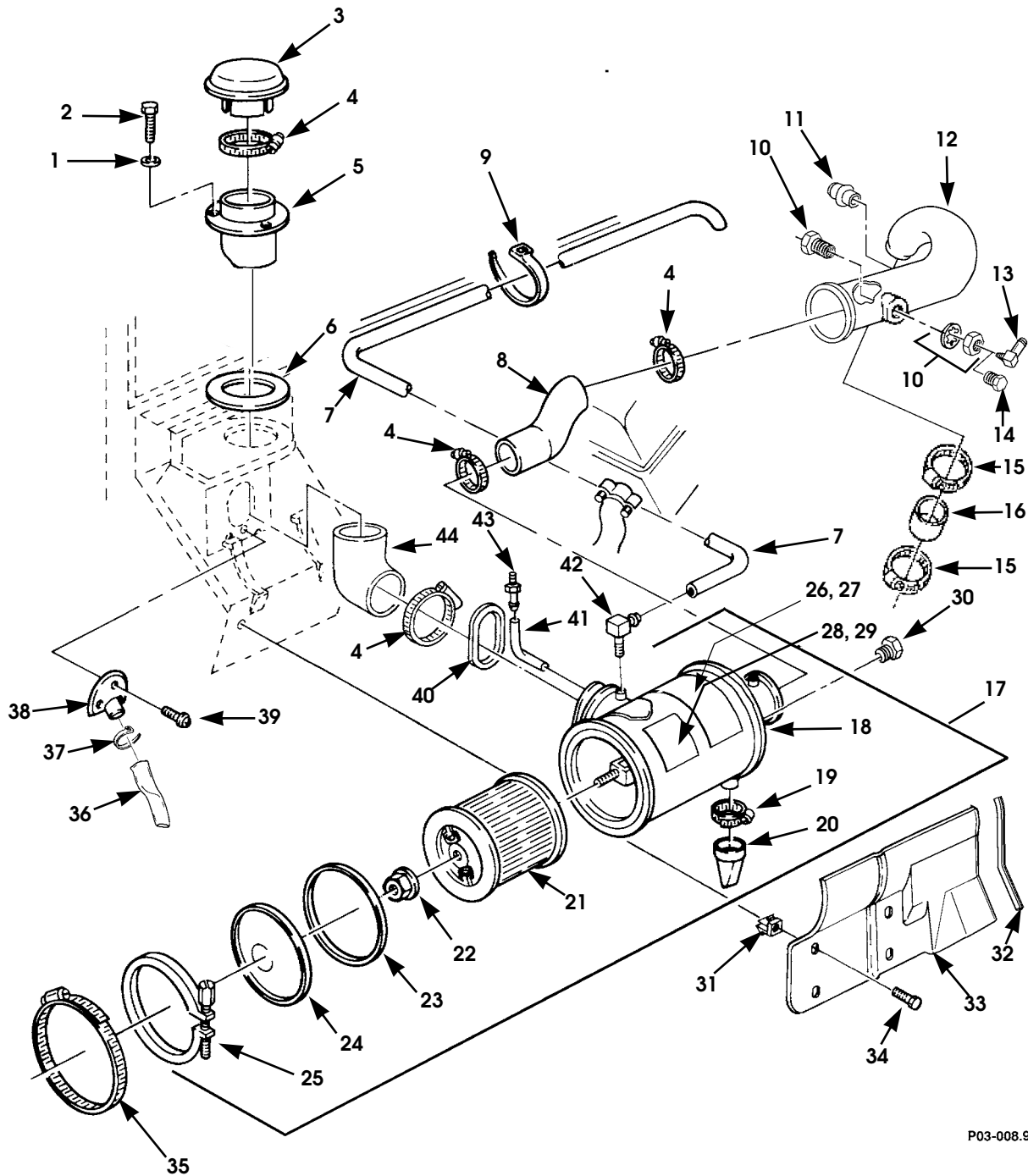

P03-008.9

Figure 3-5. Air Cleaner, Air Horn, and Related Parts.

# 2001 HUMMER PARTS CATALOG

## FUEL, EMISSIONS AND EXHAUST 3-11

ITEM	PART NUMBER	DESCRIPTION	QTY
		<b>Figure 3-5. Air Cleaner, Air Horn, and Related Parts.</b>	
1	N/S	WASHER, flat, 1/4, CAD, air intake shield . . . . .	3
2	N/S	SCREW, 1/4 - 20 x 7/16, Gr8, ZN, air intake shield. . . . .	3
3	12338377P	CAP, air intake . . . . .	1
4	N/S	CLAMP, 5.0" - 2.0", air intake . . . . .	4
5	6001738P	ADAPTER, air intake . . . . .	1
6	6009745	GASKET, air intake housing . . . . .	1
7	N/S	TUBE, 28-inch, air cleaner vent line, SEE NOTE 1 . . . . .	1
8	12338381	HOSE, induction . . . . .	1
9	N/S	TIE WRAP, tube air cleaner . . . . .	1
10	12339984	COUPLING ASSEMBLY, bulkhead . . . . .	1
11	RCSK17735	CDR VALVE AND TUBE ASSEMBLY . . . . .	1
12	6007701	AIR HORN INDUCTION SYSTEM . . . . .	1
13	12339415	ELBOW, 90 deg, to hose, barbed (with CTIS only) . . . . .	1
14	N/S	PLUG, pipe, hex head, 1/4" NPT (w/o CTIS only). . . . .	1
15	N/S	CLAMP, hose, 1" - 1 1/4" . . . . .	2
16	RCSK17700	HOSE, turbo intake, . . . . .	1
17	WA12339911	AIR CLEANER ASSEMBLY . . . . .	1
18	S.I.A.	•BODY, air cleaner . . . . .	1
19	N/S	•CLAMP dust unloader. . . . .	1
20	12342873	•UNLOADER, dust . . . . .	1
21	12342870	•FILTER ELEMENT, air cleaner . . . . .	1
22	12342871	•NUT/LOCKWASHER, air cleaner . . . . .	1
23	12342872	•GASKET, air filter . . . . .	1
24	12342869	•COVER, air cleaner . . . . .	1
25	12342874	•CLAMP air cleaner . . . . .	1
26	6011761	LABEL, emission control . . . . .	1
27	6010397	DECAL, clear protective film, 8" x 2 1/4" . . . . .	1
28	6011760	LABEL, CARB MDV . . . . .	1
29	6001684	DECAL, clear protective film, 4 7/8" x 2 7/8" . . . . .	1
30	N/S	PLUG, 1/8 brass, hex, air cleaner . . . . .	1
31	12340922	GROMMET, air cleaner shield. . . . .	4
32	6009588	EDGE GUARD, air cleaner shield . . . . .	1
33	6009455	SHIELD, air cleaner. . . . .	1
34	N/S	SCREW, tapping, #10 - 16 x 1/2, ZN, air cleaner shield	4
35	N/S	CLAMP, 2.25" - 2.00", air cleaner . . . . .	3
36	6009746	DRAIN HOSE . . . . .	1
37	N/S	TIE WRAP . . . . .	1
38	12338842	BRACKET, air intake drainage tube . . . . .	1
39	N/S	SCREW, tapping, phcr, #8 - 18 x 3/8, drainage bracket .	3

# 2001 HUMMER PARTS CATALOG

## 3-12 FUEL, EMISSIONS AND EXHAUST

ITEM	PART NUMBER	DESCRIPTION	QTY
		<b>Figure 3-5.</b> <b>Air Cleaner, Air Horn, and Related Parts.</b>	
40	6005110	GASKET, air cleaner intake . . . . .	1
41	12340799	TUBE, vent line. . . . .	1
42	N/S	ELBOW, 3/8 NPT to 1/4, pipe to hose, vent line . . . . .	1
43	12339978	CONNECTOR, vent line . . . . .	1
44	6001737	ELBOW, air cleaner. . . . .	1
		NOTE 1: MAKE FROM BULK NYLON TUBE P/N 5741079, 3/16" X 250' ROLL	





# 2001 HUMMER PARTS CATALOG

## 3-14 FUEL, EMISSIONS AND EXHAUST

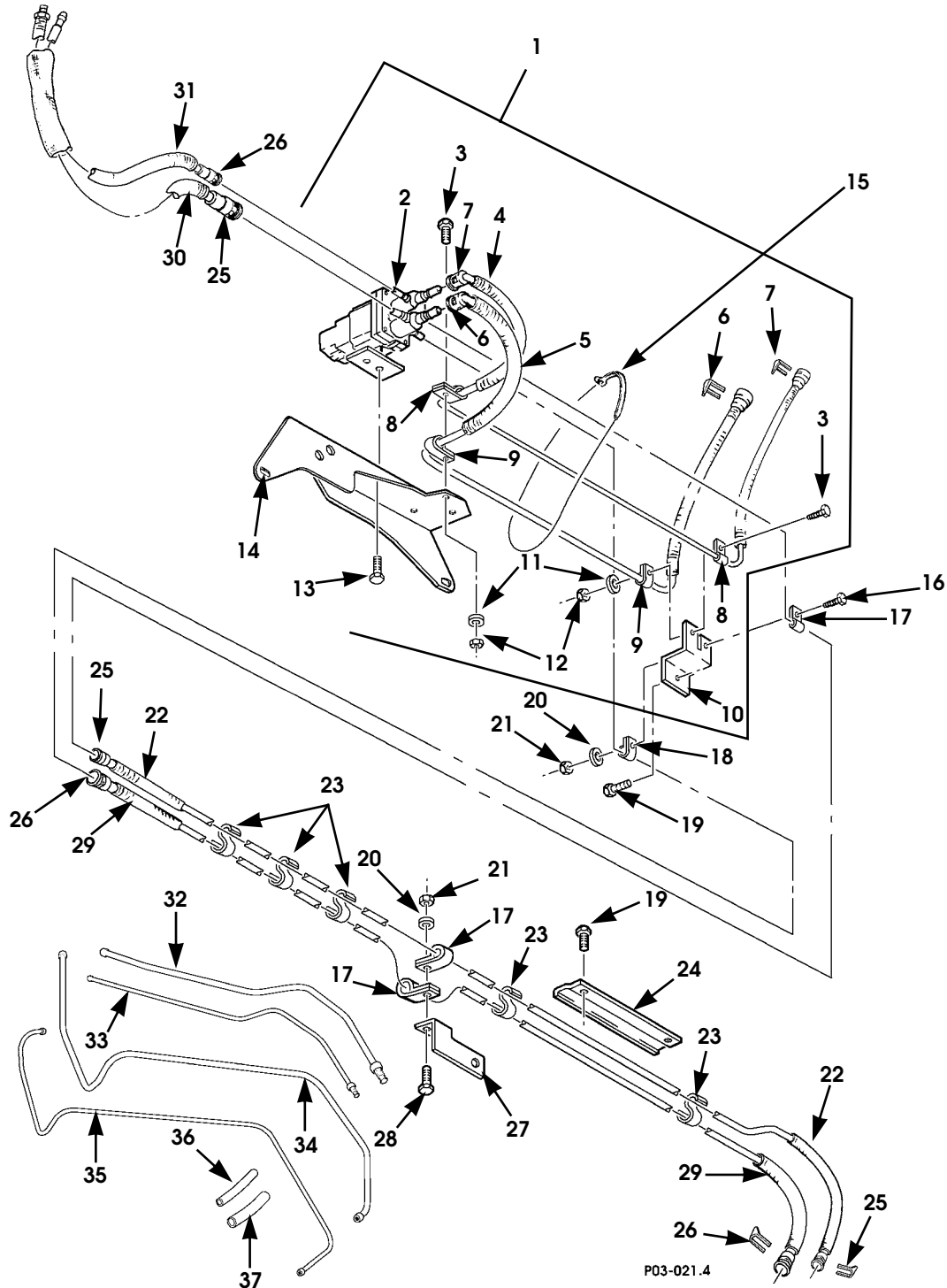

Figure 3-6. Fuel Supply and Return Lines.

# 2001 HUMMER PARTS CATALOG

## FUEL, EMISSIONS AND EXHAUST 3-15

ITEM	PART NUMBER	DESCRIPTION	QTY
		<b>Figure 3-6. Fuel Supply and Return Lines.</b>	
1	6007417	FUEL BUNDLE ASSEMBLY . . . . .	1
1	6007063	FUEL BUNDLE ASSEMBLY, for fleet use with single tank . .	1
2	6005966	• VALVE ASSEMBLY, fuel tank selector, SEE NOTE 1. . . . .	1
2	6007083	• TUBE AND BRACKET ASSEMBLY, SEE NOTE 2 . . . . .	1
3	S.I.A.	• BOLT, 1/4 - 20 x 3/4, Gr5, CAD . . . . .	2
4	S.I.A.	• FUEL RETURN LINE. . . . .	1
5	S.I.A.	• FUEL SUPPLY LINE . . . . .	1
6	S.I.A.	• CLIP, fuel line connector, 3/8" . . . . .	2
7	S.I.A.	• CLIP, fuel line connector, 5/16" . . . . .	2
8	S.I.A.	• P-CLIP, 5/16", SEE NOTE 1 . . . . .	2
8	S.I.A.	• P-CLIP, 5/16", SEE NOTE 2 . . . . .	3
9	S.I.A.	• P-CLIP, 3/8" . . . . .	2
10	S.I.A.	• BRACKET, tube mounting, fuel bundle . . . . .	1
11	S.I.A.	• WASHER, flat, hard, 1/4, type B, ZN . . . . .	2
12	S.I.A.	• LOCKNUT, 1/4 - 20, Gr8 . . . . .	2
13	S.I.A.	• BOLT, 5/16 - 18 x 3/4, Gr8, CAD . . . . .	2
14	S.I.A.	• BRACKET, valve mounting . . . . .	1
15	N/S	TIE WRAP . . . . .	2
16	N/S	BOLT, 1/4 - 20 x 3/4, Gr5, CAD . . . . .	1
17	N/S	P-CLIP, 3/8" . . . . .	2
18	N/S	P-CLIP, 5/16" . . . . .	2
19	N/S	SCREW, tapping, #10 - 32 x 5/8. . . . .	2
20	N/S	WASHER, flat, hard, 1/4, type B, ZN . . . . .	1
21	N/S	LOCKNUT, 1/4 - 20, Gr8 . . . . .	1
22	6006763	TUBE ASSEMBLY, return, valve-to-auxiliary tank . . . . .	1
23	N/S	S-CLIP . . . . .	5
24	6006793	BRACKET, hold down, auxiliary fuel lines . . . . .	1
25	N/S	CLIP, fuel line connector, 5/16" . . . . .	3
26	N/S	CLIP, fuel line connector, 3/8" . . . . .	3
27	6007724B9	BRACKET, auxiliary fuel line tubes . . . . .	1
28	N/S	• BOLT, 1/4 - 20 x 3/4, Gr5, CAD . . . . .	1
29	6006762	TUBE ASSEMBLY, supply, auxiliary tank-to-valve . . . . .	1
30	6006841	FUEL SUPPLY LINE ASSEMBLY . . . . .	1
31	6006896	FUEL RETURN LINE ASSEMBLY, . . . . .	1
32	5939876	TUBE, fuel supply. . . . .	1
33	5939877	TUBE, fuel return . . . . .	1
34	12342949	TUBE ASSEMBLY, fuel supply . . . . .	1
35	12342950	TUBE ASSEMBLY, fuel return . . . . .	1
36	12338560-3	HOSE, fuel return . . . . .	1
37	12338561-2	HOSE, fuel supply . . . . .	1
		NOTE 1: FOR STANDARD VEHICLES WITH TWO TANKS. NOTE 2: FOR FLEET VEHICLES WITH SINGLE FUEL TANK.	

# 2001 HUMMER PARTS CATALOG

## 3-16 FUEL, EMISSIONS AND EXHAUST

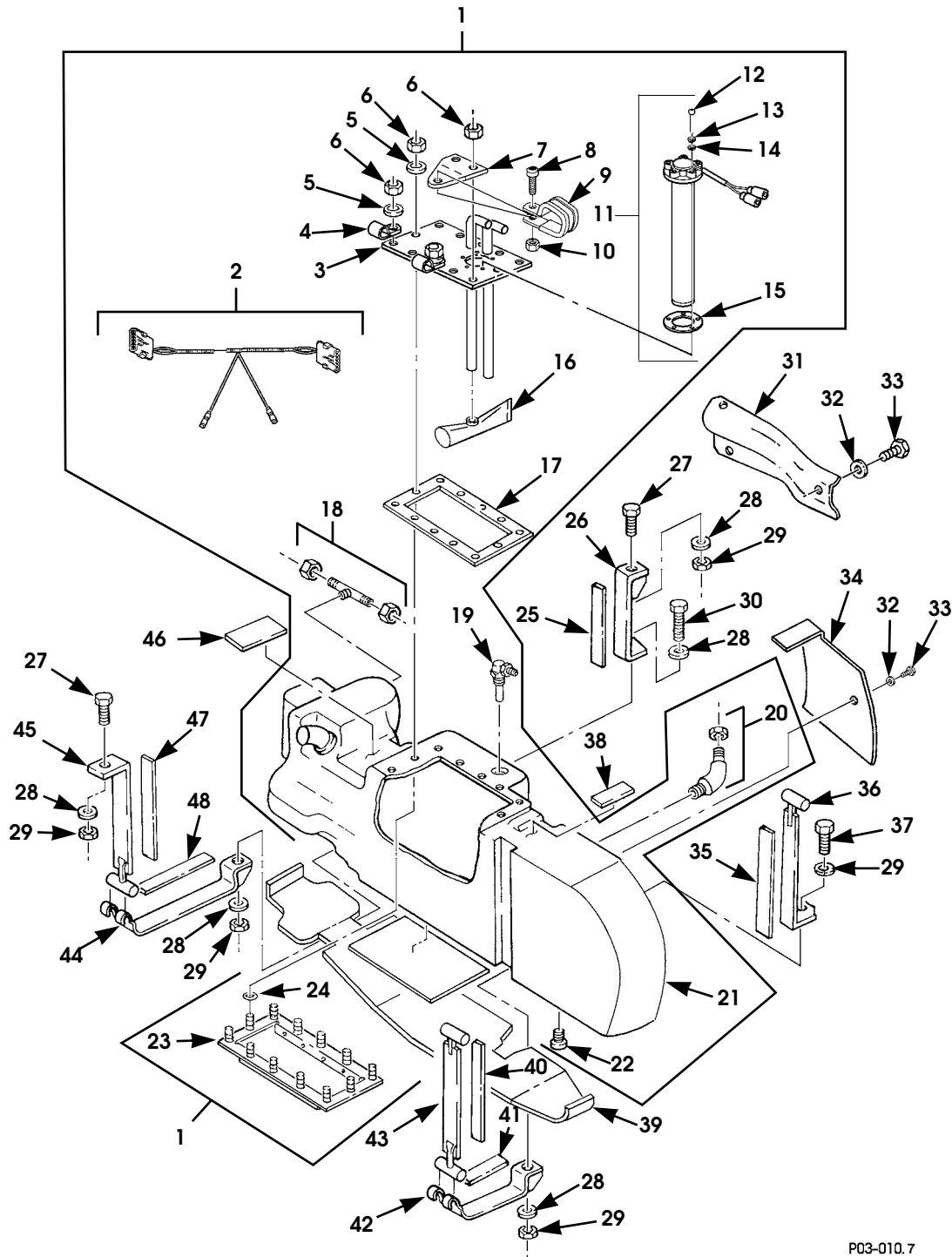

P03-010.7

Figure 3-7. Main Fuel Tank Assembly and Mounting Straps.

# 2001 HUMMER PARTS CATALOG

## FUEL, EMISSIONS AND EXHAUST 3-17

ITEM	PART NUMBER	DESCRIPTION	QTY
		<b>Figure 3-7.</b> <b>Main Fuel Tank Assembly and Mounting Straps.</b>	
1	6010075	FUEL TANK ASSEMBLY, for vehicles w/aux tank, SEE NOTE 1	1
2	6005568	•JUMPER ASSEMBLY, tank for vehicles w/o aux tank . . .	1
2	6005569	•JUMPER ASSEMBLY, main tank w/aux tank . . . . .	1
3	6006979	•PLATE, fuel tank access . . . . .	1
4	S.I.A.	•CLAMP, cushioned, 9/16, harness . . . . .	2
5	S.I.A.	•WASHER, flat, hard, 1/4, ZN, fuel tank access plate . .	10
6	S.I.A.	•LOCKNUT, 1/4 - 20, Gr8, fuel tank access plate . . . .	12
7	6006737	•BRACKET, fuel line support . . . . .	1
8	N/S	•SCREW, #10 - 32 x 5/8 . . . . .	1
9	MS2133-82	•P-CLAMP, cushioned . . . . .	1
10	N/S	•LOCKNUT, pt, #10 - 32 . . . . .	1
11	6009942	•TRANSMITTER, engine fuel level . . . . .	1
12	S.I.A.	•SCREW, #10 - 24 x 1.25, CAD, fuel level transmitter . .	5
13	S.I.A.	•LOCKWASHER, #10, med, ZN, fuel level transmitter. . .	5
14	S.I.A.	•WASHER, flat, #10, fuel level transmitter . . . . .	5
15	5745031	•GASKET, fuel level transmitter . . . . .	1
16	12338556	•FUEL STRAINER, fuel supply tube . . . . .	1
17	6004924	•GASKET, fuel tank access plate . . . . .	1
18	8-6-100425BA	•TEE, pipe to tube . . . . .	1
19	6001342	•VALVE, rollover . . . . .	1
20	8-6-100302BA	•ELBOW, pipe to tube . . . . .	1
21	12460105	•FUEL TANK . . . . .	1
22	12340000	•DRAINPLUG, fuel . . . . .	1
23	12460140	•RETAINER, access plate . . . . .	1
24	12342933	•O-RING, fuel tank access . . . . .	12
25	12460108-3	INSULATOR STRAP, inner, rear . . . . .	1
26	12338568	STRAP, fuel tank, inner rear . . . . .	1
27	N/S	SCREW, 3/8 - 16 x 1, Gr8, CAD, fuel tank strap . . . . .	2
28	N/S	WASHER, flat, 3/8, type B, fuel tank strap . . . . .	6
29	N/S	NUT, 3/8 - 16, Gr8, CAD, fuel tank strap . . . . .	4
30	N/S	BOLT, 3/8 - 16 x 2 1/4, Gr8, CAD. . . . .	1
31	12460143	SHIELD . . . . .	1
32	12341718	FLATWASHER . . . . .	4
33	N/S	SCREW, sl hd, 1/4 - 28 x 5/8, ZN . . . . .	4
34	12460102	SHIELD, fuel tank . . . . .	1
35	12338557-2	ANTI-SQUEAK, fuel tank, front . . . . .	1
36	12460103	STRAP, fuel tank, inner front . . . . .	1
37	N/S	BOLT, 3/8 - 16 x 2, Gr8, CAD . . . . .	1
38	12460108-3	INSULATOR STRAP, inner, front . . . . .	1
39	6006150B9	SHIELD, fuel tank . . . . .	1
40	12460108-3	INSULATOR STRAP, outer, front . . . . .	1
41	12460108-3	INSULATOR STRAP, bottom, front . . . . .	1
42	12338571	STRAP, fuel tank, bottom front . . . . .	1
43	WA12338573	STRAP, fuel tank, outer front . . . . .	1
44	12338574	STRAP, fuel tank, bottom rear . . . . .	1
45	6007695	STRAP, fuel tank, outer rear . . . . .	1
46	12338557-1	ANTI-SQUEAK, fuel tank, rear . . . . .	1
47	12460108-3	INSULATOR STRAP, outer, rear . . . . .	1
48	12460108-3	INSULATOR STRAP, bottom, rear . . . . .	1
		NOTE 1: FOR VEHICLES W/O AUX TANK, ORDER THIS ASSEMBLY AND JUMPER ASSY. P/N 6005568.	

# 2001 HUMMER PARTS CATALOG

## 3-18 FUEL, EMISSIONS AND EXHAUST

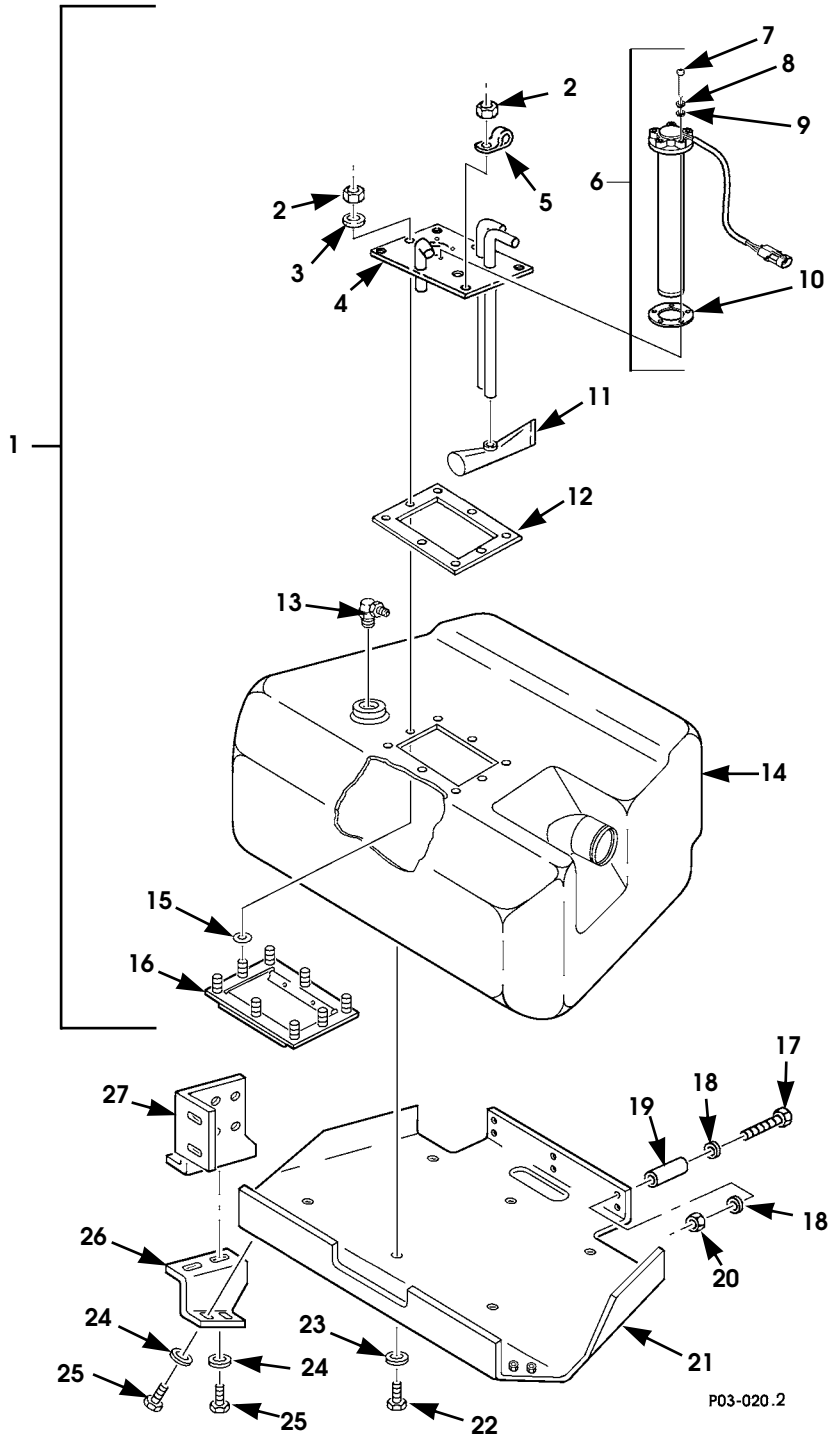

Figure 3-8. Fuel Tank (Auxiliary) Assembly and Mounting Hardware.

# 2001 HUMMER PARTS CATALOG

## FUEL, EMISSIONS AND EXHAUST 3-19

ITEM	PART NUMBER	DESCRIPTION	QTY
		<b>Figure 3-8. Fuel Tank (Auxiliary) Assembly and Mounting Hardware.</b>	
1	6010076	FUEL TANK ASSEMBLY, . . . . .	1
2	N/S	• LOCKNUT, 1/4 - 20, Gr8 . . . . .	8
3	N/S	• WASHER, flat, hardened, 1/4, ZN. . . . .	8
4	6008193	• PLATE, fuel tank access . . . . .	1
5	N/S	• CLAMP, cushioned, 3/8" . . . . .	1
6	6009943	• TRANSMITTER, engine fuel level . . . . .	1
7	S.I.A.	• • SCREW, #10 - 24 x 1.25, CAD, fuel level transmitter. . . . .	5
8	S.I.A.	• • LOCKWASHER, med, #10, ZN, fuel level transmitter . . . . .	5
9	S.I.A.	• • WASHER, flat, #10, fuel level transmitter. . . . .	5
10	5745031	• • GASKET, fuel level transmitter . . . . .	1
11	12338556	• FUEL STRAINER . . . . .	1
12	6006704	• GASKET, tank access . . . . .	1
13	6001342	• VALVE, rollover . . . . .	1
14	6006648	• FUEL TANK, auxiliary . . . . .	1
15	12342933	• O-RING, fuel tank access . . . . .	8
16	6006698	• RETAINER, access plate . . . . .	1
17	N/S	BOLT, 5/16 - 18 x 2 3/4, Gr8, CAD . . . . .	6
18	N/S	WASHER, flat, hardened, 5/16, ZN. . . . .	12
19	5594342	SPACER . . . . .	6
20	N/S	LOCKNUT, 5/16 - 18, Gr8. . . . .	6
21	6006687	SKID PLATE ASSEMBLY . . . . .	1
22	N/S	BOLT, 1/4 - 28 x 5/8, CAD . . . . .	6
23	N/S	WASHER, flat, hardened, 1/4, ZN. . . . .	6
24	N/S	WASHER, flat, 3/8, type B . . . . .	8
25	N/S	BOLT 3/8 - 16 x 1, Gr8, CAD . . . . .	8
26	6006797B9	BRACKET, skid plate mounting, R.H. . . . .	1
26	6006798B9	BRACKET, skid plate mounting, L.H. . . . .	1
27	6006741B5	BRACKET, rear bumper, L.H. . . . .	1
27	6006749B5	BRACKET, rear bumper, R.H. . . . .	1

# 2001 HUMMER PARTS CATALOG

## 3-20 FUEL, EMISSIONS AND EXHAUST

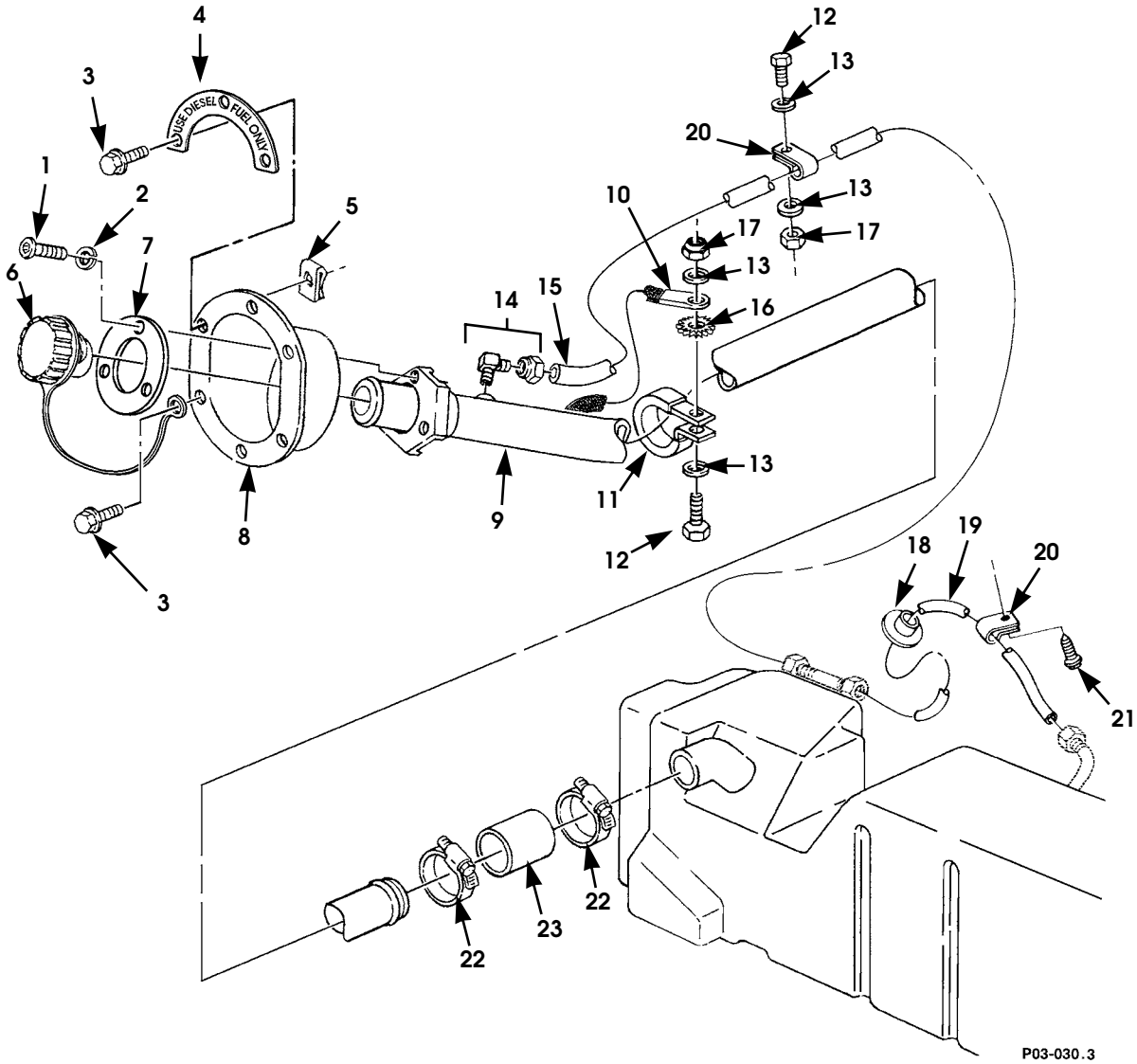

Figure 3-9. Fuel Filler Pipe Assembly and Vent Lines, Main Fuel Tank.

# 2001 HUMMER PARTS CATALOG

## FUEL, EMISSIONS AND EXHAUST 3-21

ITEM	PART NUMBER	DESCRIPTION	QTY
		<b>Figure 3-9.</b> <b>Fuel Filler Pipe Assembly and Vent Lines, Main Fuel Tank.</b>	
1	N/S	SCREW, socket head cap, 1/4 - 20 x 7/8, CAD . . . . .	3
2	N/S	LOCKWASHER, med, 1/4, ZN . . . . .	3
3	N/S	SCREW, tapping, flanged, #10 - 12 x 1, CAD . . . . .	6
4	6007666	INSTRUCTION PLATE, fuel filler . . . . .	1
4	6002652	INSTRUCTION PLATE, fuel filler, Canada . . . . .	1
4	6002651	INSTRUCTION PLATE, fuel filler, GCC . . . . .	1
5	12339426	SPEEDNUT . . . . .	6
6	6009796	CAP ASSEMBLY, fuel filler w/tether . . . . .	1
7	6008148	REINFORCEMENT RING, main tank fuel filler. . . . .	1
8	6008147	HOUSING, fuel filler opening. . . . .	1
9	6008088	FILLER NECK, fuel, main tank. . . . .	1
10	6005924	•STRAP, ground. . . . .	1
11	N/S	CLAMP, hose, dipped, 2" . . . . .	1
12	N/S	SCREW, 1/4 - 20 x 3/4, Gr5, CAD . . . . .	2
13	N/S	WASHER, flat, 1/4", hardened, ZN . . . . .	4
14	86-100202BA	ELBOW, pipe to tube, fuel tank vent tube. . . . .	1
15	N/S	TUBE, 44-inch, fuel tank vent, SEE NOTE 1 . . . . .	1
16	N/S	LOCKWASHER, toothed, 1/4, ZN . . . . .	1
17	N/S	LOCKNUT, 1/4 - 20, Gr8 . . . . .	2
18	12339892	BUSHING, fuel tank vent line. . . . .	1
19	N/S	TUBE, 27-inch, fuel tank vent, SEE NOTE 1 . . . . .	1
20	N/S	CLAMP, filler pipe vent line 1/2" cushioned. . . . .	2
21	N/S	SCREW, tapping, 1/4 - 14 x 1/2, ZN, fuel tank vent tube clamp . . . . .	1
22	N/S	CLAMP, 2.75" - 1.81", fuel filler hose. . . . .	2
23	12338551-2	HOSE, fuel filler neck to tank. . . . .	1
		NOTE 1: MAKE FROM BULK TUBING P/N CPR104420-3	



# 2001 HUMMER PARTS CATALOG

## 3-22 FUEL, EMISSIONS AND EXHAUST

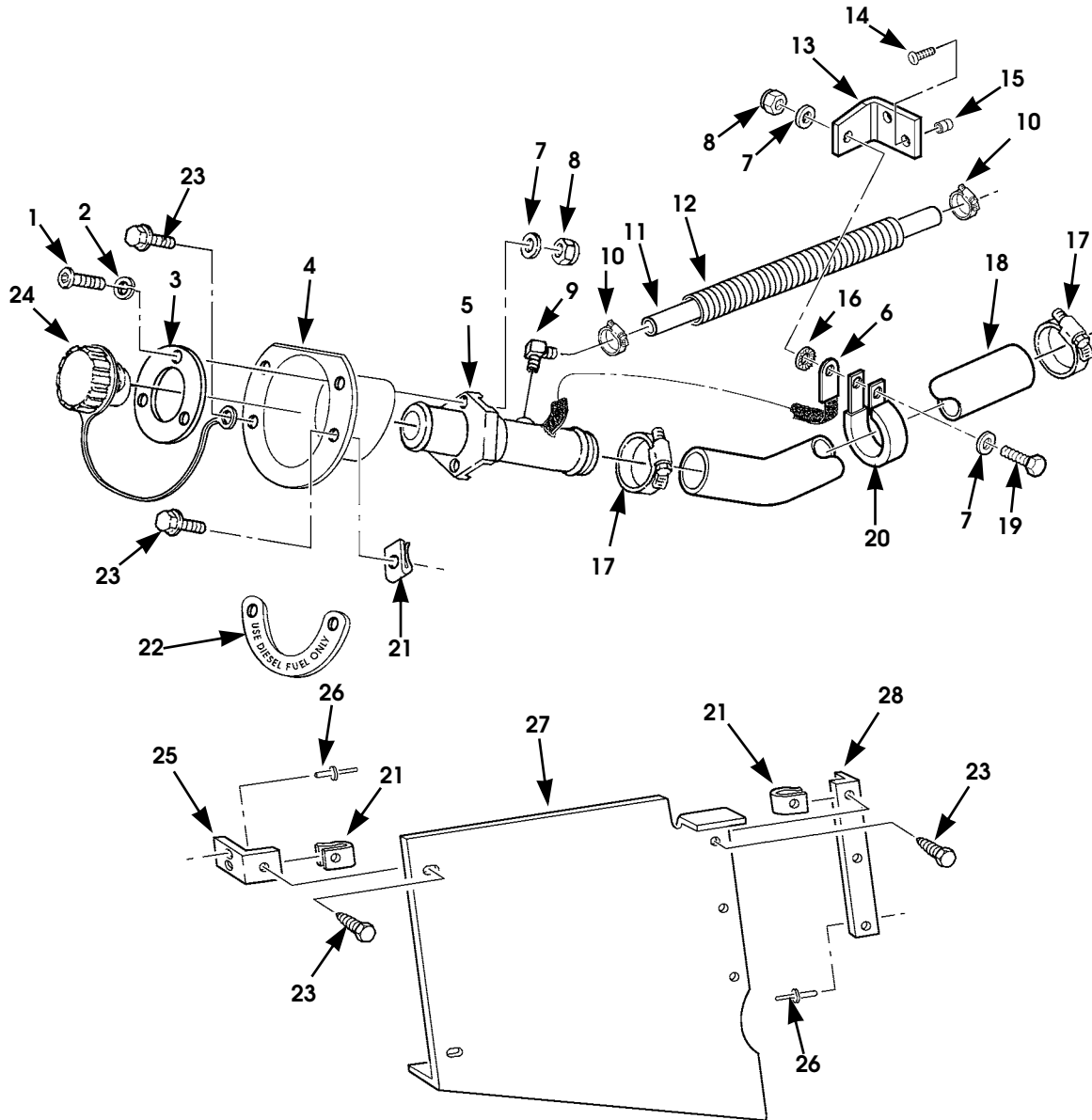

P03-031.6

Figure 3-10. Fuel Filler, Auxiliary Fuel Tank.

# 2001 HUMMER PARTS CATALOG

## FUEL, EMISSIONS AND EXHAUST 3-23

ITEM	PART NUMBER	DESCRIPTION	QTY
		<b>Figure 3-10. Fuel Filler, Auxiliary Fuel Tank.</b>	
1	N/S	SCREW, socket head cap, 1/4 - 20 x 3/4, Gr8, CAD . . .	3
2	N/S	LOCKWASHER, 1/4, ZN . . . . .	3
3	6008105	REINFORCEMENT RING, fuel filler . . . . .	1
4	6008104	HOUSING, auxiliary fuel filler . . . . .	1
5	6008163	TUBE ASSEMBLY, auxiliary fuel filler . . . . .	1
6	N/S	STRAP, ground. . . . .	1
7	N/S	WASHER, flat, hardened, 1/4, ZN . . . . .	5
8	N/S	LOCKNUT, 1/4 - 20, Gr8, CAD . . . . .	4
9	N/S	ELBOW, 90 degree, barbed, 3/8" . . . . .	2
10	N/S	CLAMP, hose, 1/2 - 1-1/4. . . . .	2
11	6008245	HOSE, vent, aux tank-to-filler neck. . . . .	1
12	6008246	CONDUIT, vent hose, aux tank . . . . .	1
13	6006670B9	BRACKET, fuel filler hanger . . . . .	1
14	N/S	LOCKBOLT, 1/4" . . . . .	2
15	NAS1080R08	COLLAR . . . . .	2
16	N/S	LOCKWASHER, external tooth, 1/4, ZN . . . . .	1
17	N/S	CLAMP, hose, 1.81" - 2.75" . . . . .	2
18	6008342	HOSE, filler neck-to-fuel tank . . . . .	1
19	N/S	BOLT, 1/4 - 20 x 3/4, Gr5, CAD . . . . .	1
20	6008253	P-CLAMP, hose . . . . .	1
21	12339426	SPEEDNUT . . . . .	10
22	6007731	DECAL, "USE DIESEL FUEL ONLY" . . . . .	1
22	6007732	DECAL, "USE DIESEL FUEL ONLY" Canada . . . . .	1
22	6007734	DECAL, "DIESEL FUEL ONLY" Arabic . . . . .	1
23	N/S	SCREW, tapping, flanged hex head, #10 - 12 x 1, CAD	4
24	6009796	CAP ASSEMBLY, fuel filler, w/tether . . . . .	1
25	6006715B9	BRACKET, shield mounting, outer . . . . .	2
26	N/S	RIVET, blind, 3/16" . . . . .	7
27	6006709	SHIELD, fuel filler tube . . . . .	1
28	6006707	BRACKET, shield mounting, inner . . . . .	1

# 2001 HUMMER PARTS CATALOG

## 3-24 FUEL, EMISSIONS AND EXHAUST

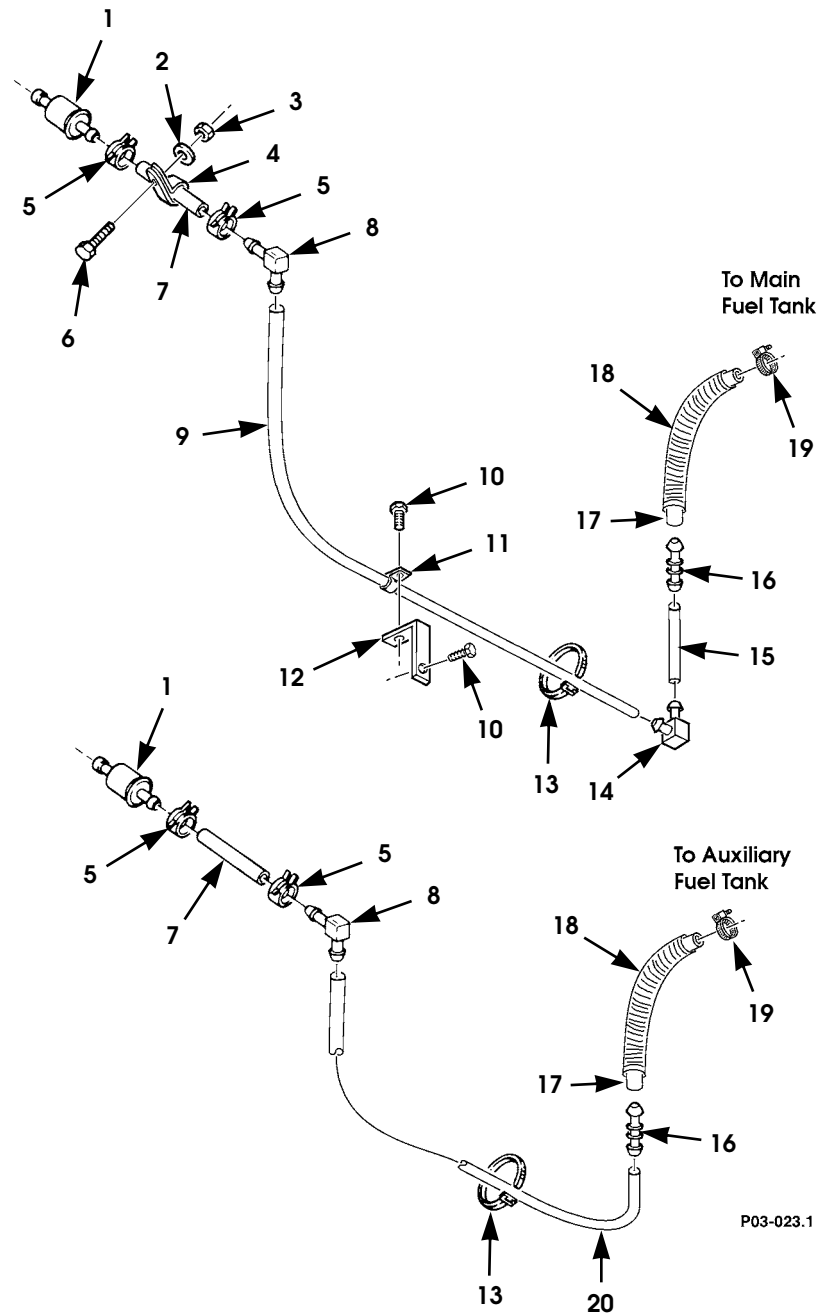

Figure 3-11. Fuel Tank Vent Line, Filter, and Mounting Hardware.

# 2001 HUMMER PARTS CATALOG

## FUEL, EMISSIONS AND EXHAUST 3-25

ITEM	PART NUMBER	DESCRIPTION	QTY
		<b>Figure 3-11. Fuel Tank Vent Line, Filter, and Mounting Hardware.</b>	
1	12339208	FILTER, fuel tank vent line . . . . .	2
2	N/S	WASHER, flat, hardened, 1/4, ZN . . . . .	1
3	N/S	LOCKNUT, 1/4, Gr8 . . . . .	1
4	N/S	CLAMP, cushioned, 3/4, vent line filter . . . . .	1
5	WWC440-1/2	CLAMP, hose vent line filter . . . . .	2
6	N/S	SCREW, 1/4 - 20 x 5/8, Gr5, CAD, filter clamp . . . . .	1
7	N/S	HOSE, 1/4" I.D. x 2.13", SEE NOTE 1 . . . . .	2
8	12339979-2	ELBOW, vent line . . . . .	2
9	N/S	TUBE, 3/8" O.D. x 83", main fuel tank, SEE NOTE 2 . . . . .	1
10	N/S	SCREW, tapping, 3/8 - 16 x 5/8, ZN . . . . .	2
11	N/S	CLAMP, cushioned, 3/8, fuel tank vent tube . . . . .	1
12	12338663	BRACKET, vent tube . . . . .	1
13	MS3367-7	TIEDOWN STRAP, vent tube . . . . .	6
14	6007133	TEE, barbed, 3/8 . . . . .	1
15	N/S	TUBING, 7-inch, SEE NOTE 2 . . . . .	1
16	6007176	REDUCER, 5/16" x 1/4" . . . . .	2
17	6006738	HOSE, rollover-to-fuel bundle . . . . .	2
18	6006739	CONDUIT, vent tubing . . . . .	2
19	N/S	CLAMP, hose . . . . .	2
20	N/S	TUBING, 3/8" O.D. x 5/16" I.D. x 35 1/4", aux fuel tank, SEE NOTE 2 . . . . .	1
		NOTE 1: MAKE FROM BULK HOSE P/N 5741210, 1/4" x 50' ROLL	
		NOTE 2: ORDER BULK TUBING BY THE FOOT, P/N CPR104420-2	

# 2001 HUMMER PARTS CATALOG

## 3-26 FUEL, EMISSIONS AND EXHAUST

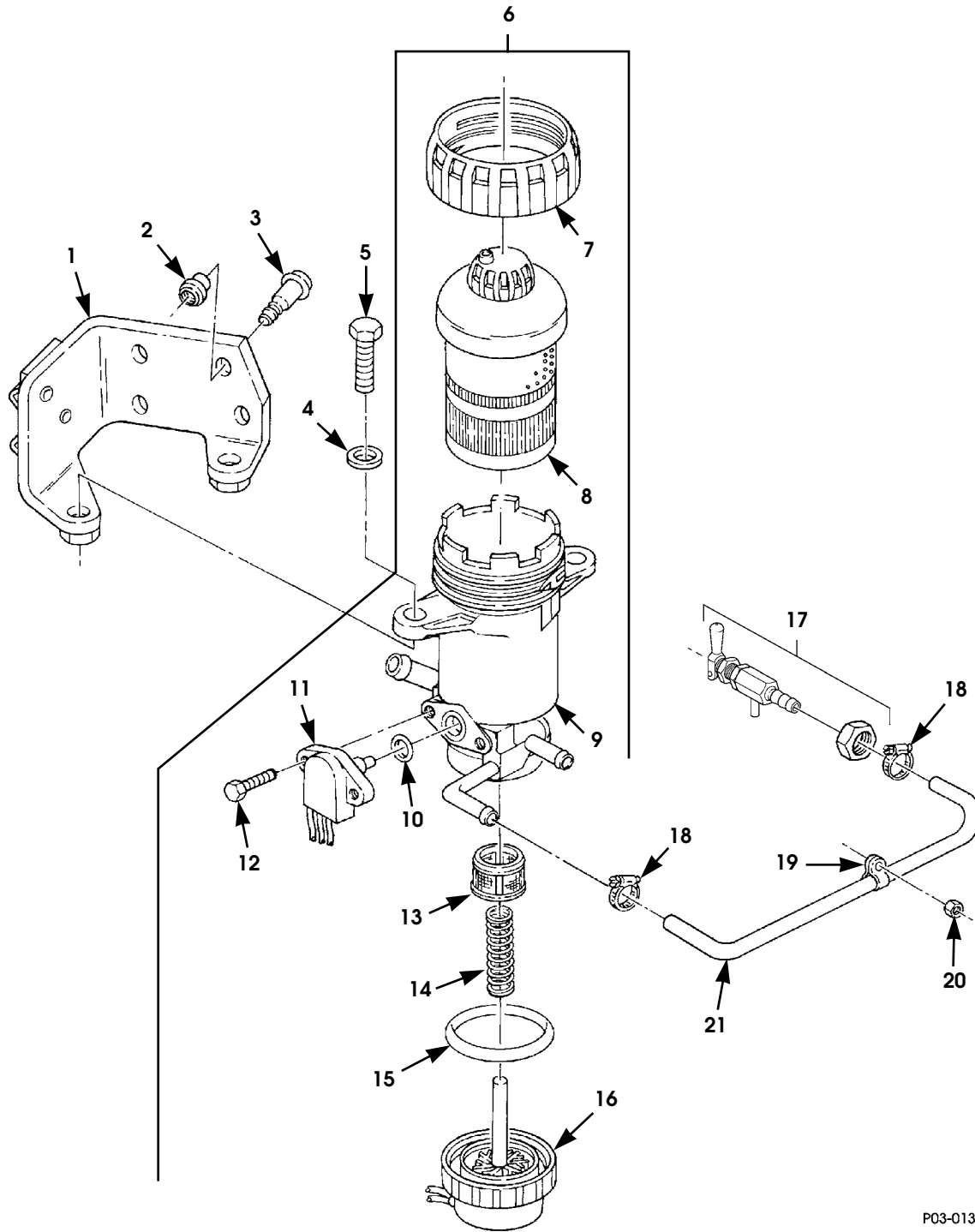

P03-013.2

Figure 3-12. Fuel Filter Assembly and Mounting Hardware.

# 2001 HUMMER PARTS CATALOG

## FUEL, EMISSIONS AND EXHAUST 3-27

ITEM	PART NUMBER	DESCRIPTION	QTY
		<b>Figure 3-12. Fuel Filter Assembly and Mounting Hardware.</b>	
1	6010657B9	BRACKET ASSEMBLY, filter mounting . . . . .	1
2	NAS1080R08	COLLAR . . . . .	4
3	M23469/2-50805	LOCKBOLT . . . . .	4
4	N/S	WASHER, flat, hard, 5/16, filter mounting, ZN . . . . .	2
5	N/S	BOLT, 5/16 - 18 x 1 1/4, Gr8, CAD, filter mounting. . . . .	2
6	5939621	FUEL FILTER ASSEMBLY . . . . .	1
7	5742599	•NUT ELEMENT . . . . .	1
8	5742602	•ELEMENT ASSEMBLY . . . . .	1
9	S.I.A.	•HEADER ASSEMBLY . . . . .	1
10	5740660	•SEAL, O-ring . . . . .	1
11	5742605	•SENSOR ASSEMBLY, water . . . . .	1
12	5742577	•SCREW . . . . .	2
13	5742604	•SCREEN . . . . .	1
14	S.I.A.	•COIL, flow guide . . . . .	1
15	5742600	•SEAL, O-ring . . . . .	1
16	5742603	•HEATER ASSEMBLY . . . . .	1
17	12446751	VALVE ASSEMBLY, fuel filter drain . . . . .	1
18	N/S	CLAMP, drain hose, 5/16, stainless . . . . .	2
19	N/S	CLAMP, drain hose, cushioned, 5/8". . . . .	1
20	N/S	LOCKNUT, 1/4 - 20, Gr8, drain hose clamp . . . . .	1
21	N/S	HOSE, fuel filter drain, 20-inch, SEE NOTE 1 . . . . .	1
		 NOTE 1: MAKE FROM BULK HOSE P/N 5741068, 1/4" x 25'	

# 2001 HUMMER PARTS CATALOG

## 3-28 FUEL, EMISSIONS AND EXHAUST

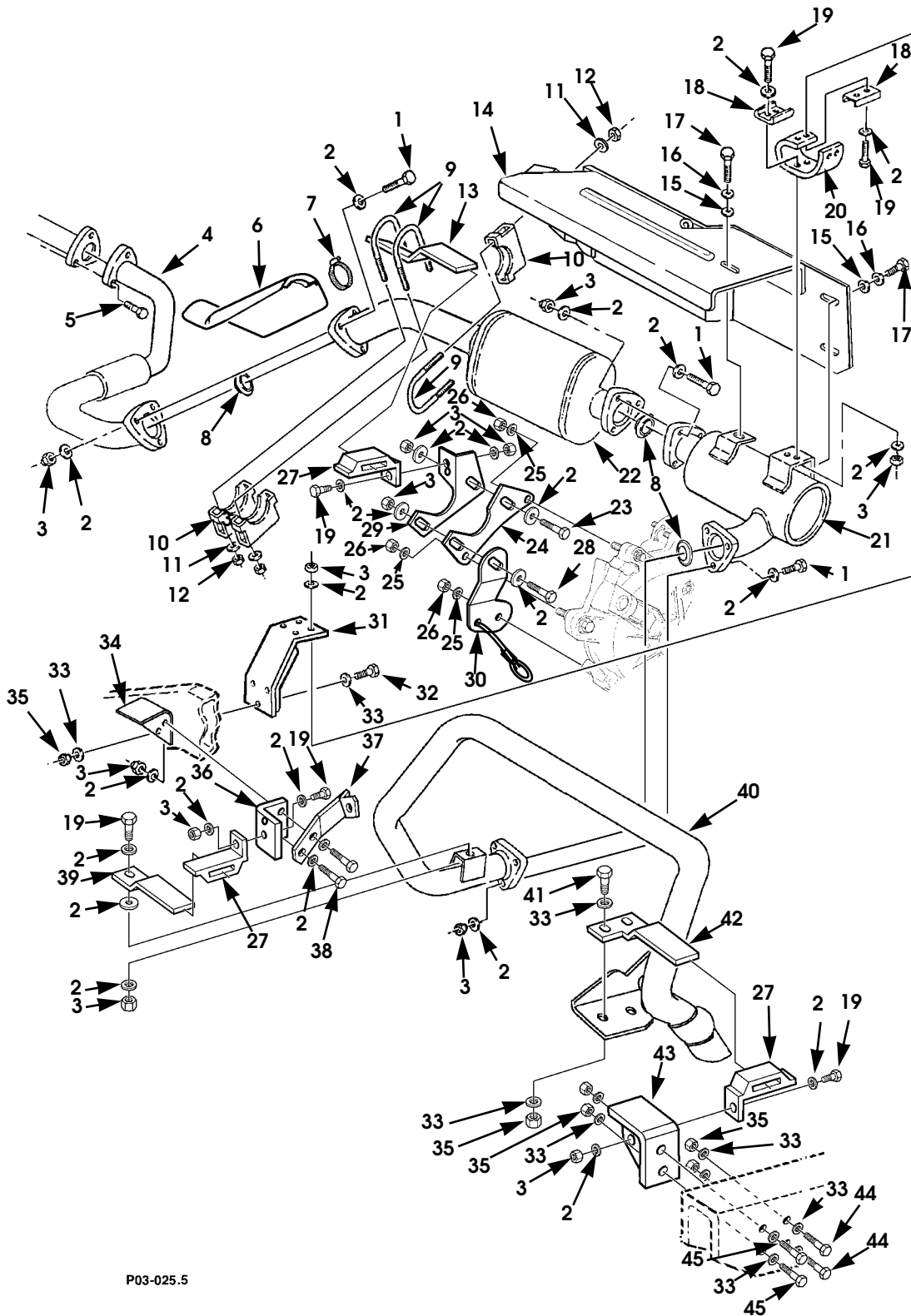

P03-025.5

Figure 3-13. Exhaust Pipes and Related Parts.

# 2001 HUMMER PARTS CATALOG

## FUEL, EMISSIONS AND EXHAUST 3-29

ITEM	PART NUMBER	DESCRIPTION	QTY
		<b>Figure 3-13.</b> <b>Exhaust Pipes and Related Parts.</b>	
1	N/S	BOLT, 3/8 - 16 x 2 1/4, Gr5, CAD . . . . .	9
2	N/S	WASHER, flat, type B, 3/8 . . . . .	50
3	N/S	LOCKNUT, 3/8 - 16, Gr8 . . . . .	20
4	RCSK17079	PIPE ASSEMBLY, crossover . . . . .	1
5	N/S	BOLT, M10 - 1.5 x 50, class 10.9, phos . . . . .	3
6	12460087	SHIELD, exhaust . . . . .	1
7	6005191	CLAMP, hose . . . . .	2
8	12338339	GASKET . . . . .	3
9	6010419	CLAMP ASSEMBLY, U-bolt . . . . .	4
10	S.I.A.	•CLAMP END . . . . .	4
11	S.I.A.	•WASHER . . . . .	8
12	S.I.A.	•NUT . . . . .	8
13	6009367	BRACKET, converter mounting, slide-bar type . . . . .	1
14	RCSK18554	HEAT SHIELD ASSEMBLY . . . . .	1
15	N/S	WASHER, flat, hardened, 1/4, ZN . . . . .	3
16	N/S	LOCKWASHER, med, 1/4, ZN . . . . .	3
17	N/S	BOLT, 1/4 - 20 x 3/4, Gr5 . . . . .	3
18	12338341	PLATE, reinforcement. . . . .	3
19	N/S	BOLT, 3/8 - 16 x 1 1/4, Gr8, CAD . . . . .	10
20	12338337	INSULATOR, exhaust . . . . .	1
21	6008296	MUFFLER ASSEMBLY, ceramic . . . . .	1
22	6008247	CATALYTIC CONVERTER ASSEMBLY . . . . .	1
23	N/S	BOLT, 3/8 - 16 x 2, Gr5, CAD . . . . .	1
24	12338347	BRACKET, exhaust . . . . .	1
25	N/S	WASHER, flat, M10 . . . . .	10
26	N/S	LOCKNUT, M10 - 1.5, class 9.8, CAD . . . . .	7
27	6009378	CUSHIONED LOOP ASSEMBLY . . . . .	3
28	N/S	BOLT, 3/8 - 16 x 1 3/4, Gr5, CAD . . . . .	1
29	6009372	BRACKET, exhaust, transfer case . . . . .	1
30	12447180	CABLE GUIDE, transfer case . . . . .	1
31	12338221B9	BRACKET, muffler mounting . . . . .	1
32	N/S	BOLT, 1/2 - 13 x 4 3/4, Gr8, CAD, L.H., body mount bracket . . . . .	3
33	N/S	WASHER, flat, hardened, 1/2, type B . . . . .	18
34	WA12342509B9	BRACKET, body mount, rear, L.H., C-mount . . . . .	1
34	6008610	BRACKET, body mount, C-mount, L.H., 12,100-lb GVW . . . . .	1



# 2001 HUMMER PARTS CATALOG

## 3-30 FUEL, EMISSIONS AND EXHAUST

ITEM	PART NUMBER	DESCRIPTION	QTY
		<b>Figure 3-13.</b> <b>Exhaust Pipes and Related Parts.(Cont'd)</b>	
35	N/S	LOCKNUT, 1/2 - 13, Gr8, CAD . . . . .	11
36	6009377	BRACKET, exhaust-to-frame . . . . .	1
37	6007737	BRACKET ASSEMBLY, CTIS mounting . . . . .	1
38	N/S	BOLT, 1/2 - 13 x 2, Gr5, CAD . . . . .	2
39	6009368	BRACKET, front tailpipe, slide-bar type . . . . .	1
40	6008565	EXHAUST PIPE ASSEMBLY . . . . .	1
41	N/S	BOLT, 1/2 - 13 x 1 1/2, Gr8, CAD . . . . .	2
42	6009369	BRACKET, rear tailpipe, slide-bar type . . . . .	1
43	6009375	BRACKET, tailpipe-to-bumper . . . . .	1
44	N/S	BOLT, 1/2 - 13 x 3, Gr8, CAD . . . . .	2
45	N/S	BOLT, 1/2 - 13 x 3 1/4, Gr8, CAD . . . . .	2

# 2001 HUMMER PARTS CATALOG

## COOLING SYSTEM 4-1

### Section 4

## COOLING SYSTEM

TITLE	PAGE NUMBER
Cooling Fan, Fan Clutch, Belt, and Pulleys . . . . .	4-14
Oil Cooler (Engine and Transmission) and Engine Oil Cooler Lines . . . . .	4-16
Radiator and Mounting Hardware . . . . .	4-2
Radiator Hoses and Related Parts . . . . .	4-8
Radiator Shroud and Related Parts . . . . .	4-6
Surge Tank and Related Parts . . . . .	4-4
Thermostat, Water Crossover, and Attaching Hardware . . . . .	4-10
Water Pump and Attaching Hardware . . . . .	4-12

# 2001 HUMMER PARTS CATALOG

## 4-2 COOLING SYSTEM

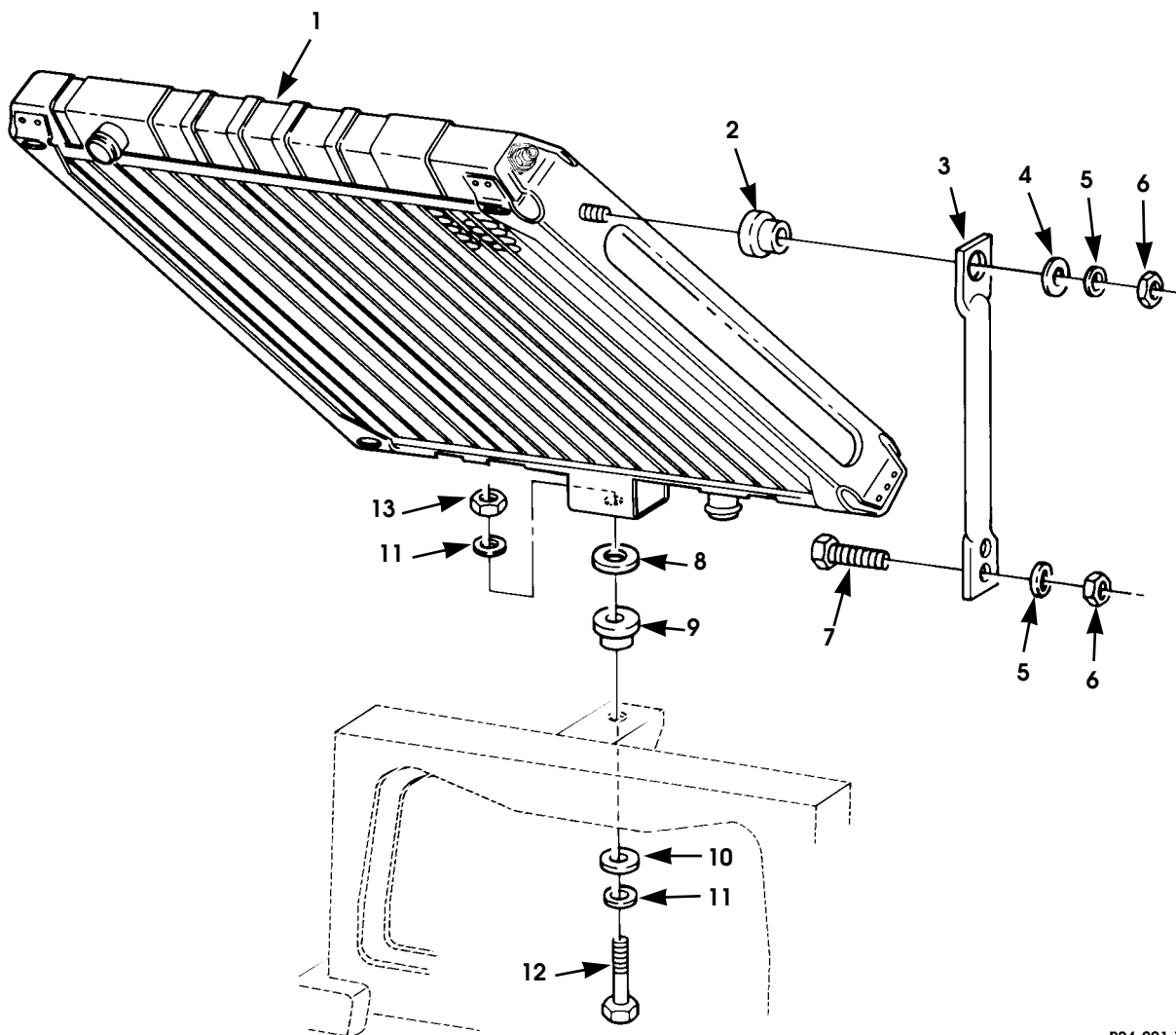

P04-001.1

*Figure 4-1. Radiator and Mounting Hardware.*

# 2001 HUMMER PARTS CATALOG

## COOLING SYSTEM 4-3

ITEM	PART NUMBER	DESCRIPTION	QTY
		<b>Figure 4-1. Radiator and Mounting Hardware.</b>	
1	6007331	RADIATOR ASSEMBLY. . . . .	1
2	12338338	GROMMET, insulator, upper . . . . .	2
3	12339165 1	SUPPORT, radiator, L.H. . . . .	1
3	12339165 2	SUPPORT, radiator, R.H. . . . .	1
4	N/S	WASHER, hardened, 3/8, ZN . . . . .	2
5	N/S	WASHER, flat, hardened, 3/8, ZN. . . . .	6
6	N/S	LOCKNUT, 3/8 - 16, Gr8, CAD . . . . .	6
7	N/S	BOLT, 3/8 - 16 x 1, Gr5, Phos. . . . .	4
8	12340263	WASHER, flat, hardened . . . . .	1
9	12340264	MOUNT, insulator, lower. . . . .	1
10	N/S	WASHER, flat, hardened, 9/16. . . . .	1
11	N/S	WASHER, flat, hardened, 1/2, ZN. . . . .	2
12	N/S	BOLT, 1/2 - 13 x 2, Gr8, CAD. . . . .	1
13	N/S	LOCKNUT, 1/2 - 13, Gr8, CAD . . . . .	1

# 2001 HUMMER PARTS CATALOG

## 4-4 COOLING SYSTEM

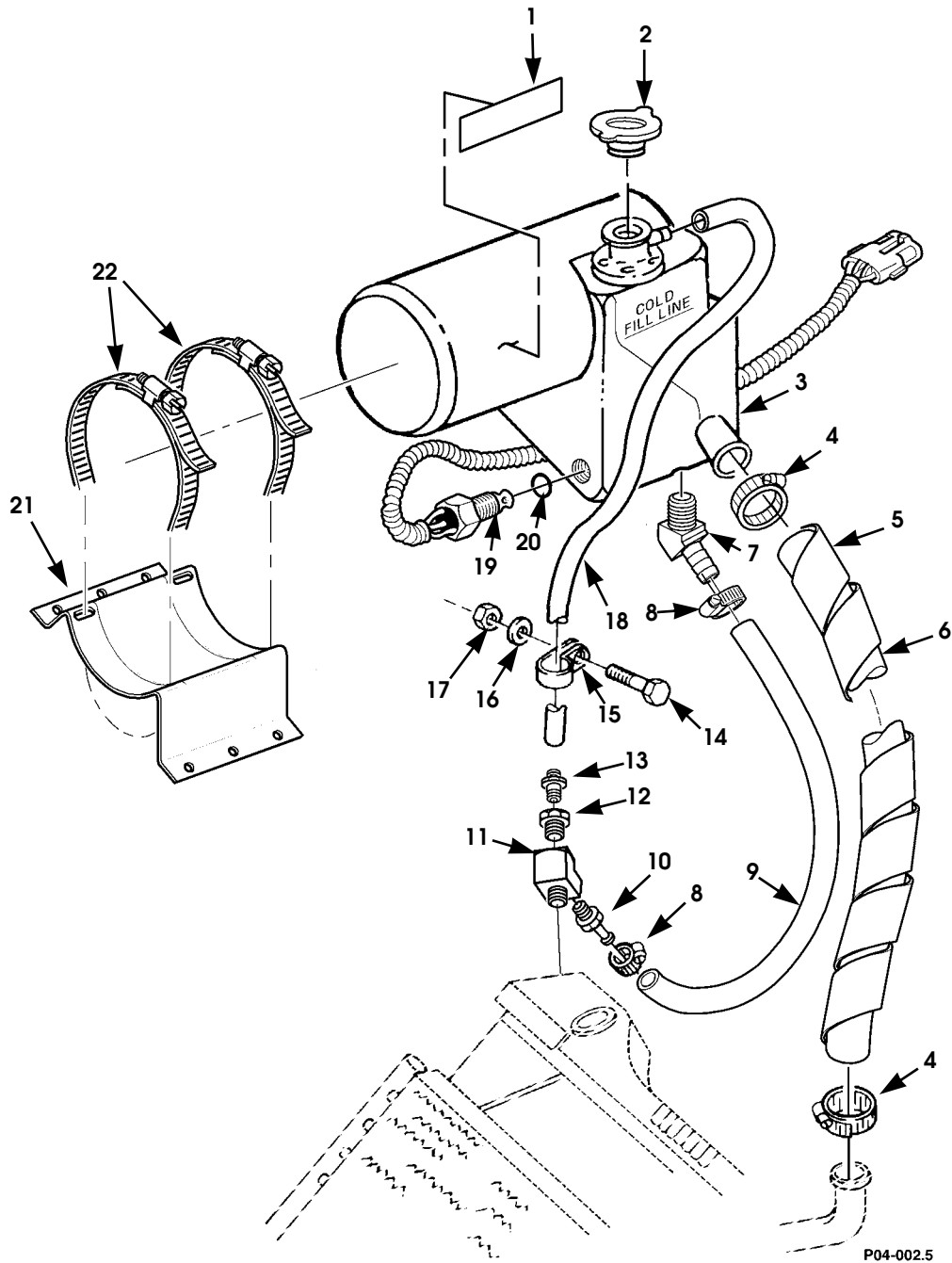

Figure 4-2. Surge Tank and Related Parts.

# 2001 HUMMER PARTS CATALOG

## COOLING SYSTEM 4-5

ITEM	PART NUMBER	DESCRIPTION	QTY
		<b>Figure 4-2. Surge Tank and Related Parts.</b>	
1	6001710	DECAL, surge tank, do not remove or touch when hot	1
2	12339878	CAP, surge tank	1
3	6008582	TANK, surge	1
4	N/S	CLAMP, hose, .62"-1.5", stainless	2
5	5742924	CHAFEGUARD, spiral wrap	3
6	12340046	HOSE, lower radiator-to-surge tank	1
7	6009102	FITTING, 45° male connector	1
8	N/S	CLAMP, hose, 5/16", stainless	2
9	12339155-1	HOSE, surge tank to radiator	1
10	12339974-1	FITTING, surge tank line to radiator	1
11	4-4-4-130424B	TEE, 1/4 x 1/4 x 1/4	1
12	5937262	BUSHING, 1/4 x 1/8	1
13	6008770	BLEEDER ASSEMBLY	1
14	N/S	BOLT, 1/4 - 20 x 3/4, Gr8, CAD	1
15	N/S	CLAMP, surge tank overflow hose, cushioned, 1/2"	1
16	N/S	WASHER, flat, hard, 1/4, ZN	1
17	N/S	LOCKNUT, 1/4 - 20, Gr8	1
18	6004920	HOSE, surge tank overflow, 12"	1
19	6008600	SENSOR, low coolant	1
20	6008584	SEAL, O-ring	1
21	12338713P	BRACKET, surge tank	1
22	N/S	CLAMP, 2.0"-6.6", stainless	2

# 2001 HUMMER PARTS CATALOG

## 4-6 COOLING SYSTEM

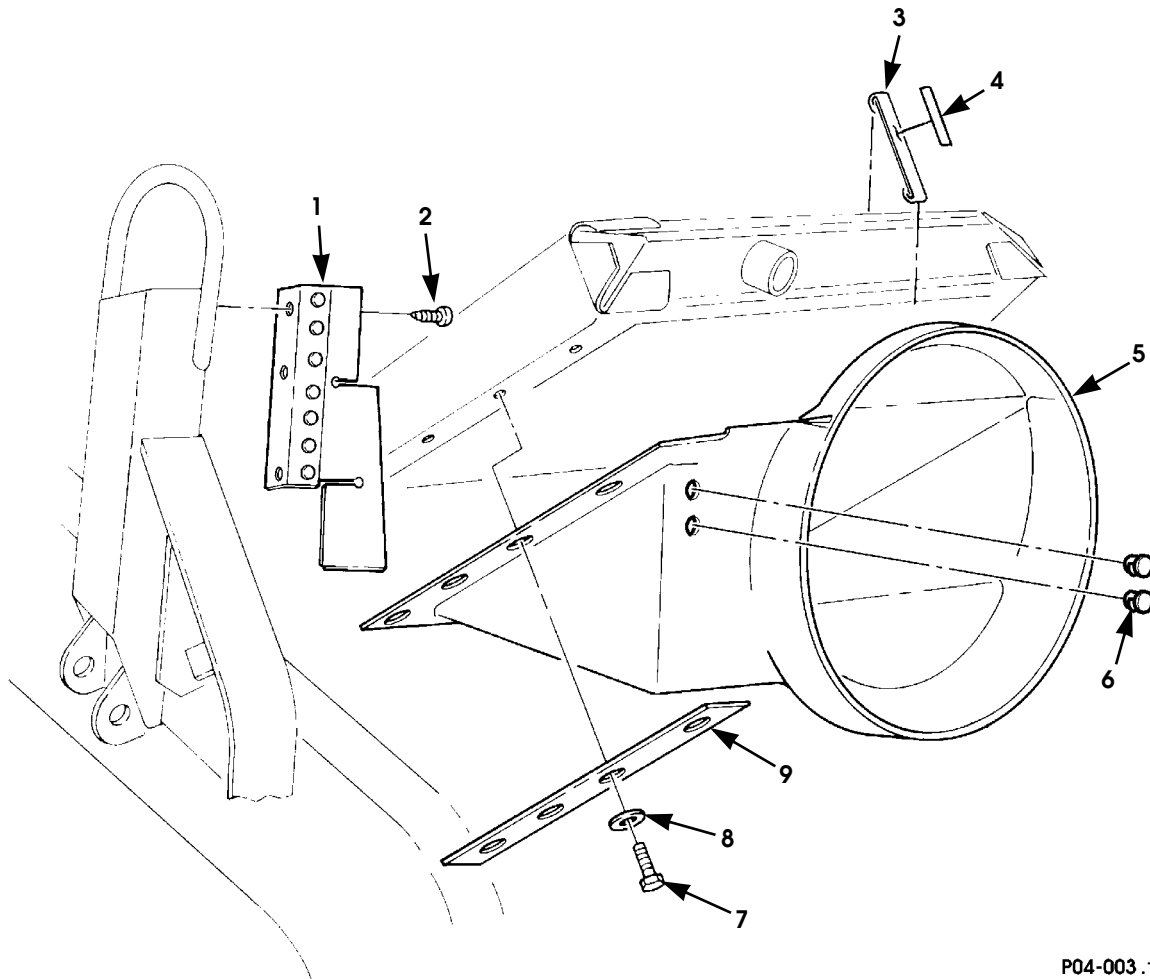

P04-003 .1

Figure 4-3. Radiator Shroud and Related Parts.

# 2001 HUMMER PARTS CATALOG

## COOLING SYSTEM 4-7

ITEM	PART NUMBER	DESCRIPTION	QTY
		<b>Figure 4-3. Radiator Shroud and Related Parts.</b>	
1	WA12339166-1	SHIELD, shroud, airlift, L.H. ....	1
1	WA12339166-2	SHIELD, shroud, airlift, R.H. ....	1
2	N/S	SCREW, pan head tapping, 1/4 - 20 x 1/2, CAD ....	6
3	EC12339154-1B1	RETAINING STRAP, radiator ....	1
4	12339064	DECAL, fan warning ....	1
4	5598360	DECAL, fan warning (Arabic) ....	1
4	6002724	DECAL, fan warning (French) ....	1
5	6003497	SHROUD, radiator ....	1
6	12339361-6	PLUG, fan shroud holes ....	2
7	N/S	BOLT, 1/4 - 20 x 1, Gr5, CAD. ....	8
8	N/S	LOCKWASHER, med, 1/4, ZN ....	8
9	12339156	RETAINING STRAP, shroud-to-radiator. ....	2



# 2001 HUMMER PARTS CATALOG

## 4-8 COOLING SYSTEM

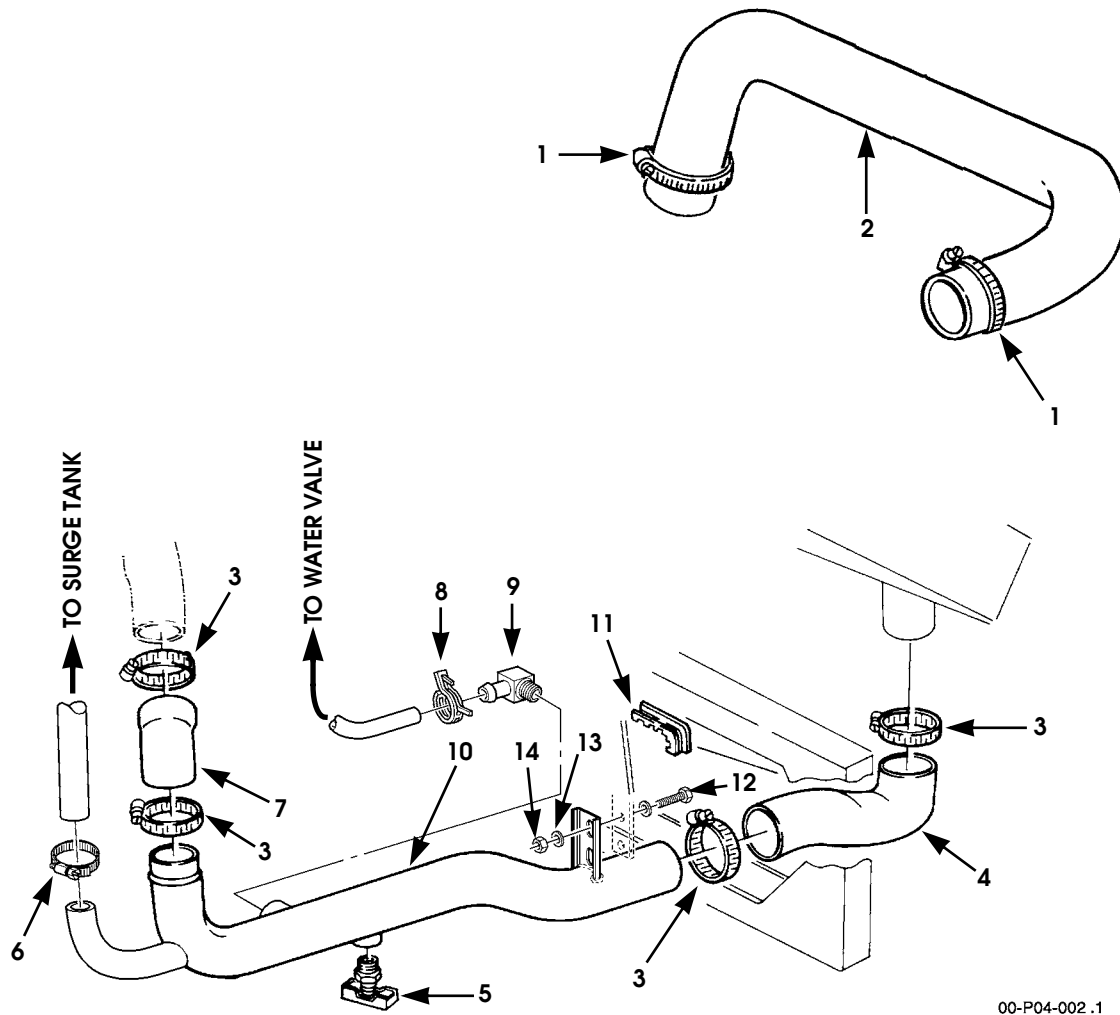

Figure 4-4. Radiator Hoses and Related Parts.

# 2001 HUMMER PARTS CATALOG

## COOLING SYSTEM 4-9

ITEM	PART NUMBER	DESCRIPTION	QTY
		<b>Figure 4-4. Radiator Hoses and Related Parts.</b>	
1	N/S	CLAMP,hose, stainless, 1.56"-2.5" . . . . .	7
2	6007014	HOSE, radiator inlet . . . . .	1
3	N/S	CLAMP,hose, stainless, 1.81"-2.75" . . . . .	4
4	12339162	HOSE, lower radiator . . . . .	1
5	MS35782-4	DRAINCOCK, lower radiator tube . . . . .	1
6	N/S	CLAMP,hose, stainless, .62"-1.5" . . . . .	1
7	12339159	HOSE, lower radiator, rear . . . . .	1
8	N/S	CLAMP, constant tension, 3/4" . . . . .	1
9	10-8-430260	FITTING . . . . .	1
10	6010165	TUBE, lower radiator. . . . .	1
11	12339902-12	PAD, crossmember, 5.92" . . . . .	1
12	N/S	BOLT, 1/4 - 20 x 3/4. . . . .	2
13	N/S	WASHER, flat, 1/4 . . . . .	4
14	N/S	LOCKNUT, 1/4 - 20 . . . . .	2

# 2001 HUMMER PARTS CATALOG

## 4-10 COOLING SYSTEM

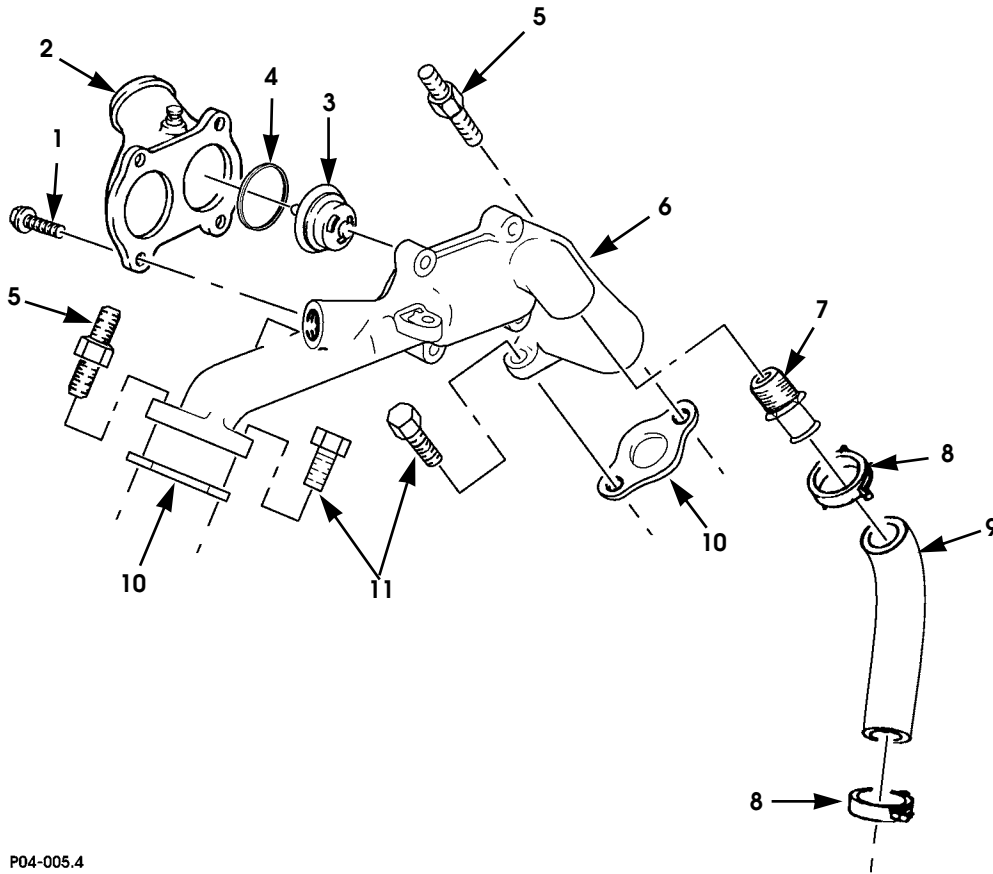

P04-005.4

Figure 4-5. Thermostat, Water Crossover, and Attaching Hardware.

# 2001 HUMMER PARTS CATALOG

## COOLING SYSTEM 4-11

ITEM	PART NUMBER	DESCRIPTION	QTY
		<b>Figure 4-5. Thermostat, Water Crossover, and Attaching Hardware.</b>	
1	5744434	BOLT, water outlet . . . . .	4
2	5744473	OUTLET ASSEMBLY, water . . . . .	1
3	5744463	THERMOSTAT. . . . .	2
4	5744462	•O-RING, enclosing, thermostat seal . . . . .	2
5	5740052	STUD . . . . .	2
6	5744461	HOUSING . . . . .	1
7	5744479	CONNECTOR, thermal bypass hose . . . . .	1
8	N/S	CLAMP, hose, 5/8 - 1-1/2, stainless . . . . .	2
9	5744460	HOSE, thermostat bypass . . . . .	1
10	5742109	GASKET, thermostat housing, SEE NOTE 1 . . . . .	2
11	5744432	BOLT, thermostat housing . . . . .	2
		 NOTE 1: PART OF CYLINDER HEAD KIT 5714842	

# 2001 HUMMER PARTS CATALOG

## 4-12 COOLING SYSTEM

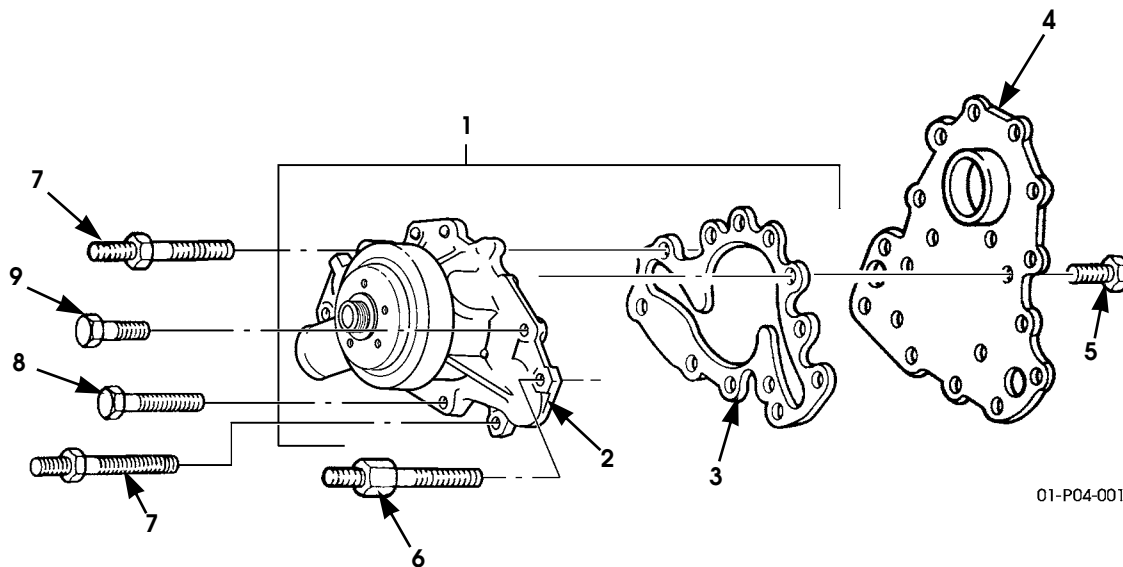

Figure 4-6. Water Pump and Attaching Hardware.

# 2001 HUMMER PARTS CATALOG

## COOLING SYSTEM 4-13

ITEM	PART NUMBER	DESCRIPTION	QTY
		<b>Figure 4-6. Water Pump and Attaching Hardware.</b>	
1	5745093	WATER PUMP ASSEMBLY .....	1
2	S.I.A.	•WATER PUMP BODY. ....	1
3	5743242	•GASKET, water pump, SEE NOTE 1 .....	1
4	5743232	BACKING PLATE, water pump .....	1
5	N/S	BOLT, M8 - 1.25 x 16, Class10.9, CAD .....	6
6	5741140	STUD, water pump .....	1
7	5741166	STUD .....	3
8	N/S	BOLT, M10 - 1.5 x 80, water pump. ....	2
9	N/S	BOLT, M8 - 1.25 x 40, Class10.9, CAD .....	2
		 NOTE 1: PART OF ENGINE OVERHAUL KIT P/N 5743399	

# 2001 HUMMER PARTS CATALOG

## 4-14 COOLING SYSTEM

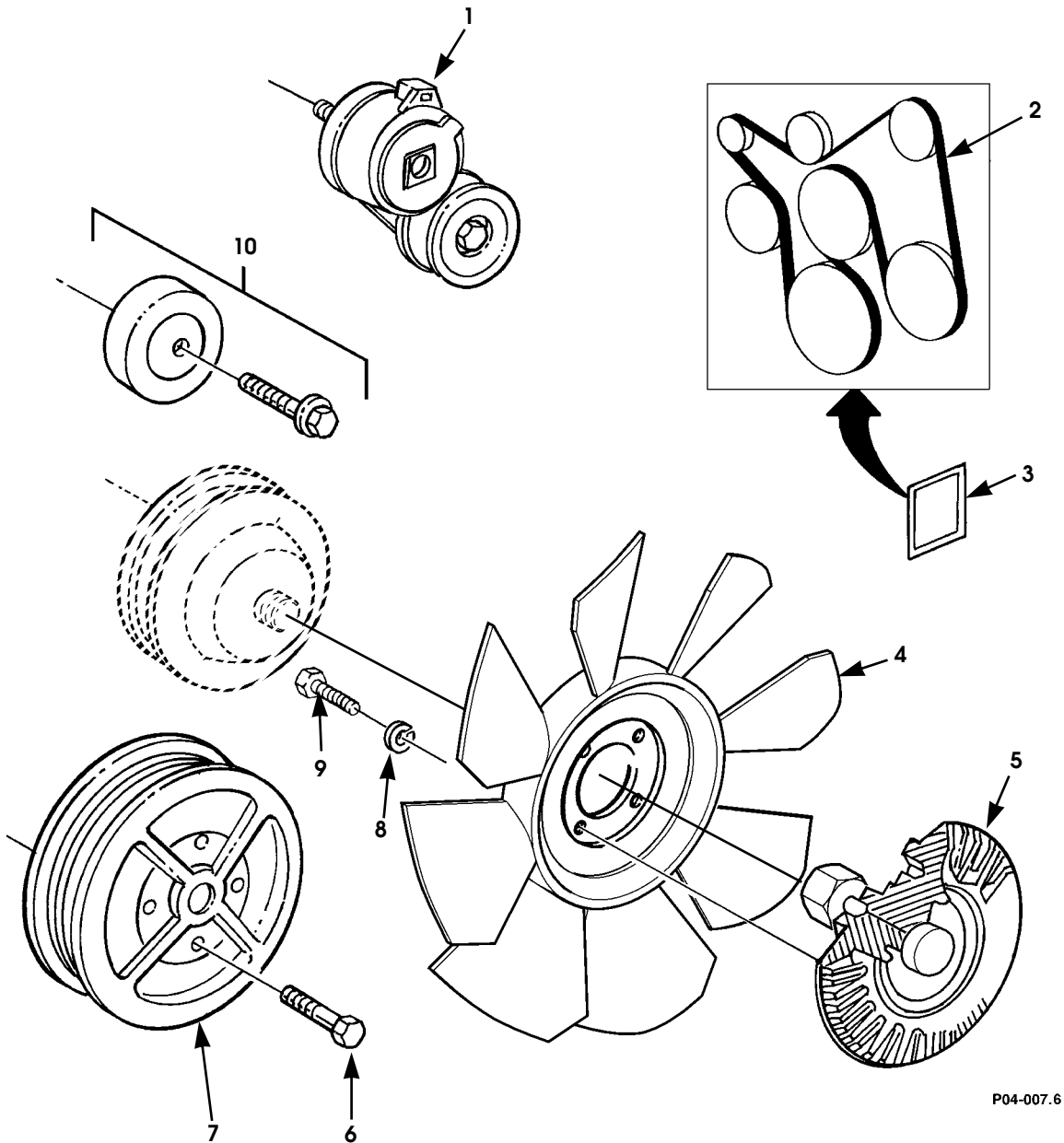

Figure 4-7. Cooling Fan, Fan Clutch, Belt, and Pulleys.

# 2001 HUMMER PARTS CATALOG

## COOLING SYSTEM 4-15

ITEM	PART NUMBER	DESCRIPTION	QTY
		<b>Figure 4-7.</b> <b>Cooling Fan, Fan Clutch, Belt, and Pulleys.</b>	
1	6003051	TENSIONER .....	1
2	6007453	BELT, serpentine .....	1
3	6006813	LABEL, belt routing .....	1
4	6009790	FAN, engine cooling, .....	1
5	6009991	CLUTCH ASSEMBLY, fan .....	1
6	N/S	BOLT, M10 - 1.5 x 65, class 9.8 .....	4
7	6003069	PULLEY, crankshaft .....	1
8	N/S	LOCKWASHER, med, 5/16 .....	4
9	N/S	BOLT, 5/16 - 18 x 5/8, fan-to-clutch. ....	4
10	6006811	IDLER ASSEMBLY .....	1



# 2001 HUMMER PARTS CATALOG

## 4-16 COOLING SYSTEM

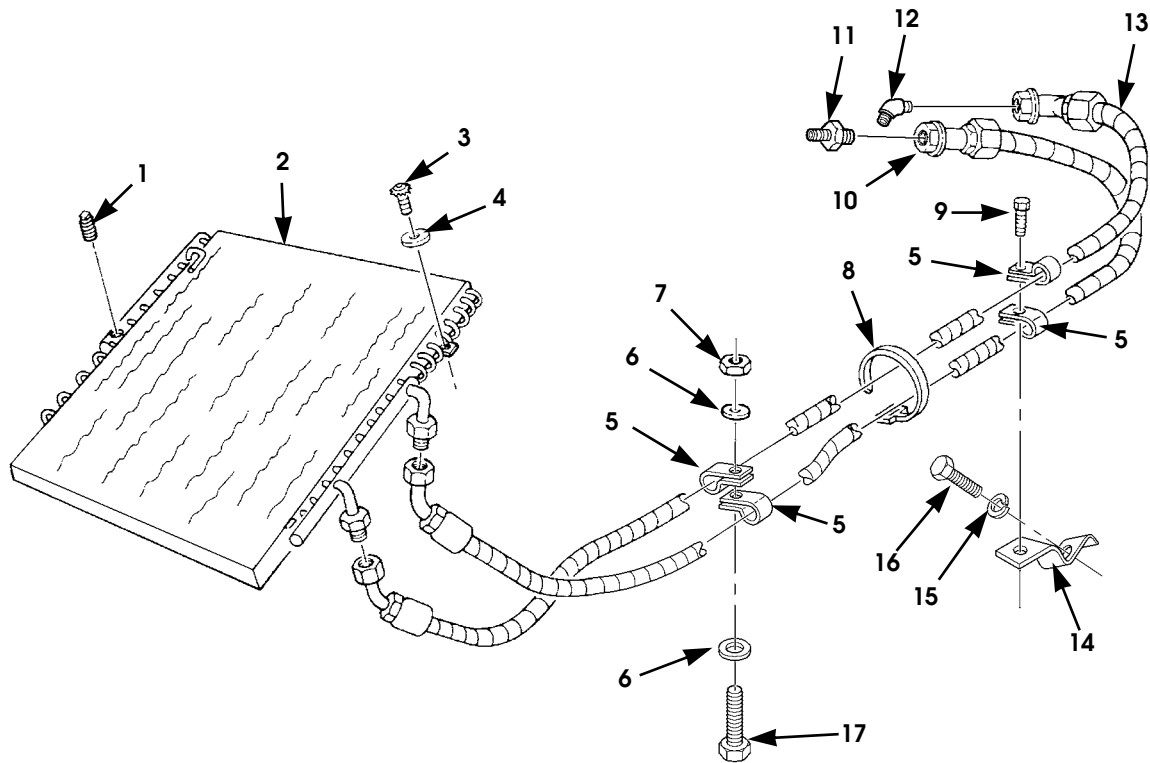

P04-008.2

Figure 4-8. Oil Cooler (Engine and Transmission) and Engine Oil Cooler Lines.

# 2001 HUMMER PARTS CATALOG

## COOLING SYSTEM 4-17

ITEM	PART NUMBER	DESCRIPTION	QTY
		<b>Figure 4-8. Oil Cooler (Engine and Transmission) and Engine Oil Cooler Lines.</b>	
1	MS49005-4	PLUG, pipe, oil cooler . . . . .	2
2	12340185	COOLER, engine and transmission oil . . . . .	1
3	N/S	BOLT, pan head, socket head, 5/16-18 x 2 1/2 . . . . .	4
4	N/S	WASHER, flat, 5/16, CAD . . . . .	4
5	12340571-2	CLAMP, closed dipped . . . . .	4
6	N/S	WASHER, flat, hardened, 1/4, ZN . . . . .	2
7	N/S	LOCKNUT, 1/4 - 20, Gr8 . . . . .	1
8	MS3367-3-9	STRAP, tiedown, oil cooler hose . . . . .	1
9	N/S	SCREW, tapping, 1/4 - 20 x 5/8, CAD, oil cooler hose clamp. . . . .	1
10	12339411-2	HOSE, oil cooler inlet . . . . .	1
11	108-070102	STRAIGHT CONNECTOR . . . . .	1
12	108-070302	ELBOW, 45-degree. . . . .	1
13	6007451	HOSE, oil cooler outlet . . . . .	1
14	6010092B9	BRACKET, oil cooler hose clamp . . . . .	1
15	N/S	LOCKWASHER, med, 3/8, ZN . . . . .	1
16	N/S	SCREW, tapping, 3/8 - 16 x 3/4, ZN. . . . .	1
17	N/S	SCREW, 1/4 - 20 x 1 1/8, Gr5, CAD . . . . .	1



# 2001 HUMMER PARTS CATALOG

## TRANSMISSION/TRANSFER CASE 5-1

### Section 5

## TRANSMISSION/TRANSFER CASE

TITLE	PAGE NUMBER
Control Valve and Related Parts . . . . .	5-14
Torque Converter . . . . .	5-2
Transfer Case Assembly, Front Half . . . . .	5-26
Transfer Case Assembly, Rear Half . . . . .	5-28
Transfer Case Assembly . . . . .	5-24
Transfer Case Oil Cooler Assembly . . . . .	5-32
Transfer Case Shift Controls . . . . .	5-36
Transfer Case Shift Mechanisms . . . . .	5-34
Transmission and Transfer Case Control Assembly and Neutral Start Switch . . . . .	5-5
Transmission External Wiring Harness . . . . .	5-16
Transmission Filter and Sensors . . . . .	5-12
Transmission Mounting Hardware, Fluid Dipstick, and Tube Assembly . . . . .	5-10
Transmission Parking Lock System . . . . .	5-18
Transmission Shifting Linkage . . . . .	5-8
Transmission Vent Lines and Attaching Hardware . . . . .	5-20
Transmission/Transfer Case Cooling Lines . . . . .	5-22

# 2001 HUMMER PARTS CATALOG

## 5-2 TRANSMISSION/TRANSFER CASE

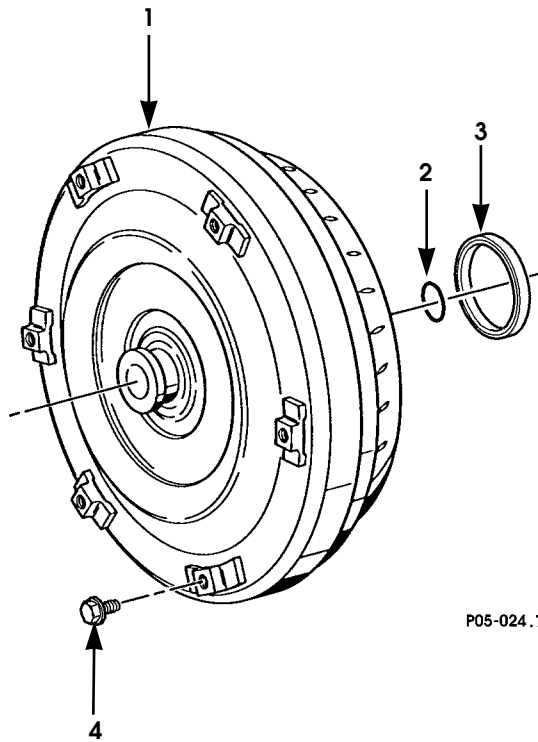

P05-024 .1

Figure 5-1. Torque Converter.

# 2001 HUMMER PARTS CATALOG

## TRANSMISSION/TRANSFER CASE 5-3

ITEM	PART NUMBER	DESCRIPTION	QTY
		<b>Figure 5-1. Torque Converter.</b>	
1	5714957	TORQUE CONVERTER, transmission (remanufactured)	1
2	5714323	O-RING, turbine shaft front oil seal . . . . .	1
3	5743361	SEAL, torque converter . . . . .	1
4	N/S	SCREW, M10-1.5" x 15, converter to flywheel. . . . .	6



# 2001 HUMMER PARTS CATALOG

## TRANSMISSION/TRANSFER CASE 5-5

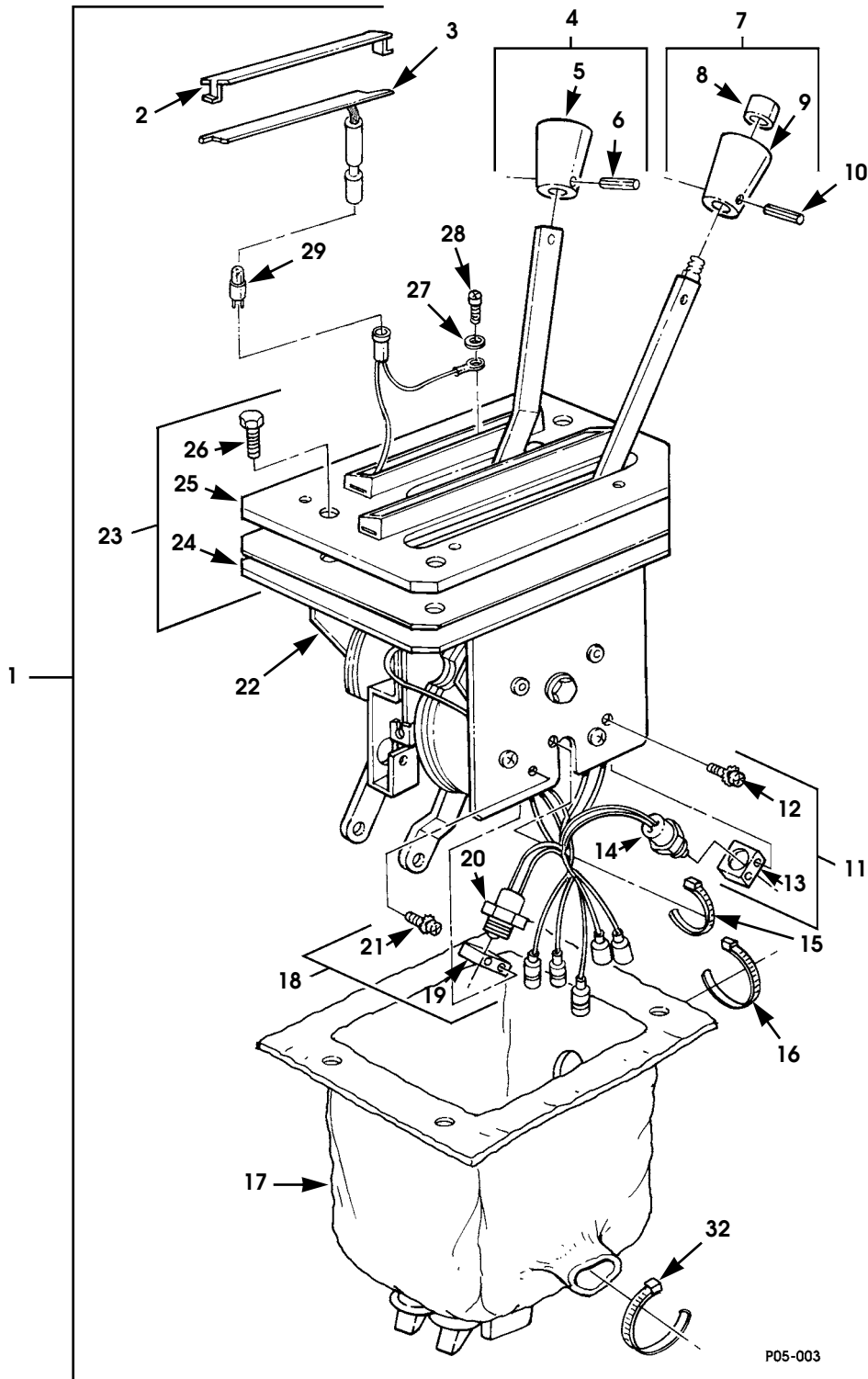

P05-003

Figure 5-2. Transmission and Transfer Case Control Assembly and Neutral Start Switch.  
(Sheet 1 of 2)



# 2001 HUMMER PARTS CATALOG

## 5-6 TRANSMISSION/TRANSFER CASE

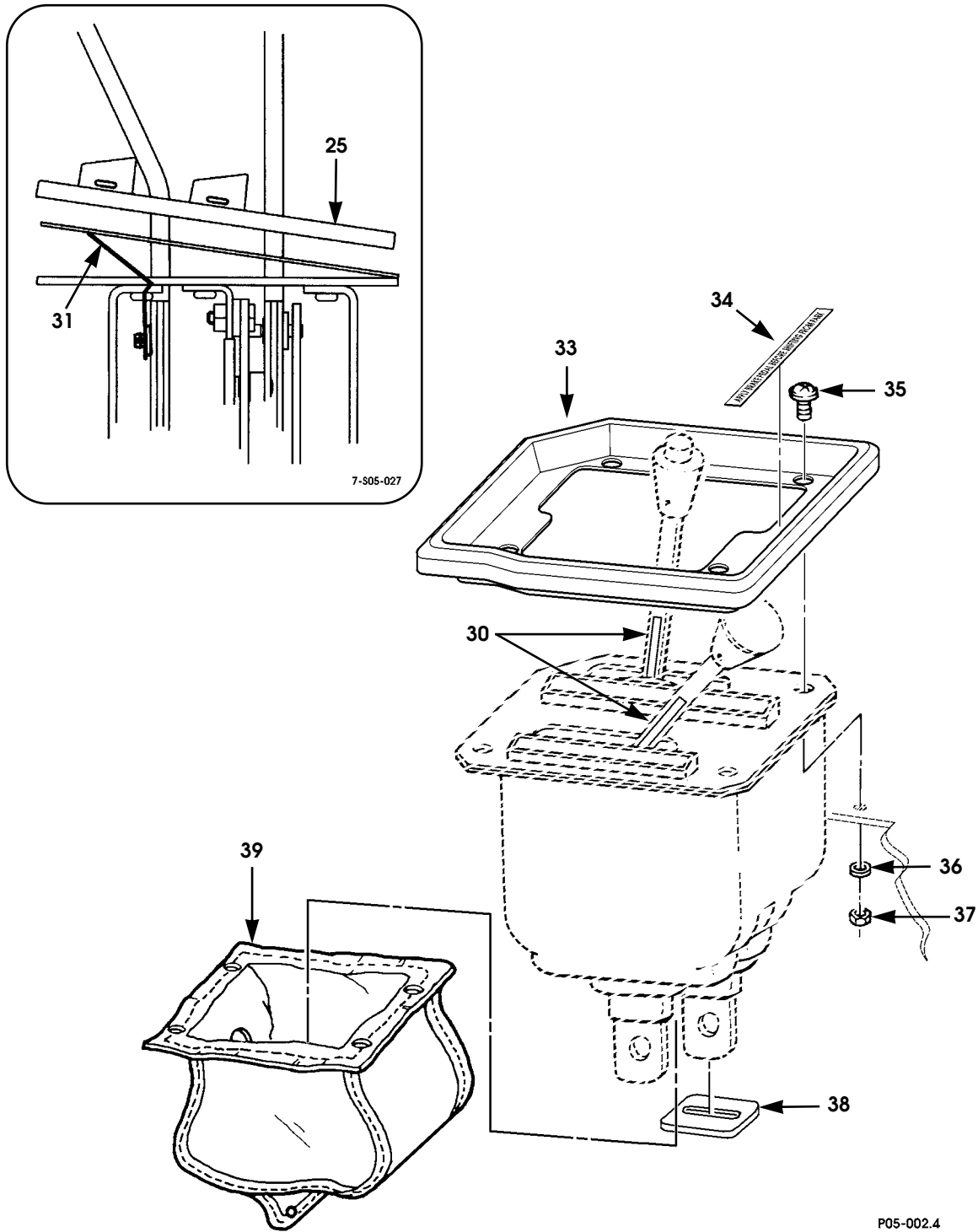

Figure 5-2. Transmission and Transfer Case Control Assembly and Neutral Start Switch.  
(Sheet 2 of 2)

# 2001 HUMMER PARTS CATALOG

## TRANSMISSION/TRANSFER CASE 5-7

ITEM	PART NUMBER	DESCRIPTION	QTY
		<b>Figure 5-2.</b> <b>Transmission and Transfer Case Control Assembly and Neutral Start Switch.</b>	
1	6009799	CONTROL ASSEMBLY, transmission and transfer case .	1
2	5743154	•LENS, transmission . . . . .	1
2	5743155	•LENS, transfer case . . . . .	1
3	5744277	•FIBEROPTICS, transmission . . . . .	1
3	5742980	•FIBEROPTICS, transfer case . . . . .	1
4	5743156	•KNOB KIT, transfer case . . . . .	1
5	S.I.K.	••KNOB, transfer shift . . . . .	1
6	S.I.K.	••SPRING PIN. . . . .	1
7	5743157	•PUSH BUTTON KNOB KIT, transmission . . . . .	1
8	S.I.K.	••RELEASE BUTTON, transmission handle . . . . .	1
9	S.I.K.	••KNOB, transmission handle. . . . .	1
10	S.I.K.	••SPRING PIN. . . . .	1
11	5743158	•SWITCH ASSEMBLY, neutral . . . . .	1
12	S.I.A.	••SCREW-ASSEMBLED WASHER . . . . .	2
13	S.I.A.	••NUT, neutral switch . . . . .	1
14	S.I.A.	••NEUTRAL SWITCH. . . . .	1
15	MS3367-4-2	•TIEDOWN STRAP, 2.72", red. . . . .	2
16	MS3367-7-0	•TIEDOWN STRAP, .192" x 10.2", black. . . . .	1
17	6007499	•BOOT, shifter control . . . . .	1
18	5743159	•SWITCH ASSEMBLY, reverse . . . . .	1
19	S.I.A.	••NUT, reverse switch . . . . .	1
20	S.I.A.	••REVERSE SWITCH . . . . .	1
21	S.I.A.	••SCREW-ASSEMBLED WASHER . . . . .	2
22	S.I.A.	•HOUSING . . . . .	1
23	5743160	•COVER PLATE SEAL KIT . . . . .	1
24	S.I.K.	••COVER SEAL. . . . .	1
25	S.I.K.	••COVER PLATE. . . . .	1
26	S.I.K.	••SCREW . . . . .	4
27	N/S	•WASHER . . . . .	1
28	N/S	•SCREW . . . . .	1
29	5744879	•BULB, indicator. . . . .	1
30	5743742	•TAPE, indicator, transmission gear shift . . . . .	2
31	6009798	•CLIP, anti-rattle, . . . . .	1
32	MS3367-1-9	TIEDOWN STRAP . . . . .	1
33	6007186	BEZEL, shift lever . . . . .	1
34	6008037	DECAL, shift instruction (English) . . . . .	1
34	6008038	DECAL, shift instruction (French) . . . . .	1
34	6008039	DECAL, shift instruction (Arabic) . . . . .	1
35	N/S	SCREW, cap, 1/4 - 20 x 7/8, Gr3, CAD, control assembly	3
36	N/S	WASHER, flat, hardened, 1/4, Type B, ZN, control assembly	3
37	N/S	LOCKNUT, 1/4 - 20, Gr8, control assembly . . . . .	3
38	12460507	BOOT PROTECTOR . . . . .	2
39	6007457	COVER, shifter boot. . . . .	1

# 2001 HUMMER PARTS CATALOG

## 5-8 TRANSMISSION/TRANSFER CASE

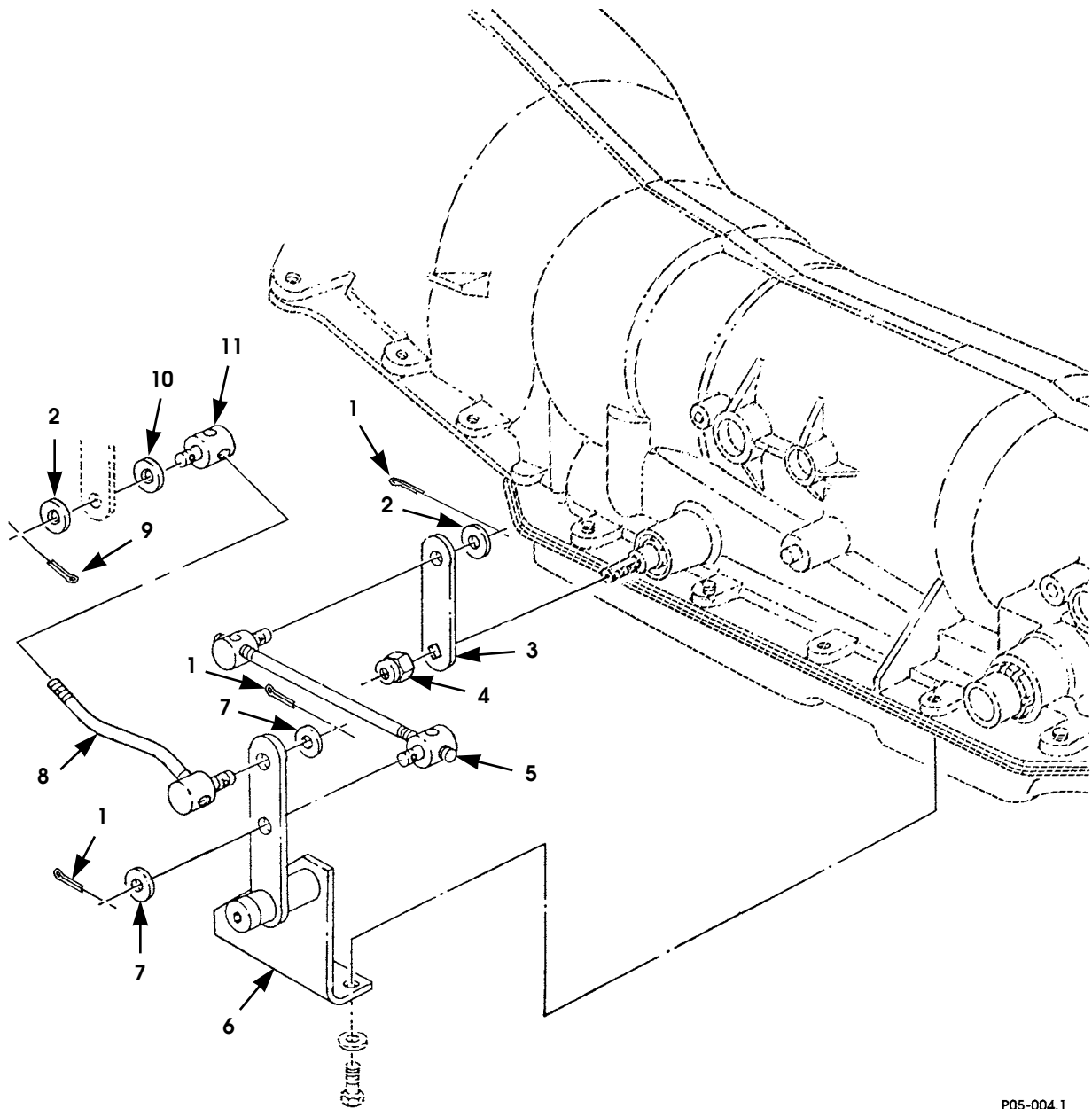

P05-004.1

Figure 5-3. Transmission Shifting Linkage.

# 2001 HUMMER PARTS CATALOG

## TRANSMISSION/TRANSFER CASE 5-9

ITEM	PART NUMBER	DESCRIPTION	QTY
		<b>Figure 5-3. Transmission Shifting Linkage.</b>	
1	N/S	PIN, cotter, 3/32" X 3/4" . . . . .	3
2	N/S	WASHER, flat, 3/8, CL2, CAD . . . . .	2
3	12447176	LEVER, transmission shift arm . . . . .	1
4	N/S	NUT, M10 - 1.5, Class 10.9, Phos. . . . .	1
5	12447178	ROD ASSEMBLY, bracket-to-transmission . . . . .	1
6	12447182	BRACKET, transmission shift lever . . . . .	1
7	N/S	WASHER, flat, 3/8, CAD . . . . .	2
8	12460146	ROD, transmission to shifter. . . . .	1
9	N/S	PIN, cotter, 1/8" x 3/4" . . . . .	2
10	N/S	WASHER, wave, 3/8, Type 2, ZN . . . . .	1
11	12338442-2	TRUNNION, shift control, transmission. . . . .	1

# 2001 HUMMER PARTS CATALOG

## 5-10 TRANSMISSION/TRANSFER CASE

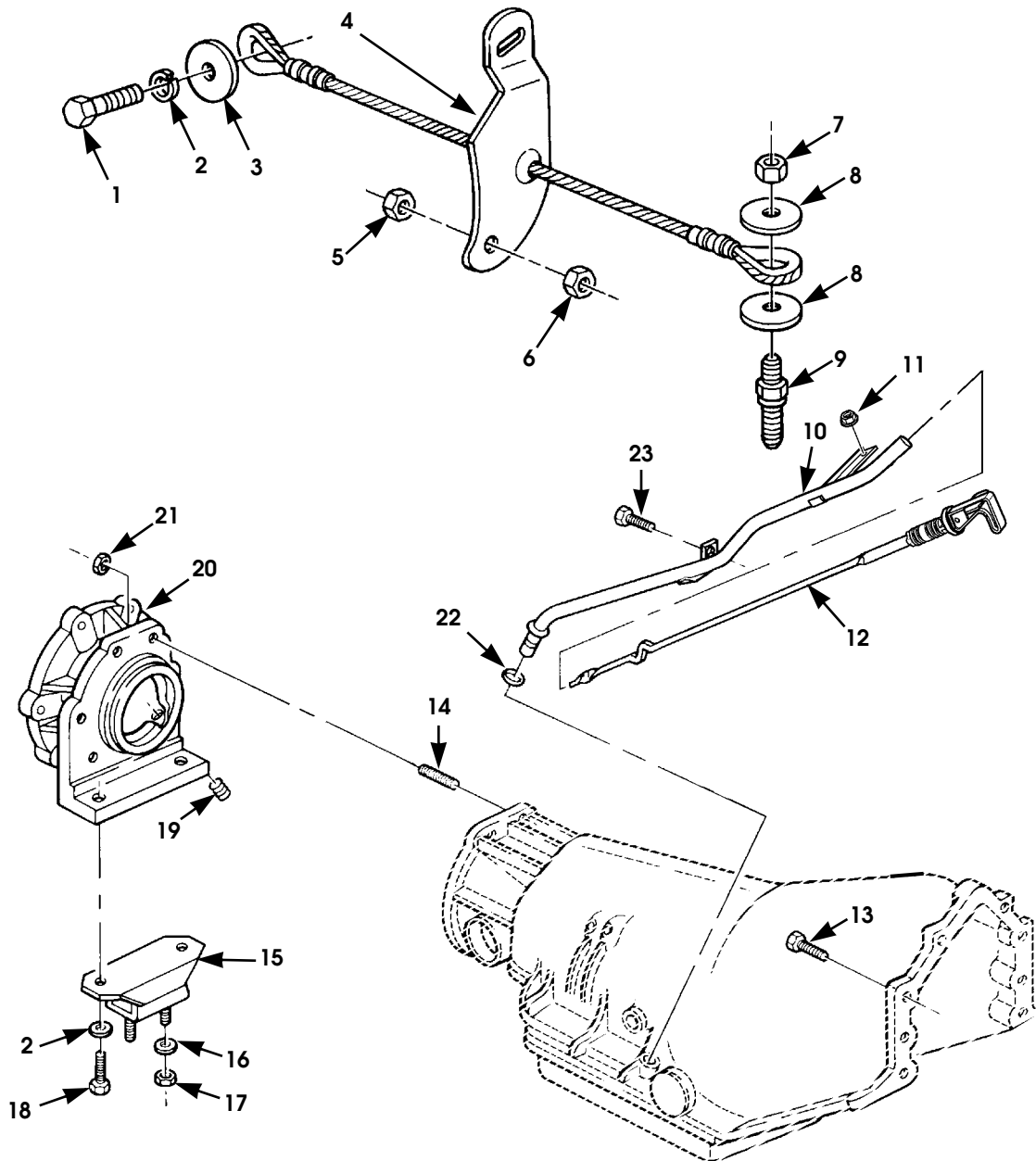

P05-006.5

Figure 5-4. Transmission Mounting Hardware, Fluid Dipstick, and Tube Assembly.

# 2001 HUMMER PARTS CATALOG

## TRANSMISSION/TRANSFER CASE 5-11

ITEM	PART NUMBER	DESCRIPTION	QTY
		<b>Figure 5-4. Transmission Mounting Hardware, Fluid Dipstick, and Tube Assembly.</b>	
1	N/S	BOLT, 1/2 - 13 x 1 3/4, Gr.8, CAD, guide cable . . . . .	1
2	N/S	LOCKWASHER, 1/2, ZN . . . . .	2
3	N/S	WASHER, flat, type B, 9/16, ZN, guide cable . . . . .	1
4	12447180	CABLE ASSEMBLY, transfer case guide . . . . .	1
5	N/S	NUT, M10 - 1.5 . . . . .	1
6	11501033	LOCKNUT, p.t., transfer case guide cable . . . . .	1
7	N/S	NUT, 7/16 - 14, Gr8, guide cable . . . . .	1
8	12340058	WASHER, special, hardened, guide cable . . . . .	1
9	12447177	STUD, special, T-case anchor cable, L.H. side only . . . . .	1
10	6010347	TUBE, transmission oil dipstick . . . . .	1
11	N/S	NUT, flanged, M10 - 1.50 . . . . .	1
12	6007925	DIPSTICK, transmission oil . . . . .	1
13	6008021	BOLT . . . . .	6
14	12460065	STUD, transmission adapter . . . . .	6
15	12339178	MOUNT, resilient, transmission, rear . . . . .	1
16	N/S	WASHER, flat, type B, 3/8 . . . . .	2
17	N/S	LOCKNUT, 3/8 - 16, Gr8 . . . . .	2
18	MS90725-110	SCREW, 1/2 - 13 x 1 1/8, Gr5, CAD . . . . .	2
19	444689	DRAINPLUG, 1/8, NPT, transmission . . . . .	1
20	12447175	ADAPTER, transmission . . . . .	1
21	N/S	LOCKNUT, p.t., flanged, 3/8 - 24, adapter . . . . .	12
22	12447172	SEAL, dipstick tube . . . . .	1
23	N/S	BOLT, flanged, M10 - 1.5 x 16, class 9.8, Phos. . . . .	1
	05573543	LOCTITE GASKET ELIMINATOR (not illustrated) . . . . .	1

# 2001 HUMMER PARTS CATALOG

## 5-12 TRANSMISSION/TRANSFER CASE

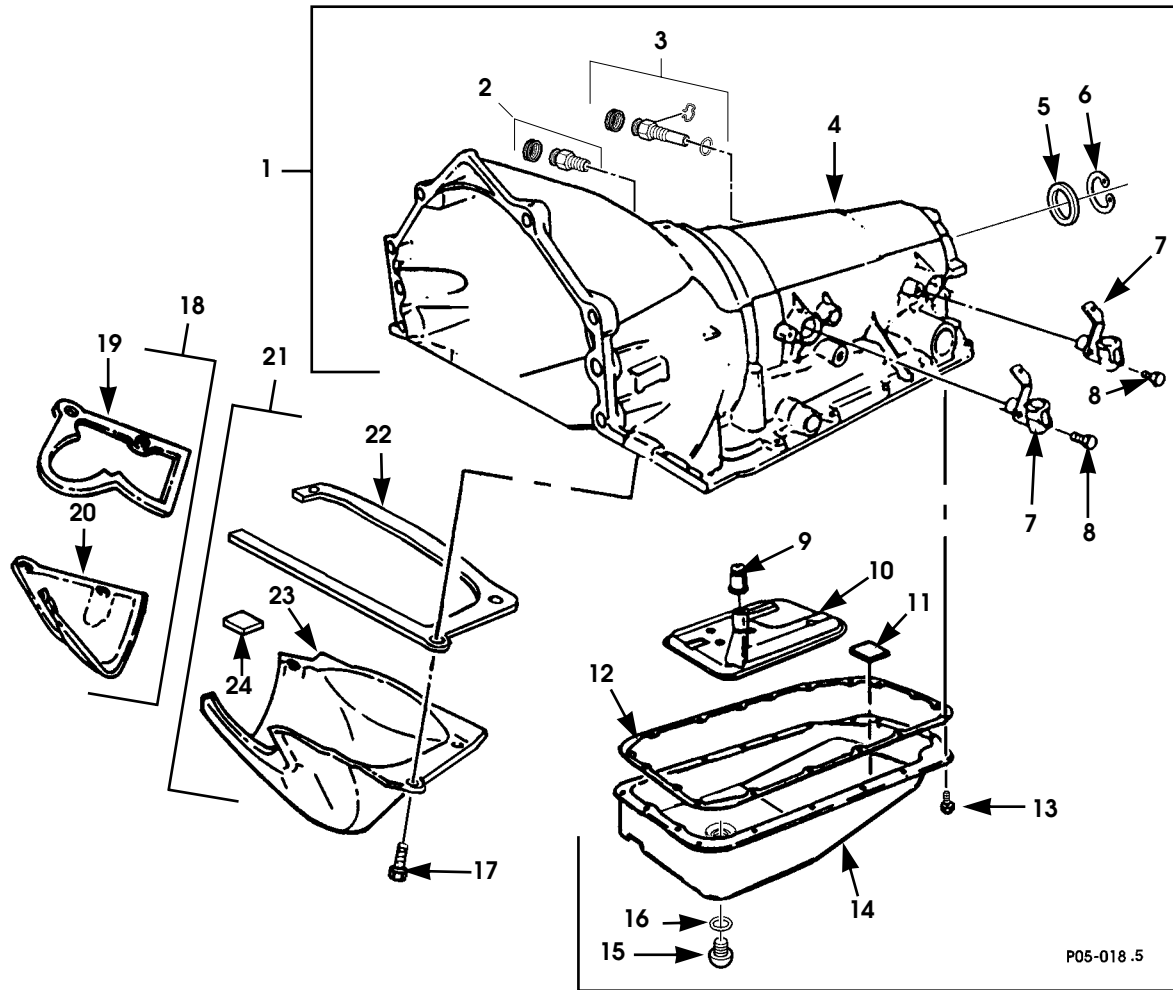

P05-018.5

Figure 5-5. Transmission Filter and Sensors.

# 2001 HUMMER PARTS CATALOG

## TRANSMISSION/TRANSFER CASE 5-13

ITEM	PART NUMBER	DESCRIPTION	QTY
		<b>Figure 5-5. Transmission Filter and Sensors.</b>	
1	5745364	TRANSMISSION, w/ torque converter, 4L80E, remanufactured. . . . .	1
1	6011646	TRANSMISSION, w/torque converter, 4L80E, new . . . . .	1
2	5714967	•FITTING, cooler pipe, front. . . . .	1
3	5714961	•FITTING, cooler pipe, rear . . . . .	1
4	S.I.A.	•CASE. . . . .	1
5	5714333	•SEAL, output shaft . . . . .	1
6	5714335	•RETAINING RING, output shaft seal . . . . .	1
7	5743516	•SENSOR ASSEMBLY. . . . .	2
8	11508805	•BOLT, speed sensor . . . . .	2
9	5743312	•SEAL, filter neck . . . . .	1
10	5714971	•KIT, filter assembly . . . . .	1
11	5744092	•MAGNET, chip collector . . . . .	1
12	5743310	•SEAL, transmission oil pan . . . . .	1
13	S.I.A.	•BOLT, oil pan, M8 - 1.25 x 20, class 9.8 . . . . .	17
14	5714952	•OIL PAN ASSEMBLY. . . . .	1
15	5714953	••DRAIN PLUG, transmission. . . . .	1
16	5714963	•••O-RING, transmission drain plug . . . . .	1
17	N/S	BOLT, flanged, M10 - 1.5 x 16, class 9.8, Phos. . . . .	6
18	12342107	COVER ASSEMBLY . . . . .	1
19	12342105	•GASKET, cover assembly. . . . .	1
20	12342107-1	•COVER ASSEMBLY . . . . .	1
21	RCSK18343	COVER ASSEMBLY, transmission . . . . .	1
22	12460095	•GASKET, torque converter cover. . . . .	1
23	S.I.A.	•COVER, torque converter. . . . .	1
24	S.I.A.	•TAB, torque converter cover . . . . .	1



# 2001 HUMMER PARTS CATALOG

## 5-14 TRANSMISSION/TRANSFER CASE

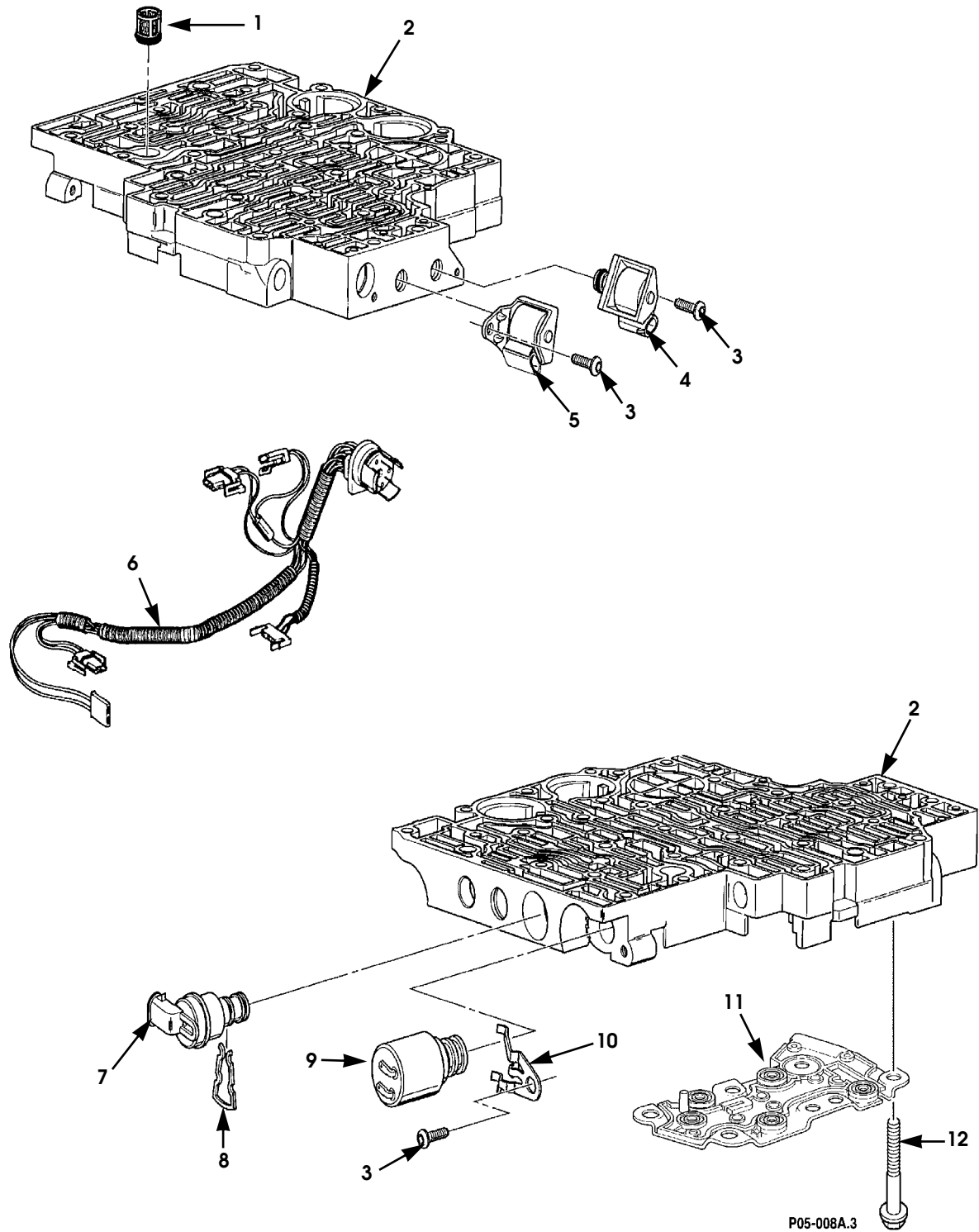

Figure 5-6. Control Valve and Related Parts.

# 2001 HUMMER PARTS CATALOG

## TRANSMISSION/TRANSFER CASE 5-15

ITEM	PART NUMBER	DESCRIPTION	QTY
		<b>Figure 5-6. Control Valve and Related Parts.</b>	
1	5714355	SCREEN FILTER . . . . .	1
2	N/S	VALVE BODY ASSEMBLY, control . . . . .	1
3	5744115	SCREW, ph Torx. . . . .	3
4	5715668	SOLENOID, shift 2-3 . . . . .	1
5	5715667	SOLENOID, shift 1-2 . . . . .	1
6	5715037	WIRING HARNESS ASSEMBLY, transmission internal . . . . .	1
7	5744093	SOLENOID ASSEMBLY, torque converter clutch . . . . .	1
8	5744095	CLIP, solenoid valve . . . . .	1
9	5714373	VALVE, pressure control solenoid . . . . .	1
10	5714354	CLAMP, pressure control solenoid . . . . .	1
11	5744098	SWITCH, fluid pressure, manual valve position. . . . .	1
12	5744085	BOLT, valve body . . . . .	3

# 2001 HUMMER PARTS CATALOG

## 5-16 TRANSMISSION/TRANSFER CASE

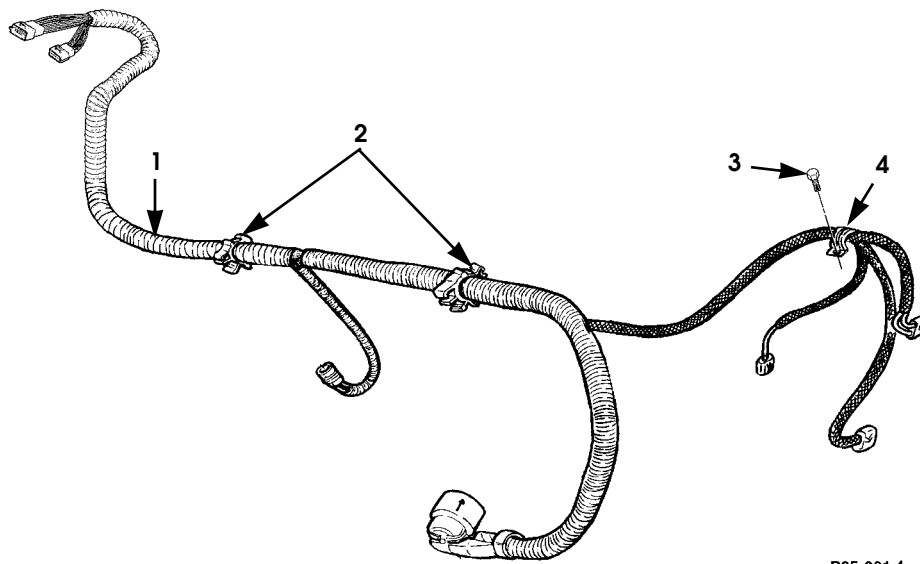

P05-021.4

*Figure 5-7. Transmission External Wiring Harness.*

# 2001 HUMMER PARTS CATALOG

## TRANSMISSION/TRANSFER CASE 5-17

ITEM	PART NUMBER	DESCRIPTION	QTY
		<b>Figure 5-7.</b> <b>Transmission External Wiring Harness.</b>	
1	6010027	HARNESS ASSEMBLY, transmission .....	1
2	6003234	CLIP, convoluted tubing .....	2
3	N/S	BOLT, tapping, 3/8 - 16 x 3/4 .....	1
4	N/S	CLAMP, cushioned, 7/16" rubber .....	1

# 2001 HUMMER PARTS CATALOG

## 5-18 TRANSMISSION/TRANSFER CASE

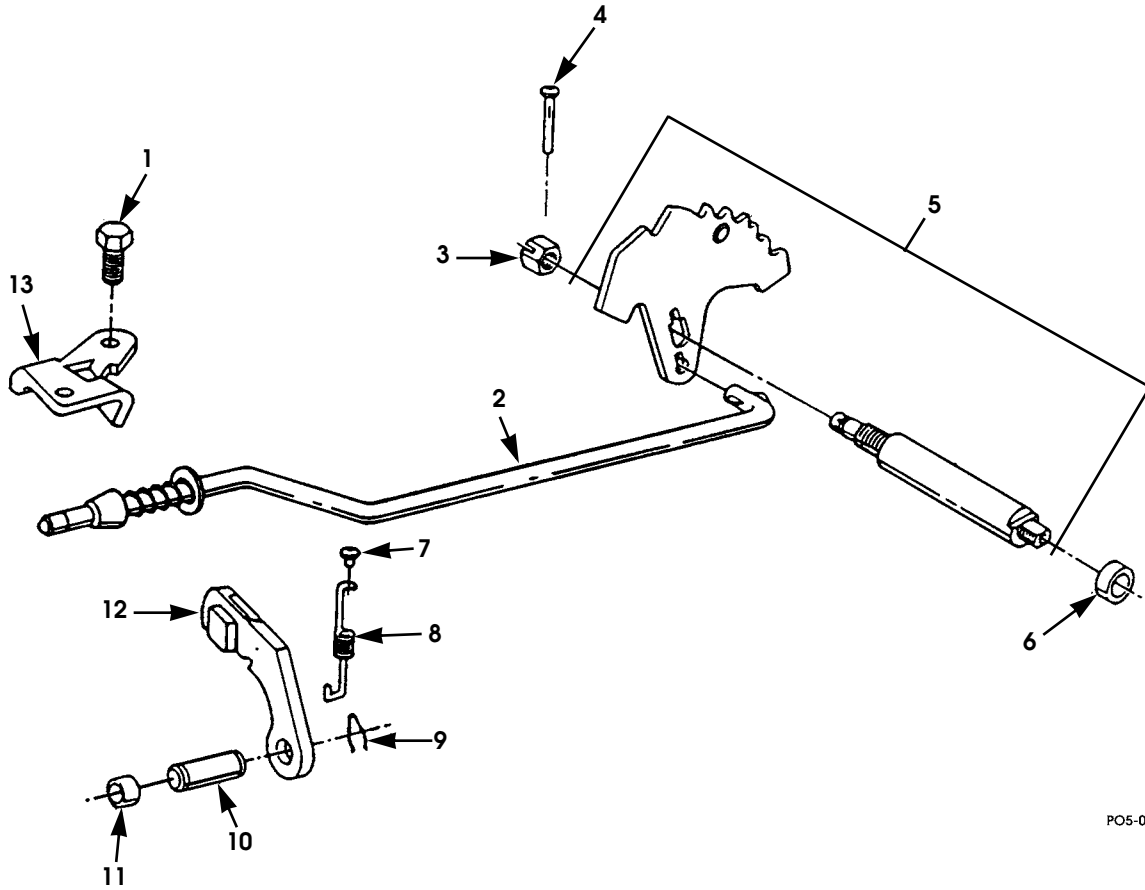

PO5-019

Figure 5-8. Transmission Parking Lock System.

# 2001 HUMMER PARTS CATALOG

## TRANSMISSION/TRANSFER CASE 5-19

ITEM	PART NUMBER	DESCRIPTION	QTY
		<b>Figure 5-8. Transmission Parking Lock System.</b>	
1	N/S	BOLT, M8 x 1.25 x 20, class 9.8 . . . . .	2
2	5744105	ACTUATOR ASSEMBLY . . . . .	1
3	5744076	NUT, hex . . . . .	1
4	5744122	PIN . . . . .	1
5	5714375	LEVER AND SHAFT ASSEMBLY . . . . .	1
6	5740322	SEAL ASSEMBLY . . . . .	1
7	5744111	STUD . . . . .	1
8	5744108	SPRING, retaining . . . . .	1
9	148148	RETAINER, spring type . . . . .	1
10	5742593	SHAFT, lock . . . . .	1
11	5742589	PLUG, expansion . . . . .	1
12	5714321	PAWL, parking lock . . . . .	1
13	5744103	BRACKET, parking lock . . . . .	1

# 2001 HUMMER PARTS CATALOG

## 5-20 TRANSMISSION/TRANSFER CASE

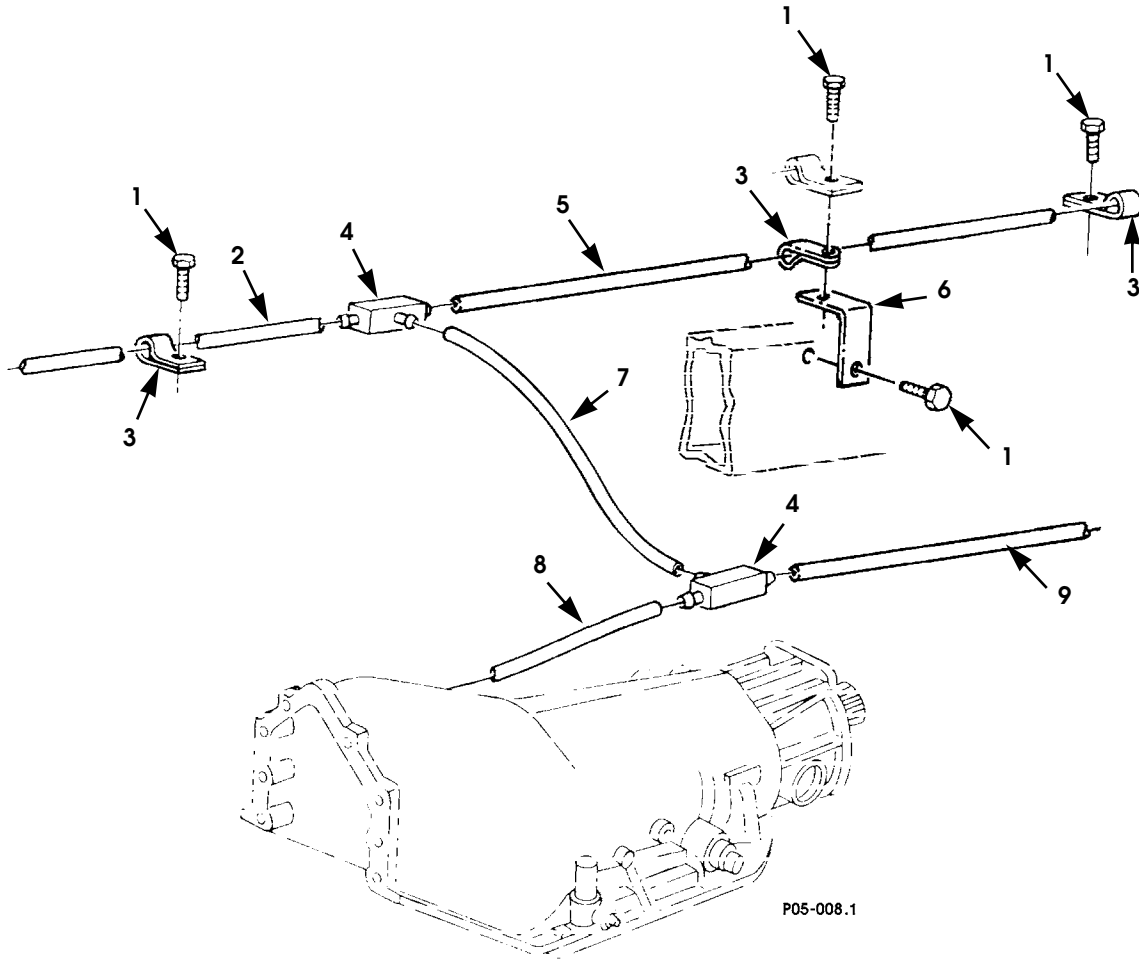

Figure 5-9. Transmission Vent Lines and Attaching Hardware.

# 2001 HUMMER PARTS CATALOG

## TRANSMISSION/TRANSFER CASE 5-21

ITEM	PART NUMBER	DESCRIPTION	QTY
		<b>Figure 5-9. Transmission Vent Lines and Attaching Hardware.</b>	
1	N/S	SCREW, tapping, 3/8 - 16 x 5/8, ZN .....	4
2	N/S	VENT LINE TUBE, 41-inch, SEE NOTE 1 .....	1
3	N/S	CLAMP, transmission vent line, cushioned, 1/4" .....	3
4	12339973-1	TEE, transmission vent line, union .....	2
5	N/S	VENT LINE TUBE, 64-inch, SEE NOTE 1 .....	1
6	12338663	BRACKET, vent line tube mounting .....	1
7	N/S	VENT LINE TUBE, 11-inch, SEE NOTE 1 .....	1
8	N/S	VENT LINE TUBE, 11-inch, SEE NOTE 1 .....	1
9	N/S	VENT LINE TUBE, 17-inch, SEE NOTE 1 .....	1
		NOTE 1: MAKE FROM BULK NYLON TUBE P/N 05741079 3/16" X 250' ROLL	



# 2001 HUMMER PARTS CATALOG

## 5-22 TRANSMISSION/TRANSFER CASE

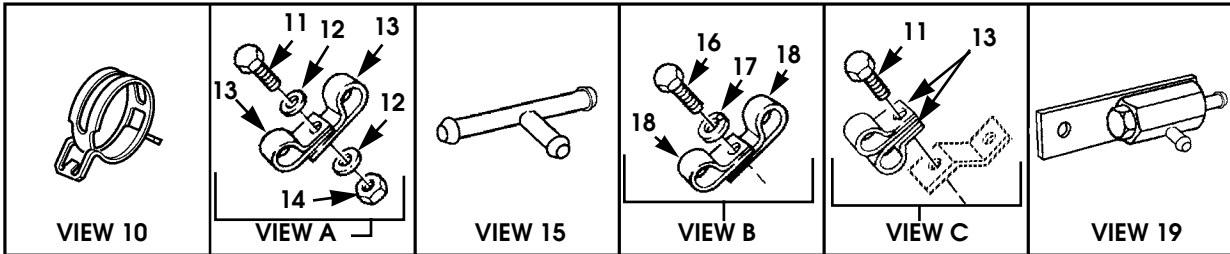
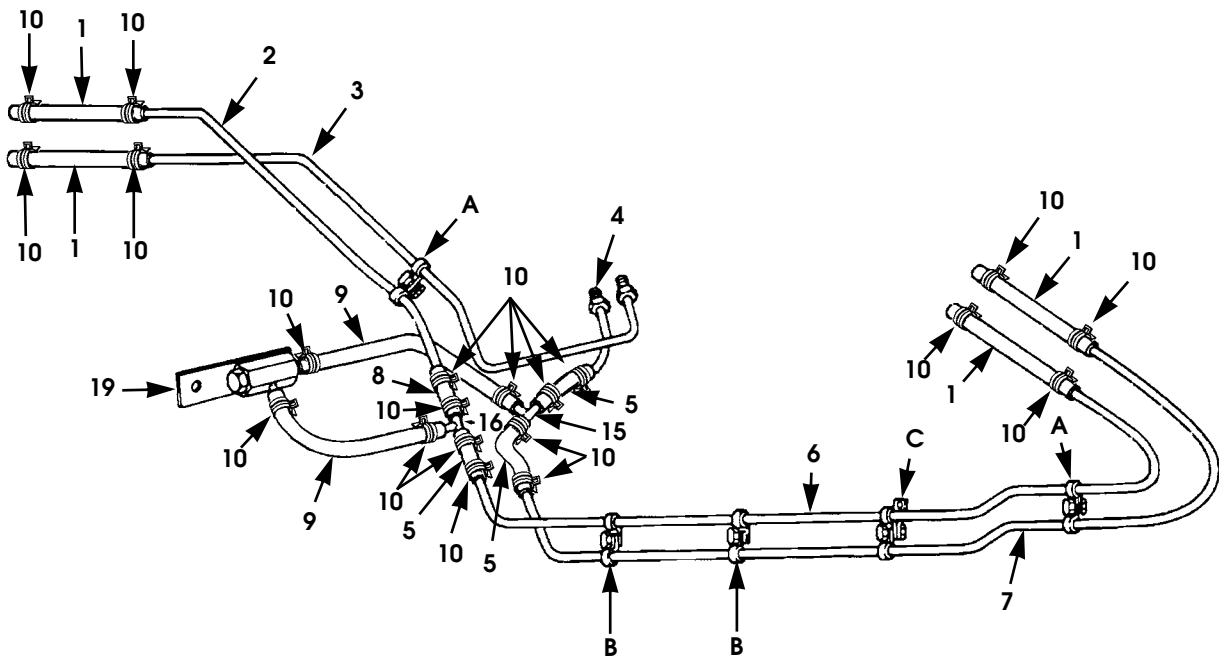

P05-009

Figure 5-10. Transmission/Transfer Case Cooling Lines.

# 2001 HUMMER PARTS CATALOG

## TRANSMISSION/TRANSFER CASE 5-23

ITEM	PART NUMBER	DESCRIPTION	QTY
		<b>Figure 5-10.</b> <b>Transmission/Transfer Case Cooling Lines.</b>	
1	N/S	HOSE, 3-inch, cooling lines, SEE NOTE 1 . . . . .	4
2	12338333	TUBE, transfer case to cooler, rear . . . . .	1
3	6008598	TUBE, transfer case to transmission . . . . .	1
4	6008597	TUBE, transmission to cooler, rear . . . . .	1
5	N/S	HOSE, 4-inch, transmission line to cooling line, SEE NOTE 1 . . . . .	3
6	12338335	TUBE, transmission to cooler, front . . . . .	1
7	12338332	TUBE, transfer case to cooler, front. . . . .	1
8	N/S	HOSE, 4-inch, transfer case line to cooling line, SEE NOTE 1 . . . . .	1
9	N/S	HOSE, 10-inch, tee-to-bypass valve, NOTE 1 . . . . .	2
10	6008528	CLAMP, cooling lines, hose, . . . . .	20
11	N/S	BOLT, flanged, 1/4 - 20 x 3/4, Gr5, CAD, cooling line clamps . . . . .	2
12	N/S	WASHER, flat, 1/4, CAD . . . . .	4
13	N/S	CLAMP, loop, cooling lines, 3/8" , cushioned. . . . .	4
14	N/S	LOCKNUT, 1/4 - 20, Gr8, cooling line clamps. . . . .	2
15	12447077	TEE, bypass valve . . . . .	2
16	N/S	SCREW, tapping, 3/8 - 16 x 3/4, ZN, cooling line clamps	2
17	N/S	LOCKWASHER, med, 3/8, ZN, cooling line clamps. . . .	2
18	N/S	CLAMP, cushioned, 3/8", cooling lines . . . . .	4
19	12447076	VALVE, bypass, transmission oil . . . . .	1
		NOTE 1: MAKE FROM BULK HOSE P/N 5741209, 3/8" X 25' ROLL	

# 2001 HUMMER PARTS CATALOG

## 5-24 TRANSMISSION/TRANSFER CASE

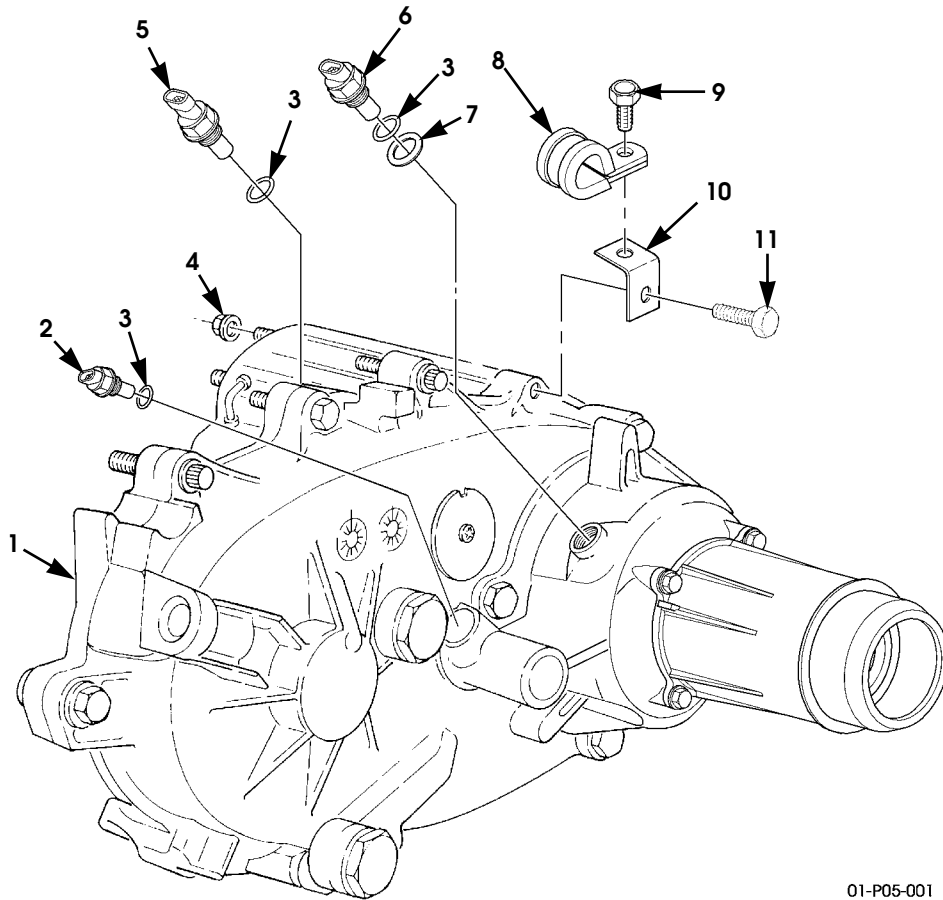

01-P05-001

Figure 5-11. Transfer Case Assembly.

# 2001 HUMMER PARTS CATALOG

## TRANSMISSION/TRANSFER CASE 5-25

ITEM	PART NUMBER	DESCRIPTION	QTY
		<b>Figure 5-11.</b> <b>Transfer Case Assembly.</b>	
1	6011651	TRANSFER CASE ASSEMBLY . . . . .	1
1	5745077	TRANSFER CASE ASSEMBLY, remanufactured . . . . .	1
2	5938686	SWITCH, transfer indicator, 12-volt . . . . .	1
3	5938616	SEAL, O-ring . . . . .	1
4	N/S	LOCKNUT, flanged, p.t., 3/8 - 24, transfer case . . . . .	6
5	5743511	SWITCH, transfer case range . . . . .	1
6	5743510	SWITCH, speed sensor . . . . .	1
7	5745239	SHIM, speed sensor . . . . .	A/R
8	N/S	P-CLAMP, cushioned, 7/16" . . . . .	1
9	N/S	SCREW, tapping, 3/8-16 x 3/4 . . . . .	1
10	5589115	BRACKET, transfer case . . . . .	1
11	N/S	SCREW, M10 - 1.5 x 27, class 9.8, T-case housing. . . . .	1

# 2001 HUMMER PARTS CATALOG

## 5-26 TRANSMISSION/TRANSFER CASE

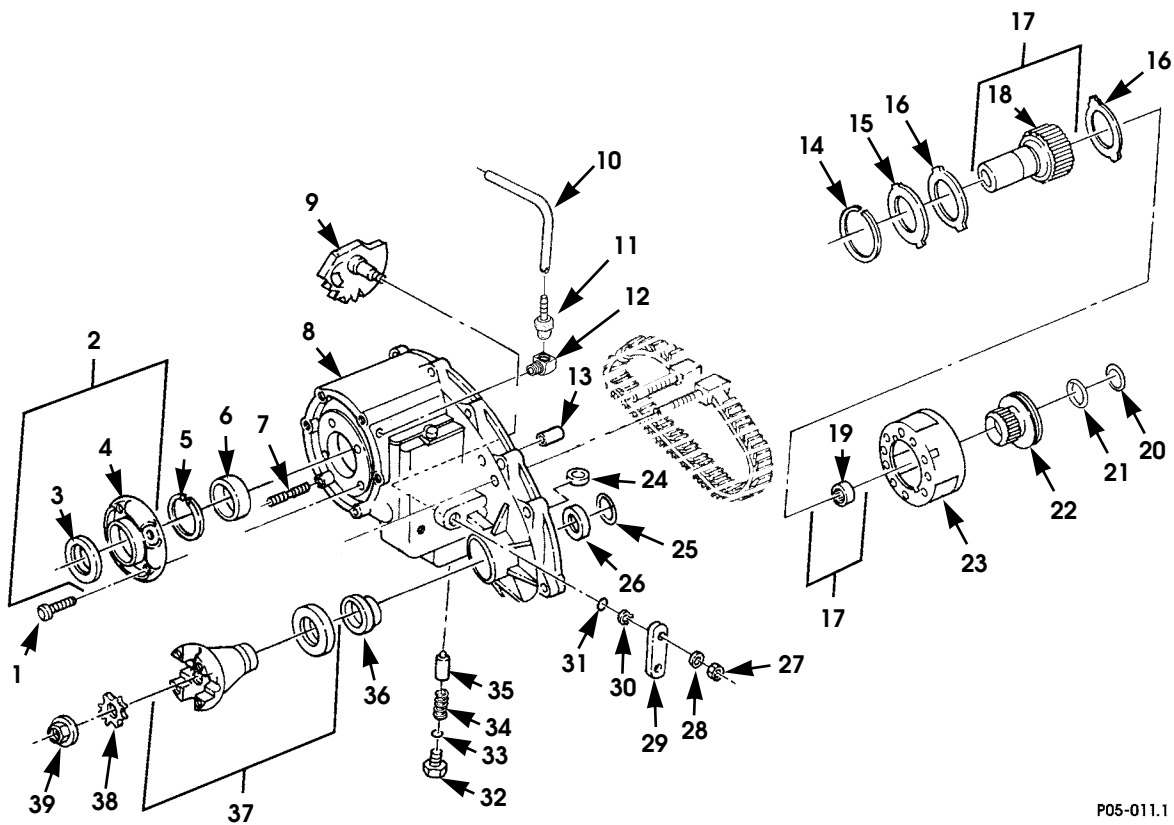

P05-011.1

Figure 5-12. Transfer Case Assembly, Front Half.

# 2001 HUMMER PARTS CATALOG

## TRANSMISSION/TRANSFER CASE 5-27

ITEM	PART NUMBER	DESCRIPTION	QTY
		<b>Figure 5-12.</b> <b>Transfer Case Assembly, Front Half.</b>	
1	5938626	RETAINER SCREW, input gear . . . . .	4
2	5938625	RETAINER ASSEMBLY, input gear . . . . .	1
3	5740017	•OIL SEAL, input gear . . . . .	1
4	N/S	•RETAINER, input gear. . . . .	1
5	5938623	LOCKRING, input gear, ring, retaining . . . . .	1
6	5714223	BEARING, transfer case . . . . .	1
7	5740008	STUD, mounting, transfer case . . . . .	6
8	5744429	TRANSFER CASE, front half . . . . .	1
9	5743744	SECTOR, transfer case . . . . .	1
10	N/S	TUBING, 17" SEE NOTE 1 . . . . .	1
11	12339978	CONNECTOR, male . . . . .	1
12	5937392	ELBOW, 90 degree, female . . . . .	1
13	5938610	BUSHING, rail. . . . .	1
14	5938622	LOCKRING, input gear . . . . .	1
15	5938624	RETAINING RING, input gear. . . . .	1
16	5715449	WASHER, thrust, input gear . . . . .	2
17	5714226	INPUT GEAR ASSEMBLY . . . . .	1
18	N/S	•GEAR, input . . . . .	1
19	5938621	•BEARING, input gear . . . . .	1
20	5938658	WASHER, transfer case, clutch shaft . . . . .	1
21	5938659	RETAINING RING, transfer case . . . . .	1
22	5714229	SLEEVE, transfer case, range. . . . .	1
23	5714225	PLANETARY ASSEMBLY . . . . .	1
24	5740513	MAGNETIC CHIP COLLECTOR . . . . .	1
25	5938608	RETAINING RING . . . . .	1
26	5938607	BEARING, front output. . . . .	1
27	5741254	NUT, operating lever, selector level . . . . .	1
28	N/S	WASHER, flat, hard, 3/8, type B, ZN, operating lever . . . . .	1
29	5938683	OPERATING LEVER, transfer case . . . . .	1
30	5740107	RETAINER, operating lever . . . . .	1
31	5740012	SEAL, operating lever . . . . .	1
32	5714808	SCREW, poppet spring . . . . .	1
33	5938616	SEAL, poppet spring . . . . .	1
34	5938615	POPPET SPRING . . . . .	1
35	5938614	PLUNGER, transfer case . . . . .	1
36	5744909	OIL SEAL, front output . . . . .	1
37	5744928	YOKE AND SLINGER, front output. . . . .	1
38	5740010	WASHER, yoke and slinger . . . . .	1
39	5740011	NUT, yoke and slinger . . . . .	1
		NOTE 1: MAKE FROM BULK NYLON TUBE P/N 5741079, 3/16" I.D. X 250'	

# 2001 HUMMER PARTS CATALOG

## 5-28 TRANSMISSION/TRANSFER CASE

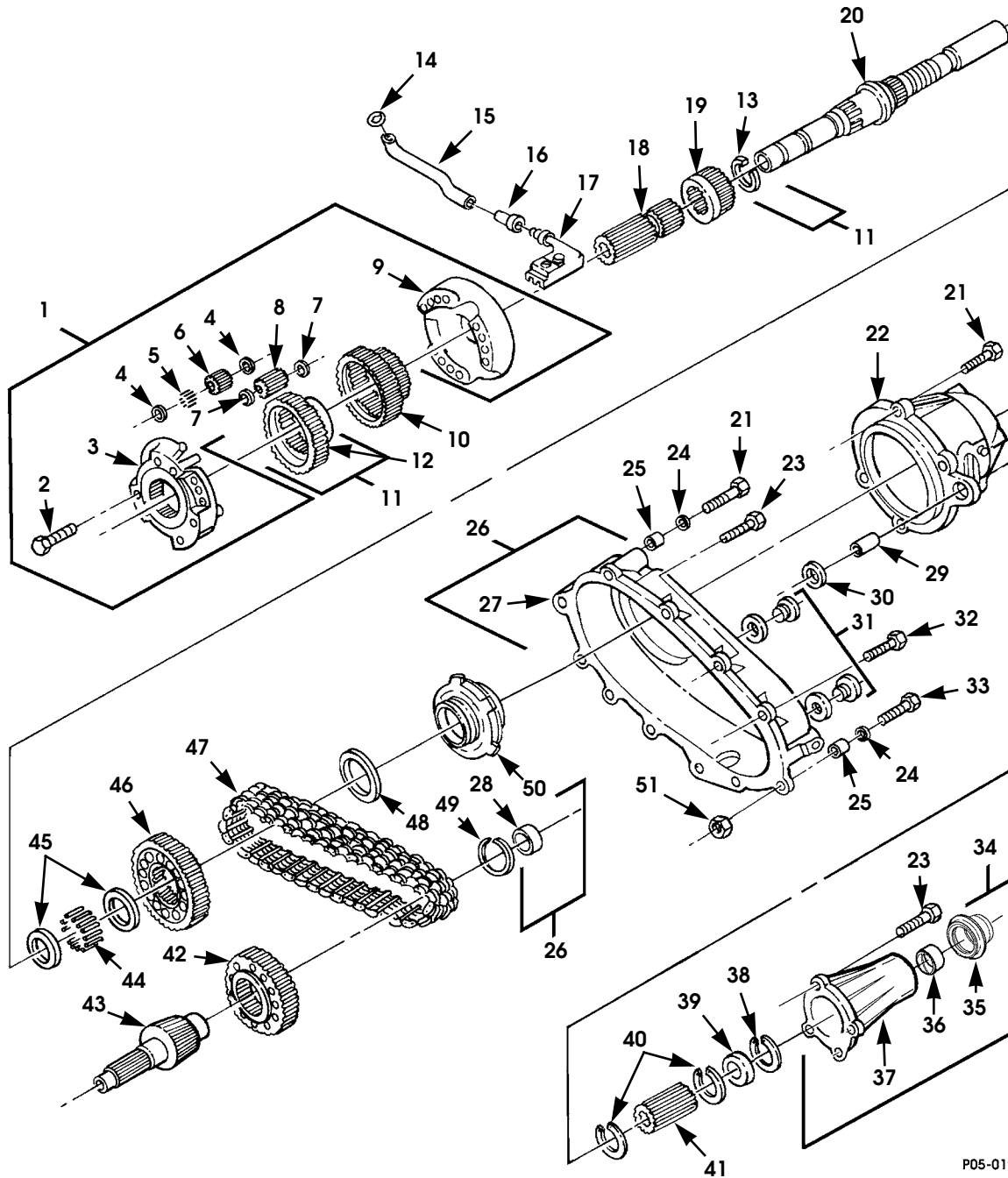

P05-012.1

Figure 5-13. Transfer Case Assembly, Rear Half.

# 2001 HUMMER PARTS CATALOG

## TRANSMISSION/TRANSFER CASE 5-29

ITEM	PART NUMBER	DESCRIPTION	QTY
		<b>Figure 5-13.</b> <b>Transfer Case Assembly, Rear Half.</b>	
1	5715448	DIFFERENTIAL CARRIER ASSEMBLY .....	1
2	5938641	•SCREW, differential carrier .....	6
3	5743072	•CARRIER, front differential. ....	1
4	5938646	•WASHER, thrust .....	6
5	5938645	•NEEDLE BEARING .....	54
6	5744880	•PINION, narrow .....	3
7	5938647	•WASHER, thrust, pinion. ....	6
8	5938643	•PINION, wide .....	3
9	S.I.A.	•CARRIER, rear differential (comes with Item 3) .....	1
10	5938650	GEAR, sprocket carrier .....	1
11	5938655	GEAR assembly differential .....	1
12	N/S	•GEAR, differential .....	1
13	5938656	•RING, differential gear .....	1
14	5938669	O-RING, oil tube .....	1
15	5938668	OIL TUBE .....	1
16	5938667	CONNECTOR, transfer case .....	1
17	5938666	SCREEN, oil tube .....	1
18	5714228	SHAFT, intermediate clutch .....	1
19	5938660	SLEEVE, mode shift .....	1
20	5714291	MAIN SHAFT .....	1
21	5938670	SCREW, rear bearing retainer .....	6
22	5743747	RETAINER, rear bearing .....	1
23	5740508	BOLT, case, rear half .....	10
24	5740230	WASHER, flat .....	12
25	5740102	PIN, case alignment .....	2
26	5939258	CASE ASSEMBLY, rear half .....	1
27	N/S	•CASE, rear half .....	1
28	5740015	•BEARING, front output .....	1
29	5938665	DOWEL, alignment .....	1
30	5938610	BUSHING, rail .....	1
31	5740224	PLUG, transfer case drain .....	2
32	5741075	SCREW, case halves .....	2
33	5743855	SCREW, transfer case, flanged .....	1
34	5714232	EXTENSION ASSEMBLY .....	1
35	5743751	•SEAL, rear output .....	1
36	5743750	•BUSHING, extension .....	1
37	N/S	•EXTENSION, rear housing .....	1
38	5745110	RETAINING RING .....	1
39	5938607	BEARING, rear output .....	1



# 2001 HUMMER PARTS CATALOG

## 5-30 TRANSMISSION/TRANSFER CASE

ITEM	PART NUMBER	DESCRIPTION	QTY
		<b>Figure 5-13.</b> <b>Transfer Case Assembly, Rear Half. (Cont'd)</b>	
40	5938673	RETAINING RING . . . . .	2
41	5743512	STONE WHEEL . . . . .	1
42	5938663	SPROCKET, drive . . . . .	1
43	5938662	SHAFT, front output . . . . .	1
44	5938654	BEARING, needle rollers . . . . .	53
45	5938653	SPACER, roller . . . . .	2
46	5938651	SPROCKET, drive . . . . .	1
47	5938664	CHAIN, drive . . . . .	1
48	5938652	RETAINING RING, sprocket . . . . .	1
49	5740101	RETAINING RING, sprocket . . . . .	1
50	5938674	PUMP ASSEMBLY, gear rotor . . . . .	1
51	11501033	LOCKNUT, p.t., transfer case guide cable . . . . .	1

**2001 HUMMER PARTS CATALOG**

**TRANSMISSION/TRANSFER CASE 5-31**

# 2001 HUMMER PARTS CATALOG

## 5-32 TRANSMISSION/TRANSFER CASE

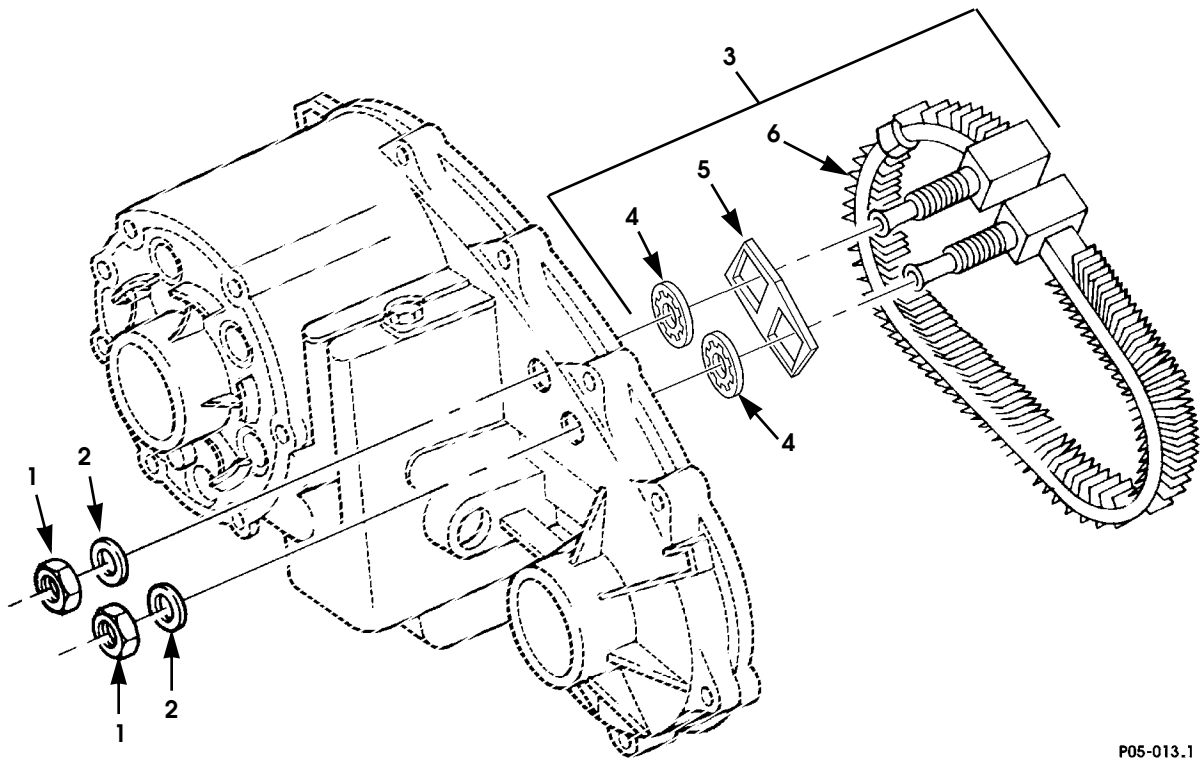

P05-013.1

Figure 5-14. Transfer Case Oil Cooler Assembly

# 2001 HUMMER PARTS CATALOG

## TRANSMISSION/TRANSFER CASE 5-33

ITEM	PART NUMBER	DESCRIPTION	QTY
		<b>Figure 5-14.</b> <b>Transfer Case Oil Cooler Assembly</b>	
1	N/S	NUT, slotted, 1/2 - 20, Gr5, ZN, oil cooler . . . . .	2
2	5741061	WASHER, oil cooler. . . . .	2
3	6011652	COOLER CORE ASSEMBLY, oil, transfer case . . . . .	1
4	5741062	•PACKING, preformed, oil cooler. . . . .	2
5	5745215	•BRACKET, T-case cooler support . . . . .	1
6	N/S	•COOLER CORE, oil, transfer case. . . . .	1

# 2001 HUMMER PARTS CATALOG

## 5-34 TRANSMISSION/TRANSFER CASE

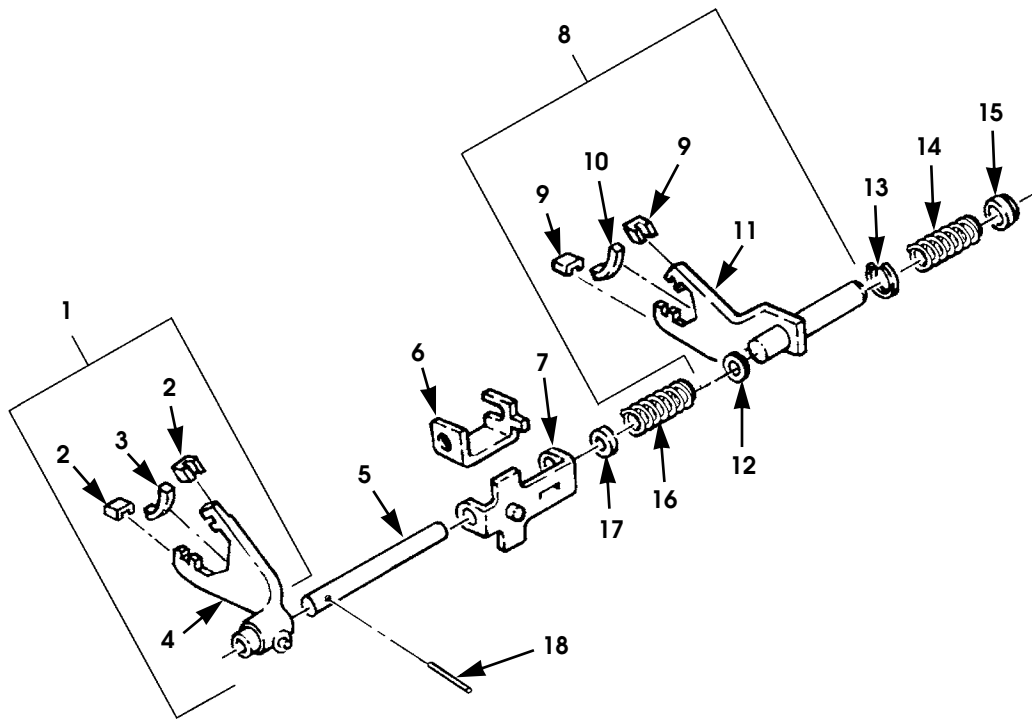

P05-014

Figure 5-15. Transfer Case Shift Mechanisms.

# 2001 HUMMER PARTS CATALOG

## TRANSMISSION/TRANSFER CASE 5-35

ITEM	PART NUMBER	DESCRIPTION	QTY
		<b>Figure 5-15.</b> <b>Transfer Case Shift Mechanisms.</b>	
1	5938627	SHIFTER FORK, transfer case . . . . .	1
2	5740114	•PAD, shifter fork . . . . .	2
3	5740223	•PAD, shifter fork . . . . .	1
4	S.I.A.	•SHIFTER FORK . . . . .	1
5	5938648	RAIL, transfer shift . . . . .	1
6	5938635	BRACKET, inner . . . . .	1
7	5938636	BRACKET, outer . . . . .	1
8	5714227	FORK ASSEMBLY, mode . . . . .	1
9	5740114	•PAD, shifter fork . . . . .	2
10	5938631	•PAD, shifter fork . . . . .	1
11	5939261	•SHIFTER FORK, front mode . . . . .	1
12	5938630	•BUSHING, transfer shift . . . . .	2
13	5938632	WASHER, thrust, spring, transfer shift . . . . .	1
14	5938633	SPRING, transfer shift . . . . .	1
15	5938634	BUSHING, transfer shift . . . . .	1
16	5938638	SPRING, transfer . . . . .	1
17	5938637	CUP, transfer shift . . . . .	1
18	5938649	PIN, fork to rail . . . . .	1

# 2001 HUMMER PARTS CATALOG

## 5-36 TRANSMISSION/TRANSFER CASE

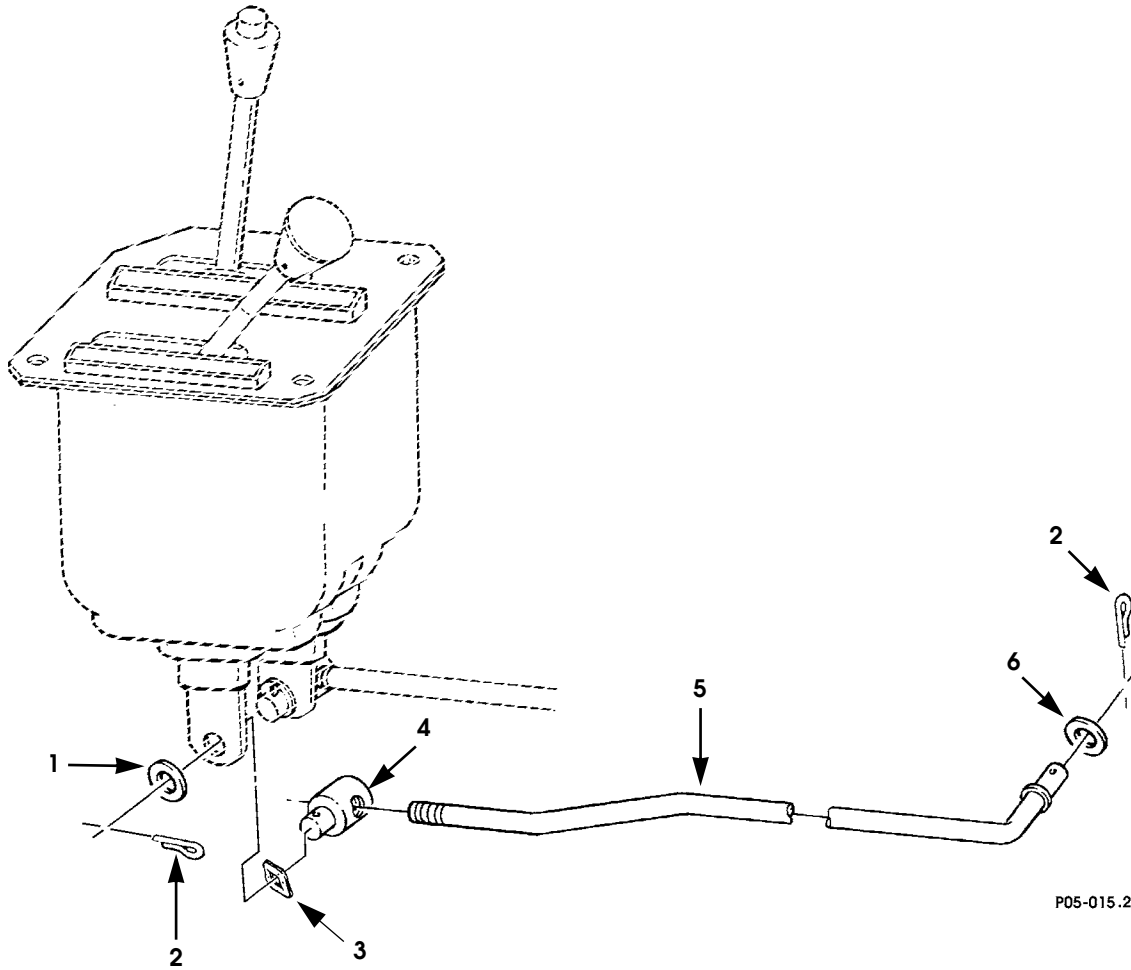

Figure 5-16. Transfer Case Shift Controls.

# 2001 HUMMER PARTS CATALOG

## TRANSMISSION/TRANSFER CASE 5-37

ITEM	PART NUMBER	DESCRIPTION	QTY
		<b>Figure 5-16.</b> <b>Transfer Case Shift Controls.</b>	
1	N/S	WASHER, flat, 3/8, CAD . . . . .	1
2	N/S	COTTER PIN, 1.8" x 3/4". . . . .	2
3	12340257-3	WASHER, wave. . . . .	1
4	12338442-2	TRUNNION, shift converter . . . . .	1
5	12460067	ROD, shift linkage. . . . .	1
6	N/S	WASHER, flat, 3/8, type B . . . . .	1



# 2001 HUMMER PARTS CATALOG

## 5-38 TRANSMISSION/TRANSFER CASE

# 2001 HUMMER PARTS CATALOG

## WHEELS AND TIRES/CENTRAL TIRE INFLATION SYSTEM 6-1

### Section 6

## WHEELS AND TIRES/CENTRAL TIRE INFLATION SYSTEM

TITLE	PAGE NUMBER
Central Tire Inflation System Routing . . . . .	6-14
CTIS Control Panel and Electrical Harnesses . . . . .	6-8
CTIS Valve Assembly and Compressor . . . . .	6-10
Wheel, Tire and Runflat Assembly, 17", One-Piece Aluminum (Optional) . . . . .	6-6
Wheel, Tire, and Beadlock Assembly, Two-Piece Rim . . . . .	6-4
Wheel, Tire, and Runflat Assembly, Two-Piece Rim . . . . .	6-2

# 2001 HUMMER PARTS CATALOG

## 6-2 WHEELS AND TIRES/CENTRAL TIRE INFLATION SYSTEM

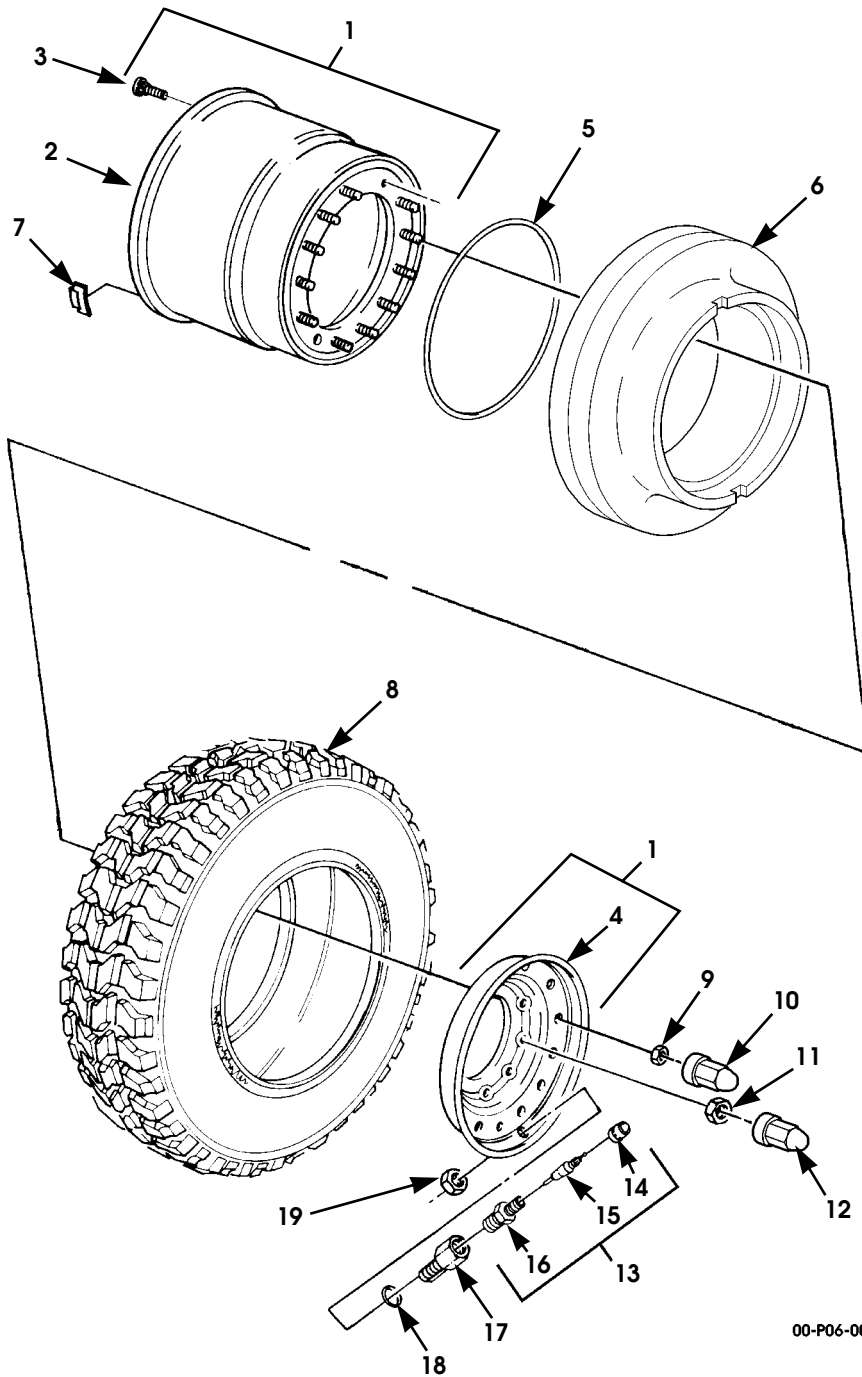

Figure 6-1. Wheel, Tire, and Runflat Assembly, Two-Piece Rim.

# 2001 HUMMER PARTS CATALOG

## WHEELS AND TIRES/CENTRAL TIRE INFLATION SYSTEM 6-3

ITEM	PART NUMBER	DESCRIPTION	QTY
		<b>Figure 6-1. Wheel, Tire, and Runflat Assembly, Two-Piece Rim.</b>	
1	5745404	WHEEL ASSEMBLY, two-piece steel, inner rim and outer rims and bolt assembly . . . . .	4
2	S.I.A.	•RIM, inner, two-piece steel wheel . . . . .	4
3	EC12460179	•BOLT . . . . .	48
4	S.I.A.	•RIM, outer, two-piece steel wheel . . . . .	4
5	RCSK17877	O-RING . . . . .	4
6	6004835	RUNFLAT, low profile . . . . .	4
7	5744406	WHEEL WEIGHTS, pack of 10, 1 oz., clip-on . . . . .	4
7	5744407	WHEEL WEIGHTS, pack of 10, 2 oz., clip-on . . . . .	4
7	5744408	WHEEL WEIGHTS, pack of 10, 4 oz., clip-on . . . . .	4
7	5744409	WHEEL WEIGHTS, pack of 10, 6 oz., clip-on . . . . .	4
7	5593926	WHEEL WEIGHTS, set of 12, adhesive . . . . .	4
8	6002923	TIRE, Wrangler GSA . . . . .	4
8	12342644	TIRE, Radial MT . . . . .	4
9	EC12339501	NUT, flanged, 1/2 - 20. . . . .	48
10	6011148	WHEEL NUT COVER . . . . .	48
11	EC12339403	LUG NUT . . . . .	32
12	6011148	LUG NUT COVER . . . . .	32
13	12342634	TANK VALVE ASSEMBLY . . . . .	4
14	S.I.A.	•VALVE CAP . . . . .	4
15	S.I.A.	•CORE . . . . .	4
16	S.I.A.	•TANK VALVE . . . . .	4
17	EC12342793	INSERT, valve hole . . . . .	4
18	12342794	O-RING . . . . .	4
19	MS21245-8	NUT, 1/2 - 20 . . . . .	4
	5743721	LUBRICANT, runflat, 11 oz. tube, case of 10 (not illustrated)	1
	6009517	DECAL, runflat (not illustrated) . . . . .	1

# 2001 HUMMER PARTS CATALOG

## 6-4 WHEELS AND TIRES/CENTRAL TIRE INFLATION SYSTEM

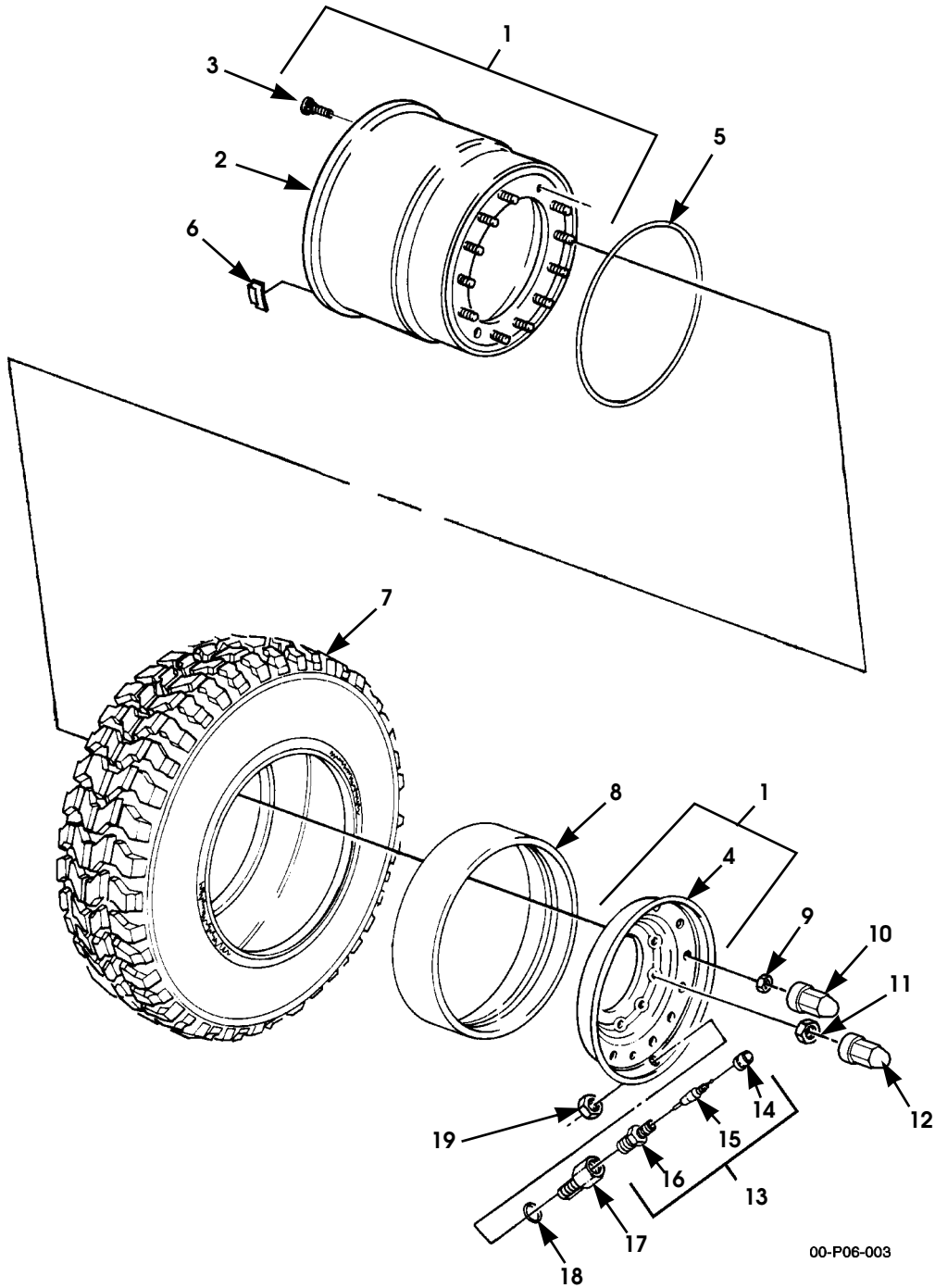

00-P06-003

Figure 6-2. Wheel, Tire, and Beadlock Assembly, Two-Piece Rim.

# 2001 HUMMER PARTS CATALOG

## WHEELS AND TIRES/CENTRAL TIRE INFLATION SYSTEM 6-5

ITEM	PART NUMBER	DESCRIPTION	QTY
		<b>Figure 6-2. Wheel, Tire, and Beadlock Assembly, Two-Piece Rim.</b>	
1	5745404	WHEEL ASSEMBLY, two-piece steel, inner rim and outer rims and bolt assembly . . . . .	4
2	S.I.A.	•RIM, inner, two-piece steel wheel . . . . .	4
3	EC12460179	•BOLT . . . . .	48
4	S.I.A.	•RIM, outer, two-piece steel wheel . . . . .	4
5	RCSK17877	O-RING . . . . .	4
6	5744406	WHEEL WEIGHTS, pack of 10, 1 oz, clip-on. . . . .	4
6	5744407	WHEEL WEIGHTS, pack of 10, 2 oz, clip-on. . . . .	4
6	5744408	WHEEL WEIGHTS, pack of 10, 4 oz, clip-on. . . . .	4
6	5744409	WHEEL WEIGHTS, pack of 10, 6 oz, clip-on. . . . .	4
6	5593926	WHEEL WEIGHTS, set of 12, adhesive . . . . .	4
7	6002923	TIRE, Wrangler GSA . . . . .	4
7	12342644	TIRE, Radial MT . . . . .	4
8	5594465	BEADLOCK . . . . .	4
9	EC12339501	NUT, flanged, 1/2 - 20. . . . .	48
10	6011148	WHEEL NUT COVER . . . . .	48
11	EC12339403	LUG NUT . . . . .	32
12	6011148	LUG NUT COVER . . . . .	32
13	12342634	TANK VALVE ASSEMBLY . . . . .	4
14	N/S	•VALVE CAP . . . . .	4
15	N/S	•CORE . . . . .	4
16	N/S	•TANK VALVE . . . . .	4
17	EC12342793	INSERT, valve hole . . . . .	4
18	12342794	O-RING . . . . .	4
19	MS21245-8	NUT, 1/2 - 20 . . . . .	4
	6009518	DECAL, beadlock (not illustrated). . . . .	1

# 2001 HUMMER PARTS CATALOG

## 6-6 WHEELS AND TIRES/CENTRAL TIRE INFLATION SYSTEM

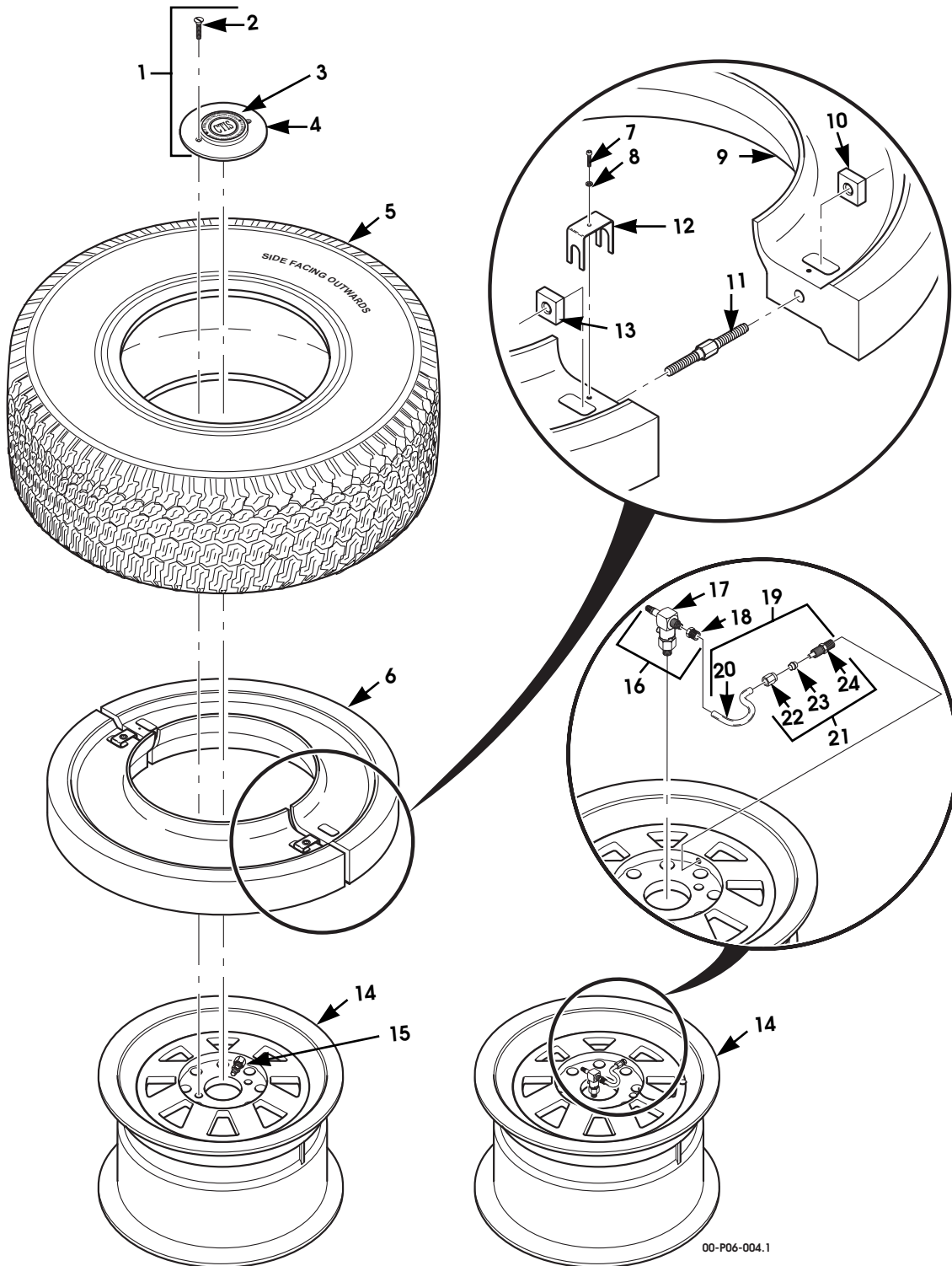

00-P06-004.1

Figure 6-3. Wheel, Tire and Runflat Assembly, 17", One-Piece Aluminum (Optional).

# 2001 HUMMER PARTS CATALOG

## WHEELS AND TIRES/CENTRAL TIRE INFLATION SYSTEM 6-7

ITEM	PART NUMBER	DESCRIPTION	QTY
		<b>Figure 6-3. Wheel, Tire and Runflat Assembly, 17", One-Piece Aluminum (Optional).</b>	
1	6011260	LUG COVER ASSEMBLY, with CTIS . . . . .	4
1	6011252	LUG COVER ASSEMBLY, w/o CTIS . . . . .	4
2	6011548	•SCREW, center cover, aluminum wheel . . . . .	8
3	6011281	•DISK, wheel lug cover, with CTIS. . . . .	4
3	6011282	•DISK, wheel lug cover, w/o CTIS. . . . .	4
4	6011280	•COVER, wheel lug . . . . .	4
5	6010977	TIRE, Wrangler, GSA, 37 x 12.50 R - 17 . . . . .	4
6	6011266	RUNFLAT ASSEMBLY, SEE NOTE 1 . . . . .	4
7	S.I.A.	•SCREW . . . . .	8
8	S.I.A.	•WASHER . . . . .	8
9	S.I.A.	•RUNFLAT HALF . . . . .	8
10	S.I.A.	•SQUARE NUT, RH Thread . . . . .	8
11	S.I.A.	•SCREW, N-12. . . . .	8
12	S.I.A.	•BRACKET, security . . . . .	8
13	S.I.A.	•SQUARE NUT, LH Thread . . . . .	8
14	6011533	WHEEL, one-piece aluminum, 17" . . . . .	4
15	6011283	TANK VALVE . . . . .	4
16	6005109	VALVE ASSEMBLY, quick disconnect. . . . .	4
17	S.I.A.	•VALVE BODY. . . . .	4
18	S.I.A.	•TUBE NUT. . . . .	4
19	5745243	CTIS WHEEL TUBE ASSEMBLY . . . . .	4
20	S.I.A.	•TUBE, wheel, CTIS . . . . .	4
21	S.I.A.	•FITTING ASSEMBLY, CTIS wheel tube . . . . .	4
22	S.I.A.	••TUBE NUT. . . . .	4
23	S.I.A.	••FERRULE . . . . .	4
24	S.I.A.	••CONNECTOR. . . . .	4
	5593926	WHEEL BALANCE WEIGHT, tape on (not illustrated). . .	A/R



# 2001 HUMMER PARTS CATALOG

## 6-8 WHEELS AND TIRES/CENTRAL TIRE INFLATION SYSTEM

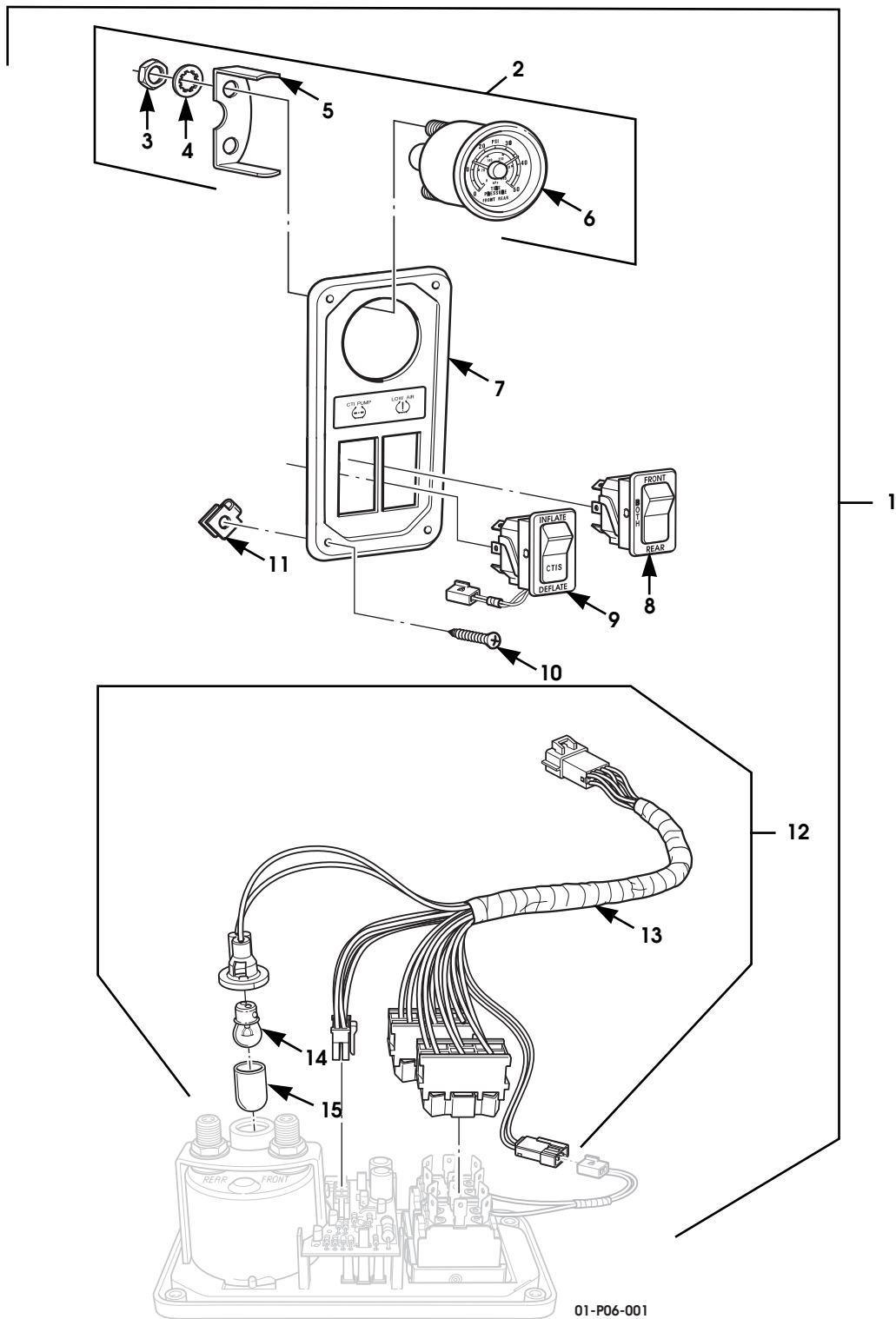

Figure 6-4. CTIS Control Panel and Electrical Harnesses.

# 2001 HUMMER PARTS CATALOG

## WHEELS AND TIRES/CENTRAL TIRE INFLATION SYSTEM 6-9

ITEM	PART NUMBER	DESCRIPTION	QTY
		<b>Figure 6-4. CTIS Control Panel and Electrical Harnesses.</b>	
1	6011764	MODULE and harness, CTIS . . . . .	1
2	5745388	•GAUGE ASSEMBLY, CTIS tire pressure . . . . .	1
3	S.I.A.	••NUT . . . . .	2
4	S.I.A.	••LOCKWASHER . . . . .	2
5	S.I.A.	••BRACKET, CTIS mounting. . . . .	1
6	S.I.A.	••GAUGE, CTIS tire pressure. . . . .	1
7	S.I.A.	•PANEL, CTIS. . . . .	1
8	6006604	•SWITCH, CTIS selector . . . . .	1
9	6006603	•SWITCH, CTIS INFLATE/DEFLATE . . . . .	1
10	5939651P2	•SCREW, CTIS gauge panel . . . . .	4
11	N/S	•SPEEDNUT, #10 . . . . .	4
12	6011637	•HARNESS ASSEMBLY, CTIS interior . . . . .	1
13	S.I.A.	••HARNESS, CTIS . . . . .	1
14	S.I.A.	••LAMP, trade, #1815. . . . .	1
15	S.I.A.	••LENS . . . . .	1

# 2001 HUMMER PARTS CATALOG

## 6-10 WHEELS AND TIRES/CENTRAL TIRE INFLATION SYSTEM

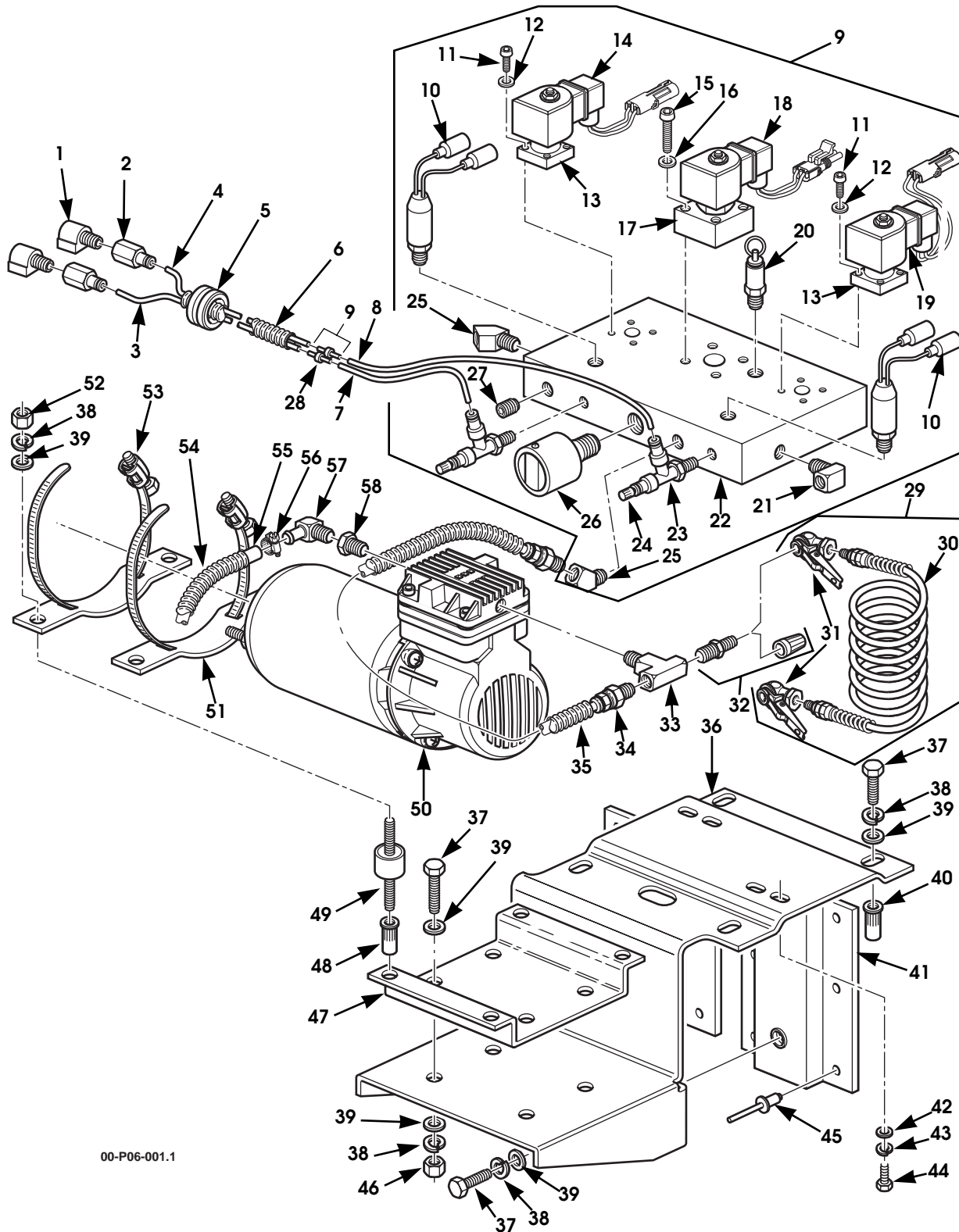

Figure 6-5. CTIS Valve Assembly and Compressor.

# 2001 HUMMER PARTS CATALOG

## WHEELS AND TIRES/CENTRAL TIRE INFLATION SYSTEM 6-11

ITEM	PART NUMBER	DESCRIPTION	QTY
		<b>Figure 6-5. CTIS Valve Assembly and Compressor.</b>	
1	5937392	ELBOW, street . . . . .	2
2	6009491	CONNECTOR, female, 1/8" . . . . .	2
3	N/S	TUBING, 1/8" O.D. x 24" long (rear) (SEE NOTE1) . . . . .	1
4	N/S	TUBING, 1/8" O.D. x 24" long, (front) (SEE NOTE1) . . . . .	1
5	6000042	GROMMET . . . . .	1
6	N/S	CONVOLUTED CONDUIT, non-slit, 3/8" O.D. x 1/4" I.D. x 6" long, CTI dash gauge lines . . . . .	1
7	N/S	TUBING, 1/8" O.D., 2" long (rear) (SEE NOTE 1) . . . . .	1
8	N/S	TUBING, 1/8" O.D., 4" long (front) (SEE NOTE1) . . . . .	1
9	6009994	MANIFOLD ASSY, CTIS . . . . .	1
10	6001036	•SWITCH, low pressure . . . . .	2
11	N/S	•SCREW, inflate valve . . . . .	8
12	N/S	•LOCKWASHER, #8 . . . . .	8
13	6008370	•VALVE, inflate . . . . .	2
14	6010116	•COIL ASSEMBLY, rear, inflate . . . . .	1
15	N/S	•SCREW, deflate valve . . . . .	4
16	N/S	•LOCKWASHER, 1/4. . . . .	4
17	6008371	•VALVE, deflate . . . . .	1
18	6010118	•COIL ASSEMBLY, deflate . . . . .	1
19	6010115	•COIL ASSEMBLY, front, inflate . . . . .	1
20	6008872	•VALVE, safety . . . . .	1
21	6008377	•STREET ELBOW, 90-degrees . . . . .	1
22	6008375	•MANIFOLD, CTI. . . . .	1
23	6008379	•TEE, swivel . . . . .	2
24	6008380	•TUBE PLUG . . . . .	2
25	44-130339B	•STREET ELBOW, 45-degrees . . . . .	2
26	5935430	•DUST EXCLUDER . . . . .	1
27	N/S	•PLUG, 1/4" FTP . . . . .	1
28	6007670	•ORIFICE, CTIS . . . . .	2
29	6004415	HOSE ASSEMBLY, CTIS auxiliary air . . . . .	1
30	6004416	•HOSE, auxiliary air . . . . .	1
31	5745424	•CHUCK, clip-on . . . . .	2
32	12342634	TANK VALVE ASSEMBLY . . . . .	1
33	44-4-130424B	STREET TEE . . . . .	1
34	6009996	HOSE, stainless steel braided, compressor-to-CTIS manifold, w/fittings . . . . .	1
35	N/S	CONVOLUTED CONDUIT, 16.5" long, slit, compressor-to-CTIS manifold, SEE NOTE 2 . . . . .	1
36	6010004B9	BRACKET ASSEMBLY, valve mounting . . . . .	1

# 2001 HUMMER PARTS CATALOG

## 6-12 WHEELS AND TIRES/CENTRAL TIRE INFLATION SYSTEM

ITEM	PART NUMBER	DESCRIPTION	QTY
		<b>Figure 6-5.</b> <b>CTIS Valve Assembly and Compressor. (Cont'd)</b>	
37	N/S	SCREW, 1/4 - 20 x 3/4 . . . . .	10
38	N/S	LOCKWASHER, split-ring, 1/4 . . . . .	10
39	N/S	WASHER, flat, 1/4 . . . . .	14
40	N/S	NUT INSERT, 1/4 - 20 . . . . .	4
41	6010094	BRACKET ASSEMBLY, compressor, side . . . . .	2
42	N/S	WASHER, flat, #10 . . . . .	4
43	N/S	LOCKWASHER, med, #10 . . . . .	4
44	N/S	SCREW, #10 - 24 x 1/2. . . . .	4
45	N/S	RIVET . . . . .	6
46	N/S	NUT, 1/4 - 20 . . . . .	4
47	6009998B9	BRACKET ASSEMBLY, compressor lower . . . . .	1
48	N/S	•NUT INSERT, 1/4 x 28 . . . . .	4
49	12338607	ISOLATOR . . . . .	4
50	5939999	COMPRESSOR, CTIS . . . . .	1
51	6003902B2	BRACKET, compressor upper . . . . .	2
52	N/S	NUT, 1/4 - 28, ZN . . . . .	4
53	11608950-18	CLAMP, hose . . . . .	2
54	N/S	CONVOLUTED CONDUIT, 21" long, non-slit air horn-to-compressor, SEE NOTE 3 . . . . .	1
55	6010341	HOSE, 21", air horn-to-compressor . . . . .	1
56	11608950-1	CLAMP, hose . . . . .	2
57	12339415	ELBOW, 90 degrees . . . . .	2
58	N/S	REDUCER, 3/8" NPT-to-1/4" NPT. . . . .	1
		NOTE 1: CUT FROM BULK TUBING P/N CPR104420-6, 1/ 8" OD X 50' LONG, BLACK	
		NOTE 2: CUT FROM SLIT CONVOLUTED CONDUIT, P/N 6007306, 7/8" O.D. X 3/4" I.D. X 20" LONG	
		NOTE 3: CUT FROM NON-SLIT CONVOLUTED CONDUIT, P/N 6007446, 7/8" O.D. X 3/4" I.D. X 38" LONG	



# 2001 HUMMER PARTS CATALOG

## 6-14 WHEELS AND TIRES/CENTRAL TIRE INFLATION SYSTEM

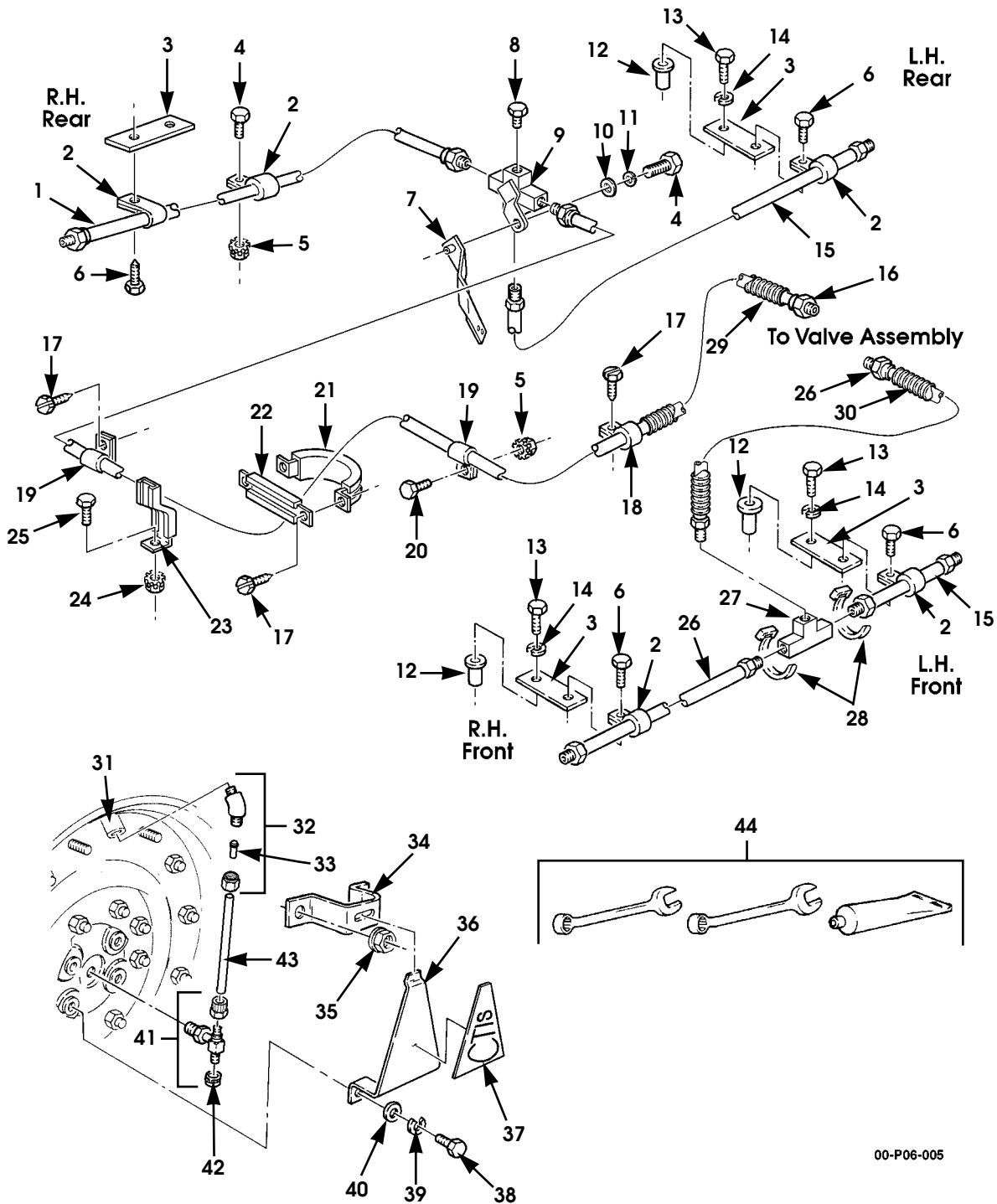

00-P06-005

Figure 6-6. Central Tire Inflation System Routing.

# 2001 HUMMER PARTS CATALOG

## WHEELS AND TIRES/CENTRAL TIRE INFLATION SYSTEM 6-15

ITEM	PART NUMBER	DESCRIPTION	QTY
		<b>Figure 6-6. Central Tire Inflation System Routing.</b>	
1	6005738	HOSE ASSEMBLY, rear tee-to-R.H. side . . . . .	1
2	MS21333-123	P-CLIP . . . . .	5
3	5594462	BRACKET, P-clip . . . . .	4
4	N/S	BOLT, 1/4 - 20 x 1, Gr8, CAD. . . . .	2
5	N/S	LOCKNUT, 1/4 - 20, Gr8 . . . . .	2
6	N/S	SCREW, tapping, 3/8 - 16 x 5/8 . . . . .	4
7	6007737	BRACKET, CTI. . . . .	1
8	127951	PLUG, hex hd . . . . .	1
9	11669082	CROSS AND STRAP ASSEMBLY . . . . .	1
10	N/S	WASHER, flat, 1/4 . . . . .	1
11	N/S	LOCKWASHER, 1/4. . . . .	1
12	12339998-12	PLUSNUT . . . . .	3
13	N/S	SCREW, 5/16 - 18 x 1, Gr8, CAD. . . . .	3
14	N/S	LOCKWASHER, med, 5/16, ZN . . . . .	3
15	6005739	HOSE ASSEMBLY, tee-to-L.H. side, front & rear . . . . .	2
16	6005737	HOSE ASSEMBLY, valve-to-rear tee. . . . .	1
17	N/S	SCREW, tapping, #10 - 32 x 1/2. . . . .	5
18	MS21333-77	P-CLIP . . . . .	2
19	MS21333-76	P-CLIP . . . . .	2
20	431942	SCREW . . . . .	1
21	12340665	CLAMP, strap. . . . .	1
22	N/S	•CROSSBAR, clamp. . . . .	1
23	12339339	STRAP, retaining . . . . .	4
24	N/S	NUT AND LOCKWASHER ASSEMBLY, 1/4 - 20 . . . . .	4
25	N/S	SCREW . . . . .	4
26	6005736	HOSE ASSEMBLY, valve-to-front tee, front tee-to-R.H. side . . . . .	2
27	44-4130438	TEE, female . . . . .	2
28	MS3367-3-0	TIE WRAP. . . . .	2
29	6007672	CONVOLUTED CONDUIT, slit, 19 1/2" long, manifold-to-rear tee . . . . .	1
30	6007672	CONVOLUTED CONDUIT, slit, 19 1/2" long, manifold-to-front tee . . . . .	2
31	12342793	INSERT, valve hole . . . . .	4
32	5593467	ELBOW ASSEMBLY, 45 degree male . . . . .	4
33	5598770	INSERT, nylon tubing. . . . .	1
34	5935449B5	BRACKET, wheel tube shield support. . . . .	1
35	EC12339501	NUT, flanged, 1/2 - 20 . . . . .	12
36	5935441B5	SHIELD, CTIS tube . . . . .	4
37	6011188	DECAL, 'CTIS' logo . . . . .	4
38	N/S	BOLT, 7/16 - 14 x 3/4 . . . . .	2



# 2001 HUMMER PARTS CATALOG

## 6-16 WHEELS AND TIRES/CENTRAL TIRE INFLATION SYSTEM

ITEM	PART NUMBER	DESCRIPTION	QTY
		<b>Figure 6-6.</b> <b>Central Tire Inflation System Routing.</b>	
39	N/S	LOCKWASHER, med, 7/16, ZN . . . . .	2
40	N/S	WASHER, flat, hardened, type B, 7/16, ZN. . . . .	2
41	6005109	VALVE ASSEMBLY, quick disconnect . . . . .	4
42	5594510	•CAP, valve . . . . .	4
43	NPN	HOSE, 5 1/4" long (SEE NOTE 1). . . . .	4
44	5743069	KIT, CTIS tools. . . . .	1
		 NOTE 1: CUT FROM BULK HOSE P/N CP R1044202	

# 2001 HUMMER PARTS CATALOG

**BRAKES 7-1**

## Section 7

### BRAKES

TITLE	PAGE NUMBER
ABS Electronic Control Unit (ECU) . . . . .	7-18
ABS Modulator . . . . .	7-12
ABS Wheel Speed Sensor . . . . .	7-16
Brake Lines . . . . .	7-14
Front Service Brake Caliper Assembly and Rotor . . . . .	7-8
Master Cylinder Assembly and Hydro-Boost Assembly . . . . .	7-10
Parking Brake Cables and Mounting Hardware . . . . .	7-4
Parking Brake Hand Lever and Rod . . . . .	7-2
Rear Service and Parking Brake Caliper Assembly and Rotor . . . . .	7-6
Service Brake Pedal Assembly . . . . .	7-20

# 2001 HUMMER PARTS CATALOG

## 7-2 BRAKES

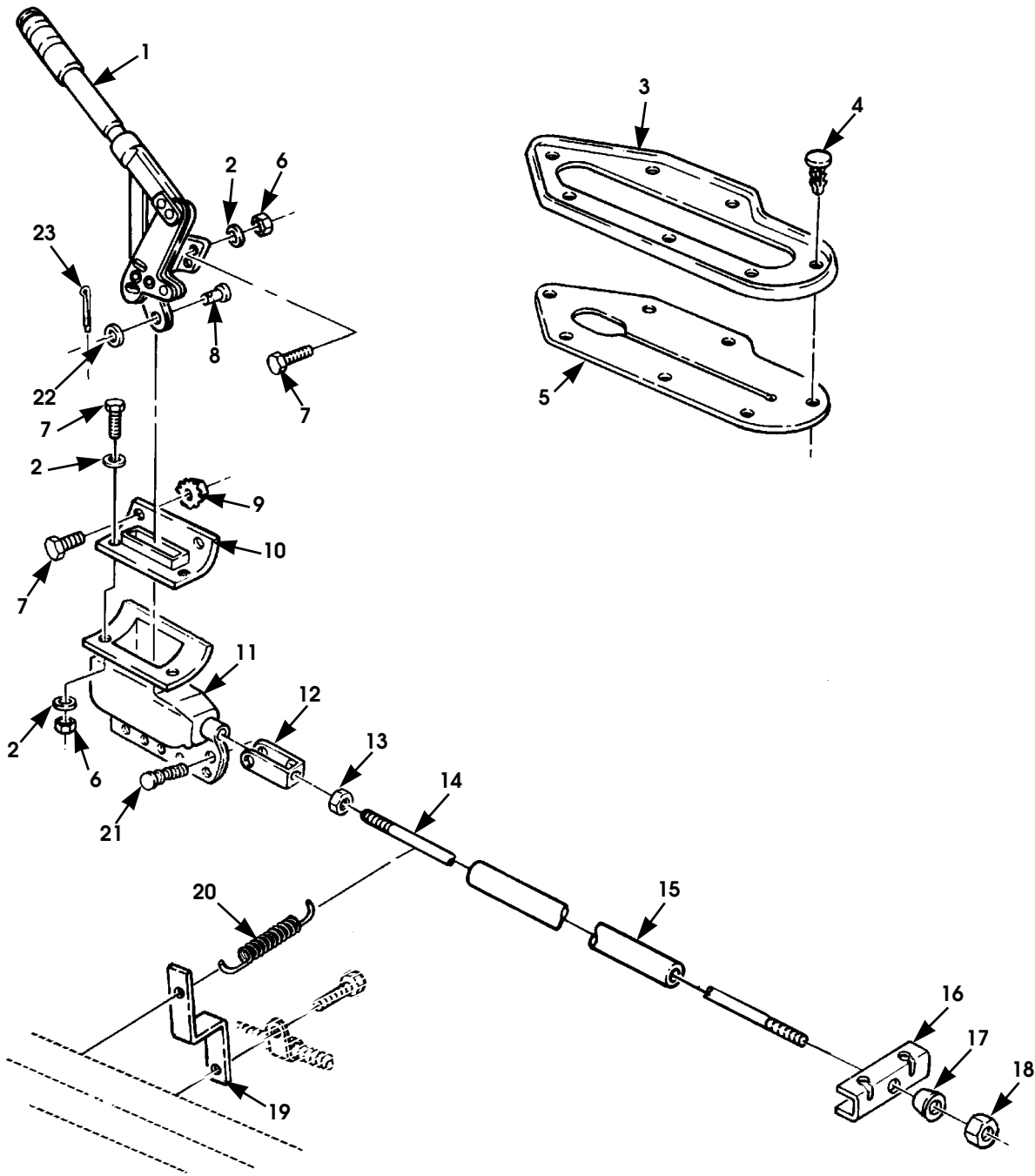

P07-001.

Figure 7-1. Parking Brake Hand Lever and Rod.

# 2001 HUMMER PARTS CATALOG

## BRAKES 7-3

ITEM	PART NUMBER	DESCRIPTION	QTY
		<b>Figure 7-1. Parking Brake Hand Lever and Rod.</b>	
1	WA12339218	LEVER, parking brake . . . . .	1
2	N/S	WASHER, flat, 1/4, parking brake lever. . . . .	7
3	6000436	BEZEL, parking brake lever . . . . .	1
4	6000441	FASTENER, parking brake bezel . . . . .	7
5	6000440	BOOT, parking brake lever bezel . . . . .	1
6	N/S	LOCKNUT, 1/4 - 20, parking brake lever. . . . .	5
7	N/S	BOLT, 1/4 - 20 x 1, parking brake . . . . .	6
8	138084	PIN, parking brake lever, clevis. . . . .	1
9	N/S	LOCKNUT, 1/4 - 20, dust boot . . . . .	2
10	12338295	BOOT, dust, upper parking brake. . . . .	1
11	5939484	BOOT, dust, lower parking brake . . . . .	1
12	12338285	CLEVIS, rod end, front parking brake . . . . .	1
13	N/S	NUT, 5/16 - 24, clevis rod . . . . .	1
14	12341895	CLEVIS ROD, parking brake . . . . .	1
15	6001224	SLEEVE, parking brake rod . . . . .	1
16	12341902	BAR, brake cable equalizer . . . . .	1
17	12341897	WASHER, parking brake clevis rod, conical . . . . .	1
18	N/S	LOCKNUT, 5/16 - 24, parking brake clevis rod. . . . .	1
19	6002426B2	BRACKET, spring, retaining . . . . .	1
20	12338866	SPRING, extension . . . . .	1
21	5939457	CLIP, parking brake lower dust boot . . . . .	6
22	N/S	WASHER, flat, 3/8, clevis pin . . . . .	1
23	N/S	COTTER PIN, clevis pin . . . . .	1

# 2001 HUMMER PARTS CATALOG

## 7-4 BRAKES

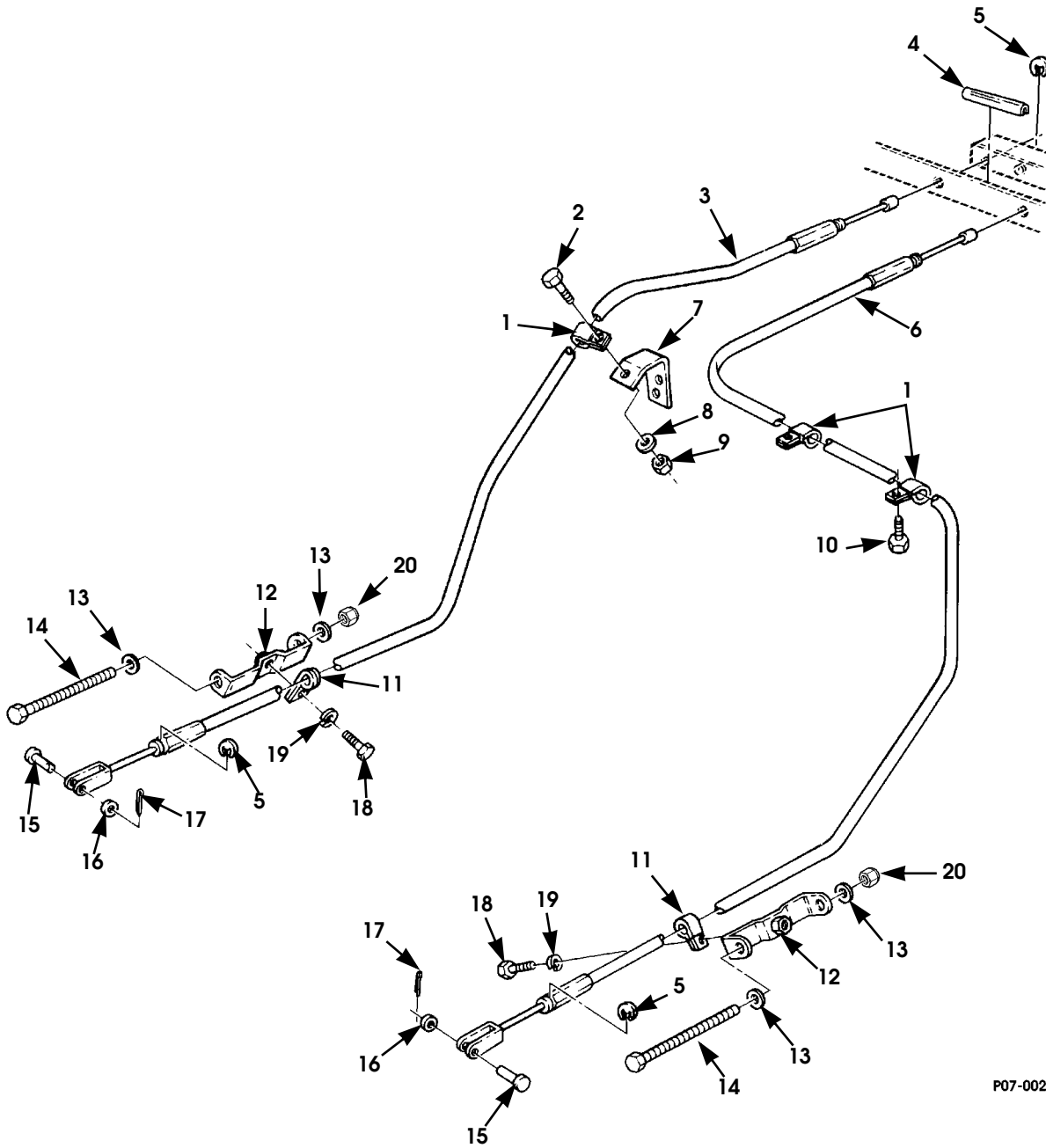

P07-002.1

Figure 7-2. Parking Brake Cables and Mounting Hardware

# 2001 HUMMER PARTS CATALOG

## BRAKES 7-5

ITEM	PART NUMBER	DESCRIPTION	QTY
		<b>Figure 7-2. Parking Brake Cables and Mounting Hardware</b>	
1	N/S	CLAMP,parking brake cable,harness, rear . . . . .	3
2	N/S	BOLT, 1/4 - 20 x 3/4,parking brake cable clamp . . . . .	1
3	12341898-1	CABLE,parking brake,L.H. . . . .	1
4	12339902-11	PROTECTOR,edge,2-inch . . . . .	1
5	MS16633-1050	RETAINING RING,parking brake cable, clip extension. . . . .	4
6	12341898-3	CABLE,parking brake,R.H. . . . .	1
7	12341906	BRACKET,parking brake cable . . . . .	1
8	N/S	WASHER,flat,1/4",parking brake cable bracket. . . . .	1
9	N/S	NUT,1/4 - 20,parking brake cable bracket . . . . .	1
10	N/S	SCREW,tapping,#10 - 32 x 3/8. . . . .	2
11	N/S	CLAMP,parking brake cables,harness . . . . .	2
12	12342965	BRACKET,parking brake cable,R.H. . . . .	1
12	12342966	BRACKET,parking brake cable,L.H. . . . .	1
13	N/S	WASHER,flat,1/4,parking brake cable brackets. . . . .	4
14	N/S	SCREW,1/4-20 x 4 1/2,parking brake cable brackets.	2
15	138084	PIN,clevis,parking brake cables. . . . .	2
16	N/S	WASHER,flat,3/8,parking brake cables . . . . .	2
17	N/S	COTTER PIN,parking brake cables . . . . .	2
18	N/S	BOLT,1/4 - 20 x 0.625,parking brake cable clamps . .	2
19	N/S	LOCKWASHER,1/4,parking brake cable clamps . . . .	2
20	N/S	LOCKNUT,1/4-20,parking brake cable brackets. . . . .	2

# 2001 HUMMER PARTS CATALOG

## 7-6 BRAKES

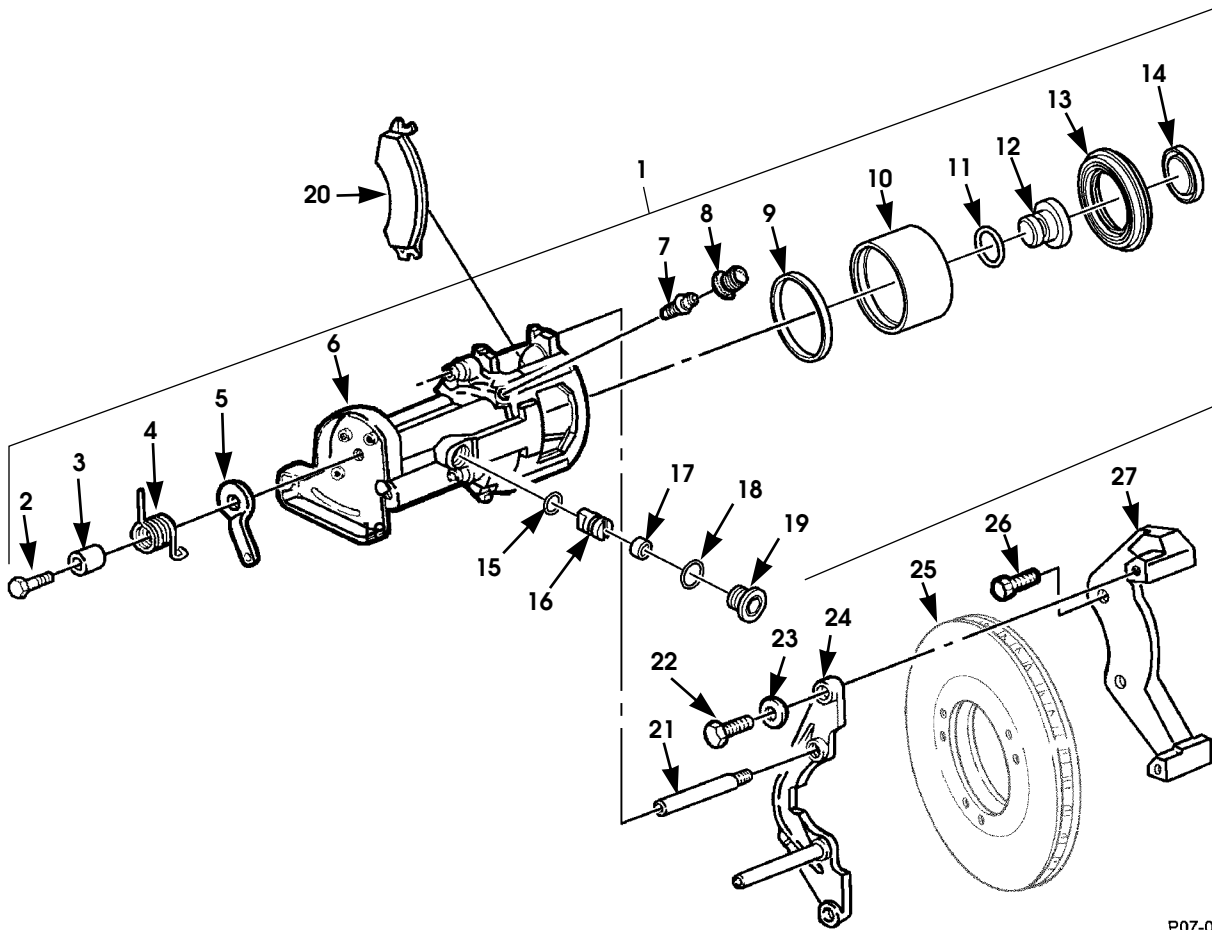

P07-003

Figure 7-3. Rear Service and Parking Brake Caliper Assembly and Rotor.

# 2001 HUMMER PARTS CATALOG

## BRAKES 7-7

ITEM	PART NUMBER	DESCRIPTION	QTY
		<b>Figure 7-3. Rear Service and Parking Brake Caliper Assembly and Rotor.</b>	
1	12342342	BRAKE CALIPER, R.H., rear . . . . .	1
1	12342341	BRAKE CALIPER, L.H., rear . . . . .	1
1	5745290	BRAKE CALIPER, L.H., rear, reman . . . . .	1
1	5745291	BRAKE CALIPER, R.H., rear, reman . . . . .	1
2	5741889	•CAPSCREW . . . . .	1
3	5741890	•CUP, spring . . . . .	1
4	5741995	•SPRING, parking brake, L.H. . . . .	1
4	5741994	•SPRING, parking brake, R.H. . . . .	1
5	5741750	•ARM, lever, L.H. . . . .	1
5	5741748	•ARM, lever, R.H. . . . .	1
6	S.I.A.	•HOUSING, rear brake caliper . . . . .	1
7	5578802	•BLEEDER VALVE . . . . .	1
8	5597172	•CAP, bleeder valve . . . . .	1
9	5578797	•SEAL, piston, SEE NOTE 1 . . . . .	1
10	5744404	•PISTON . . . . .	1
11	S.I.K.	•O-RING, thrust screw, SEE NOTE 2 . . . . .	1
12	S.I.A.	•CONICAL CLUTCH. . . . .	1
13	5578800	•DUST BOOT, piston, SEE NOTE 1 . . . . .	1
14	S.I.K.	•DUST CAP, piston, SEE NOTE 2 . . . . .	1
15	S.I.K.	•O-RING, anti-rotation pin, SEE NOTE 2 . . . . .	1
16	S.I.A.	•GUIDE PIN. . . . .	1
17	S.I.A.	•SPACER . . . . .	1
18	S.I.K.	•O-RING, pin retaining plug, SEE NOTE 2. . . . .	1
19	S.I.A.	•PLUG, allen head . . . . .	1
20	S.I.K.	PAD, disc brake, SEE NOTE 3 . . . . .	2
21	12342339	PIN, caliper . . . . .	2
22	5584071	SCREW, hex head, Gr8 . . . . .	2
23	5584072	WASHER, flat . . . . .	2
24	5573090	YOKE, disc brake . . . . .	1
25	12338387	ROTOR, disc brake . . . . .	2
26	N/S	BOLT, 5/8 - 11 x 1 1/2, Gr8, adapter. . . . .	4
27	5742123	ADAPTER. . . . .	1
		NOTE 1: PART OF SERVICE BRAKE CALIPER BOOT AND SEAL KIT P/N 5579865. ONE (1) KIT HAS ENOUGH COMPONENTS FOR TWO (2) BRAKE CALIPERS.	
		NOTE 2: PART OF REAR CALIPER RESEAL KIT P/N 5744405. RESEAL KIT INCLUDES ACTUATOR SHAFT O-RING (NOT ILLUSTRATED).	
		NOTE 3: PART OF SERVICE BRAKE PAD KITS P/N 5745162 (FOR 10,300 LB. GVW, 10,800 LB. GVW VEHICLES) AND 57K0264 (FOR 12,100 LB. GVW VEHICLES). KIT CONTAINS FOUR PADS TO SERVICE ONE AXLE.	



# 2001 HUMMER PARTS CATALOG

## 7-8 BRAKES

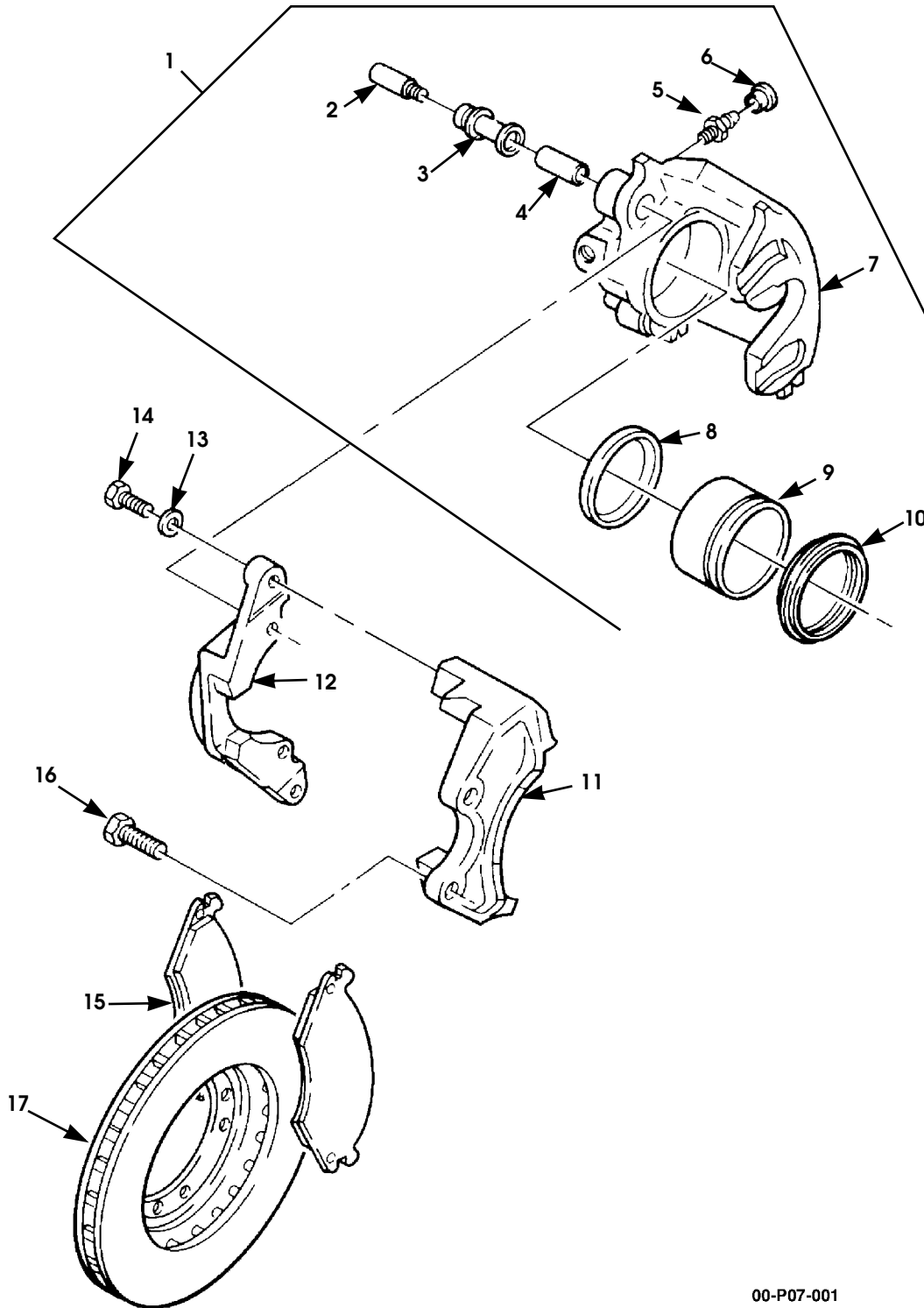

00-P07-001

Figure 7-4. Front Service Brake Caliper Assembly and Rotor

# 2001 HUMMER PARTS CATALOG

## BRAKES 7-9

ITEM	PART NUMBER	DESCRIPTION	QTY
		<b>Figure 7-4. Front Service Brake Caliper Assembly and Rotor</b>	
1	5572426	BRAKE CALIPER, L.H. front . . . . .	1
1	5572430	BRAKE CALIPER, R.H. front . . . . .	1
1	5745288	BRAKE CALIPER, L.H. front, reman . . . . .	1
1	5745289	BRAKE CALIPER, R.H. front, reman . . . . .	1
2	12342339	•PIN, caliper, locating . . . . .	2
3	5578806	•BUSHING, caliper . . . . .	2
4	5578794	•SLEEVE, caliper . . . . .	2
5	5578802	•BLEEDER VALVE, caliper . . . . .	1
6	5597172	•CAP, bleeder valve . . . . .	1
7	S.I.K.	•HOUSING, front brake caliper . . . . .	1
8	5578797	•SEAL, piston, SEE NOTE 1 . . . . .	1
9	5578803	•PISTON, caliper . . . . .	1
10	5578800	•BOOT, caliper, piston, SEE NOTE 1 . . . . .	1
11	5578809	ADAPTER, L.H. front . . . . .	1
11	5742123	ADAPTER, R.H. front . . . . .	1
12	5573090	YOKE, disc brake . . . . .	1
13	5584072	WASHER, flat, yoke to adapter . . . . .	2
14	5584071	BOLT, yoke to adapter, hex head . . . . .	2
15	S.I.K.	PAD, disc brake, SEE NOTE 2 . . . . .	2
16	N/S	BOLT, 5/8 - 11 x 1 1/2, Gr8 . . . . .	4
17	12338387	ROTOR, disc brake . . . . .	2
		NOTE 1: PART OF SERVICE BRAKE CALIPER BOOT AND SEAL KIT P/N 5579865. ONE (1) KIT HAS ENOUGH COMPONENTS FOR TWO (2) BRAKE CALIPERS.	
		NOTE 2: PART OF SERVICE BRAKE PAD KITS P/N 5745162 (FOR 10,300 LB. GVW, 10,800 LB. GVW VEHICLES) AND 57K0264 (FOR 12,100 LB. GVW VEHICLES). KIT CONTAINS FOUR PADS TO SERVICE ONE AXLE.	

# 2001 HUMMER PARTS CATALOG

## 7-10 BRAKES

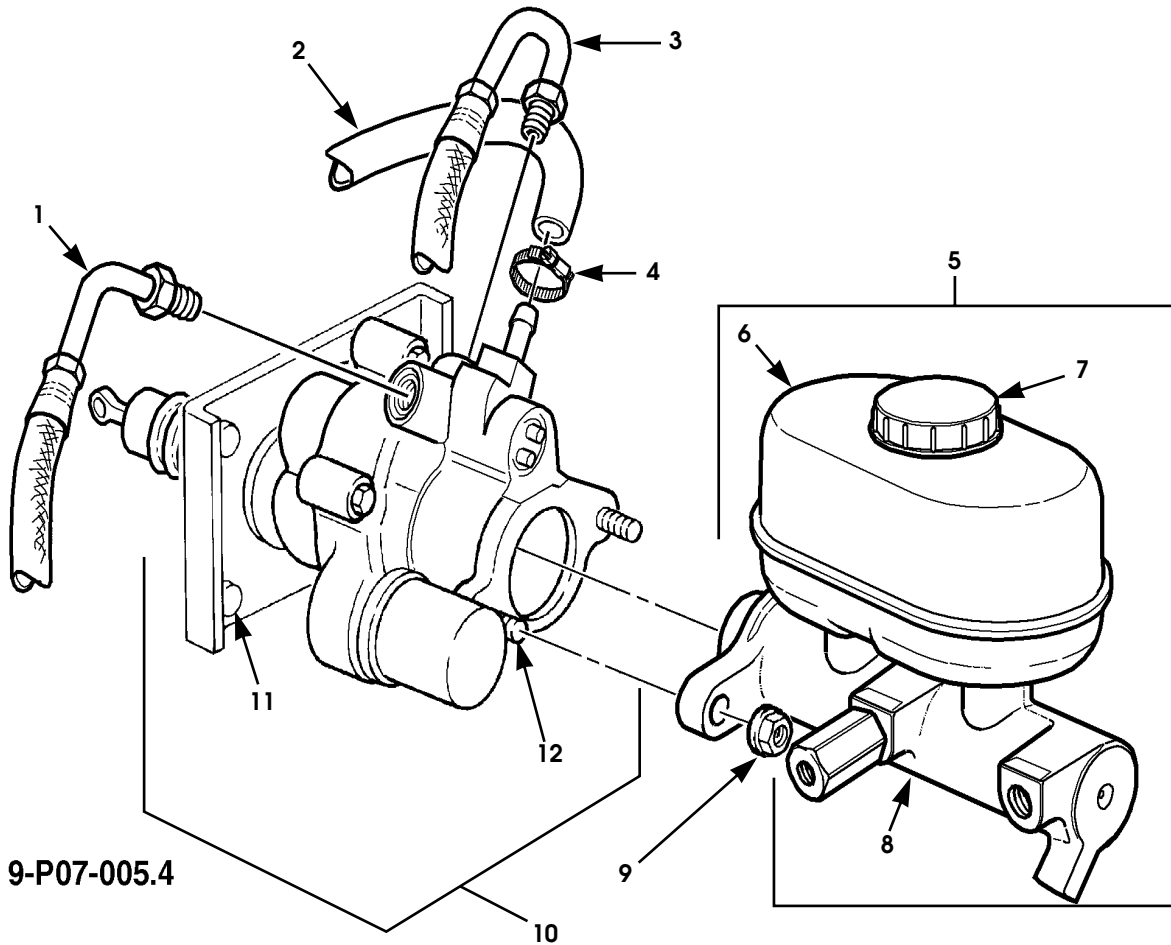

Figure 7-5. Master Cylinder Assembly and Hydro-Boost Assembly

# 2001 HUMMER PARTS CATALOG

## BRAKES 7-11

ITEM	PART NUMBER	DESCRIPTION	QTY
		<b>Figure 7-5. Master Cylinder Assembly and Hydro-Boost Assembly</b>	
1	6009990	HOSE ASSEMBLY, p/s pump-to-Hydro-Boost . . . . .	1
2	N/S	HOSE, Hydro-Boost-to-p/s pump, SEE NOTE 1 . . . . .	1
3	6009989	HOSE ASSEMBLY, Hydro-Boost-to-steering gear . . . . .	1
4	N/S	HOSE CLAMP, 5/8 . . . . .	1
5	6009992	MASTER CYLINDER ASSEMBLY . . . . .	1
6	S.I.A.	• RESERVOIR, master cylinder . . . . .	1
7	S.I.A.	• COVER, master cylinder . . . . .	1
8	S.I.A.	• MASTER CYLINDER . . . . .	1
9	N/S	LOCKNUT, flanged, pt, 3/8 - 16 . . . . .	2
10	6010096	HYDRO-BOOST ASSEMBLY . . . . .	1
11	S.I.A.	• STUD, 3/8 - 16 x 1 1/2, Hydro-Boost-to-cowl . . . . .	4
12	5745116	• STUD, 3/8 - 16 x 1 9/16, Hydro-Boost-to-m/c. . . . .	2
	6010409	DECAL, master cylinder, GCC (not illustrated) . . . . .	1
		NOTE 1: MAKE FROM BULK HOSE, P/N 5741209, 5/8" O.D. X 3/8" I.D. X 25 FEET LONG	

# 2001 HUMMER PARTS CATALOG

## 7-12 BRAKES

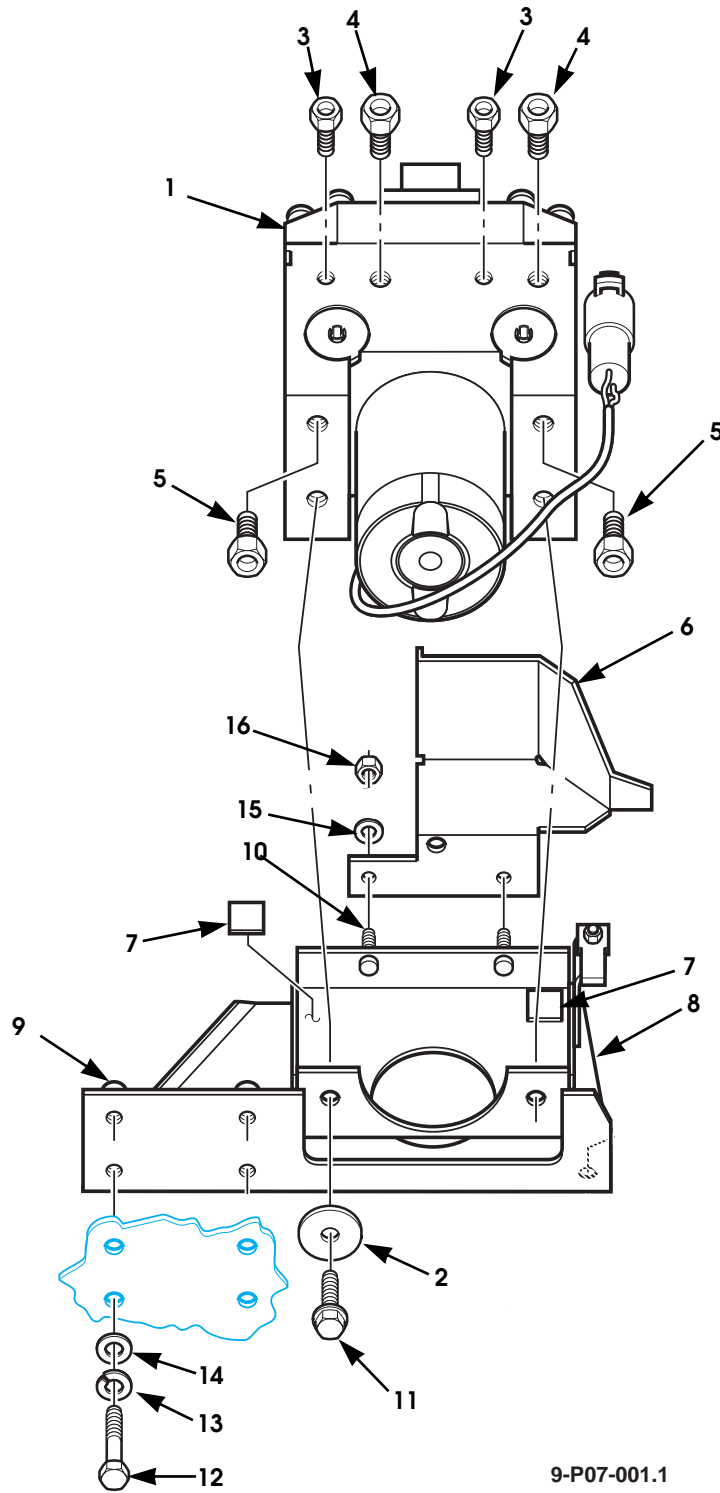

Figure 7-6. ABS Modulator.

# 2001 HUMMER PARTS CATALOG

## BRAKES 7-13

ITEM	PART NUMBER	DESCRIPTION	QTY
		<b>Figure 7-6. ABS Modulator.</b>	
1	6010138	ABS MODULATOR ASSEMBLY, wet. . . . .	1
2	S.I.A.	•WASHER, flat, 25mm O.D. x 6mm I.D. . . . .	2
3	6010824	ADAPTER, modulator to R.H. side . . . . .	2
4	6010825	ADAPTER, modulator to L.H. side . . . . .	2
5	6010823	ADAPTER, master cylinder to modulator. . . . .	2
6	6008984	SHIELD, ABS modulator . . . . .	1
7	6011036	SPACER, modulator mounting . . . . .	2
8	6008985B9	BRACKET ASSEMBLY, ABS modulator . . . . .	1
9	S.I.A.	•NUT INSERT, 3/8 - 16 . . . . .	4
10	S.I.A.	•STUD, 1/4 - 20 x 1 . . . . .	4
11	N/S	BOLT, M5 - 0.8 x 13 . . . . .	2
12	N/S	BOLT, 3/8 - 16 x 1 1/4. . . . .	4
13	N/S	LOCKWASHER, 3/8. . . . .	4
14	N/S	WASHER, flat, 3/8 . . . . .	4
15	N/S	WASHER, flat, 1/4 . . . . .	2
16	N/S	LOCKNUT, pt, 1/4 - 20. . . . .	2

# 2001 HUMMER PARTS CATALOG

## 7-14 BRAKES

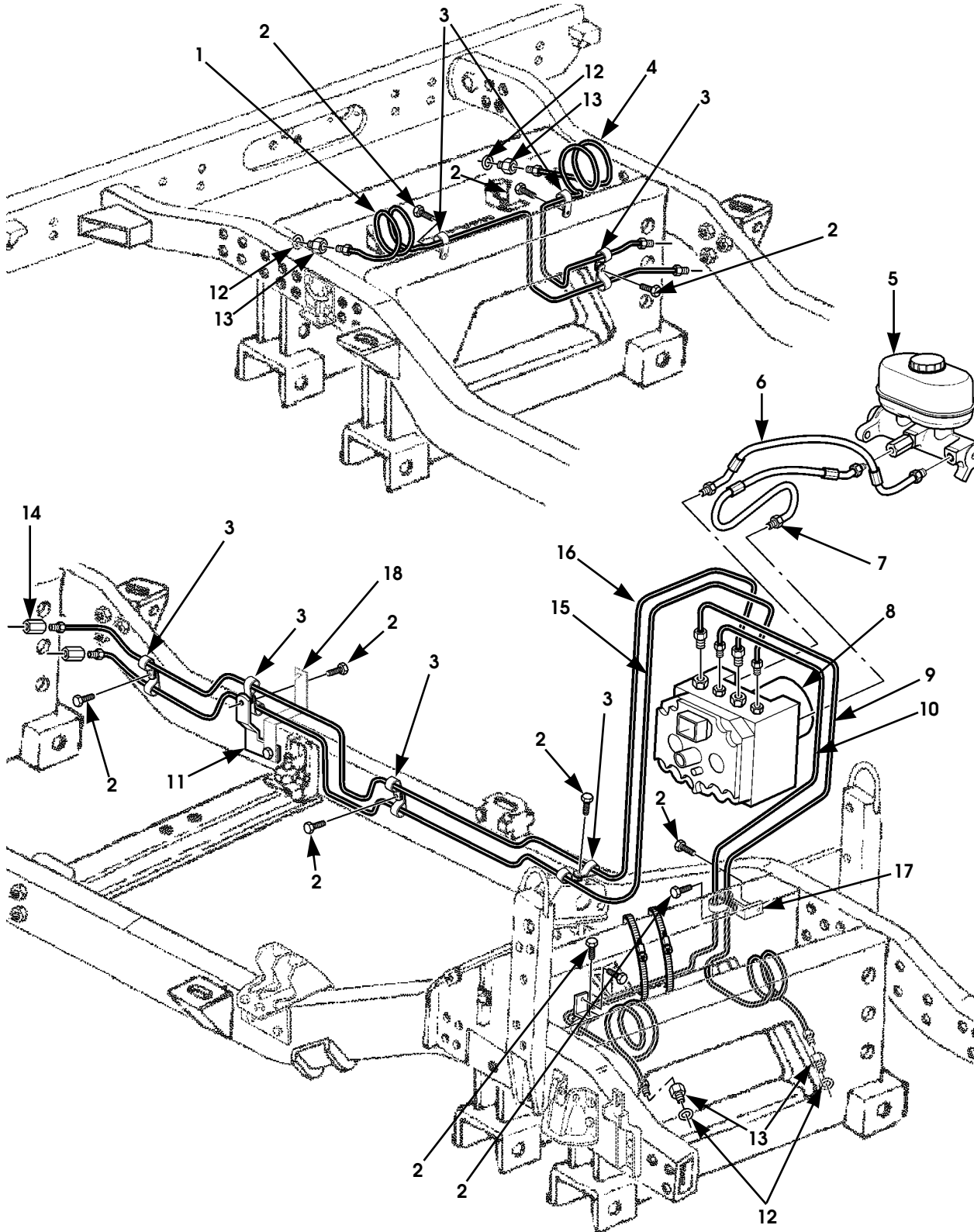

9-P07-002.2

Figure 7-7. Brake Lines.

# 2001 HUMMER PARTS CATALOG

## BRAKES 7-15

ITEM	PART NUMBER	DESCRIPTION	QTY
		<b>Figure 7-7. Brake Lines.</b>	
1	6008928	BRAKE LINE, R.H. union-to-R.H. rear caliper, red . . . . .	1
2	N/S	SCREW, tapping, 3/8 - 16 x 5/8 . . . . .	11
3	N/S	P-CLAMP, 5/16" I.D. . . . .	15
4	6008926	BRAKE LINE, L.H. union-to-L.H. rear caliper, orange . . .	1
5	6009992	MASTER CYLINDER . . . . .	1
6	6011258	TUBE AND HOSE ASSEMBLY, primary, m/c-to-modulator	1
7	6011257	TUBE AND HOSE ASSEMBLY, secondary, m/c-to-modulator	1
8	6010138	MODULATOR, ABS . . . . .	1
9	6008918	BRAKE LINE, modulator-to-L.H. front caliper, yellow . . .	1
10	6008920	BRAKE LINE, modulator-to-R.H. front caliper, green . . .	1
11	12447165	BRACKET, brake line mounting . . . . .	1
12	12339204	WASHER, brake caliper . . . . .	4
13	12339235	COUPLING, brake caliper . . . . .	4
14	442393	UNION, brake line . . . . .	2
15	6008924	BRAKE LINE, intermediate, modulator-to-R.H. union, red.	1
16	6008922	BRAKE LINE, intermediate, modulator-to-L.H. union, orange . . . . .	1
17	12338301	BRACKET, brakeline . . . . .	2
18	6002426B2	BRACKET, spring retaining . . . . .	1



# 2001 HUMMER PARTS CATALOG

## 7-16 BRAKES

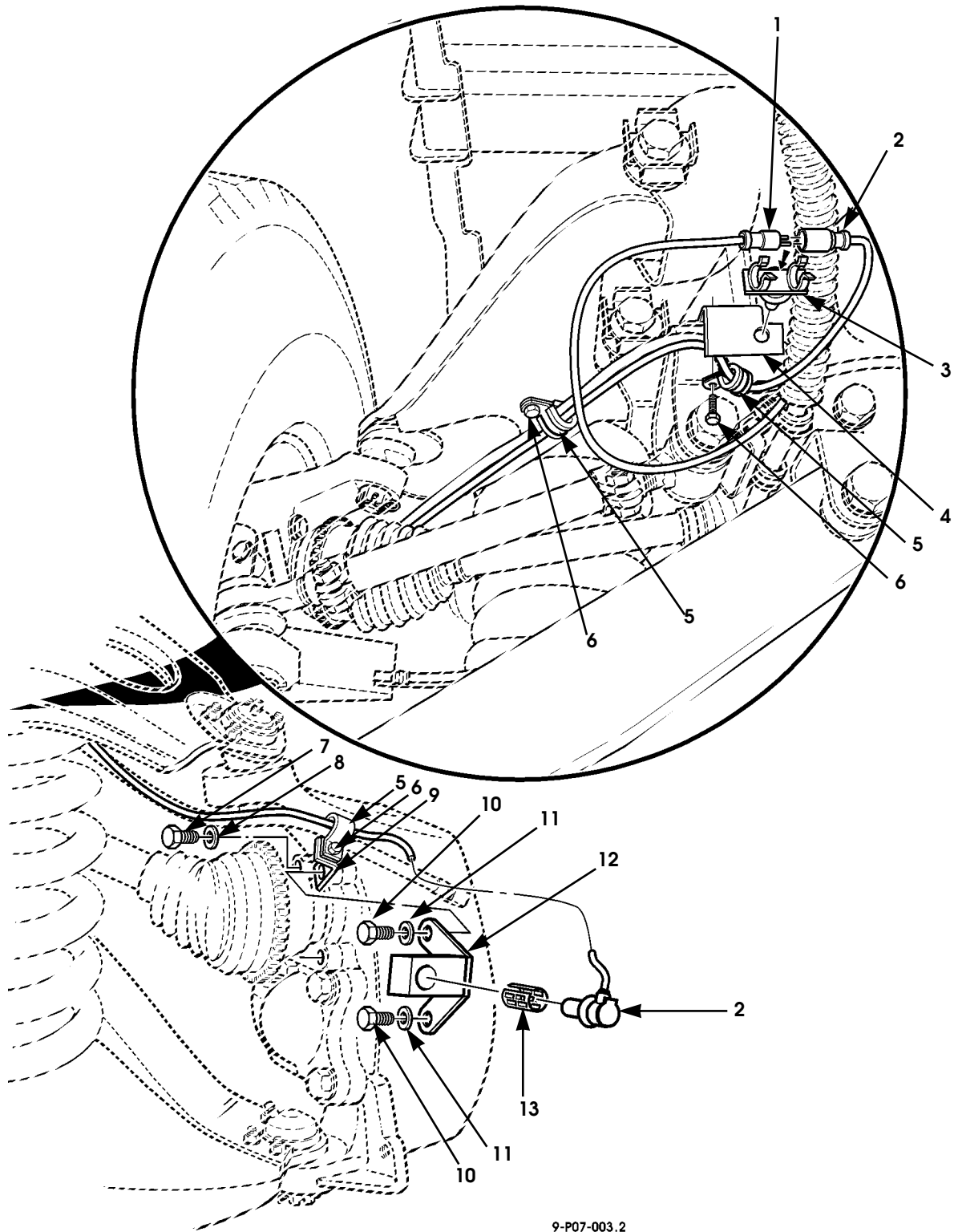

9-P07-003.2

Figure 7-8. ABS Wheel Speed Sensor.

# 2001 HUMMER PARTS CATALOG

## BRAKES 7-17

ITEM	PART NUMBER	DESCRIPTION	QTY
		<b>Figure 7-8.</b> <b>ABS Wheel Speed Sensor.</b>	
1	6010137	JUMPER, ASSEMBLY, wheel speed sensor, SEE NOTE 1 .	1
2	6008841	ABS WHEEL SPEED SENSOR . . . . .	4
3	6010259	CLIP, speed sensor connection mount . . . . .	4
4	6010677B9	BRACKET, speed sensor connection clip, rear only SEE NOTE 2. . . . .	2
5	MS21333-67	P-CLAMP, cushioned, 1/4", SEE NOTE 3 . . . . .	2
5	N/S	P-CLAMP, cushioned, 1/2", SEE NOTE 2 . . . . .	6
5	MS21333-125	P-CLAMP, Cushioned, 5/8", SEE NOTE 4 . . . . .	3
5	MS21333-125	P-CLAMP, Cushioned, 5/8", SEE NOTE 1 . . . . .	2
6	N/S	SCREW, tapping, #10 - 24 x 1/2, SEE NOTE 3 . . . . .	2
6	N/S	SCREW, tapping, 3/8 - 16 x 5/8, SEE NOTE 2. . . . .	4
6	N/S	SCREW, tapping, 3/8 - 16 x 5/8, SEE NOTE 5. . . . .	9
7	N/S	SCREW, 3/8 - 16 x 1, on hub, SEE NOTE 3 . . . . .	2
8	N/S	WASHER, flat, 3/8, on hub, upper front, SEE NOTE 3 . . .	2
9	5598208	BRACKET, 90-degree, on hub . . . . .	4
10	N/S	SCREW, 3/8 - 16 x 1, on hub rear. . . . .	8
10	N/S	SCREW, 3/8 - 16 x 1, on hub, upper rear, SEE NOTE 6 . .	2
11	N/S	WASHER, flat, 3/8, on hub, upper rear, SEE NOTE 6 . . . .	2
11	N/S	WASHER, flat, 3/8, on hub, rear . . . . .	8
12	6009899B9	HOUSING ASSEMBLY, ABS wheel speed sensor mounting	4
13	6008840	BUSHING, ABS wheel speed sensor mounting . . . . .	4
	12340571-2	P-CLAMP, coated, 1", (not illustrated), SEE NOTE 7 . . . .	2
	EC12338170	BRACKET, 90-degree, (not illustrated), SEE NOTE 1 . . . .	1
	6010767	BRACKET, 90-degree, (not illustrated), SEE NOTE 7 . . . .	2
		NOTE 1: FOR R.H. FRONT ONLY	
		NOTE 2: FOR REAR ONLY	
		NOTE 3: FOR L.H. SIDE ONLY	
		NOTE 4: FOR L.H. FRONT ONLY	
		NOTE 5: FOR L.H. FRONT, L.H. REAR, AND R.H. FRONT ONLY	
		NOTE 6: FOR R.H. SIDE ONLY	
		NOTE 7: FOR FRONT ONLY	

# 2001 HUMMER PARTS CATALOG

## 7-18 BRAKES

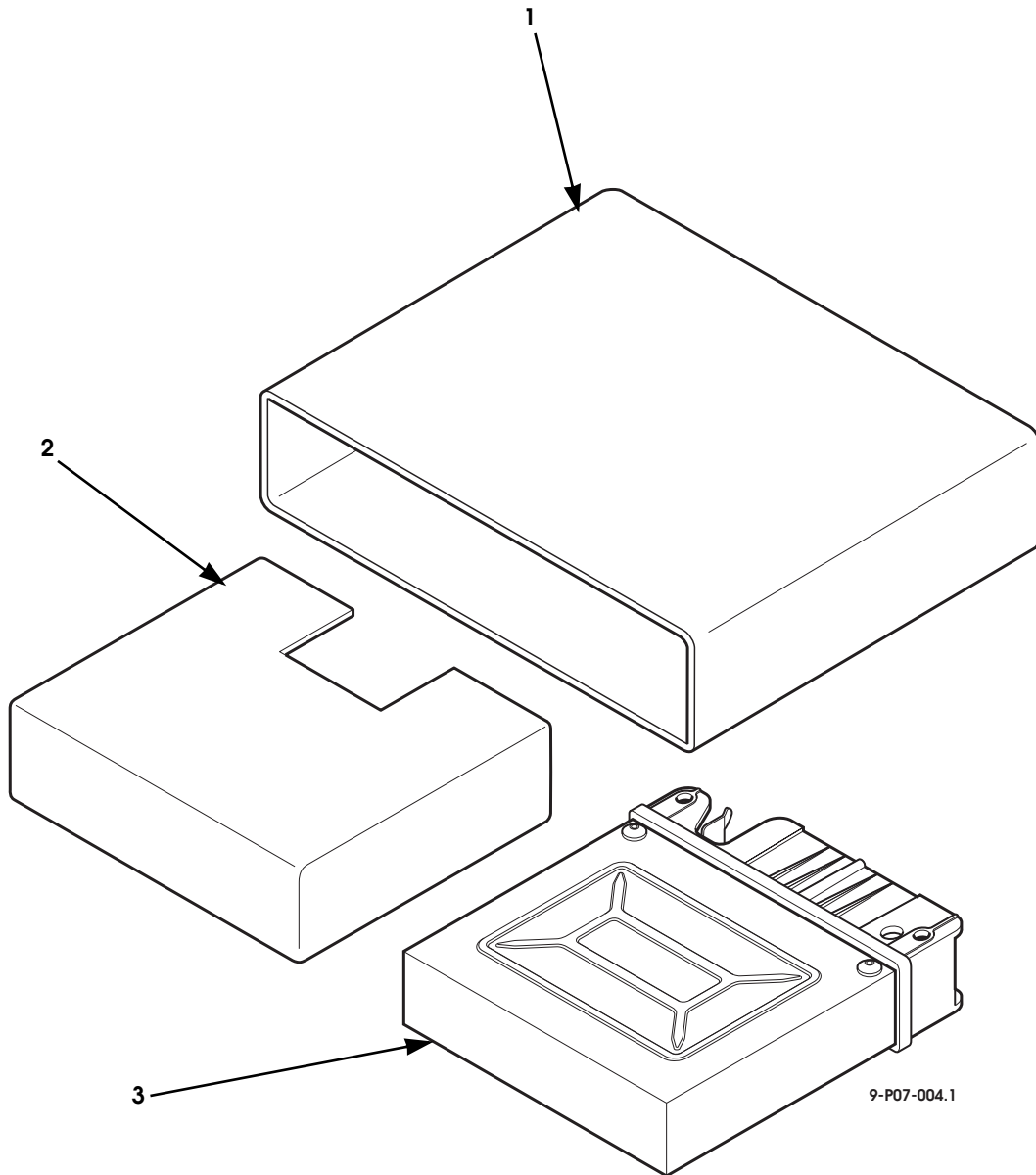

Figure 7-9. ABS Electronic Control Unit (ECU).

# 2001 HUMMER PARTS CATALOG

## BRAKES 7-19

ITEM	PART NUMBER	DESCRIPTION	QTY
		<b>Figure 7-9.</b> <b>ABS Electronic Control Unit (ECU).</b>	
1	6010398	HOUSING, ECU, upper . . . . .	1
2	6010399	HOUSING, ECU, lower . . . . .	1
3	6008899	ELECTRONIC CONTROL UNIT (ECU), ABS . . . . .	1

# 2001 HUMMER PARTS CATALOG

## 7-20 BRAKES

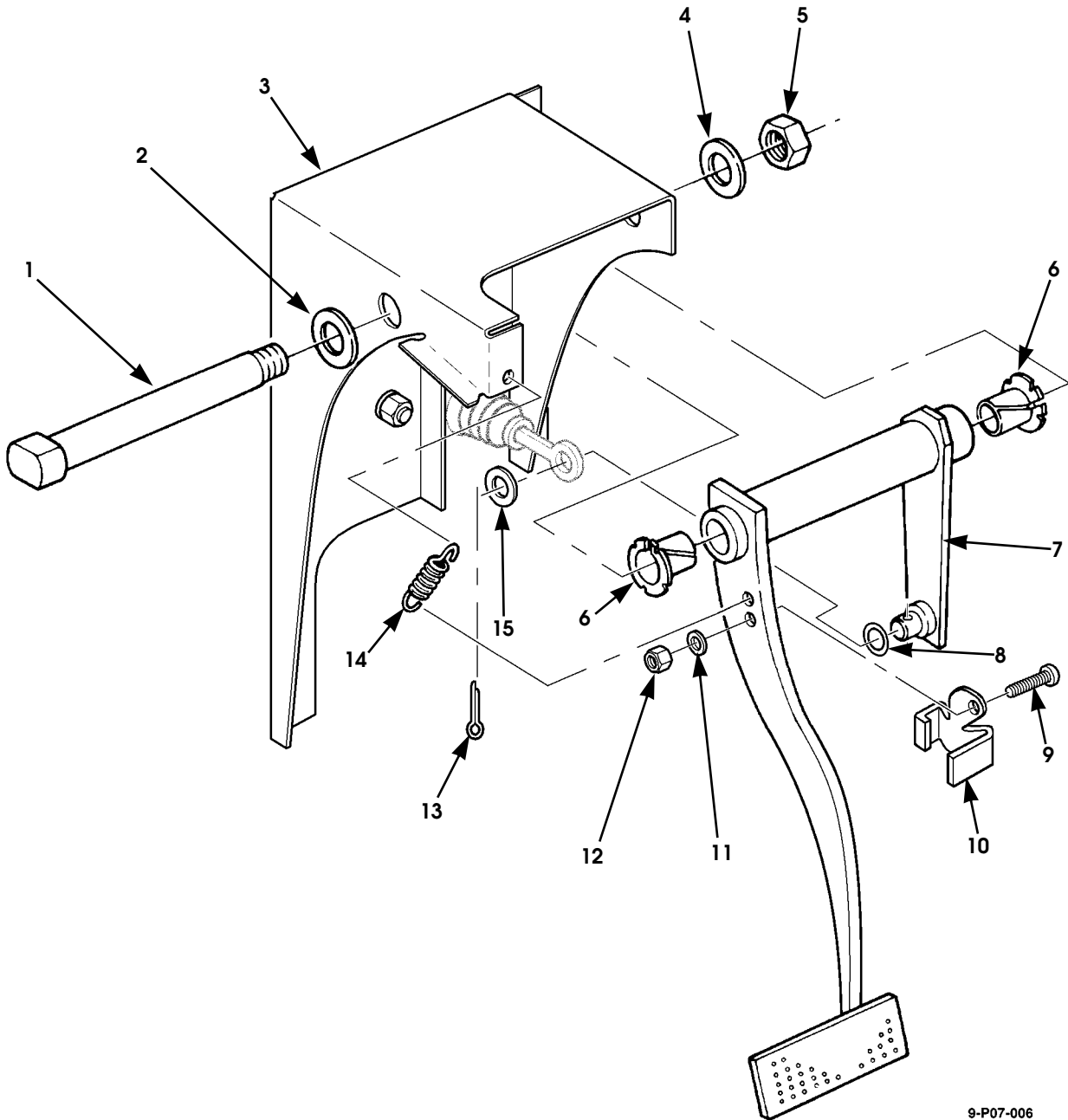

9-P07-006

Figure 7-10. Service Brake Pedal Assembly.

# 2001 HUMMER PARTS CATALOG

## BRAKES 7-21

ITEM	PART NUMBER	DESCRIPTION	QTY
		<b>Figure 7-10. Service Brake Pedal Assembly.</b>	
1	12339114	PIN, brake pedal . . . . .	1
2	N/S	WASHER, flat, hardened, 3/4, type B, pin . . . . .	1
3	12338732P	BRACKET, brake pedal mounting. . . . .	1
4	N/S	WASHER, flat, hardened, 9/16, type B, pin . . . . .	1
5	N/S	LOCKNUT, 9/16 - 12, Gr8, CAD, pin . . . . .	1
6	12339112-2	BEARING, pin . . . . .	2
7	WA12338394B1	BRAKE PEDAL . . . . .	1
8	12338124	WASHER, wave, 1/2, brake pedal to Hydro-Boost . . . . .	1
9	N/S	SCREW, #10 - 24 x 1, brake pedal striker . . . . .	1
10	6003075	STRIKER, brake light switch . . . . .	1
11	N/S	WASHER, flat, #10 . . . . .	1
12	N/S	LOCKNUT, #10 - 24 . . . . .	1
13	N/S	COTTER PIN, 3/32" x 1". Phos, brake pedal to Hydro-Boost. . . . .	1
14	12339183	SPRING, brake pedal return . . . . .	1
15	N/S	WASHER, flat, 1/2, class 3, CAD, brake pedal to Hydro-Boost . . . . .	1

# 2001 HUMMER PARTS CATALOG

## 7-22 BRAKES

# 2001 HUMMER PARTS CATALOG

## STEERING SYSTEM 8-1

### Section 8

## STEERING SYSTEM

TITLE	PAGE NUMBER
Power Steering Gear and Mounting Hardware . . . . .	8-10
Power Steering Gear Assembly . . . . .	8-12
Power Steering Pump, Oil Cooler, and Hydro-Boost Lines and Fittings . . . . .	8-20
Power Steering Pump, Pulley, Reservoir, and Mounting Hardware. . . . .	8-18
Power Steering Pump . . . . .	8-16
Steering Column and Intermediate Shaft . . . . .	8-2
Steering Column Lock and Switch Housing Assembly . . . . .	8-6
Steering Column Trim and Turn Signal . . . . .	8-4
Steering Linkage . . . . .	8-8



# 2001 HUMMER PARTS CATALOG

## 8-2 STEERING SYSTEM

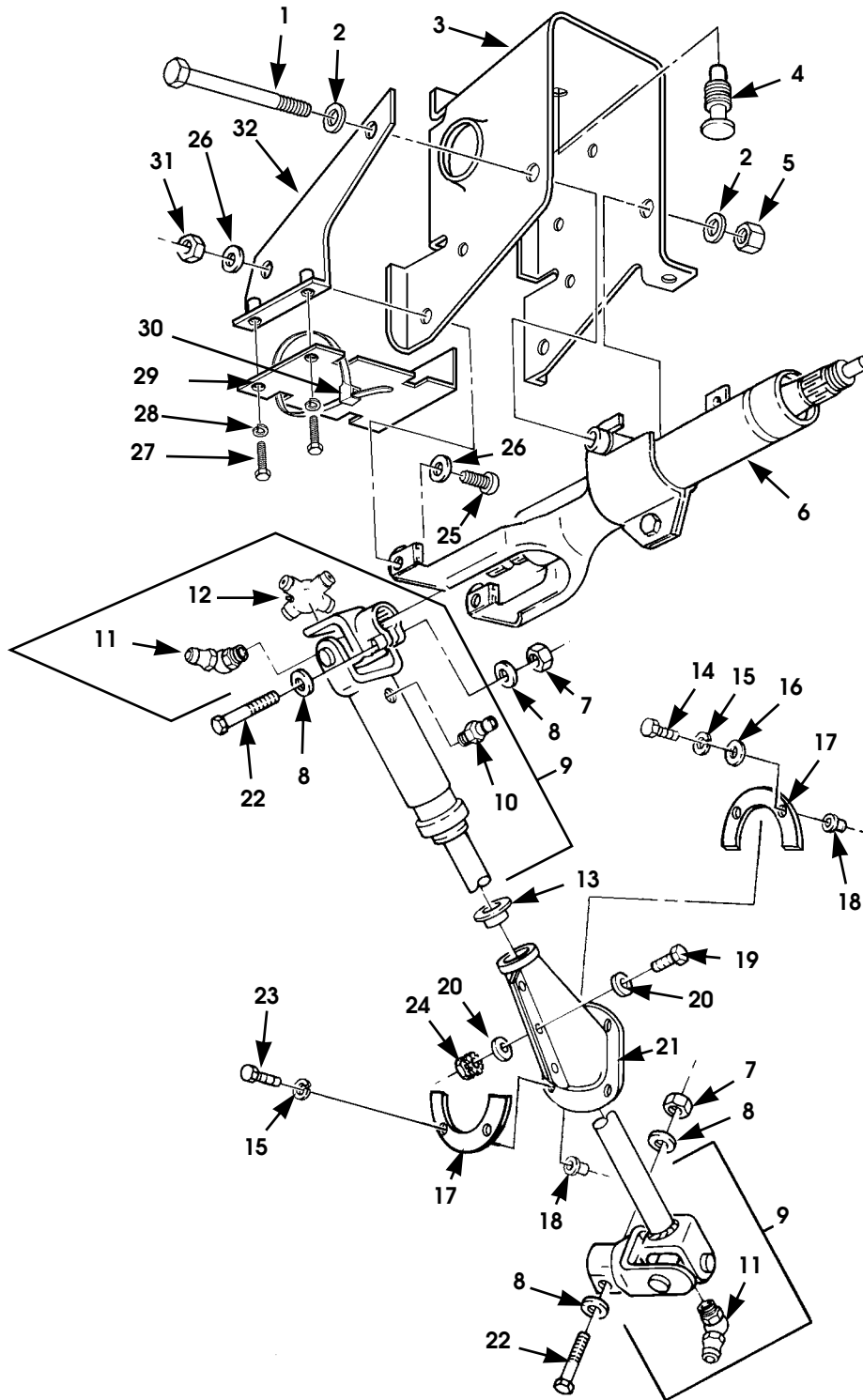

P08-001.5

Figure 8-1. Steering Column and Intermediate Shaft.

# 2001 HUMMER PARTS CATALOG

## STEERING SYSTEM 8-3

ITEM	PART NUMBER	DESCRIPTION	QTY
		<b>Figure 8-1. Steering Column and Intermediate Shaft.</b>	
1	N/S	BOLT, 3/8 - 16 x 5 1/2, Gr8, ZN, steering column . . . . .	1
2	N/S	LOCKWASHER, flat, 3/8" type b, hard, steering column.	2
3	5939226	BRACKET, steering column mounting . . . . .	1
4	12339402	DRIVE PIN, nylon. . . . .	1
5	N/S	LOCKNUT, 3/8 - 16, Gr8, steering column . . . . .	1
6	5939076	STEERING COLUMN, upper. . . . .	1
7	N/S	NUT, 7/16 - 20, Gr8, steering column . . . . .	2
8	N/S	WASHER, flat, 7/16, steering column . . . . .	4
9	12339210-2	SHAFT, intermediate steering . . . . .	1
10	MS15002-1	•LUBRICATION FITTING, intermediate shaft. . . . .	1
11	MS15003-4	•LUBRICATION FITTING, intermediate shaft. . . . .	2
12	5744602	•U-JOINT, intermediate shaft . . . . .	2
13	12341894	NYLINER, interior steering shaft boot . . . . .	1
14	N/S	BOLT, 1/4 - 20 x 1, Gr8, CAD, intermediate steering shaft	3
15	N/S	LOCKWASHER, 1/4, reinforcement. . . . .	4
16	N/S	WASHER, flat, 1/4, intermediate steering shaft . . . . .	3
17	5939997B1	REINFORCEMENT, steering column seal . . . . .	2
18	5937584	NUT INSERT . . . . .	4
19	N/S	SCREW, #10 - 24 x 3/4, steering shaft boot . . . . .	3
20	N/S	WASHER, flat, #10, steering shaft boot . . . . .	6
21	12341893	BOOT, dust and moist, steering shaft . . . . .	1
22	N/S	BOLT, 7/16 - 20 x 2, Gr8, CAD, steering column . . . . .	2
23	N/S	BOLT, 1/4 - 20 x 1 1/4, Gr8, CAD . . . . .	1
24	N/S	NUT, #10 - 24, steering shaft boot . . . . .	3
25	N/S	SCREW, 5/16 - 18 x 3/4, ZN, steering column assembly	2
26	N/S	WASHER, flat, hard, 5/16 . . . . .	4
27	N/S	BOLT, #10 - 24 x 1/2 . . . . .	2
28	N/S	LOCKWASHER, #10. . . . .	2
29	6011875	SUPPORT, cross body harness. . . . .	1
30	N/S	TIE WRAP, 10 1/4" . . . . .	2
31	N/S	LOCKNUT, 5/16 - 18, Gr8 . . . . .	2
32	6007699	BRACKET, cross body harness. . . . .	1

# 2001 HUMMER PARTS CATALOG

## 8-4 STEERING SYSTEM

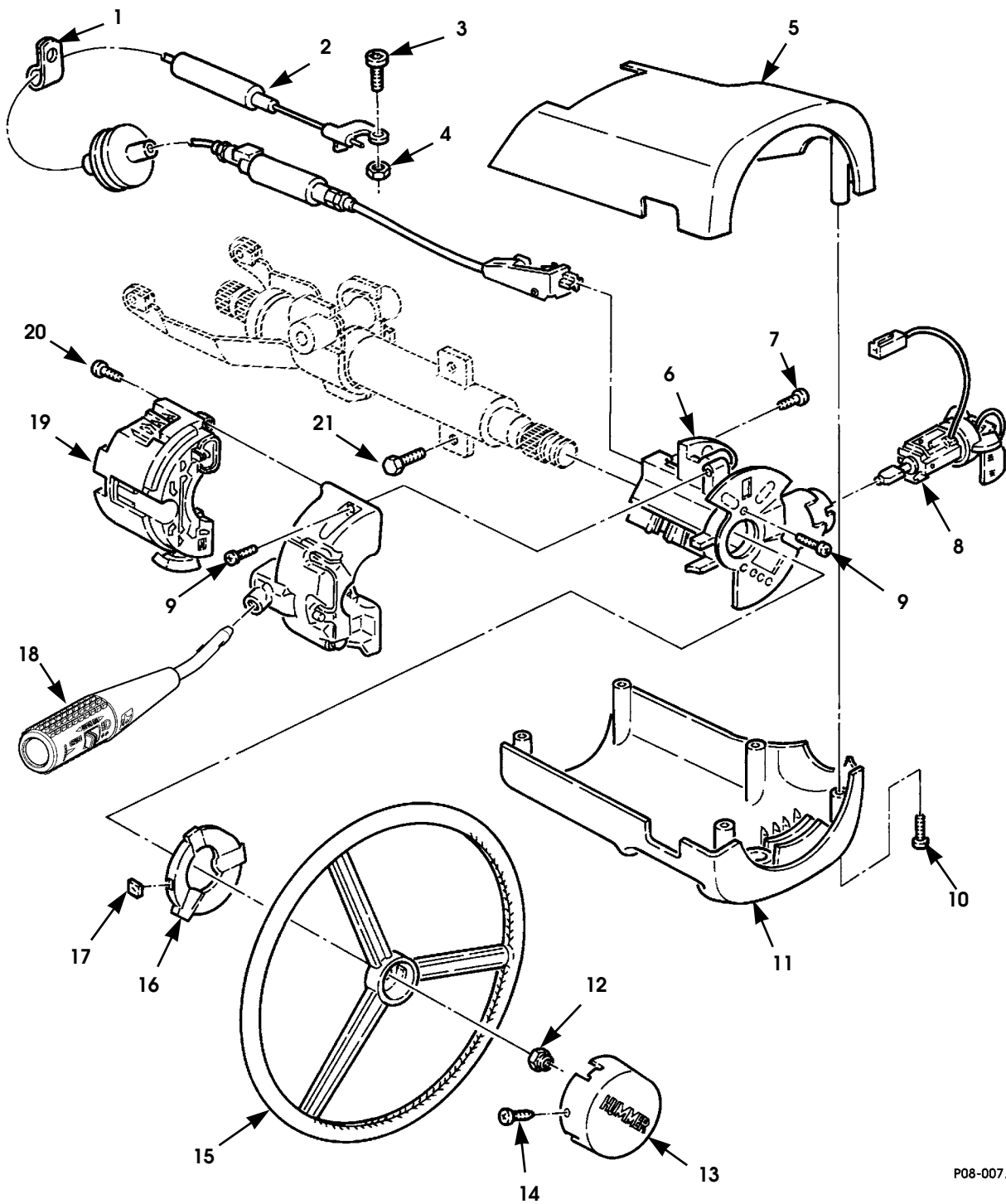

P08-007.1

Figure 8-2. Steering Column Trim and Turn Signal.

# 2001 HUMMER PARTS CATALOG

## STEERING SYSTEM 8-5

ITEM	PART NUMBER	DESCRIPTION	QTY
		<b>Figure 8-2. Steering Column Trim and Turn Signal.</b>	
1	N/S	CLAMP,cushioned,5/16" . . . . .	1
2	6007700	CABLE,ignition interlock . . . . .	1
3	N/S	SCREW,socket head cap,M6 - 1.0 x 16,class 10.9,ZN	1
4	N/S	LOCKNUT,M6 - 1.0,class 10.9 . . . . .	1
5	5939636	SHROUD,upper steering column. . . . .	1
6	5742768	HOUSING,lock and switch (See Figure 8-3) . . . . .	1
7	N/S	SCREW,#8 - 32 x 1/2 . . . . .	1
8	5939821	LOCK CYLINDER AND KEY ASSEMBLY, Ignition . . . . .	1
9	5742680	SCREW,steering column. . . . .	4
10	N/S	SCREW,tapping,phcr,#8 - 18 x 1 1/4, steering column shroud . . . . .	5
11	5939635	SHROUD,lower steering column . . . . .	1
12	7063812	NUT,steering wheel-to-column . . . . .	1
13	6000113	COVER,steering wheel hub. . . . .	1
14	N/S	SCREW,phcr,#8 - 18 x 1/2. . . . .	3
15	5939373	STEERING WHEEL ASSEMBLY,with cover and padding	1
16	6000112	ADAPTER,steering wheel hub cover. . . . .	1
17	5939659	GROMMET . . . . .	3
18	6009707	TURN SIGNAL LEVER,w/o cruise control . . . . .	1
18	6010416	TURN SIGNAL LEVER,cruise control . . . . .	1
19	5742688	SWITCH ASSEMBLY,turn,emergency,horn,and dimmer	1
20	N/S	SCREW,Torx head,#6-40 x 3/16 . . . . .	4
21	5742769	BOLT,steering column. . . . .	2

# 2001 HUMMER PARTS CATALOG

## 8-6 STEERING SYSTEM

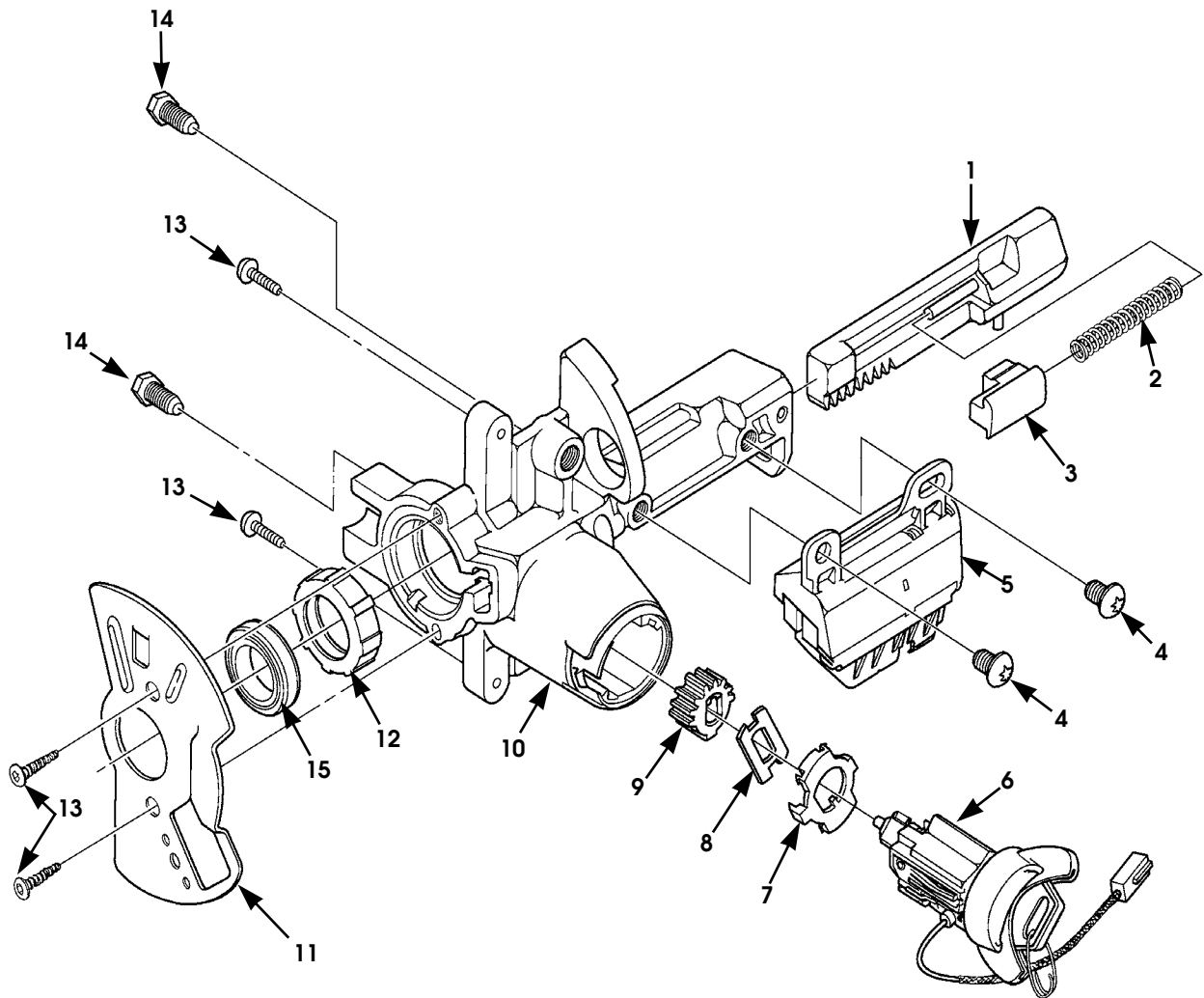

P08-008

Figure 8-3. Steering Column Lock and Switch Housing Assembly.

# 2001 HUMMER PARTS CATALOG

## STEERING SYSTEM 8-7

ITEM	PART NUMBER	DESCRIPTION	QTY
		<b>Figure 8-3. Steering Column Lock and Switch Housing Assembly.</b>	
1	5743340	ACTUATOR, column lock . . . . .	1
2	5743337	SPRING, steering column lock . . . . .	1
3	5743336	PAWL, steering column lock . . . . .	1
4	N/S	SCREW, M6-1.0 x 16 soc. hd cap 10 cl10 zn . . . . .	2
5	5743343	SWITCH ASSEMBLY, ignition . . . . .	1
6	5939821	CYLINDER AND KEY ASSEMBLY, ignition lock . . . . .	1
7	5743341	RETAINER, column lock gear . . . . .	1
8	5743338	FLAT BEARING, column lock . . . . .	1
9	5743339	GEAR, steering column lock. . . . .	1
10	5743342	HOUSING, lock cylinder. . . . .	1
11	N/S	•PLATE, bearing retainer. . . . .	1
12	5743344	SLEEVE, upper bearing . . . . .	1
13	5742680	SCREW, steering column . . . . .	4
14	N/S	BOLT, M8 - 1.25 x 24 . . . . .	2
15	5744891	BEARING ASSEMBLY, upper steering column . . . . .	1

# 2001 HUMMER PARTS CATALOG

## 8-8 STEERING SYSTEM

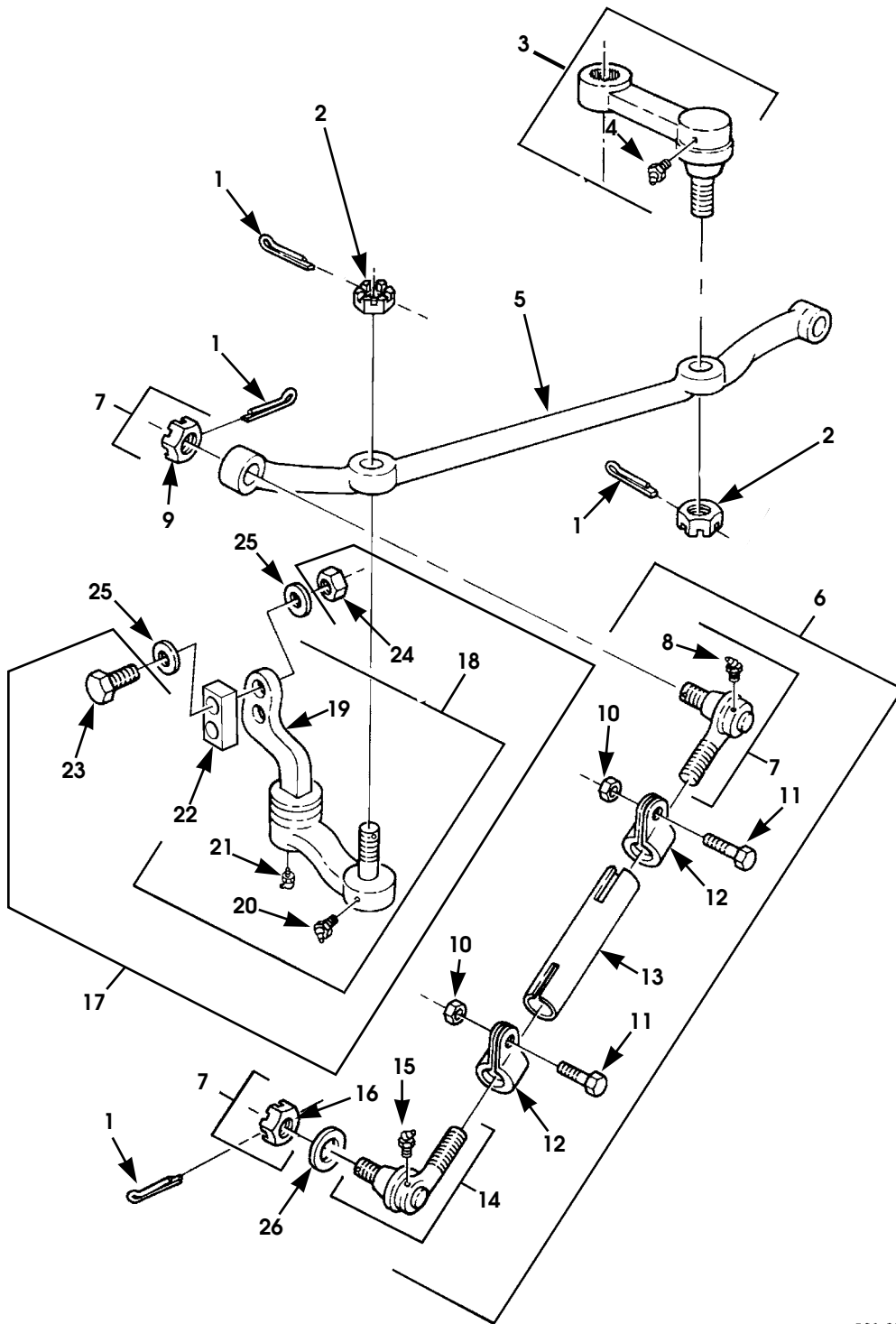

P08-002.1

Figure 8-4. Steering Linkage.

# 2001 HUMMER PARTS CATALOG

## STEERING SYSTEM 8-9

ITEM	PART NUMBER	DESCRIPTION	QTY
		<b>Figure 8-4. Steering Linkage.</b>	
1	N/S	COTTER PIN, 1/8" x 1 1/4", idler arm . . . . .	6
2	MS35692-54	NUT, slotted, . . . . .	2
3	6011300	ARM, steering. . . . .	1
4	MS15001-1	•FITTING, zerk, 1/4 - 28 x 3/16, steering arm . . . . .	1
5	6003868	CENTER LINK, steering . . . . .	1
6	6005119	TIE ROD ASSEMBLY, steering, left and right side . . . . .	2
7	12338311-2	•TIE ROD END, steering, R.H. thread. . . . .	1
8	MS15001-3	••FITTING, zerk, 45 degree, 1/4 - 28 x 3/16, tie rod end . . . . .	1
9	MS35692-54	••NUT, slotted, tie rod end . . . . .	1
10	N/S	•NUT, 7/16 - 14, Gr8, tie rod end clamp. . . . .	2
11	N/S	•BOLT, 7/16 - 14 x 1 3/4, Gr8, tie rod end clamp . . . . .	2
12	12339202	•CLAMP, tie rod end . . . . .	2
13	6005124	•ROD. . . . .	1
14	12338311-1	•TIE ROD END, steering L.H. thread . . . . .	1
15	MS15001-3	••FITTING, zerk, 45 degree, 1/4 - 28 x 3/16, tie rod end . . . . .	1
16	MS35692-54	••NUT, slotted, tie rod end . . . . .	1
17	5745340	KIT, idler arm . . . . .	1
18	S.I.K.	•IDLER ARM ASSEMBLY, steering. . . . .	1
19	S.I.A.	••IDLER ARM . . . . .	1
19	MS15001-1	••FITTING, zerk, 1/4 - 28 x 3/16, idler arm . . . . .	1
20	MS15001-3	••FITTING, zerk, 45 degrees, 1/4 - 28 x 3/16, idler arm . . . . .	1
21	S.I.A.	••SPACER . . . . .	1
22	EC9430230	•BOLT, hex . . . . .	2
23	9422299	•LOCKNUT . . . . .	2
24	N/S	WASHER, flat, type B, 7/16, idler arm . . . . .	4
25	N/S	WASHER, flat, hardened, 5/8. . . . .	1



# 2001 HUMMER PARTS CATALOG

## 8-10 STEERING SYSTEM

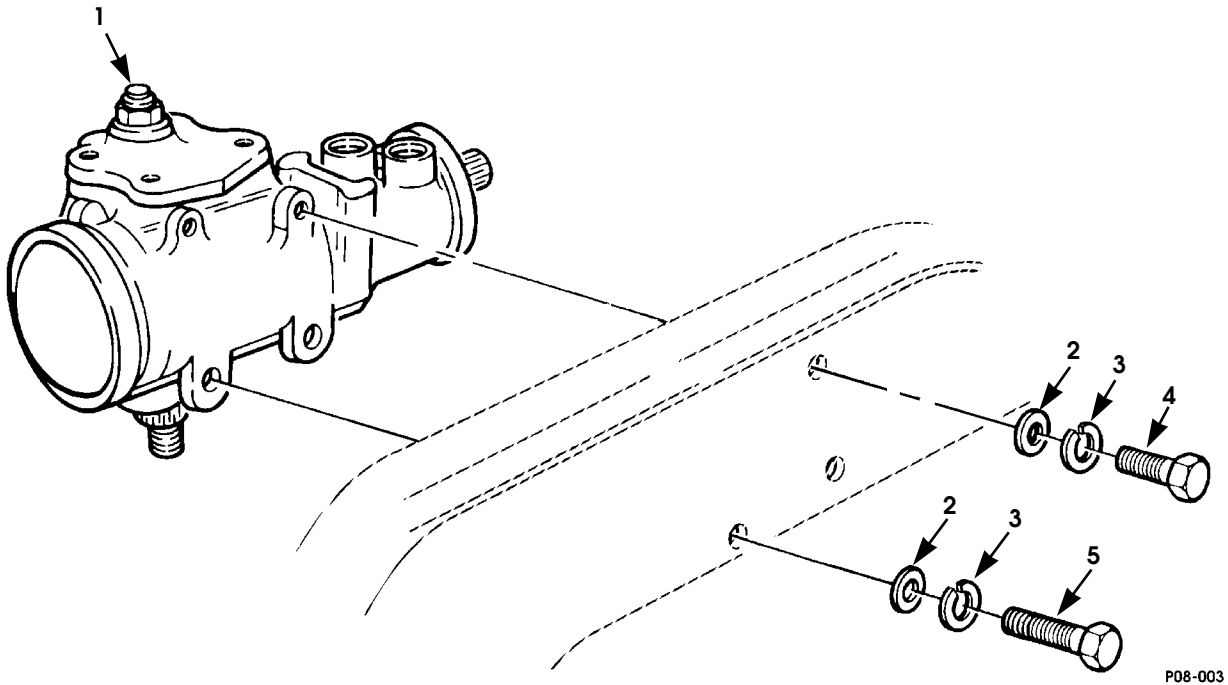

P08-003

Figure 8-5. Power Steering Gear and Mounting Hardware.

# 2001 HUMMER PARTS CATALOG

## STEERING SYSTEM 8-11

ITEM	PART NUMBER	DESCRIPTION	QTY
		<b>Figure 8-5. Power Steering Gear and Mounting Hardware.</b>	
1	12460232	STEERING GEAR, power. . . . .	1
2	N/S	WASHER, flat, hard, 7/16, type B, steering gear. . . . .	3
3	N/S	LOCKWASHER, heavy, 7/16, steering gear . . . . .	3
4	N/S	BOLT, 7/16 - 14 x 4, Gr8, Phos, steering gear . . . . .	1
5	N/S	BOLT, 7/16 - 14 x 5 1/4, Gr8, Phos, steering gear . . . . .	2

# 2001 HUMMER PARTS CATALOG

## 8-12 STEERING SYSTEM

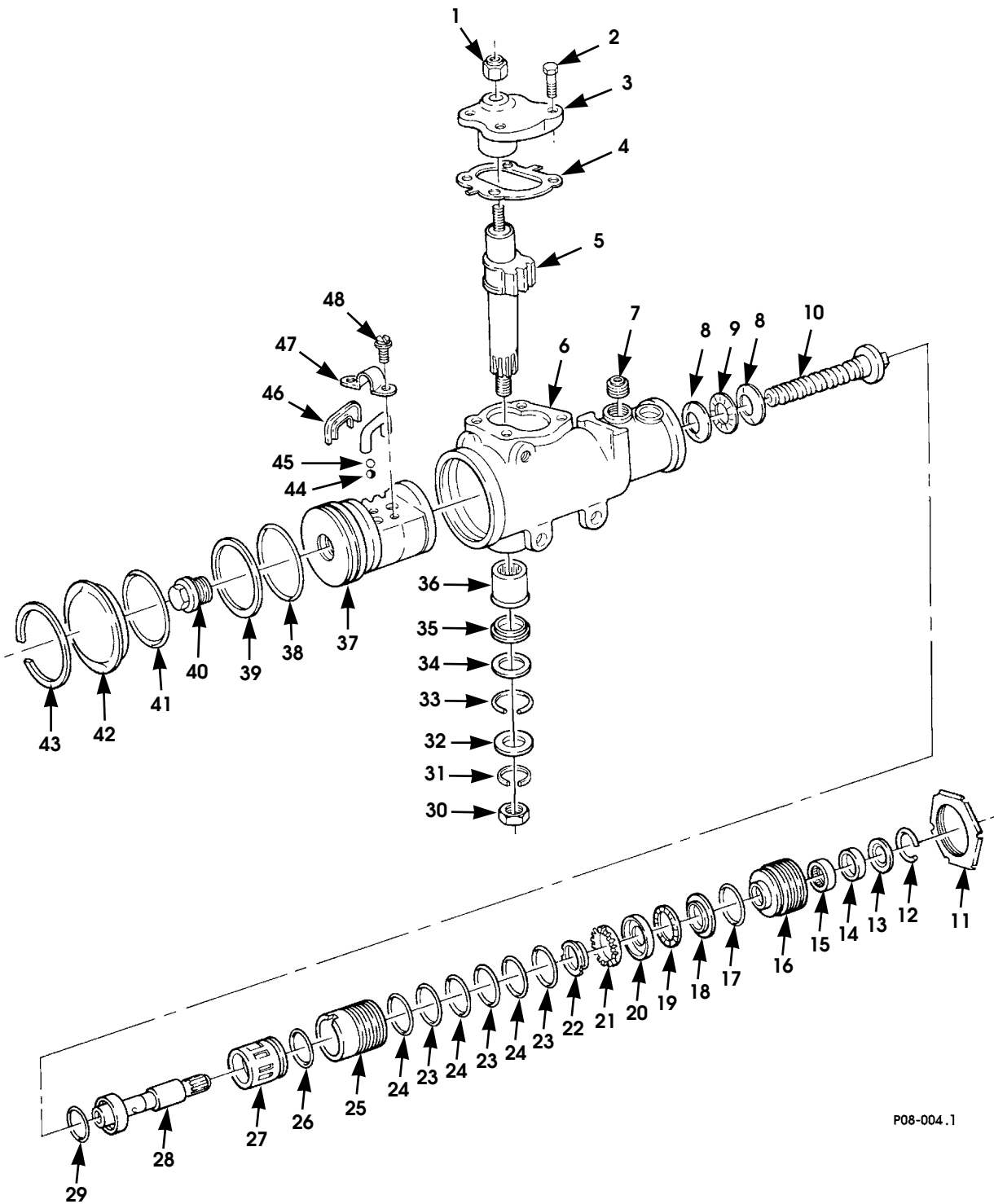

P08-004.1

Figure 8-6. Power Steering Gear Assembly.

# 2001 HUMMER PARTS CATALOG

## STEERING SYSTEM 8-13

ITEM	PART NUMBER	DESCRIPTION	QTY
		<b>Figure 8-6. Power Steering Gear Assembly.</b>	
1	5740444	NUT, lash adjuster, self-locking . . . . .	1
2	5740445	BOLT, cover assembly, SEE NOTES 1, 2, 12, AND 13 . . . .	4
3	S.I.K.	COVER ASSEMBLY, housing side, SEE NOTE 12. . . . .	1
4	5740447	GASKET, housing, cover assembly, SEE NOTES 1, 12, AND 13 . . . . .	1
5	S.I.K.	GEARSHAFT spur, pitman shaft, SEE NOTE 13. . . . .	1
6	S.I.K.	HOUSING, steering gear, SEE NOTE 15 . . . . .	1
7	S.I.K.	VALVE ASSEMBLY, steering gear check, SEE NOTES 3 AND 15 . . . . .	1
8	S.I.K.	THRUST BEARING RACE, lower, SEE NOTE 4 . . . . .	2
9	S.I.K.	RETAINER AND ROLLER, SEE NOTE 4 . . . . .	1
10	S.I.K.	GEAR ASSEMBLY, worm, SEE NOTE 2 . . . . .	1
11	5741145	NUT, adjuster plug . . . . .	1
12	S.I.K.	RETAINING RING, SEE NOTES 5 AND 14 . . . . .	1
13	S.I.K.	SEAL, shaft, SEE NOTES 5 AND 14 . . . . .	1
14	5741704	SEAL, shaft, SEE NOTES 5 AND 14 . . . . .	1
15	5740483	BUSHING, sleeve, shaft, SEE NOTE 5 . . . . .	1
16	S.I.K.	PLUG, adjuster, shaft, SEE NOTE 5 . . . . .	1
17	5740485	PACKING, preformed, adjuster plug, SEE NOTES 5 AND 14 . . . . .	1
18	S.I.K.	RACE, bearing, SEE NOTES 5 AND 6 . . . . .	1
19	S.I.K.	RETAINER AND ROLLER, SEE NOTES 5 AND 6 . . . . .	1
20	S.I.K.	RACE, bearing, SEE NOTES 5 AND 6 . . . . .	1
21	S.I.K.	SPACER, bearing, SEE NOTES 5 AND 6 . . . . .	1
22	S.I.K.	RETAINER, bearing adjuster plug, SEE NOTES 5 AND 6 .	1
23	S.I.K.	RING, seal, valve body, SEE NOTES 7 AND 16 . . . . .	3
24	S.I.K.	PACKING, preformed, valve body, SEE NOTES 7 AND 16 . . . . .	3
25	S.I.K.	VALVE BODY, steering, SEE NOTE 16 . . . . .	1
26	S.I.K.	SEAL, valve spool, SEE NOTES 7 AND 16 . . . . .	1
27	S.I.K.	VALVE SPOOL, direct, shaft, SEE NOTE 16 . . . . .	1
28	S.I.K.	SHAFT, steering column, SEE NOTE 16 . . . . .	1
29	S.I.K.	RING, seal, shaft, SEE NOTES 7 AND 16 . . . . .	1
30	940523	NUT, pitman shaft. . . . .	1
31	5550554	LOCKWASHER, pitman shaft. . . . .	1
32	S.I.K.	RING, retaining, pitman shaft, SEE NOTES 8 AND 15 . . .	1
33	S.I.K.	WASHER, seal, pitman shaft, SEE NOTES 8 AND 15 . . . .	2
34	S.I.K.	SEAL, pitman shaft, SEE NOTES 8 AND 15 . . . . .	1
35	5740451	SEAL, pitman shaft, SEE NOTES 8 AND 15 . . . . .	1
36	5740453	BEARING, roller, pitman shaft, SEE NOTE 15 . . . . .	1

# 2001 HUMMER PARTS CATALOG

## 8-14 STEERING SYSTEM

ITEM	PART NUMBER	DESCRIPTION	QTY
		<b>Figure 8-6.</b> <b>Power Steering Gear Assembly. (Cont'd)</b>	
37	S.I.K.	RACK, piston nut, SEE NOTE 2 . . . . .	1
38	S.I.K.	RING, seal, piston rack, SEE NOTES 2 AND 9 . . . . .	1
39	S.I.K.	GASKET, piston rack, SEE NOTES 2 AND 9 . . . . .	1
40	5740461	PLUG, piston rack, SEE NOTE 2 . . . . .	1
41	S.I.K.	PACKING, preformed, housing end plug, SEE NOTE 10 . . . . .	1
42	5740456	PLUG, housing end. . . . .	1
43	S.I.K.	RING, retaining, housing end plug, SEE NOTE 10. . . . .	1
44	S.I.K.	BALL, bearing, piston rack, SEE NOTES 2 AND 11. . . . .	12
45	S.I.K.	BALL, chrome, .281250 diameter, piston rack, SEE NOTES 2 AND 11 . . . . .	12
46	5740468	GUIDE, ball, piston rack, SEE NOTE 2 . . . . .	2
47	5740467	STRAP, retaining, piston rack ball guide, SEE NOTE 2. . . . .	1
48	5740466	SCREW, retaining strap, SEE NOTE 2 . . . . .	2
49	S.I.K.	LUBRICANT, pitman shaft (not illustrated), SEE NOTE 8	1
		NOTE 1: PART OF SIDE COVER HOUSING SEAL KIT P/N 5740448	
		NOTE 2: PART OF PISTON NUT RACK KIT P/N 5740462	
		NOTE 3: PART OF STEERING KIT P/N 5741190	
		NOTE 4: PART OF LOWER THRUST BEARING KIT P/N 5740476	
		NOTE 5: PART OF ADJUSTER PLUG KIT P/N 5741703	
		NOTE 6: PART OF UPPER THRUST BEARING KIT P/N 5742166	
		NOTE 7: PART OF SEAL VALVE RING KIT P/N 5740499	
		NOTE 8: PART OF PITMAN SHAFT SEAL KIT P/N 5715393	
		NOTE 9: PART OF SEAL RACK PISTON KIT P/N 5740465	
		NOTE 10: PART OF SEAL END PLUG KIT P/N 5740458	
		NOTE 11: PART OF RECIRCULATING BALL KIT P/N 5740470	
		NOTE 12: PART OF STEERING GEAR SIDE COVER KIT P/N 5741910	
		NOTE 13: PART OF PITMAN SHAFT GEAR ASSEMBLY SERVICE KIT P/N 5742626	
		NOTE 14: PART OF ADJUSTER PLUG SEAL KIT P/N 5741892	
		NOTE 15: PART OF GEAR HOUSING ASSEMBLY SERVICE KIT P/N 5742627	
		NOTE 16: PART OF STEERING GEAR VALVE ASSEMBLY KIT P/N 5742625	



# 2001 HUMMER PARTS CATALOG

## 8-16 STEERING SYSTEM

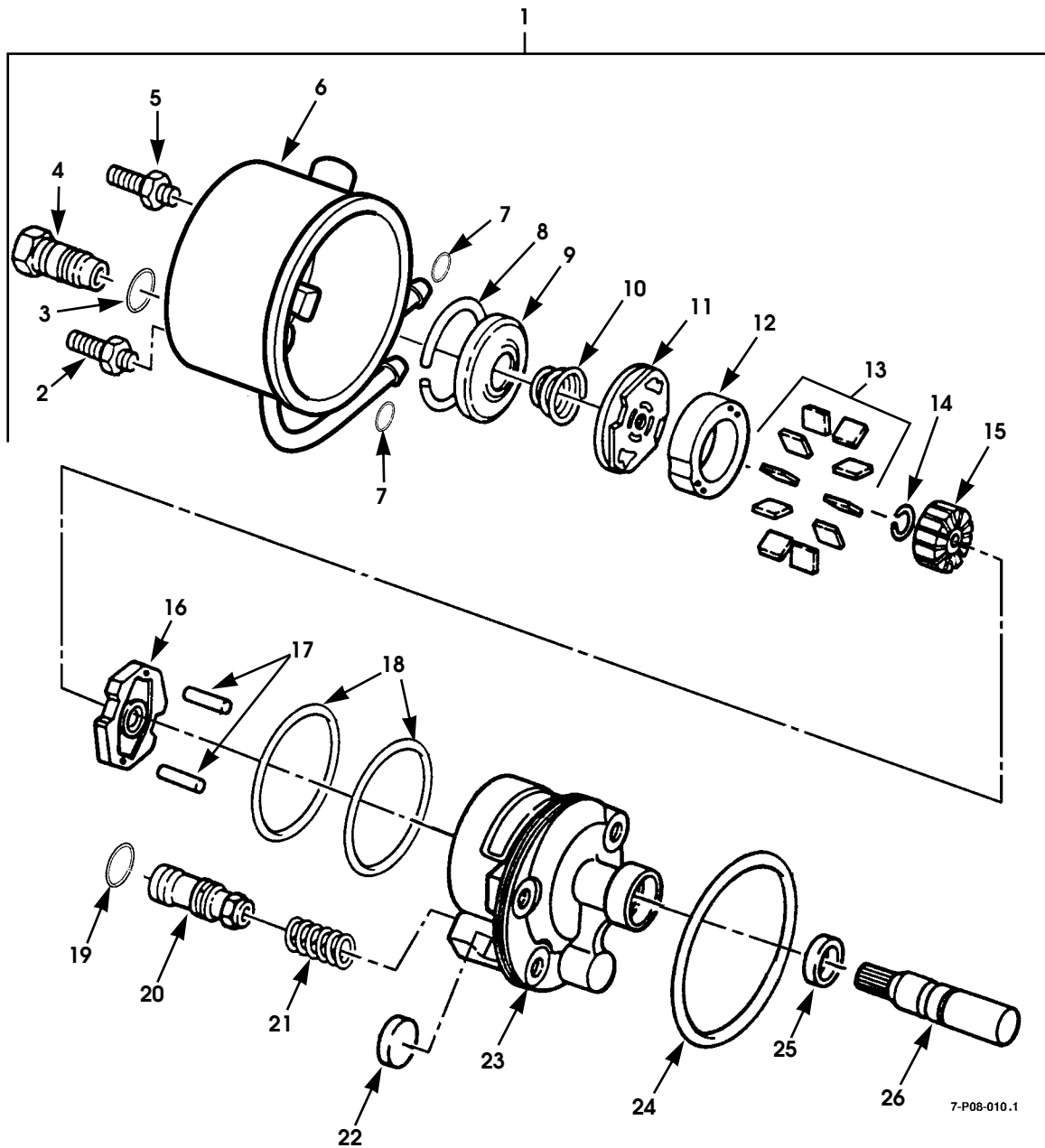

Figure 8-7. Power Steering Pump.

# 2001 HUMMER PARTS CATALOG

## STEERING SYSTEM 8-17

ITEM	PART NUMBER	DESCRIPTION	QTY
		<b>Figure 8-7. Power Steering Pump.</b>	
1	6003042	POWER STEERING PUMP ASSEMBLY . . . . .	1
2	S.I.A.	•STUD, M10 - 1.5 x 15 x 14 with 6mm spacer . . . . .	1
3	S.I.A.	•O-RING, SEE NOTE 1 . . . . .	1
4	S.I.A.	•FITTING . . . . .	1
5	S.I.A.	•STUD, M10 - 1.5 x 15 x 17 . . . . .	1
6	S.I.K.	•HOUSING, power steering pump . . . . .	1
7	S.I.A.	•O-RING, square cut, SEE NOTE 1 . . . . .	2
8	S.I.A.	•RING, retaining . . . . .	1
9	S.I.A.	•END PLATE . . . . .	1
10	S.I.A.	•SPRING, pressure plate . . . . .	1
11	S.I.A.	•PRESSURE PLATE . . . . .	1
12	S.I.A.	•PUMP RING . . . . .	1
13	S.I.A.	•VANES . . . . .	10
14	S.I.A.	•RING, retaining . . . . .	1
15	S.I.A.	•ROTOR, power steering pump . . . . .	1
16	S.I.A.	•PLATE, thrust . . . . .	1
17	S.I.A.	•PIN, dowel . . . . .	2
18	S.I.A.	•O-RING, SEE NOTE 1 . . . . .	2
19	S.I.A.	•O-RING, square cut, SEE NOTE 1 . . . . .	1
20	5741823	•VALVE, flow control . . . . .	1
21	S.I.A.	•SPRING, valve . . . . .	1
22	S.I.A.	•MAGNET, SEE NOTE 1 . . . . .	1
23	S.I.A.	•PUMP BODY, power steering . . . . .	1
24	S.I.A.	•O-RING, SEE NOTE 1 . . . . .	1
25	S.I.A.	•SEAL, high temperature, SEE NOTE 1 . . . . .	1
26	S.I.A.	•DRIVESHAFT . . . . .	1
		NOTE 1: PART OF POWER STEERING PUMP SEAL SERVICE KIT P/N 5740440.	



# 2001 HUMMER PARTS CATALOG

## 8-18 STEERING SYSTEM

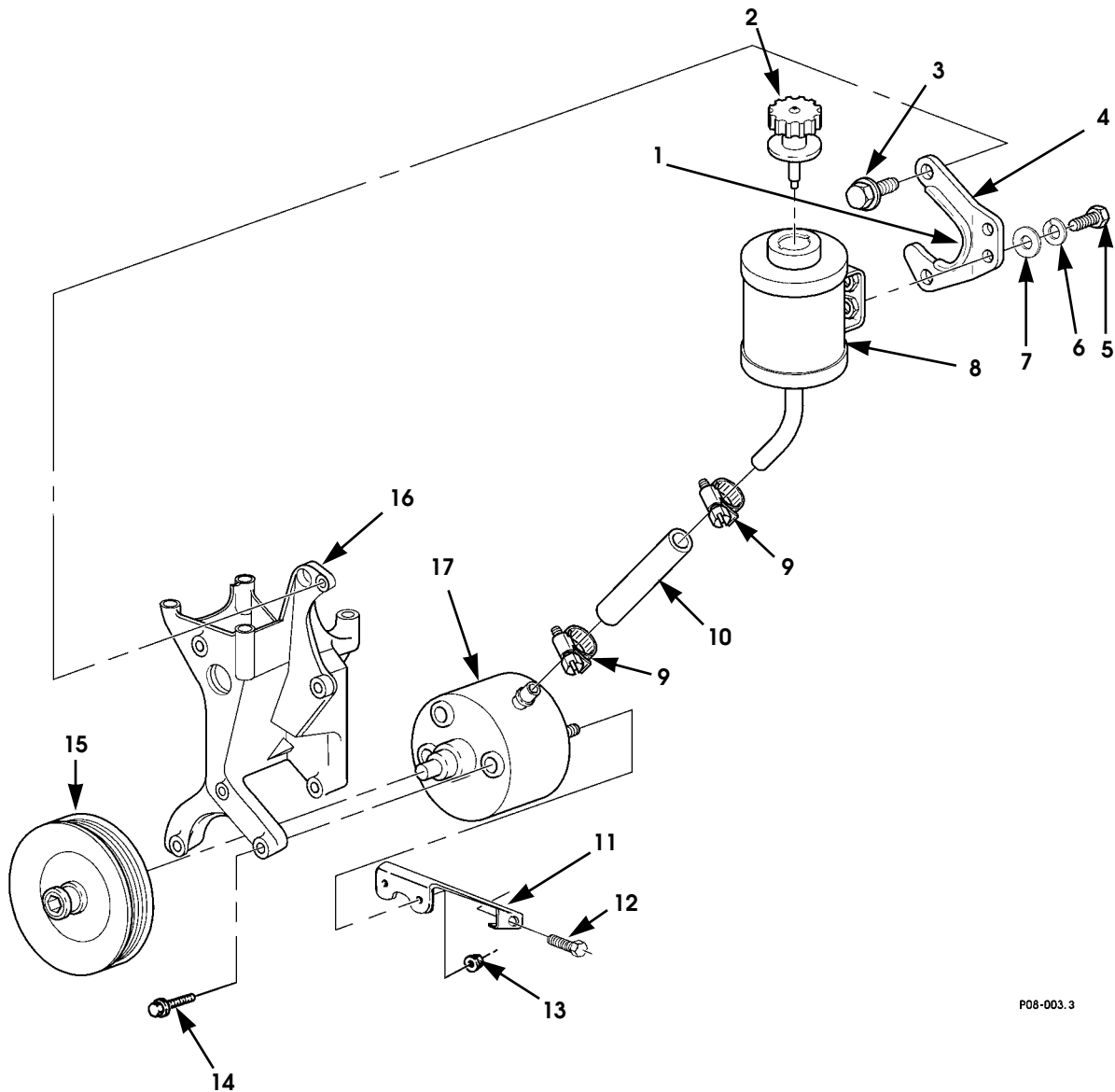

P08-003.3

*Figure 8-8. Power Steering Pump, Pulley, Reservoir, and Mounting Hardware.*

# 2001 HUMMER PARTS CATALOG

## STEERING SYSTEM 8-19

ITEM	PART NUMBER	DESCRIPTION	QTY
		<b>Figure 8-8. Power Steering Pump, Pulley, Reservoir, and Mounting Hardware.</b>	
1	12339902-12	EDGE GUARD, 5 1/2" long. . . . .	1
2	6002106	CAP,power steering reservoir. . . . .	1
3	N/S	BOLT,M10 - 1.5 x 25,flanged,bracket-to-engine. . . . .	2
4	6010662B9	BRACKET,power steering reservoir mounting. . . . .	1
5	N/S	BOLT,M8 - 1.25 x 25,mounting bracket-to-reservoir . . . . .	2
6	N/S	LOCKWASHER,M8 . . . . .	2
7	N/S	WASHER,flat,M8 . . . . .	2
8	6010670	RESERVOIR,power steering . . . . .	1
9	N/S	CLAMP,hose,worm gear,3/4" - 1 1/8" . . . . .	2
10	N/S	HOSE,power steering reservoir-to-pump,7 3/4" long SEE NOTE 1. . . . .	1
11	6006785	BRACE,rear,power steering pump . . . . .	1
12	6006780	BOLT . . . . .	1
13	11503643	NUT . . . . .	2
14	N/S	BOLT,M10 - 1.5 x 35,class 9.8 . . . . .	3
15	6004158	PULLEY,power steering pump . . . . .	1
16	6006807	BRACKET,P/S pump,A/C pump. . . . .	1
17	6003042	PUMP,power steering . . . . .	1
		NOTE 1: CUT FROM P/S RESERVOIR HOSE, P/N 06003166, 1 1/16" O.D. X 3/4" I.D. X 9 1/2" LONG	

# 2001 HUMMER PARTS CATALOG

## 8-20 STEERING SYSTEM

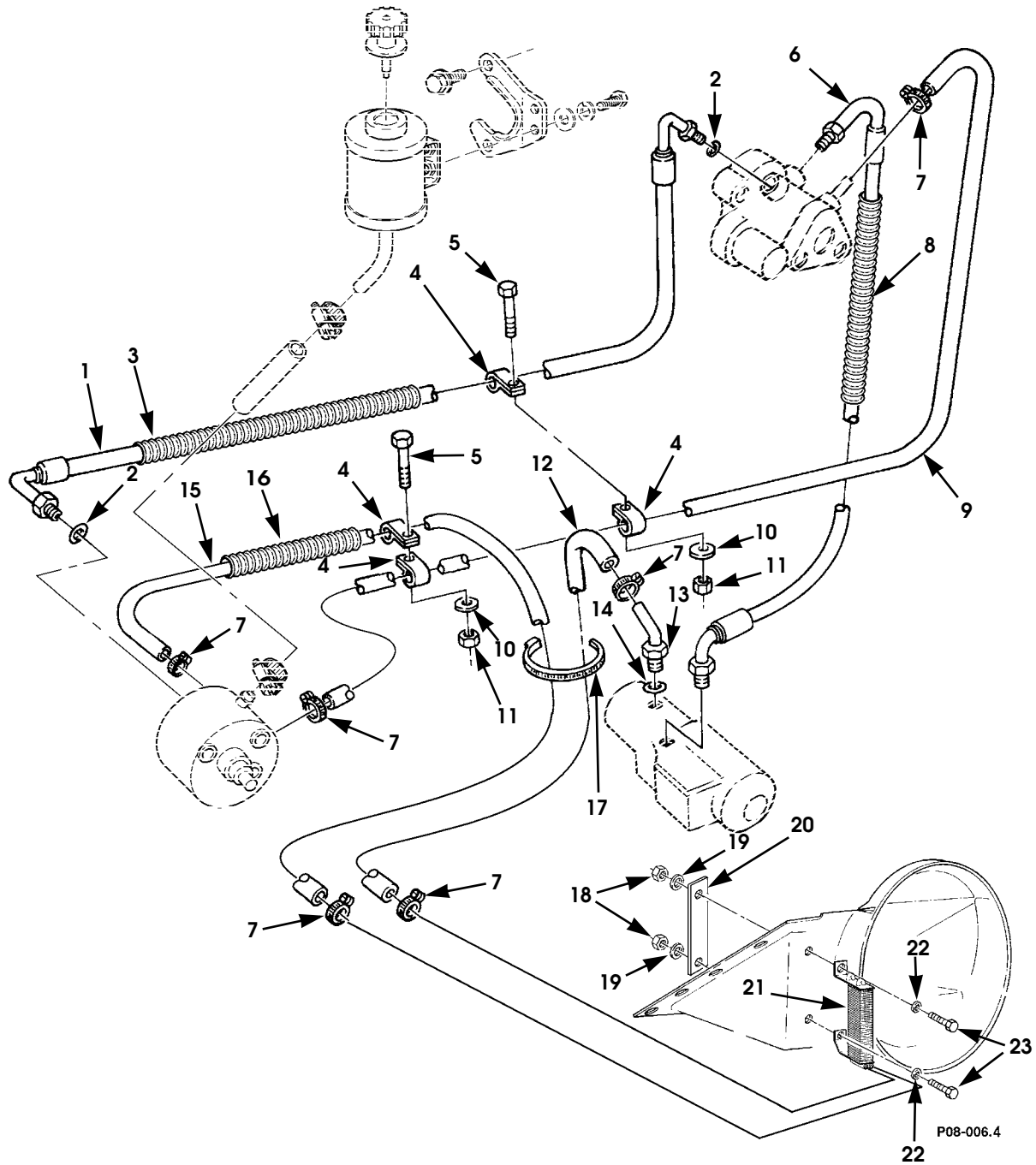

Figure 8-9. Power Steering Pump, Oil Cooler, and Hydro-Boost Lines and Fittings.

# 2001 HUMMER PARTS CATALOG

## STEERING SYSTEM 8-21

ITEM	PART NUMBER	DESCRIPTION	QTY
		<b>Figure 8-9. Power Steering Pump, Oil Cooler, and Hydro-Boost Lines and Fittings.</b>	
1	6009990	HOSE ASSEMBLY, p/s pump-to-Hydro-Boost . . . . .	1
2	N/S	•SEAL, O-ring . . . . .	2
3	N/S	CONVOLUTED CONDUIT, p/s pump-to-Hydro-Boost hose, 16" long, SEE NOTE 1 . . . . .	1
4	N/S	CLAMP, harness, rear 5/8" cushioned . . . . .	4
5	N/S	SCREW, 1/4 - 20 x 3/4, Gr8 CAD . . . . .	2
6	6009989	HOSE ASSEMBLY, Hydro-Boost-to-steering gear . . . . .	1
7	N/S	CLAMP, hose . . . . .	6
8	N/S	CONVOLUTED CONDUIT, Hydro-Boost-to-steering gear hose, 12" long, SEE NOTE 1 . . . . .	1
9	N/S	HOSE, Hydro-Boost-to-p/s pump, 31" long, SEE NOTE 2	1
10	N/S	WASHER, flat, 1/4 . . . . .	2
11	N/S	LOCKNUT, 1/4-20, Gr8 . . . . .	2
12	N/S	HOSE, steering gear-to-cooler, 9.25" long, SEE NOTE 2.	1
13	12338593	TUBE ASSEMBLY. . . . .	1
14	12340395	SEAL, O-ring . . . . .	1
15	N/S	HOSE, cooler-to-power steering pump, 20" long, SEE NOTE 2 . . . . .	1
16	N/S	CONVOLUTED CONDUIT, cooler-to-p/s pump hose, 19 3/4" long, SEE NOTE 3 . . . . .	1
17	OMS3367-2-0	TIEDOWN STRAP. . . . .	1
18	N/S	NUT, 5/16 - 18, Gr5 . . . . .	2
19	N/S	WASHER, flat, 5/16 . . . . .	4
20	6007233	PLATE, backing, P/S cooler . . . . .	1
21	6010082	OIL COOLER ASSEMBLY, P/S . . . . .	1
22	N/S	LOCKWASHER, 5/16 . . . . .	2
23	N/S	SCREW, 5/16 - 18 x 1, Gr5, CAD . . . . .	2
		NOTE 1: MAKE FROM SLIT CONVOLUTED CONDUIT, P/N 6010240, 1" O.D. X 3/4" I.D. X 22" LONG	
		NOTE 2: MAKE FROM BULK HOSE, P/N 5741209, 5/ 8" O.D. X 3/8" I.D. X 25 FEET LONG	
		NOTE 3: MAKE FROM NON-SLIT CONVOLUTED CON- DUIT, P/N 6007446, 1" O.D. X 3/4" I.D. X 46" LONG	



# 2001 HUMMER PARTS CATALOG

## AXLES/SUSPENSION/FRAME 9-1

### Section 9

### AXLES/SUSPENSION/FRAME

TITLE	PAGE NUMBER
Airlift Brackets, Front Spring Seats, and Mounting Hardware . . . . .	9-20
Axle Differential, Mounting Brackets, and Hardware . . . . .	9-38
Axle Differential . . . . .	9-40
Bumper, Front and Lifting Shackle (with Winch) . . . . .	9-28
Bumper, Front and Lifting Shackle (without Winch) . . . . .	9-26
Bumper, Rear and Lifting Shackle . . . . .	9-30
Control Arms, Ball Joints, and Mounting Hardware . . . . .	9-12
Frame Rails, Body Mount Brackets, and Transmission Crossmember . . . . .	9-18
Front Suspension Crossmembers, Related Parts, and Mounting Hardware . . . . .	9-6
Front Upper Control Arm Brackets, L.H. . . . .	9-22
Front Upper Control Arm Brackets, R.H. . . . .	9-24
Geared Hub (Knuckle) Assemblies . . . . .	9-50
Halfshaft Assembly, Left and Right Side . . . . .	9-34
Propeller Shafts . . . . .	9-36
Rear Radius Rods . . . . .	9-16
Rear Suspension Crossmembers, Related Parts, and Mounting Hardware . . . . .	9-8
Shock Absorbers and Springs, Front and Rear . . . . .	9-10
Stabilizer Bar and Connecting Links . . . . .	9-14
Upper Control Arm Brackets, Spring Seats, Related Parts, and Mounting Hardware . . . . .	9-32
Vent Lines, Front Axle and Geared Hub . . . . .	9-46
Vent Lines, Rear Axle and Geared Hub . . . . .	9-48

# 2001 HUMMER PARTS CATALOG

## 9-2 AXLES/SUSPENSION/FRAME

PAGE	ITEM	PART NUMBER	DESCRIPTION	QTY
			<b>Complete Frame Assembly (Illustrations on the pages indicated)</b>	
		6010114B9	FRAME ASSEMBLY, complete (not illustrated) . . . . .	1
Various		N/S	•BOLT, 1/2 -13 x 1, Gr8, CAD . . . . .	11
Various		N/S	•BOLT, 1/2 -13 x 1 1/4, Gr8, CAD . . . . .	17
Various		N/S	•BOLT, 1/2 -13 x 1 1/2, Gr8, CAD . . . . .	4
Various		N/S	•BOLT, 1/2 -13 x 1 3/4, Gr8, CAD . . . . .	1
Various		N/S	•BOLT, 1/2 -13 x 2 3/4, Gr8, CAD . . . . .	12
Various		N/S	•BOLT, 1/2 -13 x 3, Gr8, CAD . . . . .	10
Various		N/S	•BOLT, 1/2 -13 x 3 1/4, Gr8, CAD . . . . .	6
Various		N/S	•BOLT, 1/2 -13 x 3 1/2, Gr8, CAD . . . . .	9
Various		N/S	•BOLT, 1/2 -13 x 3 3/4, Gr8, CAD . . . . .	10
Various		N/S	•BOLT, 1/2 -13 x 4 1/4, Gr8, CAD . . . . .	32
Various		N/S	•BOLT, 1/2 -13 x 4 1/2, Gr8, CAD . . . . .	9
Various		N/S	•BOLT, 1/2 -13 x 4 3/4, Gr8, CAD . . . . .	3
Various		N/S	•BOLT, 3/4 - 10 x 3 1/4, Gr8, CAD . . . . .	4
Various		N/S	•BOLT, 3/4 - 10 x 4 1/4, Gr8, CAD . . . . .	16
Various		N/S	•BOLT, 3/4 - 10 x 4 1/2, Gr8, CAD . . . . .	4
Various		N/S	•BOLT, 3/4 - 10 x 4 3/4, Gr8, CAD . . . . .	8
Various		N/S	•BOLT, 5/8 - 11 x 3 1/4, Gr8, CAD . . . . .	2
Various		N/S	•BOLT, 5/8 - 11 x 3 1/2, Gr8, CAD . . . . .	4
9-30	12	12338225-1	•BOLT, 5/8 - 18 x 5 1/2, Gr8, CAD, drilled, rear shackle . . .	2
Various		N/S	•BOLT, 9/16 - 12 x 1 1/2, Gr8, CAD . . . . .	1
9-6, 26	9,7	12338165	•BRACE, front suspension . . . . .	2
9-20, & 22	4,1	WB12342361B5	•BRACKET ASSEMBLY, air lift, L.H. . . . .	1
9-20, & 24	20,1	6003010B5	•BRACKET ASSEMBLY, air lift, R.H. . . . .	1
9-38	12	12342801	•BRACKET ASSEMBLY, axle pinion mounting, front . . . . .	1
9-38	10	12341900	•BRACKET ASSEMBLY, axle pinion mounting, rear . . . . .	1
9-6, 8	12,16	12338146	•BRACKET ASSEMBLY, axle support . . . . .	4
9-18	14	12338178B2	•BRACKET ASSEMBLY, body mount . . . . .	1
3-28, 9-18	34,6	WA12342509B9	•BRACKET ASSEMBLY, C-mount, L.H. . . . .	1
9-18	15	WA12342510B9	•BRACKET ASSEMBLY, C-mount, R.H. . . . .	1
2-28	10	12338205	•BRACKET ASSEMBLY, engine mount and prop shaft, L.H. . .	1
2-28	13	12338163	•BRACKET ASSEMBLY, engine mount, lower R.H. . . . .	1
2-28	12	12338183	•BRACKET ASSEMBLY, engine mount, R.H. . . . .	1
9-38	3	12338150-1	•BRACKET ASSEMBLY, front axle, L.H. . . . .	1
9-38	6	12338150-2	•BRACKET ASSEMBLY, front axle, R.H. . . . .	1
9-26	8	WA123381991B5	•BRACKET ASSEMBLY, front, L.H. . . . .	1
9-26	8	WA123381992B5	•BRACKET ASSEMBLY, front, R.H. . . . .	1
9-20, 22, & 24	9,17,17	N/S	•BRACKET ASSEMBLY, mounting, upr control arm, front. . .	2
9-32	17	N/S	•BRACKET ASSEMBLY, mounting, upr control arm, rear . . .	2

# 2001 HUMMER PARTS CATALOG

## AXLES/SUSPENSION/FRAME 9-3

PAGE	ITEM	PART NUMBER	DESCRIPTION	QTY
			<b>Complete Frame Assembly (Illustrations on the pages indicated)</b>	
9-6	10	EC12338180	•BRACKET ASSEMBLY, radiator . . . . .	1
9-38	6	12338151-1	•BRACKET ASSEMBLY, rear axle, L.H. . . . .	1
9-38	3	12338151-2	•BRACKET ASSEMBLY, rear axle, R.H. . . . .	1
3-18, 9-30	27,16	6006741B5	•BRACKET ASSEMBLY, rear bumper, L.H., inner . . . . .	1
9-30	4	12446989B5	•BRACKET ASSEMBLY, rear bumper, L.H., outer . . . . .	1
3-18, 9-30	27,16	6006749B5	•BRACKET ASSEMBLY, rear bumper, R.H., inner . . . . .	1
9-30	4	12446990B5	•BRACKET ASSEMBLY, rear bumper, R.H., outer . . . . .	1
9-8	7	EC12338197	•BRACKET ASSEMBLY, rear tiedown, forward . . . . .	2
9-8	1	EC12338181	•BRACKET ASSEMBLY, rear tiedown, rear . . . . .	2
9-18	9	EC12338185B9	•BRACKET ASSEMBLY, transmission. . . . .	2
9-20, 22, & 24	7,12,11	6009538B9	•BRACKET ASSEMBLY, upper front control arm . . . . .	4
9-32	4	6009539B9	•BRACKET ASSEMBLY, upper rear control arm . . . . .	4
9-20	15	EC12338173	•BRACKET, front spring . . . . .	1
9-6	7	12338149-1	•BRACKET, front suspension, L.H., front . . . . .	1
9-6	16	12338155-1	•BRACKET, front suspension, L.H., rear . . . . .	1
9-6	7	12338149-2	•BRACKET, front suspension, R.H., front . . . . .	1
9-6	16	12338155-2	•BRACKET, front suspension, R.H., rear . . . . .	1
3-28, 9-18	31,4	EC12338221B9	•BRACKET, muffler hanger . . . . .	1
9-30	7	12342373B5	•BRACKET, rear bumper shackle. . . . .	2
9-8	22	12338148	•BRACKET, rear suspension, rear . . . . .	2
9-8	13	12338224	•BRACKET, rear suspension, front. . . . .	2
9-6	5	12447051	•BRACKET, splash shield . . . . .	2
9-20, & 24	1,6	12338159	•BRACKET, transmission cooling lines . . . . .	1
9-20, & 46	16,20	EC12338170	•BRACKET, vent tube mounting . . . . .	4
9-8, 32, & 48	9,10,13	EC12338172	•BRACKET, vent tube mounting . . . . .	2
9-30	5	6009595B5	•BUMPER ASSEMBLY, rear . . . . .	1
9-18	10	EC12447053B9	•CROSSMEMBER ASSEMBLY, transmission . . . . .	1
9-6	11	12338230	•CROSSMEMBER, front suspension, front . . . . .	1
9-6	13	WB12338223	•CROSSMEMBER, front suspension, rear . . . . .	1
9-8	11	WA12338217	•CROSSMEMBER, rear suspension, front . . . . .	1
9-8	21	WA12338222	•CROSSMEMBER, rear suspension, rear . . . . .	1
9-18	5	5745026B9	•FRAME RAIL ASSEMBLY, L.H. . . . .	1
9-18	1	12338247B9	•FRAME RAIL ASSEMBLY, R.H. . . . .	1
Various		N/S	•LOCKNUT, 1/2 - 13, CAD . . . . .	127
Various		N/S	•LOCKNUT, 3/4 - 10, CAD . . . . .	32
Various		N/S	•LOCKNUT, 5/8 - 11, CAD . . . . .	6
Various		N/S	•NUT, 1/4 - 20, Gr2, ZN. . . . .	4
Various		N/S	•NUT, 9/16 - 12, Gr8 . . . . .	2
9-30	9	272739	•NUT, nylock, 5/8 - 18, Gr8, rear bumper shackle . . . . .	2



# 2001 HUMMER PARTS CATALOG

## 9-4 AXLES/SUSPENSION/FRAME

PAGE	ITEM	PART NUMBER	DESCRIPTION	QTY
			<b>Complete Frame Assembly</b> (Illustrations on the pages indicated)	
9-32	14	EC12338174B1	•PLATE, reinforcement, frame . . . . .	2
9-32	13	12338152	•REINFORCEMENT, frame . . . . .	2
9-32	16	12338738	•SEAT, rear spring . . . . .	2
9-30	11	EC12342354B5	•SHACKLE, rear bumper. . . . .	2
9-20, 22, 24, & 32	13, 13, 10, 8	12338226-1	•SHIM, control arm bracket, 0.060-inch . . . . .	A/R
9-20, 22, 24, & 32	13, 13, 10, 8	12338226-2	•SHIM, control arm bracket, 0.120-inch . . . . .	A/R
9-30	3	12338164	•SPACER, mounting bracket, rear bumper . . . . .	4
9-20, 22, 24, & 32	12, 14, 9, 9	6009543	•SPACER, upper control arm, 0.125" . . . . .	A/R
9-20, 22, 24, & 32	12, 14, 9, 9	6009573	•SPACER, upper control arm, 0.250" . . . . .	A/R
9-20	18	12338191-2	•SPRING SEAT ASSEMBLY, L.H. front. . . . .	1
9-20	18	12338191-1	•SPRING SEAT ASSEMBLY, R.H. front. . . . .	1
5-10, 9-18	9, 17	12447177	•STUD, special, T-case anchor cable . . . . .	1
Various		N/S	•WASHER, flat, 1/2, ZN . . . . .	245
Various		N/S	•WASHER, flat, 9/16, ZN . . . . .	4
Various		N/S	•WASHER, flat, 5/8, ZN . . . . .	12
Various		N/S	•WASHER, flat, 3/4, ZN . . . . .	64
9-30	8	7716721	•WASHER, wave, 5/8, rear shackles. . . . .	2
7-16	4	6010677B9	•BRACKET, w/sensor clip. . . . .	2



# 2001 HUMMER PARTS CATALOG

## 9-6 AXLES/SUSPENSION/FRAME

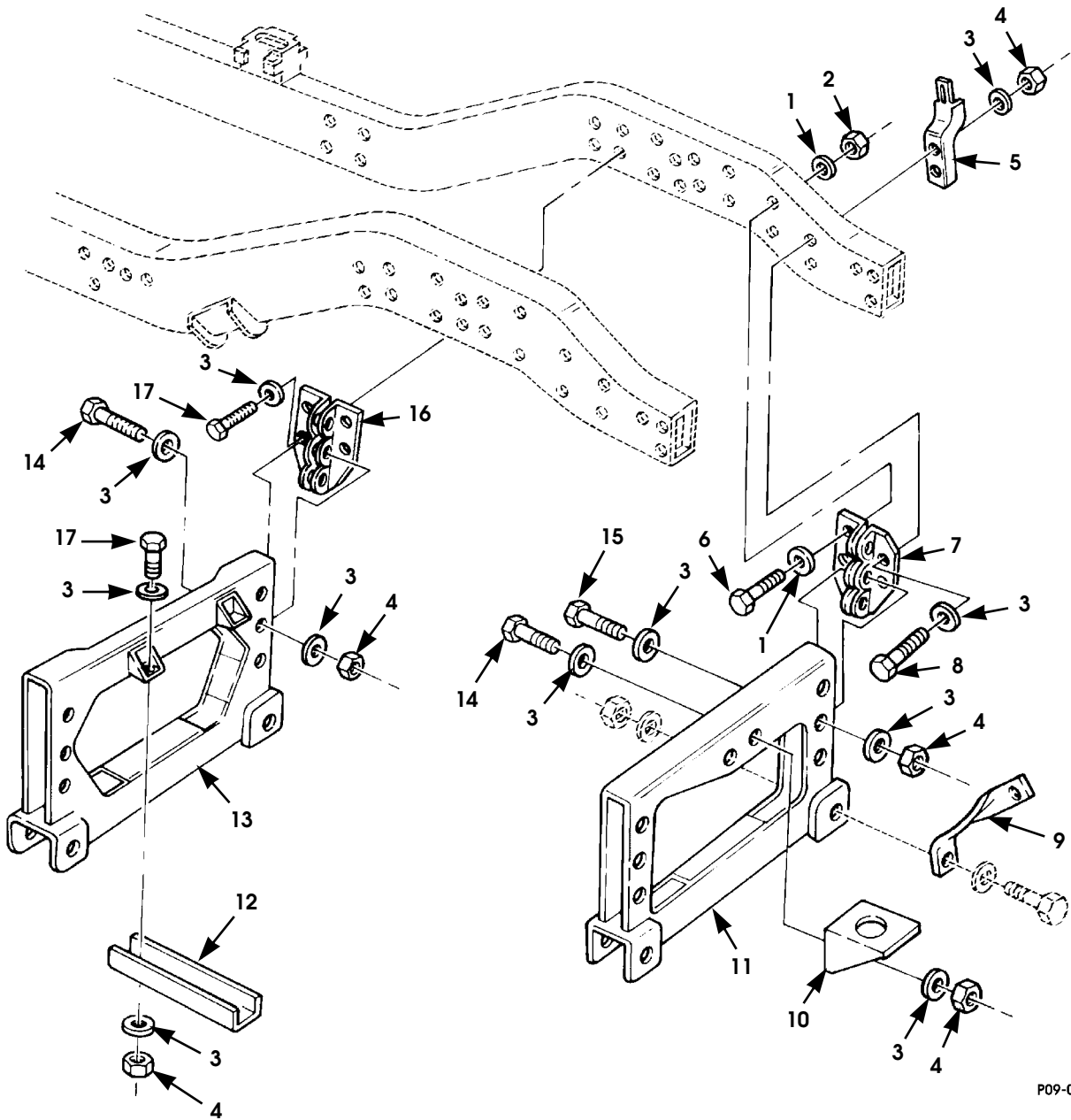

P09-001

Figure 9-1. Front Suspension Crossmembers, Related Parts, and Mounting Hardware.

# 2001 HUMMER PARTS CATALOG

## AXLES/SUSPENSION/FRAME 9-7

ITEM	PART NUMBER	DESCRIPTION	QTY
		<b>Figure 9-1. Front Suspension Crossmembers, Related Parts, and Mounting Hardware.</b>	
1	N/S	WASHER, flat, hard, 3/4, type B . . . . .	8
2	N/S	LOCKNUT, 3/4 - 10, Gr8 . . . . .	4
3	N/S	WASHER, flat, hard, 1/2, type B . . . . .	45
4	N/S	LOCKNUT, 1/2 - 13, Gr8 . . . . .	22
5	12447051	BRACKET, frame assembly, splash shield . . . . .	2
6	N/S	BOLT, 3/4 - 10 x 4, Gr8, CAD . . . . .	4
7	12338149-1	BRACKET, crossmember, L.H., front suspension front . . .	1
7	12338149-2	BRACKET, crossmember, R.H., front suspension front . . .	1
8	N/S	BOLT, 1/2 - 13 x 3 1/4, Gr8, CAD . . . . .	4
9	12338165B5	BRACE, front suspension . . . . .	2
10	12338180	BRACKET, lower radiator mount . . . . .	1
11	12338230	CROSSMEMBER, front forward . . . . .	1
12	12338146	BRACKET, axle support . . . . .	2
13	WB12338223	CROSSMEMBER, front rear . . . . .	1
14	N/S	BOLT, 1/2 - 13 x 3, Gr8, CAD . . . . .	8
15	N/S	BOLT, 1/2 - 13 x 2 3/4, Gr8, CAD . . . . .	6
16	12338155-1	BRACKET, crossmember, L.H., front suspension rear . . .	1
16	12338155-2	BRACKET, crossmember, R.H., front suspension rear . . .	1
17	N/S	BOLT, 1/2 - 13 x 1, Gr8, CAD . . . . .	5

# 2001 HUMMER PARTS CATALOG

## 9-8 AXLES/SUSPENSION/FRAME

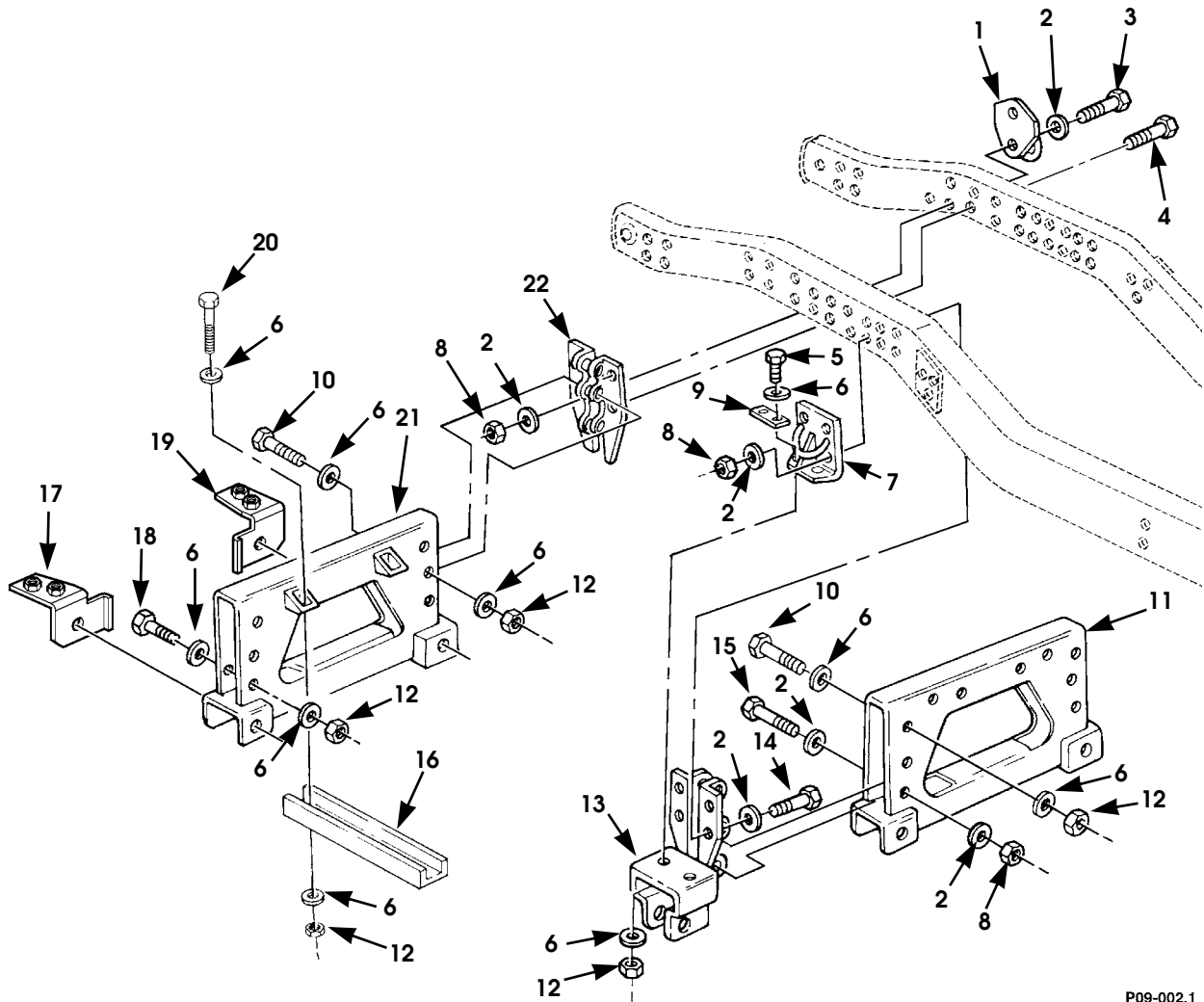

P09-002.1

Figure 9-2. Rear Suspension Crossmembers, Related Parts, and Mounting Hardware

# 2001 HUMMER PARTS CATALOG

## AXLES/SUSPENSION/FRAME 9-9

ITEM	PART NUMBER	DESCRIPTION	QTY
		<b>Figure 9-2. Rear Suspension Crossmembers, Related Parts, and Mounting Hardware</b>	
1	12338181	BRACKET, tiedown, frame assembly . . . . .	2
2	N/S	WASHER, flat, hard, 3/4, type B . . . . .	40
3	N/S	BOLT, 3/4 - 10 x 4 1/4, Gr8, CAD . . . . .	8
4	N/S	BOLT, 3/4 - 10 x 4 3/4, Gr8, CAD . . . . .	4
5	N/S	BOLT, 1/2 - 13 x 1 1/2, Gr8, CAD . . . . .	4
6	N/S	WASHER, flat, hard, 1/2, type B . . . . .	32
7	12338197	BRACKET, tiedown, frame assembly . . . . .	2
8	N/S	LOCKNUT, 3/4 - 10, Gr8 . . . . .	20
9	12338172	BRACKET, vent lines, tube mounting . . . . .	2
10	N/S	BOLT, 1/2 - 13 x 2 3/4, Gr8, CAD . . . . .	6
11	WA12338217	CROSSMEMBER, rear suspension, front . . . . .	1
12	N/S	LOCKNUT, 1/2 - 13, Gr8 . . . . .	18
13	12338224	BRACKET, crossmember, rear suspension . . . . .	2
14	N/S	BOLT, 3/4 - 10 x 4 1/2, Gr8, CAD . . . . .	4
15	N/S	BOLT, 3/4 - 10 x 3 1/4, Gr8, CAD . . . . .	4
16	12338146	BRACKET, rear axle support . . . . .	2
17	6007694	BRACKET ASSEMBLY, mounting, R.H., SEE NOTE 1 . . . . .	1
18	N/S	BOLT, 1/2 - 13 x 3, Gr8, CAD . . . . .	2
19	6007693	BRACKET ASSEMBLY, mounting, L.H., SEE NOTE 1 . . . . .	1
20	N/S	BOLT, 1/2 - 13 x 1, Gr8, CAD . . . . .	4
21	WA12338222	CROSSMEMBER, rear suspension, rear . . . . .	1
22	12338148	BRACKET, crossmember, rear suspension . . . . .	2
		 NOTE 1: USED WITH TRAILER TOWING RECEIVER	

# 2001 HUMMER PARTS CATALOG

## 9-10 AXLES/SUSPENSION/FRAME

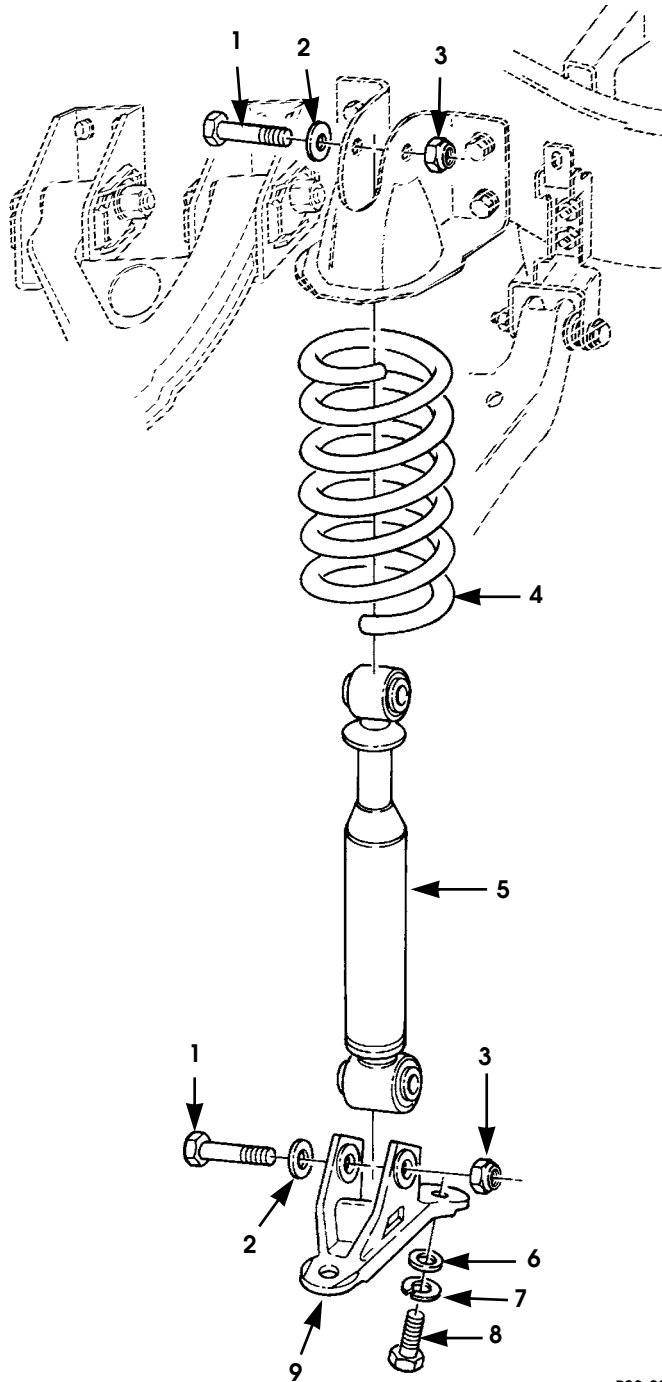

P09-003.1

Figure 9-3. Shock Absorbers and Springs, Front and Rear.

# 2001 HUMMER PARTS CATALOG

## AXLES/SUSPENSION/FRAME 9-11

ITEM	PART NUMBER	DESCRIPTION	QTY
		<b>Figure 9-3. Shock Absorbers and Springs, Front and Rear.</b>	
1	12339205	PIN, shock absorber . . . . .	8
2	N/S	WASHER, flat, hard, 1, type B. . . . .	8
3	12339206	LOCKNUT, shock absorber . . . . .	8
4	12342616B9	SPRING, rear, variable rate, standard . . . . .	2
4	6006008B9	SPRING, rear, 2300 lbs/inch, heavy duty, SEE NOTE 1 . .	2
4	6011073	SPRING, rear, 3000 lbs/inch, heavy duty, SEE NOTE 2 . .	2
4	12338316-1B2	SPRING, front, 954 lbs/inch, standard . . . . .	2
		89	
4	6005787B9	SPRING, front, 954 lbs/inch, extended height, SEE NOTE 3 83, 84, 90	2
4	6005786B9	SPRING, front, 1250 lbs/inch, heavy duty, SEE NOTE 4. .	2
4	6011072	SPRING, front, 1728 lbs/inch, heavy duty, SEE NOTE 5. .	2
5	12340071	SHOCK ABSORBER, front . . . . .	2
5	5937865	SHOCK ABSORBER, front, 12,100-lb GVW . . . . .	2
5	12340072	SHOCK ABSORBER, rear . . . . .	2
6	N/S	WASHER, flat, hard, 5/8 . . . . .	8
7	N/S	LOCKWASHER, med, 5/8, ZN. . . . .	8
8	N/S	BOLT, 5/8 - 11 x 2, Gr8, CAD. . . . .	8
9	12338315	BRACKET, shock absorber mount, lower control arm .	4
		NOTE 1: STANDARD ON 10,800-LB	
		NOTE 2: USED ON 12,100-LB GVW VEHICLES	
		NOTE 3: USED ON 10,300-LB GVW 2-DOOR VEHICLES WITH WINCH; AND ON VEHICLES (MODELS 83, 84, 90) WITHOUT WINCH OR HEAVY FRONT- END EQUIPMENT	
		NOTE 4: USED ON 10,300-LB GVW 4-DOOR VEHICLES (MODELS 83, 84, 90) WITH WINCH	
		NOTE 5: USED ON 10,800-LB & 12,100-LB GVW VEHI- CLES; ON FIRE TRUCKS; AND ON ALL VEHICLES WITH SNOW PLOW.	



# 2001 HUMMER PARTS CATALOG

## 9-12 AXLES/SUSPENSION/FRAME

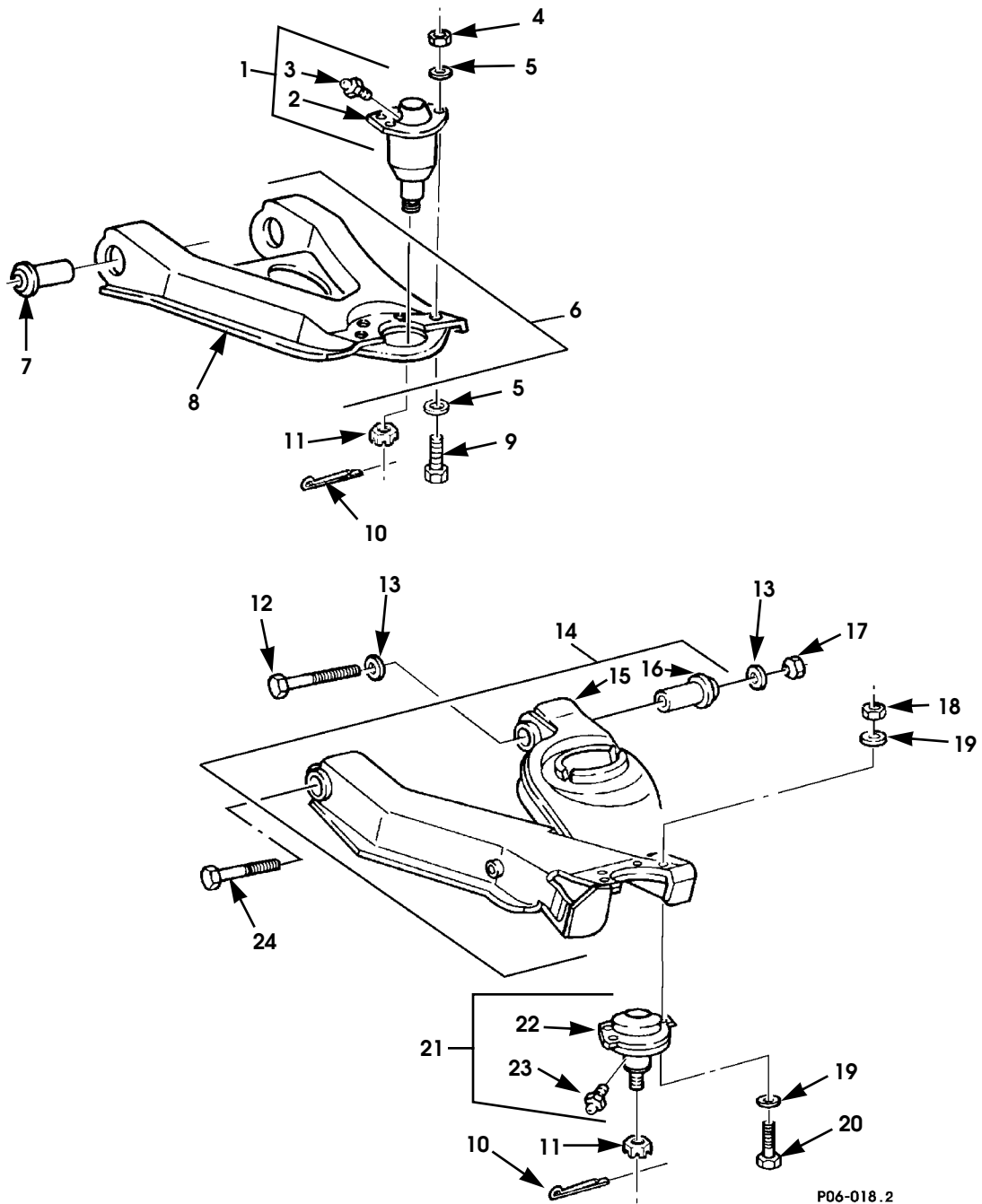

Figure 9-4. Control Arms, Ball Joints, and Mounting Hardware.

# 2001 HUMMER PARTS CATALOG

## AXLES/SUSPENSION/FRAME 9-13

ITEM	PART NUMBER	DESCRIPTION	QTY
		<b>Figure 9-4. Control Arms, Ball Joints, and Mounting Hardware.</b>	
1	6007755	BALL JOINT ASSEMBLY, upper . . . . .	1
2	S.I.A.	•BALL JOINT, upper . . . . .	1
3	9417901	•FITTING, upper ball joint . . . . .	1
4	N/S	LOCKNUT, 3/4 - 10, Gr8 . . . . .	4
5	N/S	WASHER, flat, hard, 3/8, type B . . . . .	8
6	12460167	CONTROL ARM ASSEMBLY, front L.H., upper . . . . .	1
6	12460151	CONTROL ARM ASSEMBLY, front R.H., upper . . . . .	1
6	RCSK17089-1B1	CONTROL ARM ASSEMBLY, rear L.H., upper. . . . .	1
6	RCSK17089-2B1	CONTROL ARM, ASSEMBLY rear R.H., upper,. . . . .	1
7	12338270	•BUSHING, control arm . . . . .	2
8	S.I.A.	•CONTROL ARM, upper . . . . .	1
9	12460159	BOLT, ball joint . . . . .	4
10	N/S	COTTER PIN, ball joint, 1/8" x 1 1/4", CAD . . . . .	1
11	N/S	NUT, castle, 5/8 - 18, Gr8, CAD, ball joint . . . . .	1
12	N/S	BOLT, 3/4 - 10 x 5, Gr8, CAD. . . . .	1
13	N/S	WASHER, flat, 3/4, type B, hard . . . . .	1
14	ECRCSK17249B1	CONTROL ARM, lower front R.H. . . . .	1
14	ECRCSK17250B1	CONTROL ARM, lower front, L.H. . . . .	1
14	ECRCSK17249B1	CONTROL ARM, lower rear, L.H. . . . .	1
14	ECRCSK17250B1	CONTROL ARM, lower rear, R.H. . . . .	1
15	S.I.A.	•CONTROL ARM, lower . . . . .	1
16	S.I.A.	•BUSHING, control arm . . . . .	2
17	N/S	LOCKNUT, 3/4 - 10 . . . . .	4
18	N/S	LOCKNUT, 7/16 - 14, Gr8, CAD . . . . .	4
19	N/S	WASHER, 7/16 - 14, type B, hard . . . . .	8
20	N/S	BOLT, 7/16 - 14 x 1 1/2, Gr8, CAD, control arm mounting. . . . .	4
21	6006645	BALL JOINT ASSEMBLY, lower. . . . .	1
22	S.I.A.	•BALL JOINT, lower. . . . .	1
23	9417901	•FITTING, ball joint . . . . .	1
24	N/S	BOLT, 3/4 - 10 x 3/4, Gr8, CAD . . . . .	1

# 2001 HUMMER PARTS CATALOG

## 9-14 AXLES/SUSPENSION/FRAME

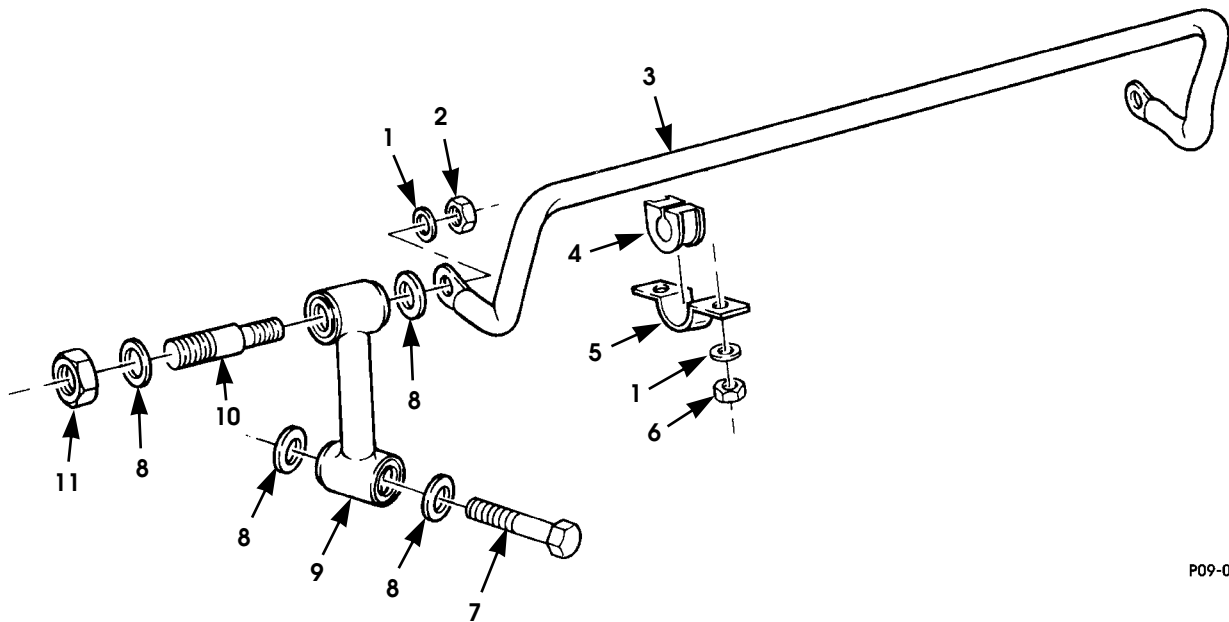

P09-004

Figure 9-5. Stabilizer Bar and Connecting Links.

# 2001 HUMMER PARTS CATALOG

## AXLES/SUSPENSION/FRAME 9-15

ITEM	PART NUMBER	DESCRIPTION	QTY
		<b>Figure 9-5. Stabilizer Bar and Connecting Links.</b>	
1	N/S	WASHER, flat, hard, 1/2, type B . . . . .	6
2	N/S	LOCKNUT, 1/2 - 20, Gr8, CAD . . . . .	2
3	6004872	BAR, stabilizer . . . . .	1
4	12338317	BUSHING, stabilizer bar . . . . .	2
5	12338319	BRACKET, stabilizer bar . . . . .	2
6	N/S	NUT, 7/16 - 14, Gr8, CAD . . . . .	4
7	N/S	BOLT, 5/8 - 11 x 3, Gr8, CAD . . . . .	2
8	12338322	WASHER, flat, connecting link, stabilizer bar . . . . .	8
9	12338323	CONNECTING LINK, stabilizer bar . . . . .	2
10	12339207	PIN, stabilizer bar . . . . .	2
11	N/S	LOCKNUT, 5/8 - 11, Gr8 . . . . .	2

# 2001 HUMMER PARTS CATALOG

## 9-16 AXLES/SUSPENSION/FRAME

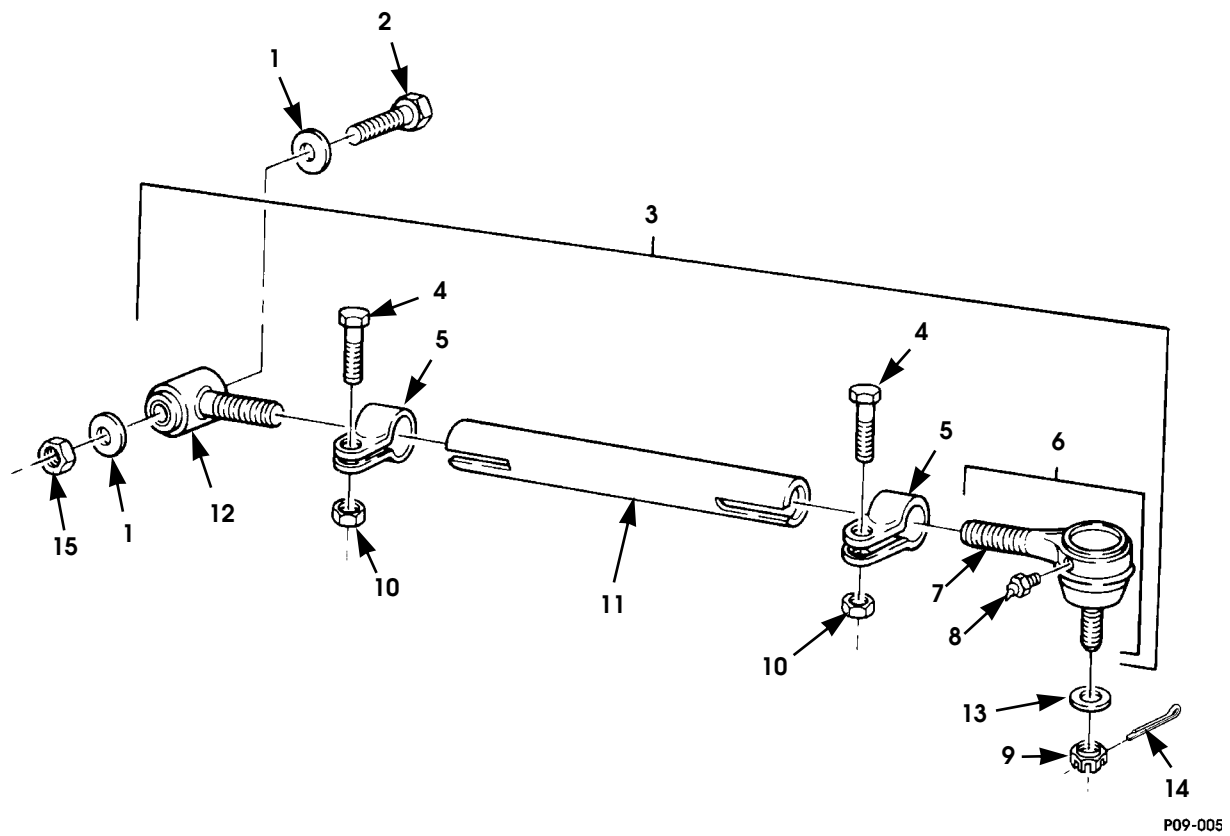

Figure 9-6. Rear Radius Rods.

# 2001 HUMMER PARTS CATALOG

## AXLES/SUSPENSION/FRAME 9-17

ITEM	PART NUMBER	DESCRIPTION	QTY
		<b>Figure 9-6. Rear Radius Rods.</b>	
1	N/S	WASHER, flat, hard, 3/4, type B . . . . .	4
2	N/S	BOLT, 3/4 - 10 x 4 3/4, Gr8, CAD . . . . .	2
3	6005274B1	ROD ASSEMBLY, radius rear . . . . .	2
4	N/S	•BOLT, 7/16 - 14 x 1 3/4, Gr5, Phos. . . . .	2
5	12339202	•CLAMP, rod assembly, retaining . . . . .	2
6	12338311-1	•TIE ROD END ASSEMBLY, L.H. thread . . . . .	1
7	S.I.A.	••TIE ROD END, LH thread . . . . .	1
8	MS15001-3	••FITTING, tie rod end, 45 degree . . . . .	1
9	N/S	••NUT, 5/8 - 18, Gr8, CAD . . . . .	1
10	N/S	•NUT, 7/16 - 14, Gr8, CAD . . . . .	2
11	6005273B9	•ROD ASSEMBLY, rear radius . . . . .	1
12	12338314	•BUSHING, tie rod . . . . .	1
13	N/S	WASHER, 5/8, hard, type B. . . . .	2
14	N/S	COTTER PIN, 1/8" x 1 1/4", CAD . . . . .	2
15	N/S	LOCKNUT, 3/4 - 10, Gr8 . . . . .	2

# 2001 HUMMER PARTS CATALOG

## 9-18 AXLES/SUSPENSION/FRAME

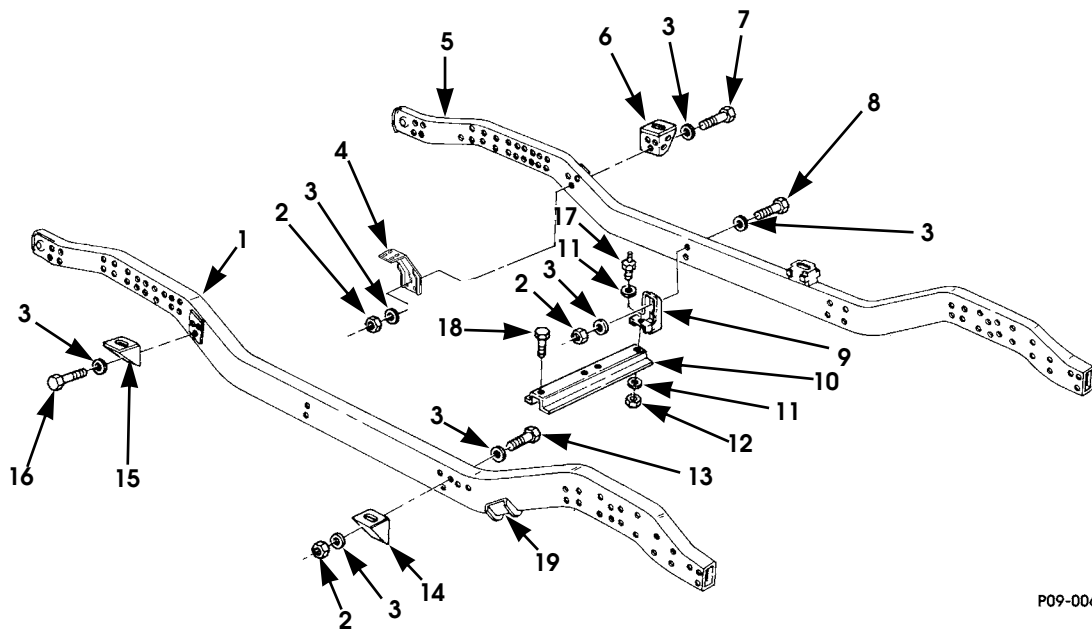

P09-006.2

Figure 9-7. Frame Rails, Body Mount Brackets, and Transmission Crossmember

# 2001 HUMMER PARTS CATALOG

## AXLES/SUSPENSION/FRAME 9-19

ITEM	PART NUMBER	DESCRIPTION	QTY
		<b>Figure 9-7. Frame Rails, Body Mount Brackets, and Transmission Crossmember</b>	
1	12338247B9	RAIL, frame, R.H. . . . .	1
1	RCSK17438	RAIL, frame, R.H., 12,100-lb GVW . . . . .	1
2	N/S	LOCKNUT, 1/2 - 13, Gr8 . . . . .	12
3	N/S	WASHER, flat, hard, 1/2, type B . . . . .	27
4	12338221B9	BRACKET, muffler mounting . . . . .	1
5	5745026B9	RAIL, frame, L.H. . . . .	1
5	RCSK17439	RAIL, frame, L.H., 12,100-lb GVW . . . . .	1
6	WA12342509	BRACKET, body mount, rear, L.H., C-mount. . . . .	1
6	6008610	BRACKET, body mount, rear, L.H., C-mount, 12,100-lb GVW. . . . .	1
7	N/S	BOLT, 1/2 - 13 x 4 3/4, Gr8, CAD, body mount brkt, L.H..	3
8	N/S	BOLT, 1/2 - 13 x 4 1/4, Gr8, CAD, transmission supt brkt	4
9	12338185B9	BRACKET, transmission support . . . . .	2
10	EC12447053B9	CROSSMEMBER, transmission . . . . .	1
11	N/S	WASHER, flat, hard, 9/16, type B . . . . .	4
12	N/S	LOCKNUT, 9/16 - 12, Gr8 . . . . .	2
13	N/S	BOLT, 1/2 - 13 x 4 3/4, Gr8, CAD . . . . .	5
14	12338178B2	BRACKET, body mount, front, R.H. . . . .	1
14	5937399	BRACKET, body mount, front, R.H., 12,100-lb GVW. . . . .	1
15	WA12342510	BRACKET, body mount, rear, R.H., C-mount. . . . .	1
15	5937961	BRACKET, body mount, rear, R.H., C-mount, 12,100-lb GVW . . . . .	1
16	N/S	BOLT, 1/2 - 13 x 1 1/4, Gr8, CAD . . . . .	3
17	12447177	STUD, special, T-case anchor cable, L.H. side only. . . . .	1
18	N/S	BOLT, 9/16 - 12 x 1 1/2, Gr8, ZN. . . . .	1
19	12338132	BRACKET, sway bar mounting . . . . .	1



# 2001 HUMMER PARTS CATALOG

## 9-20 AXLES/SUSPENSION/FRAME

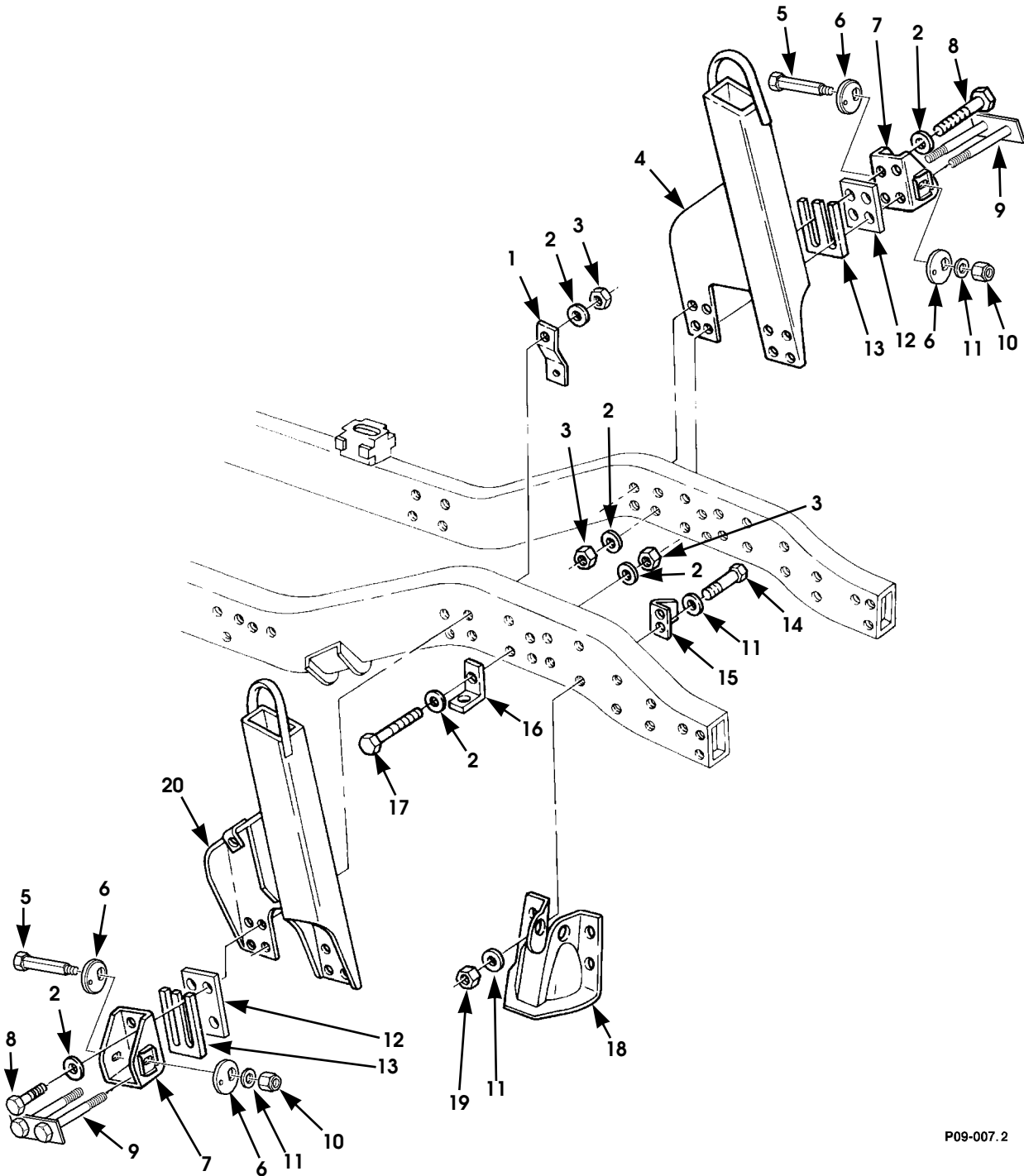

P09-007.2

Figure 9-8. Airlift Brackets, Front Spring Seats, and Mounting Hardware

# 2001 HUMMER PARTS CATALOG

## AXLES/SUSPENSION/FRAME 9-21

ITEM	PART NUMBER	DESCRIPTION	QTY
		<b>Figure 9-8. Airlift Brackets, Front Spring Seats, and Mounting Hardware</b>	
1	12338159	BRACKET, cooling line support . . . . .	1
2	N/S	WASHER, flat, hard, 1/2, type B . . . . .	40
3	N/S	LOCKNUT, 1/2 - 13, Gr8 . . . . .	19
4	WB12342361B5	BRACKET, airlift, L.H. . . . .	1
5	6009807	BOLT, flat-sided, 3/4 - 10 x 5 1/4, control arm mounting	4
6	6009537	CAM, suspension alignment. . . . .	4
7	6009538B9	BRACKET, upper control arm, front . . . . .	4
8	N/S	BOLT, 1/2 - 13 x 4, Gr8, CAD, SEE NOTE 1 . . . . .	15
8	N/S	BOLT, 1/2 - 13 x 3 3/4, Gr8, CAD, SEE NOTE 2 . . . . .	15
9	N/S	BRACKET ASSEMBLY, mounting, front, SEE NOTE 3 . . . . .	2
10	N/S	LOCKNUT, 3/4 - 10 . . . . .	4
11	N/S	WASHER, flat, 3/4, type B . . . . .	16
12	6009543	SPACER, upper control arm mounting bracket, 0.125"	A/R
12	6009573	SPACER, upper control arm mounting bracket, 0.250"	A/R
13	12338226-1	SHIM, upper control arm mounting bracket, 0.060-inch	A/R
13	12338226-2	SHIM, upper control arm mounting bracket, 0.120-inch	A/R
14	N/S	BOLT, 3/4 - 10 x 1/4, Gr8, CAD . . . . .	8
15	12338173	BRACKET, front spring seat . . . . .	1
16	EC12338170	BRACKET, vent tube. . . . .	2
17	N/S	BOLT, 1/2 - 13 x 3 3/4, Gr8, CAD . . . . .	4
18	12338191-1	SPRING SEAT, L.H., front . . . . .	1
18	12338191-2	SPRING SEAT, R.H., front . . . . .	1
19	N/S	LOCKNUT, 3/4 - 10, Gr8 . . . . .	8
20	6003010B5	BRACKET, airlift, R.H. . . . .	1
		NOTE 1: USE WITH 0.240-INCH SHIM PACK AND THICKER	
		NOTE 2: USE WITH SHIM PACK UP TO 0.180-INCH THICK	
		NOTE 3: USE TWO ITEM #8 BOLTS (USE THE SIZE THAT IS CONSISTENT WITH THE SHIM PACK/SPACER COMBINATION) AND TWO ITEM #2 WASHERS TO REPLACE THIS ASSEMBLY.	

# 2001 HUMMER PARTS CATALOG

## 9-22 AXLES/SUSPENSION/FRAME

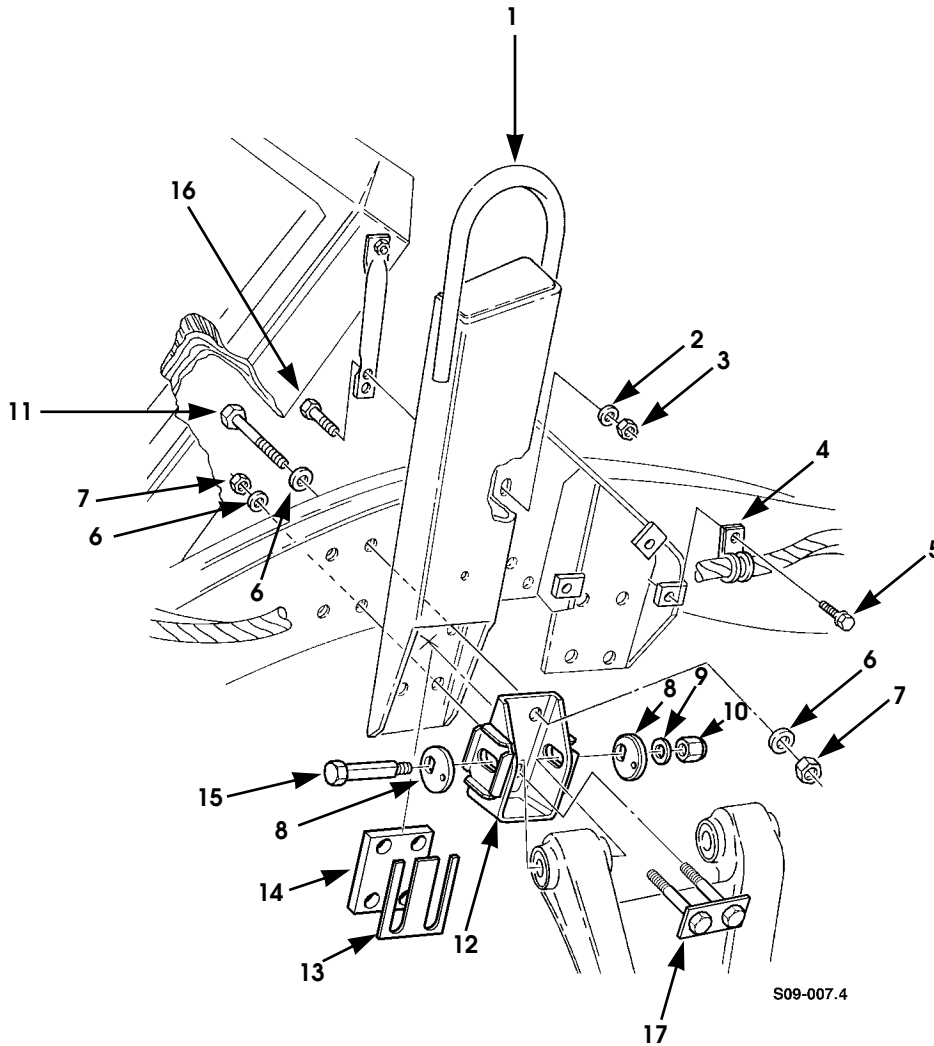

Figure 9-9. Front Upper Control Arm Brackets, L.H.

# 2001 HUMMER PARTS CATALOG

## AXLES/SUSPENSION/FRAME 9-23

ITEM	PART NUMBER	DESCRIPTION	QTY
		<b>Figure 9-9. Front Upper Control Arm Brackets, L.H.</b>	
1	WB12342361B5	BRACKET, air lift, L.H. . . . .	1
2	N/S	WASHER, flat, hardened, 3/8. . . . .	1
3	N/S	LOCKNUT, 3/8 - 16 . . . . .	1
4	N/S	P-CLIP, cushioned, 1/2" . . . . .	3
5	N/S	SCREW, tapping, 1/4 - 20 x 1/2 . . . . .	3
6	N/S	WASHER, flat, hardened, 1/2. . . . .	6
7	N/S	LOCKNUT, 1/2 - 13. . . . .	8
8	6009537	CAM, suspension alignment. . . . .	4
9	N/S	WASHER, flat, hardened, 3/4. . . . .	2
10	N/S	LOCKNUT, 3/4 - 10 . . . . .	2
11	N/S	BOLT, 1/2 - 13 x 3 3/4, Gr8, SEE NOTE 1. . . . .	6
11	N/S	BOLT, 1/2 - 13 x 1 3/4, Gr8, SEE NOTE 2. . . . .	6
12	6009538B9	BRACKET ASSEMBLY, upper control arm mounting, front	2
13	12338226-1	SHIM, upper control arm mounting bracket, 0.060" . .	A/R
13	12338226-2	SHIM, upper control arm mounting bracket, 0.120" . .	A/R
14	6009543	SPACER, upper control arm mounting bracket, 0.125"	A/R
14	6009573	SPACER, upper control arm mounting bracket, 0.250"	A/R
15	6009807	BOLT, flat-sided, 3/4 - 10 x 5 1/4, control arm mounting	2
16	N/S	BOLT, 3/8 - 16 x 1, Gr5, Phos. . . . .	1
17	N/S	BRACKET ASSEMBLY, mounting, front, SEE NOTE 3. . . . .	1
		NOTE 1: USE WITH SHIM PACK/SPACER COMBINATION OF 0.250 INCH OR THICKER	
		NOTE 2: USE WITH SHIM PACK/SPACER COMBINATION OF UP TO 0.240-INCH THICK	
		NOTE 3: USE TWO ITEM #11 BOLTS (USE THE SIZE THAT IS CONSISTENT WITH THE SHIM PACK/SPACER COMBINATION) AND TWO ITEM #6 WASHERS TO REPLACE THIS ASSEMBLY.	

# 2001 HUMMER PARTS CATALOG

## 9-24 AXLES/SUSPENSION/FRAME

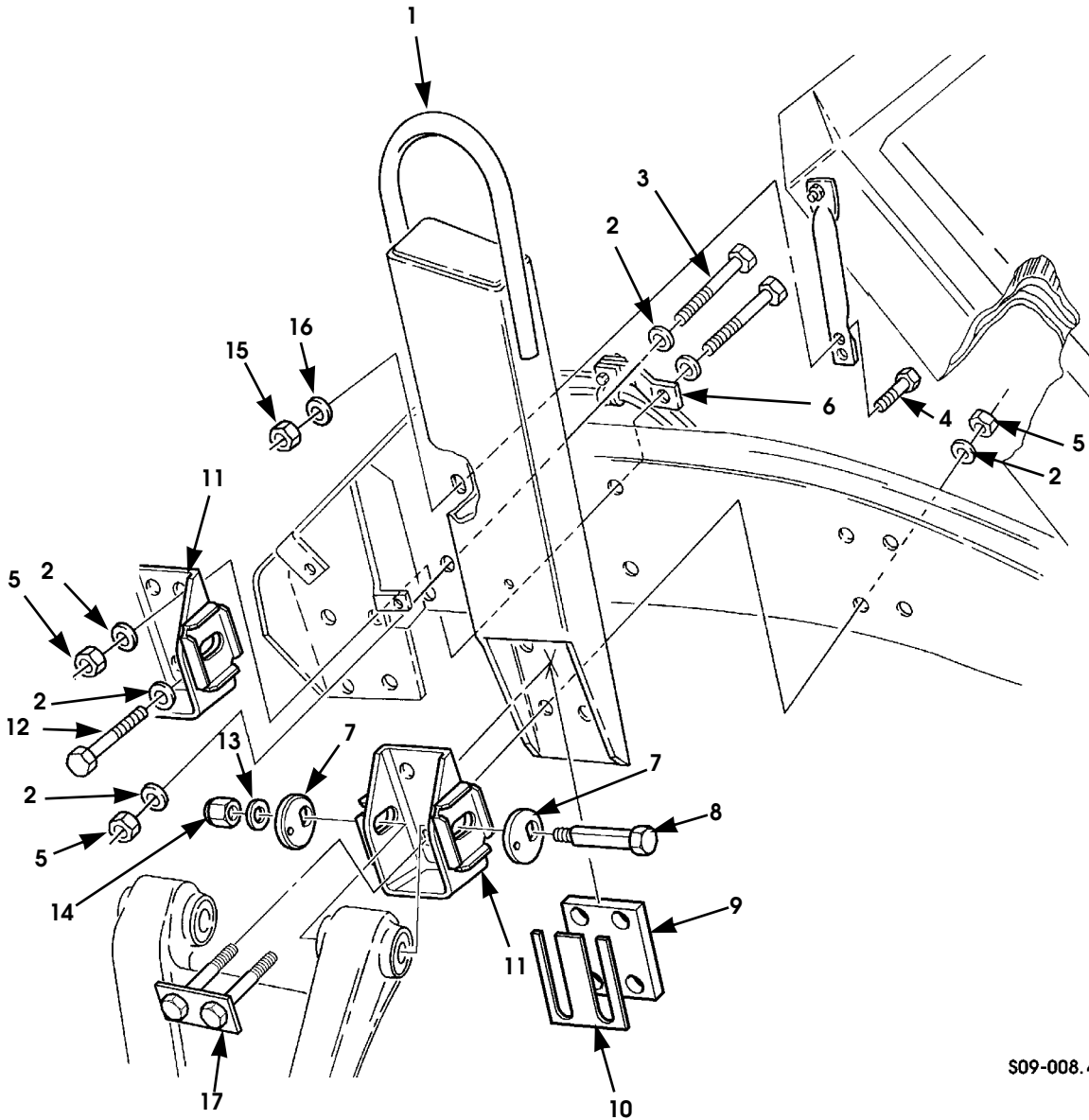

S09-008.4

Figure 9-10. Front Upper Control Arm Brackets, R.H.

# 2001 HUMMER PARTS CATALOG

## AXLES/SUSPENSION/FRAME 9-25

ITEM	PART NUMBER	DESCRIPTION	QTY
		<b>Figure 9-10. Front Upper Control Arm Brackets, R.H.</b>	
1	6003010B5	BRACKET, air lift, R.H. . . . .	1
2	N/S	WASHER, flat, hardened, 1/2, type B . . . . .	16
3	N/S	BOLT, 1/2 - 13 x 4, Gr8, SEE NOTE 1 . . . . .	4
3	N/S	BOLT, 1/2 - 13 x 3 3/4, Gr8, SEE NOTE 2. . . . .	4
4	N/S	BOLT, 3/8 - 16 x 1, Gr5. . . . .	1
5	N/S	LOCKNUT, 1/2 - 13, Gr 8 . . . . .	8
6	12338159	BRACKET, vent line . . . . .	1
7	6009537	CAM, suspension alignment. . . . .	4
8	6009807	BOLT, flat-sided, 3/4 - 10 x 5 1/4, control arm mounting	2
9	6009543	SPACER, upper control arm mounting bracket, 0.125"	A/R
9	6009573	SPACER, upper control arm mounting bracket, 0.250"	A/R
10	12338226-1	SHIM, upper control arm mounting bracket, 0.060" . .	A/R
10	12338226-2	SHIM, upper control arm mounting bracket, 0.120" . .	A/R
11	6009538-B9	BRACKET ASSEMBLY, upper control arm mounting, front	2
12	N/S	BOLT, 1/2 - 13 x 3 3/4, Gr8, SEE NOTE 1. . . . .	6
12	N/S	BOLT, 1/2 - 13 x 1 3/4, Gr8, SEE NOTE 2. . . . .	6
13	N/S	WASHER, flat, hardened, 3/4, type B . . . . .	2
14	N/S	LOCKNUT, 3/4 - 10 . . . . .	2
15	N/S	LOCKNUT, 3/8 - 16, Gr5 . . . . .	1
16	N/S	WASHER, flat, hardened, 3/8, type B . . . . .	1
17	N/S	BRACKET ASSEMBLY, mounting, front, SEE NOTE 3 . . . . .	1
NOTE 1: USE WITH SHIM PACK/SPACER COMBINATION OF 0.250 INCH OR THICKER			
NOTE 2: USE WITH SHIM PACK/SPACER COMBINATION OF UP TO 0.240-INCH THICK			
NOTE 3: USE TWO ITEM #12 BOLTS (USE THE SIZE THAT IS CONSISTENT WITH THE SHIM PACK/SPACER COMBINATION) AND TWO ITEM #2 WASHERS TO REPLACE THIS ASSEMBLY.			

# 2001 HUMMER PARTS CATALOG

## 9-26 AXLES/SUSPENSION/FRAME

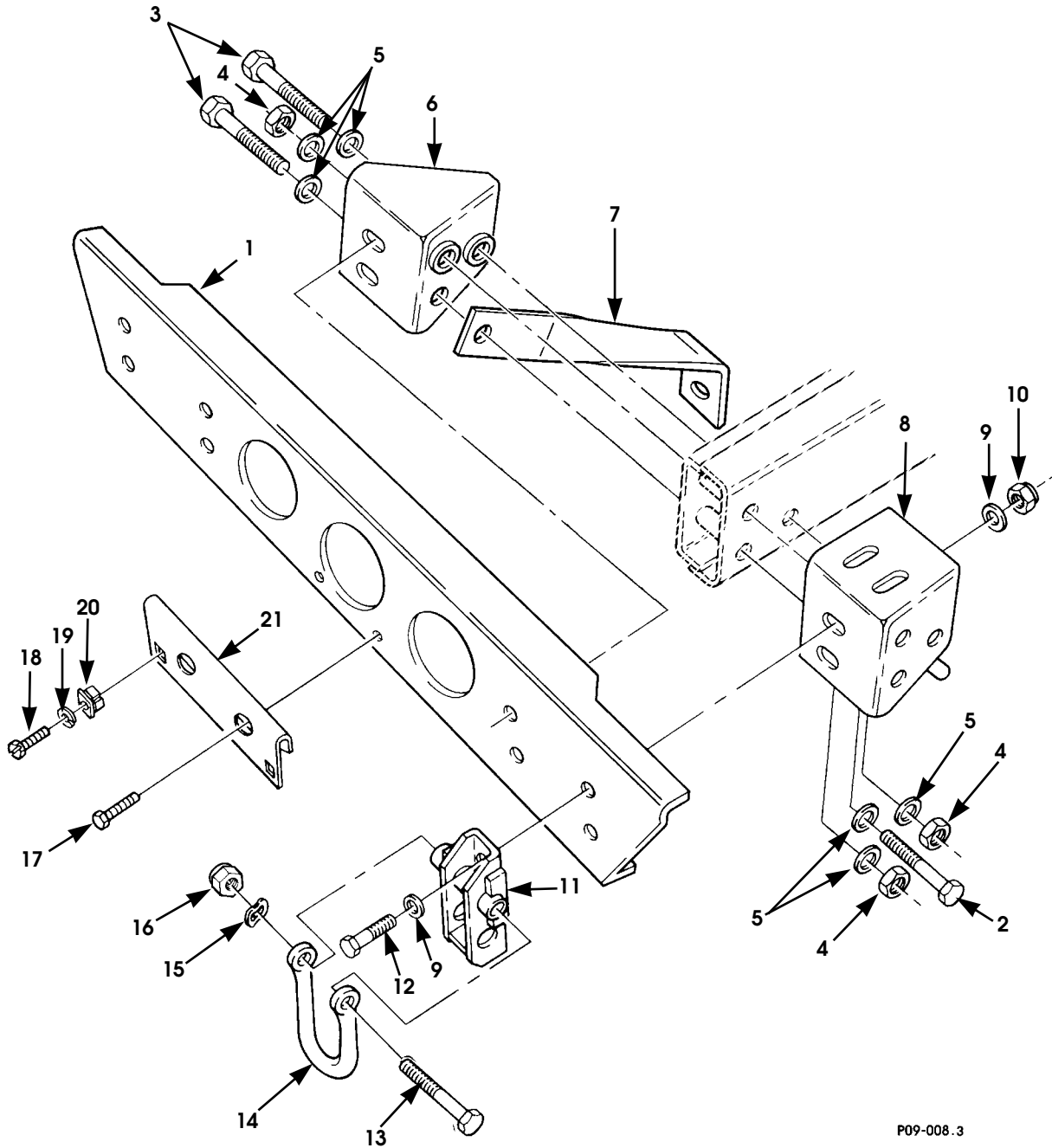

Figure 9-11. Bumper, Front and Lifting Shackle (without Winch).

# 2001 HUMMER PARTS CATALOG

## AXLES/SUSPENSION/FRAME 9-27

ITEM	PART NUMBER	DESCRIPTION	QTY
		<b>Figure 9-11. Bumper, Front and Lifting Shackle (without Winch).</b>	
1	5935800B5	BUMPER, front. . . . .	1
2	N/S	BOLT, 5/8 - 11 x 3 1/4, Gr8, CAD . . . . .	2
3	N/S	BOLT, 5/8 - 11 x 3 1/2, Gr8, CAD . . . . .	4
4	N/S	NUT, 5/8 - 11, Gr8, CAD . . . . .	6
5	N/S	WASHER, flat, hard, 5/8, type B . . . . .	12
6	6001552B5	BRACKET ASSEMBLY, inner, L.H., front bumper, SEE NOTE 1	1
6	6001553B5	BRACKET ASSEMBLY, inner, R.H., front bumper, SEE NOTE 1	1
7	12338165	BRACE, front suspension . . . . .	2
8	WA12338199-1	BRACKET, front bumper, L.H. . . . .	2
8	WA12338199-2	BRACKET, front bumper, R.H. . . . .	2
9	N/S	WASHER, flat, hard, 1/2, type B . . . . .	8
10	N/S	LOCKNUT, 1/2 - 13, Gr8 . . . . .	4
11	12342404B5	BRACKET, towing . . . . .	2
12	N/S	BOLT, 1/2 - 13 x 1 3/4, Gr8, CAD . . . . .	4
13	12338225-1	BOLT, drilled, Gr8 . . . . .	2
14	EC12342354B5	SHACKLE, lifting . . . . .	2
15	7716721	SPRING WASHER, plain, front lifting shackle . . . . .	2
16	N/S	NUT, 5/8 - 18, Gr8, CAD . . . . .	2
17	N/S	SCREW, 1/4 - 20 x 5/8, CAD . . . . .	2
18	N/S	SCREW, 1/4 - 28 x 5/8, ZN, license plate mounting . . . . .	2
19	N/S	LOCKWASHER, 1/4, med, ZN . . . . .	4
20	5939483	GROMMET, square head, license plate bracket . . . . .	2
21	5939482B5	BRACKET, front license plate mounting . . . . .	1
		NOTE 1: FOR USE ONLY WITH BRUSHGUARD AND NO WINCH	



# 2001 HUMMER PARTS CATALOG

## 9-28 AXLES/SUSPENSION/FRAME

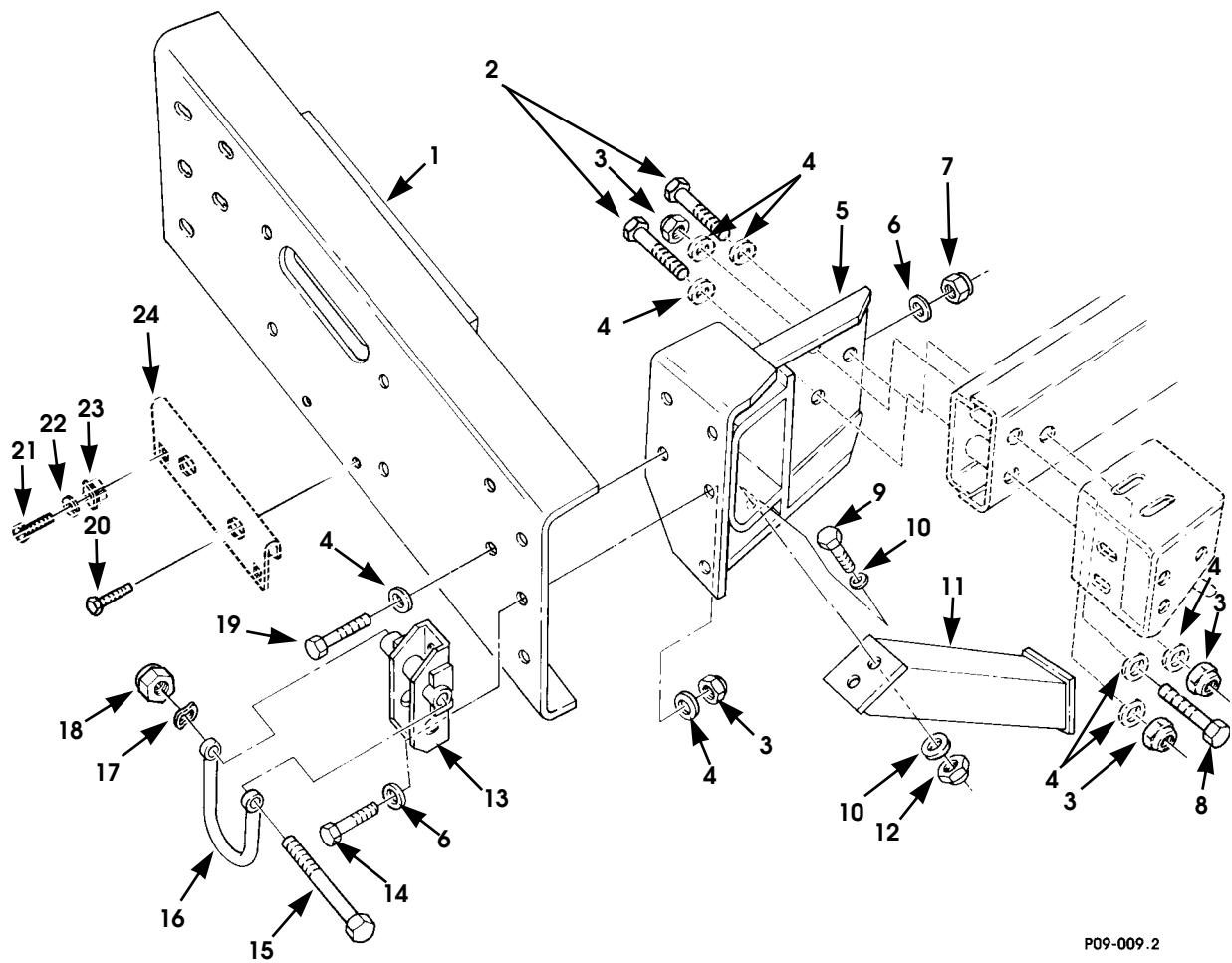

P09-009.2

Figure 9-12. Bumper, Front and Lifting Shackle (with Winch)

# 2001 HUMMER PARTS CATALOG

## AXLES/SUSPENSION/FRAME 9-29

ITEM	PART NUMBER	DESCRIPTION	QTY
		<b>Figure 9-12. Bumper, Front and Lifting Shackle (with Winch)</b>	
1	5935666B5	BUMPER, front, with winch, SEE NOTE 1 . . . . .	1
2	N/S	BOLT, 5/8 - 11 x 3 3/4, Gr8, CAD . . . . .	4
3	N/S	LOCKNUT, 5/8 - 11, Gr8 . . . . .	6
4	N/S	WASHER, flat, hardened, 5/8, type B . . . . .	12
5	12342388B5	FRAME EXTENSION, front bumper, R.H., SEE NOTE 1 . . .	1
5	12342387B5	FRAME EXTENSION, front bumper, L.H., SEE NOTE 1 . . .	1
6	S.I.K.	WASHER, flat, hard, 1/2, type B, SEE NOTE 1 . . . . .	18
7	S.I.K.	LOCKNUT, 1/2 - 13 , front bumper, SEE NOTE 1 . . . . .	8
8	N/S	BOLT, 5/8 - 11 x 3 1/2, Gr8, CAD . . . . .	2
9	S.I.K.	BOLT, 3/8 - 16 x 1, brace assembly, SEE NOTE 1 . . . . .	4
10	S.I.K.	WASHER, flat, 3/8, brace assembly, SEE NOTE 1 . . . . .	8
11	12342389	BRACE ASSEMBLY, L.H., SEE NOTE 1 . . . . .	1
11	12342390	BRACE ASSEMBLY, R.H., SEE NOTE 1 . . . . .	1
12	S.I.K.	NUT, 3/8 - 16, brace assembly, SEE NOTE 1 . . . . .	4
13	12342404B5	BRACKET, towing . . . . .	2
14	N/S	BOLT, 1/2 - 13 x 1 3/4, Gr8, CAD . . . . .	4
15	12338225-1	BOLT, front lifting shackle. . . . .	2
16	EC12342354B9	SHACKLE, lifting . . . . .	2
17	7716721	SPRING WASHER, front lifting shackle. . . . .	2
18	272739	LOCKNUT, nylon insert, 5/8 - 18, Gr8. . . . .	2
19	S.I.K.	BOLT, 1/2 - 13 x 1 1/2, frame extension, SEE NOTE 1 . .	6
20	N/S	BOLT, 1/4 - 20 x 5/8, CAD . . . . .	2
21	N/S	BOLT, 1/4 - 28 x 5/8, ZN. . . . .	2
22	N/S	LOCKWASHER, med, 1/4, ZN . . . . .	2
23	5939483	GROMMET, square head, license plate bracket . . . . .	2
24	5939482B5	BRACKET, front license plate mounting . . . . .	1
		 NOTE 1: PART OF WINCH KIT P/N 5744376	

# 2001 HUMMER PARTS CATALOG

## 9-30 AXLES/SUSPENSION/FRAME

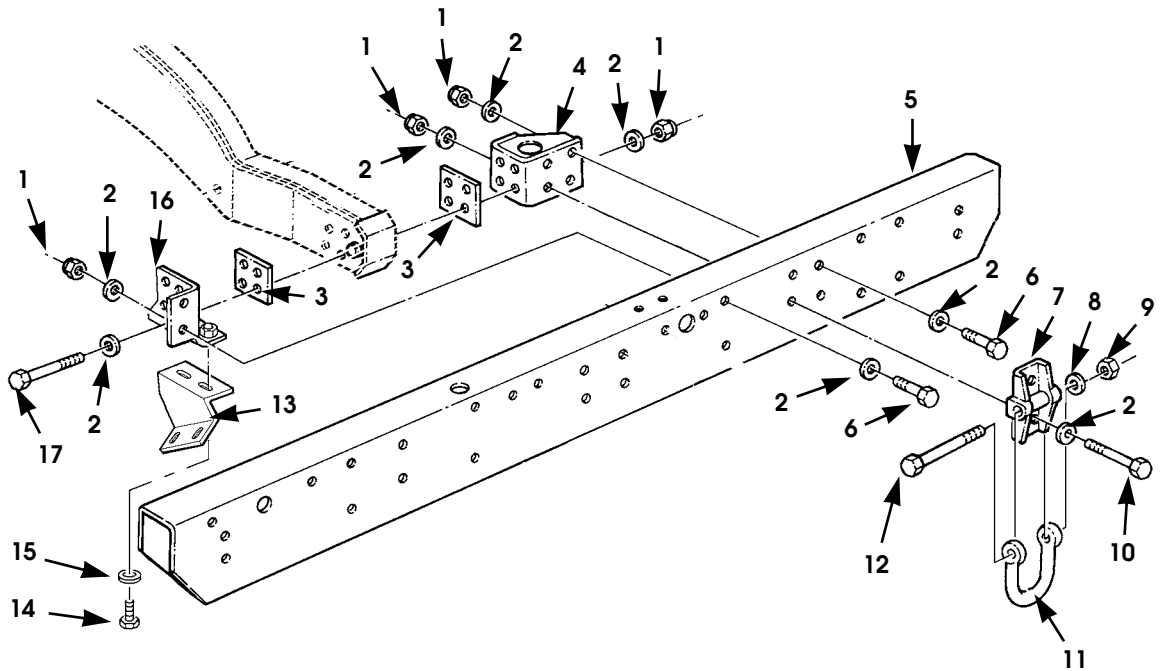

P09-010.2

Figure 9-13. Bumper, Rear and Lifting Shackle

# 2001 HUMMER PARTS CATALOG

## AXLES/SUSPENSION/FRAME 9-31

ITEM	PART NUMBER	DESCRIPTION	QTY
		<b>Figure 9-13. Bumper, Rear and Lifting Shackle</b>	
1	N/S	LOCKNUT, 1/2 - 13, Gr8, rear bumper. . . . .	20
2	N/S	WASHER, flat, hard, 1/2, type B, rear bumper . . . . .	42
3	12338164	SPACER, rear bumper bracket . . . . .	4
4	12446989B5	SUPPORT, rear bumper, L.H. . . . .	1
4	12446990B5	SUPPORT, rear bumper, R.H. . . . .	1
5	6009595B5	BUMPER, rear . . . . .	1
6	N/S	BOLT, 1/2 - 13 x 3 1/2, Gr8, CAD, rear bumper. . . . .	8
7	12342373B5	BRACKET, tiedown . . . . .	2
8	7716721	WASHER, spring, . . . . .	2
9	272739	LOCKNUT, rear lifting shackle . . . . .	2
10	5743671	BOLT, rear bumper . . . . .	4
11	EC12342354B5	SHACKLE, lifting . . . . .	2
12	12338225-1	BOLT, rear lifting shackle . . . . .	2
13	6006797B9	BRACKET, skid plate mounting, L.H. . . . .	1
13	6006798B9	BRACKET, skid plate mounting, R.H. . . . .	1
14	N/S	BOLT, 3/8 - 16 x 1, Gr8, CAD. . . . .	4
15	N/S	WASHER, flat, 3/8, type B . . . . .	4
16	6006741B5	BRACKET, rear bumper, L.H. . . . .	1
16	6006749B5	BRACKET, rear bumper, R.H. . . . .	1
17	N/S	BOLT, 1/2 - 13 x 4 1/4, Gr8, CAD . . . . .	8

# 2001 HUMMER PARTS CATALOG

## 9-32 AXLES/SUSPENSION/FRAME

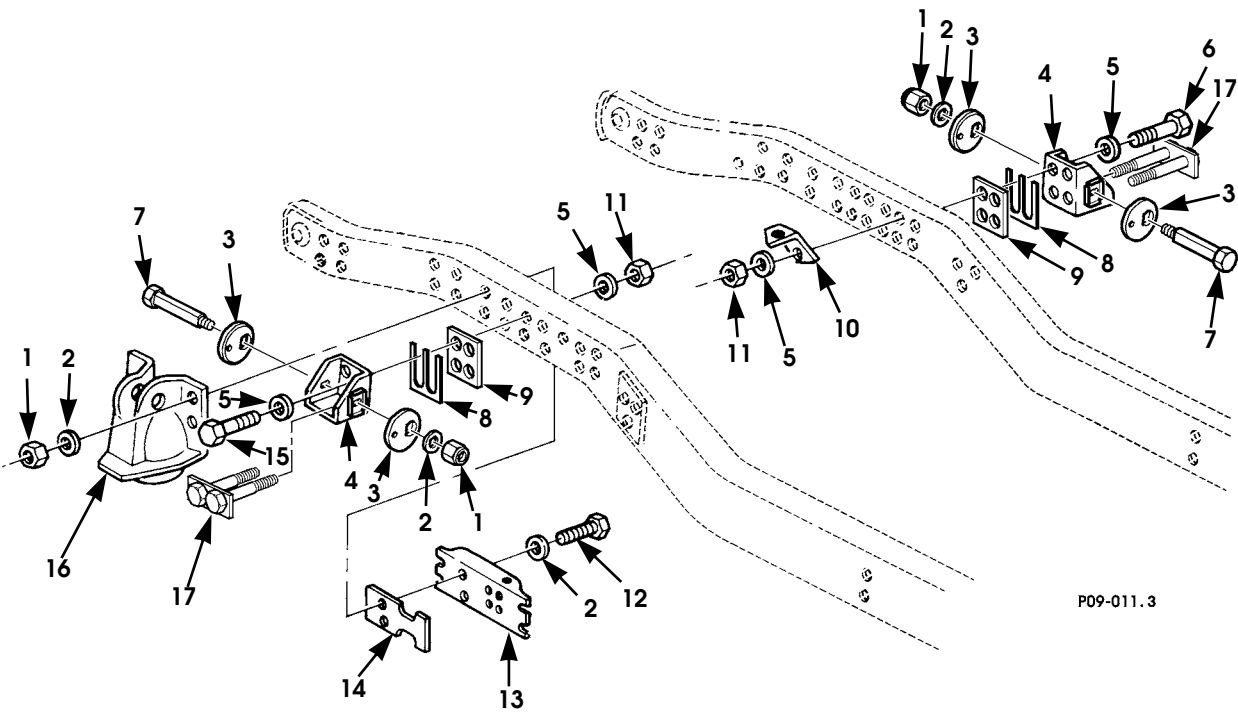

Figure 9-14. Upper Control Arm Brackets, Spring Seats, Related Parts, and Mounting Hardware.

# 2001 HUMMER PARTS CATALOG

## AXLES/SUSPENSION/FRAME 9-33

ITEM	PART NUMBER	DESCRIPTION	QTY
		<b>Figure 9-14. Upper Control Arm Brackets, Spring Seats, Related Parts, and Mounting Hardware.</b>	
1	N/S	LOCKNUT, 3/4 - 10, Gr8, CAD . . . . .	12
2	N/S	WASHER, flat, hardened, 3/4, type B . . . . .	20
3	6009537	CAM, suspension alignment. . . . .	8
4	6009539B9	BRACKET, upper control arm, rear . . . . .	4
5	N/S	WASHER, flat, hardened, 1/2, type B . . . . .	32
6	N/S	BOLT, 1/2 - 13 x 4 1/4, Gr8, CAD, SEE NOTE 1 . . . . .	12
6	N/S	BOLT, 1/2 - 13 x 4, Gr8, CAD, SEE NOTE 2 . . . . .	12
7	6009807	BOLT, flat-sided, 3/4 - 10 x 5 1/4, control arm mounting . . . . .	4
8	12338226-1	SHIM, upper control arm mounting bracket, 0.060" . . . . .	A/R
8	12338226-2	SHIM, upper control arm mounting bracket, 0.120" . . . . .	A/R
9	6009543	SPACER, upper control arm mounting bracket, 0.125" . . . . .	A/R
9	6009573	SPACER, upper control arm mounting bracket, 0.250" . . . . .	A/R
10	12338172	BRACKET, vent tube. . . . .	1
11	N/S	LOCKNUT, 1/2 - 13, Gr8, CAD . . . . .	16
12	N/S	BOLT, 3/4 - 10 x 4 3/4, Gr8, CAD . . . . .	8
13	12338152	REINFORCEMENT, frame . . . . .	2
14	EC12338174B1	PLATE, frame reinforcement . . . . .	2
15	N/S	BOLT, 1/2 - 13 x 4 1/2, Gr8, CAD, SEE NOTE 1 . . . . .	8
15	N/S	BOLT, 1/2 - 13 x 4 1/4, Gr8, CAD, SEE NOTE 2 . . . . .	8
16	12338738	SEAT, rear spring . . . . .	2
17	N/S	BRACKET ASSEMBLY, mounting, rear, SEE NOTE 3. . . . .	2
		NOTE 1: USE WITH SHIM PACK/SPACER COMBINATION OF 0.250 INCH OR THICKER	
		NOTE 2: USE WITH SHIM PACK/SPACER COMBINATION OF UP TO 0.240-INCH THICK	
		NOTE 3: USE TWO ITEM #15 BOLTS (USE THE SIZE THAT IS CONSISTENT WITH THE SHIM PACK/SPACER COMBINATION) AND TWO ITEM #5 WASHERS TO REPLACE THIS ASSEMBLY.	

# 2001 HUMMER PARTS CATALOG

## 9-34 AXLES/SUSPENSION/FRAME

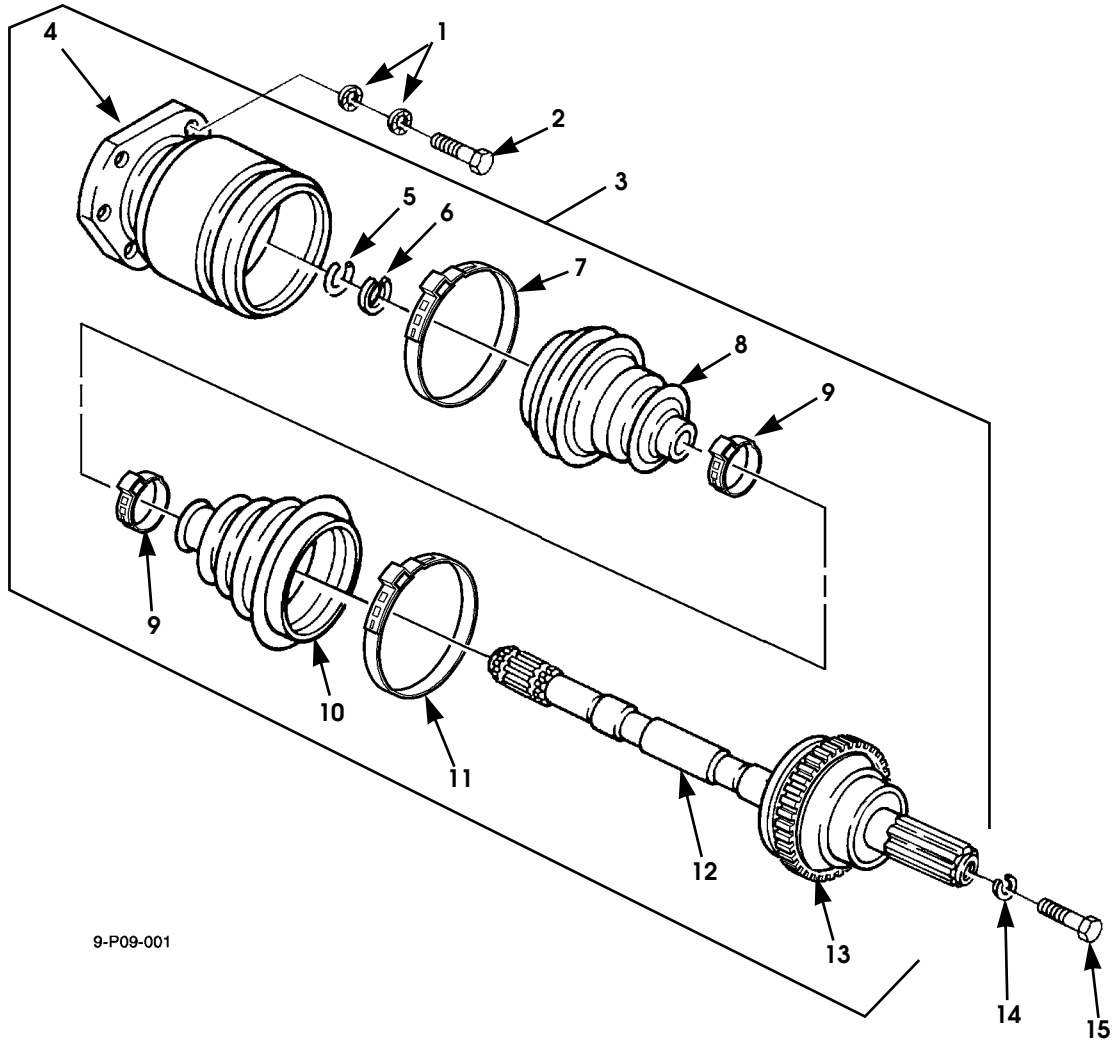

9-P09-001

Figure 9-15. Halfshaft Assembly, Left and Right Side.

# 2001 HUMMER PARTS CATALOG

## AXLES/SUSPENSION/FRAME 9-35

ITEM	PART NUMBER	DESCRIPTION	QTY
		<b>Figure 9-15. Halfshaft Assembly, Left and Right Side.</b>	
1	6008029	LOCKWASHER, M10, camlock, SEE Note 1 . . . . .	12
2	6008021	BOLT, M10 -1.5 x 35, class 10.9, Phos, SEE NOTE 1 . . . . .	6
3	6011466	HALFSHAFT ASSEMBLY, rear, L.H. and R.H. . . . .	2
3	6011469	HALFSHAFT ASSEMBLY, rear, L.H. and R.H., 12,100-lb GVW. . . . .	2
3	6011464	HALFSHAFT ASSEMBLY, front, R.H., . . . . .	1
3	6011467	HALFSHAFT ASSEMBLY, front, R.H., 12,100-lb GVW. . . . .	1
3	6011465	HALFSHAFT ASSEMBLY, front, L.H., . . . . .	1
3	6011468	HALFSHAFT ASSEMBLY, front, L.H., 12,100-lb GVW . . . . .	1
4	S.I.A.	•HOUSING, halfshaft, at axle . . . . .	1
5	S.I.A.	•RETAINING RING, shaft . . . . .	2
6	S.I.A.	•SPACER RING, halfshaft. . . . .	2
7	5744413	•CLAMP, plunge boot, SEE NOTES 2 AND 3. . . . .	1
7	5744623	•CLAMP, plunge boot, SEE NOTE 4. . . . .	1
8	S.I.A.	•BOOT, joint assembly, inner, SEE NOTE 3. . . . .	1
8	S.I.A.	•BOOT, joint assembly, inner, 12,100-lb GVW, SEE NOTE 4	1
9	5744414	•CLAMP, boot, inner, plunge and fixed joint assemblies, SEE NOTES 2 AND 3. . . . .	2
9	5744621	•CLAMP, boot, inner, plunge and fixed joint assemblies, 12,100-lb GVW, SEE NOTE 4. . . . .	2
10	S.I.A.	•BOOT, fixed joint assembly, SEE NOTE 2 . . . . .	1
10	S.I.A.	•BOOT, fixed joint assembly, 12,100-lb GVW, SEE NOTE 4	1
11	5744415	•CLAMP, boot, race, joint assembly, SEE NOTE 2 . . . . .	1
11	5744622	•CLAMP, boot, race, joint assembly, 12,100-lb GVW, SEE NOTE 4. . . . .	1
12	S.I.A.	•SHAFT, halfshaft, front, L.H.. . . . .	1
12	S.I.A.	•SHAFT, halfshaft, front, R.H. . . . .	1
12	S.I.A.	•SHAFT, halfshaft, rear, L.H. and R.H. . . . .	1
13	6009901	•TONE RING . . . . .	1
14	N/S	LOCKWASHER, med, 3/8, Phos . . . . .	1
15	N/S	SCREW, 3/8 -16 x 1 1/4, cap, Gr8, CAD . . . . .	1
		NOTE 1: QUANTITIES SHOWN ARE PER HALFSHAFT	
		NOTE 2: PART OF FIXED JOINT BOOT PARTS KIT P/N 5742776	
		NOTE 3: PART OF PLUNGE JOINT BOOT PARTS KIT P/N 5742775	
		NOTE 4: PART OF BOOT PARTS KIT P/N 5714538. BOOT KIT CONTAINS 2 IDENTICAL BOOTS AND 4 CLAMPS	



# 2001 HUMMER PARTS CATALOG

## 9-36 AXLES/SUSPENSION/FRAME

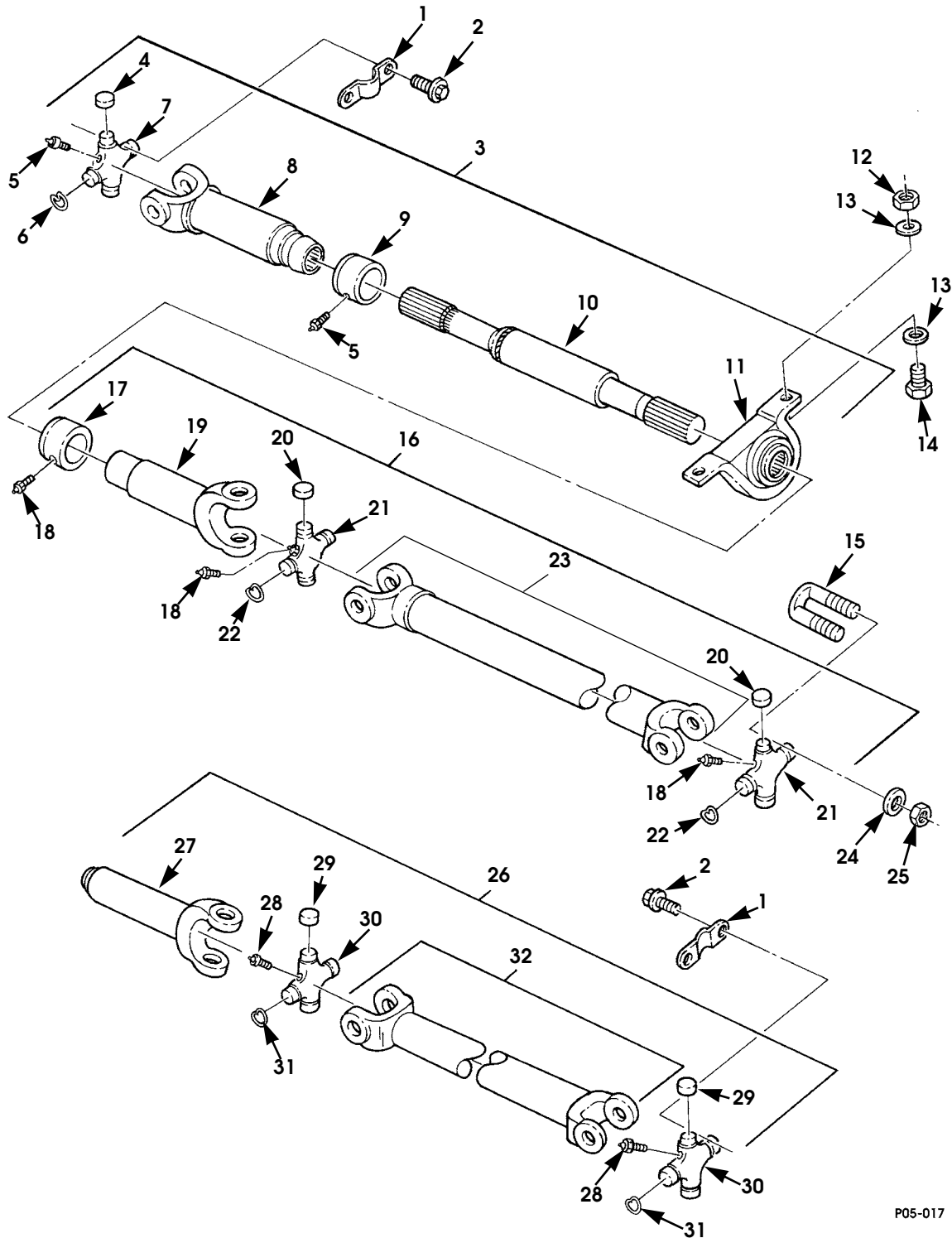

P05-017

Figure 9-16. Propeller Shafts.

# 2001 HUMMER PARTS CATALOG

## AXLES/SUSPENSION/FRAME 9-37

ITEM	PART NUMBER	DESCRIPTION	QTY
		<b>Figure 9-16. Propeller Shafts.</b>	
1	12339301	STRAP, cross assembly, bearing . . . . .	4
1	5937636	STRAP, cross assembly, bearing, 12,100-lb GVW . . . . .	2
2	12339049	SCREW, cross assembly, 1/4 - 28 x 5/8 . . . . .	8
2	5937637	SCREW, cross assembly, 5/16 - 24 x 3/4, 12,100-lb GVW	4
3	6000262	PROPSHAFT, collapsing, front . . . . .	1
4	S.I.K.	•BEARING RACE, SEE NOTE 1 . . . . .	4
5	MS15001-1	•FITTING, lubrication . . . . .	2
6	S.I.K.	•RING, SEE NOTE 1 . . . . .	2
7	S.I.K.	•CROSS ASSEMBLY, SEE NOTE 1 . . . . .	1
8	S.I.A.	•YOKE, universal . . . . .	1
9	5740723	•DUST CAP . . . . .	1
10	S.I.A.	•PROPELLER SHAFT, front . . . . .	1
11	5741082	•BEARING, center . . . . .	1
12	N/S	NUT, 7/16 - 14, Gr8, CAD . . . . .	2
13	N/S	WASHER, flat, 7/16, type B, hard . . . . .	4
14	N/S	SCREW, 7/16 - 14 x 1, Gr8, CAD . . . . .	2
15	EC12339050	U-BOLT, 5/16 - 24. . . . .	2
16	12447114	DRIVE SHAFT, front . . . . .	1
17	5740723	•DUST CAP . . . . .	1
18	MS15001-1	•FITTING, lubrication . . . . .	3
19	5937482	•YOKE, universal . . . . .	1
20	S.I.K.	•BEARING RACE, SEE NOTE 1 . . . . .	8
21	S.I.K.	•CROSS ASSEMBLY, SEE NOTE 1 . . . . .	2
22	S.I.K.	•RING, SEE NOTE 1 . . . . .	6
23	S.I.A.	•PROPELLER SHAFT, front middle . . . . .	1
24	N/S	LOCKWASHER, med, 5/16, CAD . . . . .	4
25	N/S	NUT, 5/16 - 24, Gr8 . . . . .	4
26	12447113	PROPSHAFT, rear . . . . .	1
26	RCSK17057	PROPSHAFT, rear, 12,100-lb GVW . . . . .	1
27	5743957	•SLIP YOKE, universal joint . . . . .	1
28	MS15001-1	•FITTING, lubrication . . . . .	2
29	S.I.K.	•BEARING RACE, SEE NOTE 2 . . . . .	8
30	S.I.K.	•CROSS ASSEMBLY, SEE NOTE 2 . . . . .	2
31	S.I.K.	•RING, SEE NOTE 1 . . . . .	6
32	S.I.A.	•PROPELLER SHAFT, rear . . . . .	1
		NOTE 1: USE JOURNAL AND BEARING KIT P/N 5595706.	
		NOTE 2: USE JOURNAL AND BEARING KIT P/N 5714519	

# 2001 HUMMER PARTS CATALOG

## 9-38 AXLES/SUSPENSION/FRAME

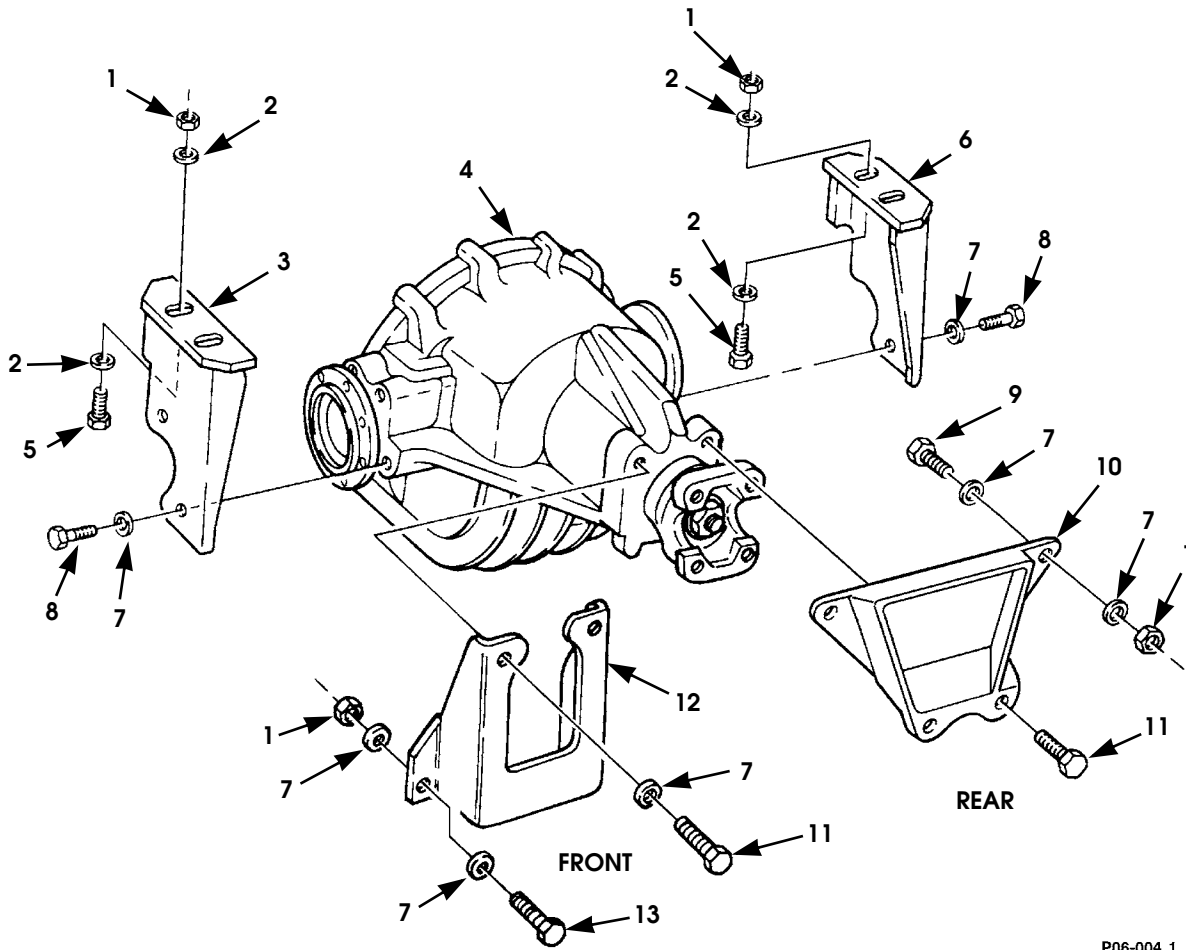

P06-004.1

Figure 9-17. Axle Differential, Mounting Brackets, and Hardware.

# 2001 HUMMER PARTS CATALOG

## AXLES/SUSPENSION/FRAME 9-39

ITEM	PART NUMBER	DESCRIPTION	QTY
		<b>Figure 9-17.</b> <b>Axle Differential, Mounting Brackets, and Hardware.</b>	
1	N/S	LOCKNUT, 1/2 - 13, Gr8 . . . . .	2
2	N/S	WASHER, flat, hard, 1/2, type B . . . . .	4
3	12338150-1	BRACKET, front differential, L.H. . . . .	1
3	12338151-2	BRACKET, rear differential, R.H. . . . .	1
4	6008127	AXLE ASSEMBLY, front or rear, 2.56:1 ratio . . . . .	2
4	6009872	AXLE ASSEMBLY, front, 3.08:1 ratio, 12,100-lb GVW . . . .	1
4	6008128	AXLE ASSEMBLY, rear, 3.08:1 ratio, 12, 100-lb GVW . . . .	1
5	N/S	SCREW, 1/2 - 13 x 1 1/4, Gr8, CAD . . . . .	2
5	N/S	SCREW, 1/2 - 13 x 1 1/2, Gr8, CAD, 12,100-lb GVW . . . .	4
6	12338150-2	BRACKET, front differential, R.H. . . . .	1
6	12338151-1	BRACKET, rear differential, L.H. . . . .	1
7	N/S	WASHER, flat, hard, 5/8, type B . . . . .	8
8	N/S	SCREW, lock, 5/8 - 11 x 1 1/4, Gr8, Phos . . . . .	2
9	N/S	SCREW, 1/2 - 13 x 3 1/4, Gr8, CAD . . . . .	2
10	12341900	BRACKET, rear axle. . . . .	1
11	N/S	BOLT, 5/8 - 11 x 1 1/2. . . . .	2
12	12342801	BRACKET, front axle pinion . . . . .	1
13	N/S	SCREW, 1/2 - 13 x 1, Gr8, CAD. . . . .	2

# 2001 HUMMER PARTS CATALOG

## 9-40 AXLES/SUSPENSION/FRAME

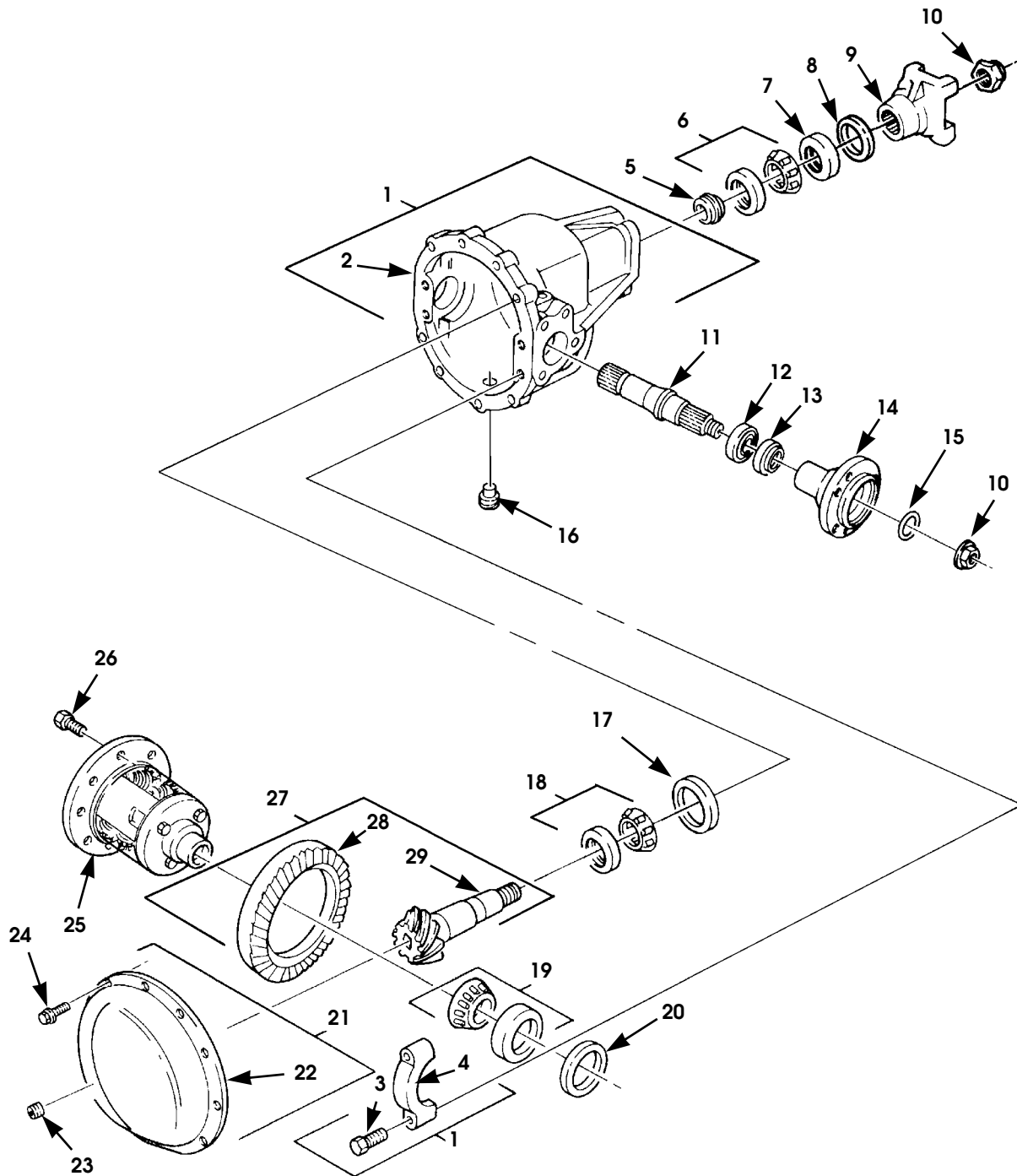

P06-009

Figure 9-18. Axle Differential.

# 2001 HUMMER PARTS CATALOG

## AXLES/SUSPENSION/FRAME 9-41

ITEM	PART NUMBER	DESCRIPTION	QTY
		<b>Figure 9-18. Axle Differential.</b>	
1	5579424	HOUSING ASSEMBLY, mechanical, axle differential . . .	1
2	S.I.A.	•HOUSING, axle differential . . . . .	1
3	5595662	•BOLT, 1/2 -13 x 2.35", bearing cap . . . . .	4
4	S.I.A.	•CAP, bearing . . . . .	2
5	5579450	SPACER, axle pinion . . . . .	1
6	5583610	BEARING, axle pinion . . . . .	1
7	5579448	SEAL, axle pinion . . . . .	1
8	5598183	SLINGER, axle . . . . .	2
9	5597328	YOKE, differential pinion . . . . .	2
9	5937525	YOKE, differential pinion, rear, 12,100-lb GVW . . . . .	1
10	5579442	LOCKNUT, axle shaft . . . . .	3
11	6010942	SHAFT, axle output . . . . .	2
12	5579988	BEARING, output shaft . . . . .	2
13	6009472	SEAL, output shaft . . . . .	2
14	5593817	FLANGE, output shaft . . . . .	2
15	5939517	SEAL, star washer, output shaft . . . . .	2
16	5593148	MAGNETIC PLUG, differential housing drain . . . . .	1
17	5579445-79	SPACER, axle pinion bearing, 0.0835-0.0845-inch, SEE NOTE 1 . . . . .	1
17	5579445-78	SPACER, axle pinion bearing, 0.0846-0.0856-inch, SEE NOTE 1 . . . . .	1
17	5579445-77	SPACER, axle pinion bearing, 0.0857-0.0867-inch, SEE NOTE 1 . . . . .	1
17	5579445-76	SPACER, axle pinion bearing, 0.0868-0.0878-inch, SEE NOTE 1 . . . . .	1
17	5579445-75	SPACER, axle pinion bearing, 0.0879-0.0889-inch, SEE NOTE 1 . . . . .	1
17	5579445-74	SPACER, axle pinion bearing, 0.0890-0.0900-inch, SEE NOTE 1 . . . . .	1
17	5579445-73	SPACER, axle pinion bearing, 0.0901-0.0911-inch, SEE NOTE 1 . . . . .	1
17	5579445-72	SPACER, axle pinion bearing, 0.0912-0.0922-inch, SEE NOTE 1 . . . . .	1
17	5579445-71	SPACER, axle pinion bearing, 0.0923-0.0933-inch, SEE NOTE 1 . . . . .	1
17	5579445-70	SPACER, axle pinion bearing, 0.0934-0.0944-inch, SEE NOTE 1 . . . . .	1
17	5579445-69	SPACER, axle pinion bearing, 0.0945-0.0955-inch, SEE NOTE 1 . . . . .	1
17	5579445-68	SPACER, axle pinion bearing, 0.0956-0.0966-inch, SEE NOTE 1 . . . . .	1

# 2001 HUMMER PARTS CATALOG

## 9-42 AXLES/SUSPENSION/FRAME

ITEM	PART NUMBER	DESCRIPTION	QTY
		<b>Figure 9-18. Axle Differential. (Cont'd)</b>	
17	5579445-67	SPACER, axle pinion bearing, 0.0967-0.0977-inch, SEE NOTE 1 . . . . .	1
17	5579445-66	SPACER, axle pinion bearing, 0.0978-0.0988-inch, SEE NOTE 1 . . . . .	1
17	5579445-65	SPACER, axle pinion bearing, 0.0989-0.0999-inch, SEE NOTE 1 . . . . .	1
17	5579445-64	SPACER, axle pinion bearing, 0.1000-0.1010-inch, SEE NOTE 1 . . . . .	1
17	5579445-63	SPACER, axle pinion bearing, 0.1011-0.1021-inch, SEE NOTE 1 . . . . .	1
17	5579445-62	SPACER, axle pinion bearing, 0.1022-0.1032-inch, SEE NOTE 1 . . . . .	1
17	5579445-61	SPACER, axle pinion bearing, 0.1033-0.1043-inch, SEE NOTE 1 . . . . .	1
17	5579445-60	SPACER, axle pinion bearing, 0.1044-0.1054-inch, SEE NOTE 1 . . . . .	1
17	5579445-59	SPACER, axle pinion bearing, 0.1055-0.1065-inch, SEE NOTE 1 . . . . .	1
17	5579445-58	SPACER, axle pinion bearing, 0.1066-0.1076-inch, SEE NOTE 1 . . . . .	1
17	5579445-57	SPACER, axle pinion bearing, 0.1077-0.1087-inch, SEE NOTE 1 . . . . .	1
17	5579445-56	SPACER, axle pinion bearing, 0.1088-0.1098-inch, SEE NOTE 1 . . . . .	1
17	5579445-55	SPACER, axle pinion bearing, 0.1099-0.1109-inch, SEE NOTE 1 . . . . .	1
17	5579445-54	SPACER, axle pinion bearing, 0.1110-0.1120-inch, SEE NOTE 1 . . . . .	1
18	5583609	BEARING, axle pinion . . . . .	1
19	5583611	ROLLER BEARING, output shaft . . . . .	2
20	5579453-44	SPACER, differential bearing, 0.0745-0.0755-inch, SEE NOTE 2 . . . . .	1
20	5579453-45	SPACER, differential bearing, 0.0756-0.0766-inch, SEE NOTE 2 . . . . .	1
20	5579453-46	SPACER, differential bearing, 0.0767-0.0777-inch, SEE NOTE 2 . . . . .	1
20	5579453-47	SPACER, differential bearing, 0.0778-0.0788-inch, SEE NOTE 2 . . . . .	1
20	5579453-48	SPACER, differential bearing, 0.0789-0.0799-inch, SEE NOTE 2 . . . . .	1

# 2001 HUMMER PARTS CATALOG

## AXLES/SUSPENSION/FRAME 9-43

ITEM	PART NUMBER	DESCRIPTION	QTY
		<b>Figure 9-18. Axle Differential. (Cont'd)</b>	
20	5579453-49	SPACER, differential bearing, 0.0800-0.0810-inch, SEE NOTE 2 . . . . .	1
20	5579453-50	SPACER, differential bearing, 0.0811-0.0821-inch, SEE NOTE 2 . . . . .	1
20	5579453-51	SPACER, differential bearing, 0.0822-0.0832-inch, SEE NOTE 2 . . . . .	1
20	5579453-52	SPACER, differential bearing, 0.0833-0.0843-inch, SEE NOTE 2 . . . . .	1
20	5579453-53	SPACER, differential bearing, 0.0844-0.0854-inch, SEE NOTE 2 . . . . .	1
20	5579453-54	SPACER, differential bearing, 0.0855-0.0865-inch, SEE NOTE 2 . . . . .	1
20	5579453-55	SPACER, differential bearing, 0.0866-0.0876-inch, SEE NOTE 2 . . . . .	1
20	5579453-56	SPACER, differential bearing, 0.0877-0.0887-inch, SEE NOTE 2 . . . . .	1
20	5579453-57	SPACER, differential bearing, 0.0888-0.0898-inch, SEE NOTE 2 . . . . .	1
20	5579453-58	SPACER, differential bearing, 0.0899-0.0909-inch, SEE NOTE 2 . . . . .	1
20	5579453-59	SPACER, differential bearing, 0.0910-0.0920-inch, SEE NOTE 2 . . . . .	1
20	5579453-60	SPACER, differential bearing, 0.0921-0.0931-inch, SEE NOTE 2 . . . . .	1
20	5579453-61	SPACER, differential bearing, 0.0932-0.0942-inch, SEE NOTE 2 . . . . .	1
20	5579453-62	SPACER, differential bearing, 0.0943-0.0953-inch, SEE NOTE 2 . . . . .	1
20	5579453-63	SPACER, differential bearing, 0.0954-0.0964-inch, SEE NOTE 2 . . . . .	1
20	5579453-64	SPACER, differential bearing, 0.0965-0.0975-inch, SEE NOTE 2 . . . . .	1
20	5579453-65	SPACER, differential bearing, 0.0976-0.0986-inch, SEE NOTE 2 . . . . .	1
20	5579453-66	SPACER, differential bearing, 0.0987-0.0997-inch, SEE NOTE 2 . . . . .	1
20	5579453-67	SPACER, differential bearing, 0.0998-0.1008-inch, SEE NOTE 2 . . . . .	1
20	5579453-68	SPACER, differential bearing, 0.1009-0.1020-inch, SEE NOTE 2 . . . . .	1
20	5579453-69	SPACER, differential bearing, 0.1020-0.1030-inch, SEE NOTE 2 . . . . .	1
20	5579453-70	SPACER, differential bearing, 0.1031-0.1041-inch, SEE NOTE 2 . . . . .	1



# 2001 HUMMER PARTS CATALOG

## 9-44 AXLES/SUSPENSION/FRAME







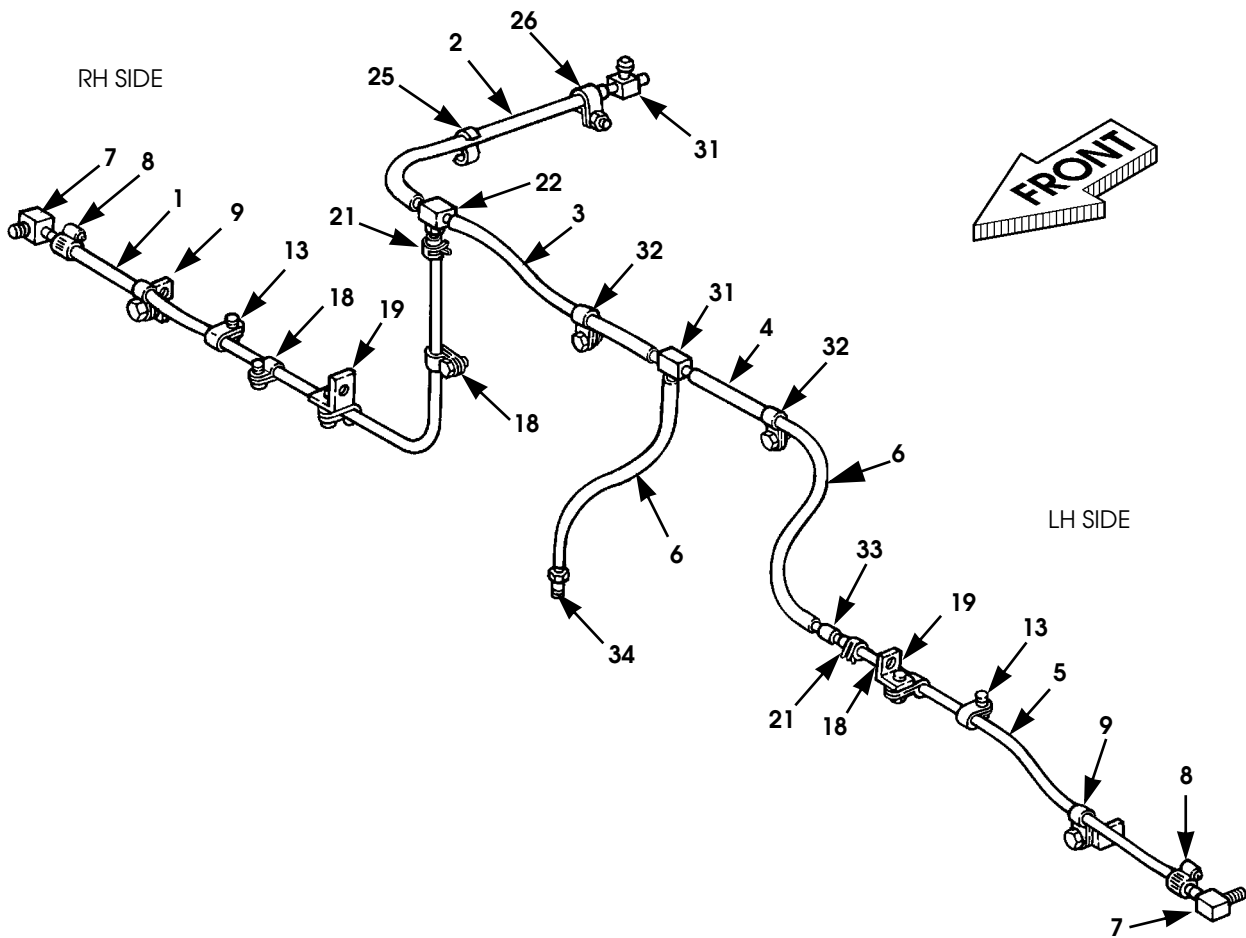

ITEM	PART NUMBER	DESCRIPTION	QTY
		<b>Figure 9-18.</b> <b>Axle Differential. (Cont'd)</b>	
20	5579453-71	SPACER, differential bearing, 0.1042-0.1052-inch, SEE NOTE 2 . . . . .	1
20	5579453-72	SPACER, differential bearing, 0.1053-0.1063-inch, SEE NOTE 2 . . . . .	1
20	5579453-73	SPACER, differential bearing, 0.1064-0.1074-inch, SEE NOTE 2 . . . . .	1
20	5579453-74	SPACER, differential bearing, 0.1075-0.1085-inch, SEE NOTE 2 . . . . .	1
20	5579453-75	SPACER, differential bearing, 0.1086-0.1096-inch, SEE NOTE 2 . . . . .	1
20	5579453-76	SPACER, differential bearing, 0.1097-0.1107-inch, SEE NOTE 2 . . . . .	1
20	5579453-77	SPACER, differential bearing, 0.1108-0.1118-inch, SEE NOTE 2 . . . . .	1
20	5579453-78	SPACER, differential bearing, 0.1119-0.1129-inch, SEE NOTE 2 . . . . .	1
20	5579453-79	SPACER, differential bearing, 0.1130-0.1140-inch, SEE NOTE 2 . . . . .	1
20	5579453-80	SPACER, differential bearing, 0.1141-0.1151-inch, SEE NOTE 2 . . . . .	1
20	5579453-81	SPACER, differential bearing, 0.1152-0.1162-inch, SEE NOTE 2 . . . . .	1
20	5579453-82	SPACER, differential bearing, 0.1163-0.1173-inch, SEE NOTE 2 . . . . .	1
20	5579453-83	SPACER, differential bearing, 0.1174-0.1184-inch, SEE NOTE 2 . . . . .	1
21	5582303	COVER ASSEMBLY, differential axle . . . . .	1
22	S.I.A.	•COVER, differential axle . . . . .	1
23	5597050	•PLUG, 1/2 - 14, differential cover . . . . .	1
24	5579438	•SCREW, differential cove . . . . .	12
25	6009873	DIFFERENTIAL, axle, standard, front and rear. . . . .	1
26	5579439	SCREW, differential . . . . .	8
27	5579501	GEAR SET, ring and pinion, 2.56:1 ratio. . . . .	1
27	RCSK17306	GEAR SET, ring and pinion, 3.08:1 ratio. . . . .	1
28	S.I.A.	•RING, gear and pinion . . . . .	1
29	S.I.A.	•PINION . . . . .	1
		NOTE 1: PART OF AXLE PINION BEARING SHIM KIT P/N 5579445. KIT CONTAINS SPACERS P/N 5579445 54 THROUGH P/N 5579445-79	
		NOTE 2: PART OF DIFFERENTIAL BEARING SHIM KIT P/N 5579453. KIT CONTAINS SPACERS P/N 5579453 -44 THROUGH P/N 5579453-83	

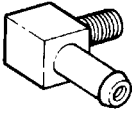

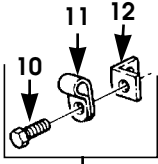
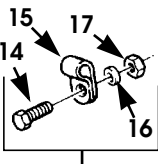
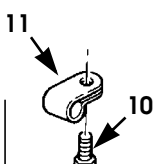
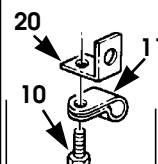
# 2001 HUMMER PARTS CATALOG

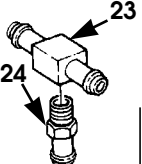
## 9-46 AXLES/SUSPENSION/FRAME

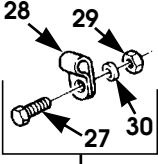
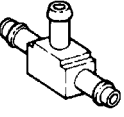
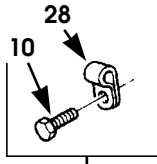
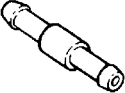

 VIEW 7	 VIEW 8	 VIEW 9	 VIEW 13	 VIEW 18	 VIEW 19	 VIEW 21
 VIEW 22	 VIEW 25	 VIEW 26	 VIEW 31	 VIEW 32	 VIEW 33	 VIEW 34

P06-005

Figure 9-19. Vent Lines, Front Axle and Geared Hub.

# 2001 HUMMER PARTS CATALOG



## AXLES/SUSPENSION/FRAME 9-47

ITEM	PART NUMBER	DESCRIPTION	QTY
		<b>Figure 9-19.</b> <b>Vent Lines, Front Axle and Geared Hub.</b>	
1	NPN	HOSE, 32-inch, geared hub vent line, R.H., SEE NOTE 1	1
2	NPN	TUBE, 20-inch, differential and geared hub vent line, SEE NOTE 2 . . . . .	1
3	NPN	TUBE, 14-inch, differential and geared hub vent line, SEE NOTE 2 . . . . .	1
4	NPN	TUBE, 12-inch, differential and geared hub vent line, SEE NOTE 2 . . . . .	1
5	NPN	HOSE, 25-inch, geared hub vent line, L.H., SEE NOTE 1	1
6	NPN	TUBE, 8-inch, differential vent line, SEE NOTE 2 . . . . .	2
7	6006440	ELBOW, male, geared hub vent line, 90 degree . . . . .	2
8	12339884	CLAMP, screw type . . . . .	2
9	NPN	CLAMP ASSEMBLY . . . . .	2
10	N/S	•SCREW, tapping, 3/8 - 16 x 5/8, ZN. . . . .	1
11	N/S	•CLAMP, cushioned, 5/8" . . . . .	1
12	5598208	•BRACKET, vent line . . . . .	1
13	NPN	CLAMP ASSEMBLY . . . . .	2
14	N/S	•SCREW, 1/4 - 20 x 3/4, Gr5, CAD . . . . .	1
15	12340571-2	•CLAMP, vent line . . . . .	1
16	N/S	•WASHER, flat, 1/4, CAD . . . . .	1
17	N/S	•LOCKNUT, 1/4 - 20, Gr8 . . . . .	1
18	NPN	CLAMP ASSEMBLY . . . . .	2
10	N/S	•SCREW, tapping, 3/8 - 16 x 5/8, ZN. . . . .	1
11	N/S	•CLAMP, cushioned, 5/8" . . . . .	1
19	NPN	BRACKET ASSEMBLY . . . . .	2
10	N/S	•SCREW, tapping, 3/8 - 16 x 5/8, ZN. . . . .	1
11	N/S	•CLAMP, cushioned, 5/8" . . . . .	1
20	12338170	•BRACKET, vent line . . . . .	1
21	WWC440-1/2	CLAMP, vent line, 1/2-inch, pinch type . . . . .	2
22	NPN	ADAPER ASSEMBLY . . . . .	1
23	12339969	•TEE, vent line. . . . .	1
24	12340331	•ADAPTER, vent line . . . . .	1
25	12339890	S-CLIP, vent line. . . . .	1
26	NPN	CLAMP ASSEMBLY . . . . .	1
27	N/S	•BOLT, 5/16 - 18 x 1, Gr5, CAD. . . . .	1
28	N/S	•CLAMP, cushioned, 1/4" . . . . .	1
29	N/S	•WASHER, flat, 5/16, CAD . . . . .	1
30	N/S	•LOCKNUT, 5/16 - 18, Gr8 . . . . .	1
31	12339973-1	TEE, vent line. . . . .	2
32	NPN	CLAMP ASSEMBLY . . . . .	2
10	N/S	•SCREW, tapping, 3/8 - 16 x 5/8, ZN. . . . .	1
28	N/S	•CLAMP, cushioned, 1/4" . . . . .	1
33	12339972	UNION, vent line. . . . .	1
34	12339978	CONNECTOR, differential vent line . . . . .	1
	6005755	TAPE, heat, vent line, 3/4" (not illustrated). . . . .	A/R
		NOTE 1: MAKE FROM BULK HOSE P/N 5741210	
		NOTE 2: MAKE FROM BULK NYLON TUBE P/N 5741079	

# 2001 HUMMER PARTS CATALOG

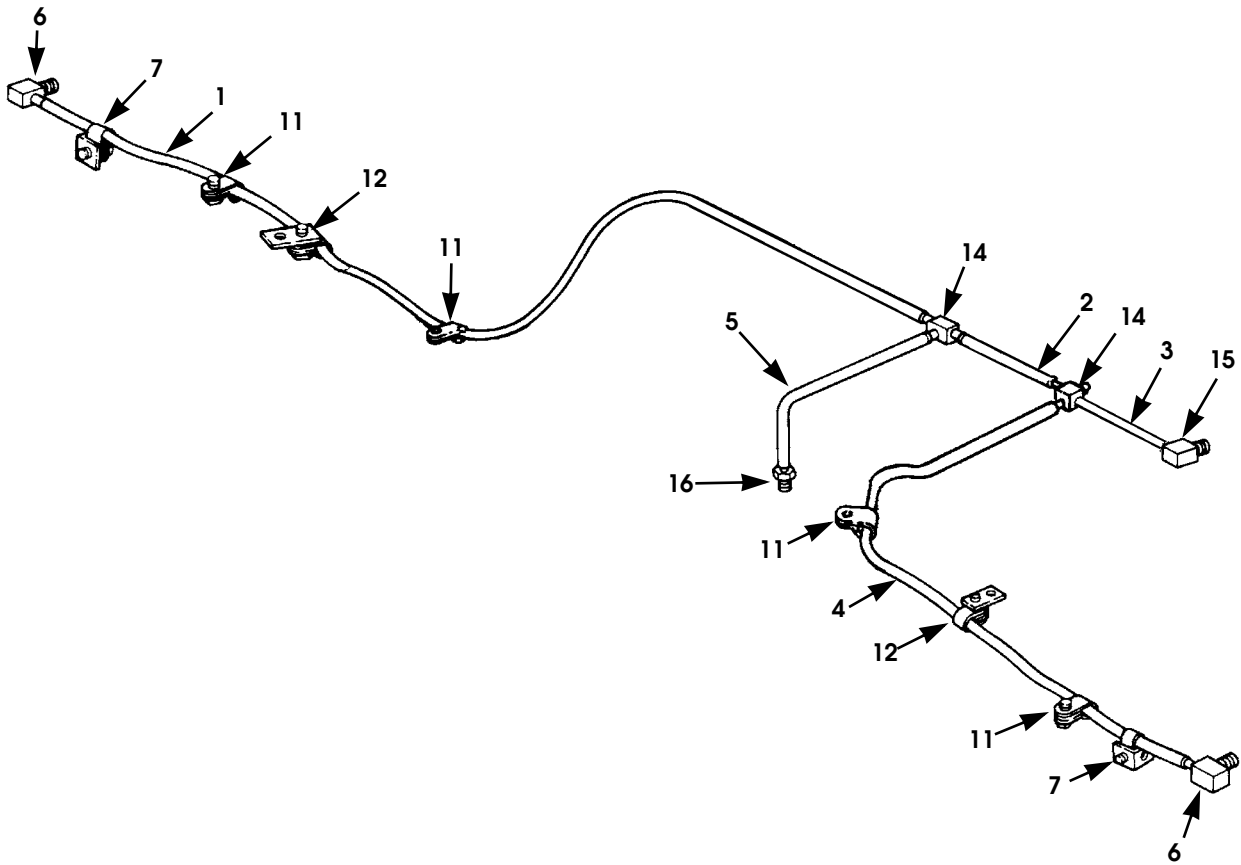
## 9-48 AXLES/SUSPENSION/FRAME

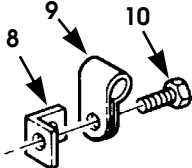
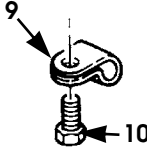
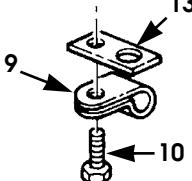
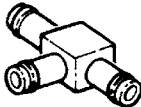
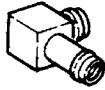

 <p>VIEW 6</p>	 <p>VIEW 7</p>	 <p>VIEW 11</p>	 <p>VIEW 12</p>
 <p>VIEW 14</p>	 <p>VIEW 15</p>	 <p>VIEW 16</p>	

P06-008.1

Figure 9-20. Vent Lines, Rear Axle and Geared Hub.

# 2001 HUMMER PARTS CATALOG

## AXLES/SUSPENSION/FRAME 9-49

ITEM	PART NUMBER	DESCRIPTION	QTY
		<b>Figure 9-20.</b> <b>Vent Lines, Rear Axle and Geared Hub.</b>	
1	NPN	TUBE, 42-inch, geared hub vent line, L.H., SEE NOTE 1 .	1
2	NPN	TUBE, 7-inch, differential and geared hub vent line, SEE NOTE 1 . . . . .	1
3	NPN	TUBE, 5-inch, SEE NOTE 1 . . . . .	1
4	NPN	TUBE, 35.50-inch, geared hub vent line, R.H., SEE NOTE 1 . . . . .	1
5	NPN	TUBE, 10-inch, differential vent line, SEE NOTE 1 . . . . .	1
6	2339964-1	ELBOW, male, geared hub vent lines, 90 degree. . . . .	2
7	NPN	BRACKET ASSEMBLY . . . . .	2
8	5598208	•BRACKET, vent lines . . . . .	1
9	N/S	•CLAMP, cushioned, 1/4" . . . . .	1
10	N/S	•SCREW, tapping, 3/8 - 16 x 5/8, ZN. . . . .	1
11	NPN	CLAMP ASSEMBLY . . . . .	4
9	N/S	•CLAMP, cushioned, 1/4" . . . . .	1
10	N/S	•SCREW, tapping, 3/8 - 16 x 5/8, ZN. . . . .	1
12	NPN	PLATE ASSEMBLY . . . . .	2
9	N/S	•CLAMP, cushioned, 1/4" . . . . .	1
10	N/S	•SCREW, tapping, 3/8 - 16 x 5/8, ZN. . . . .	1
13	12338172	•PLATE, geared hub vent lines. . . . .	2
14	12339973-1	TEE, vent lines . . . . .	2
15	12339979-1	ELBOW, 90 degree . . . . .	1
16	12339978	CONNECTOR, vent line . . . . .	1
	6005755	TAPE, heat, vent line, 3/4" (not illustrated). . . . .	A/R
		 NOTE 1: MAKE FROM BULK NYLON TUBE P/N 5741079	

# 2001 HUMMER PARTS CATALOG

## 9-50 AXLES/SUSPENSION/FRAME

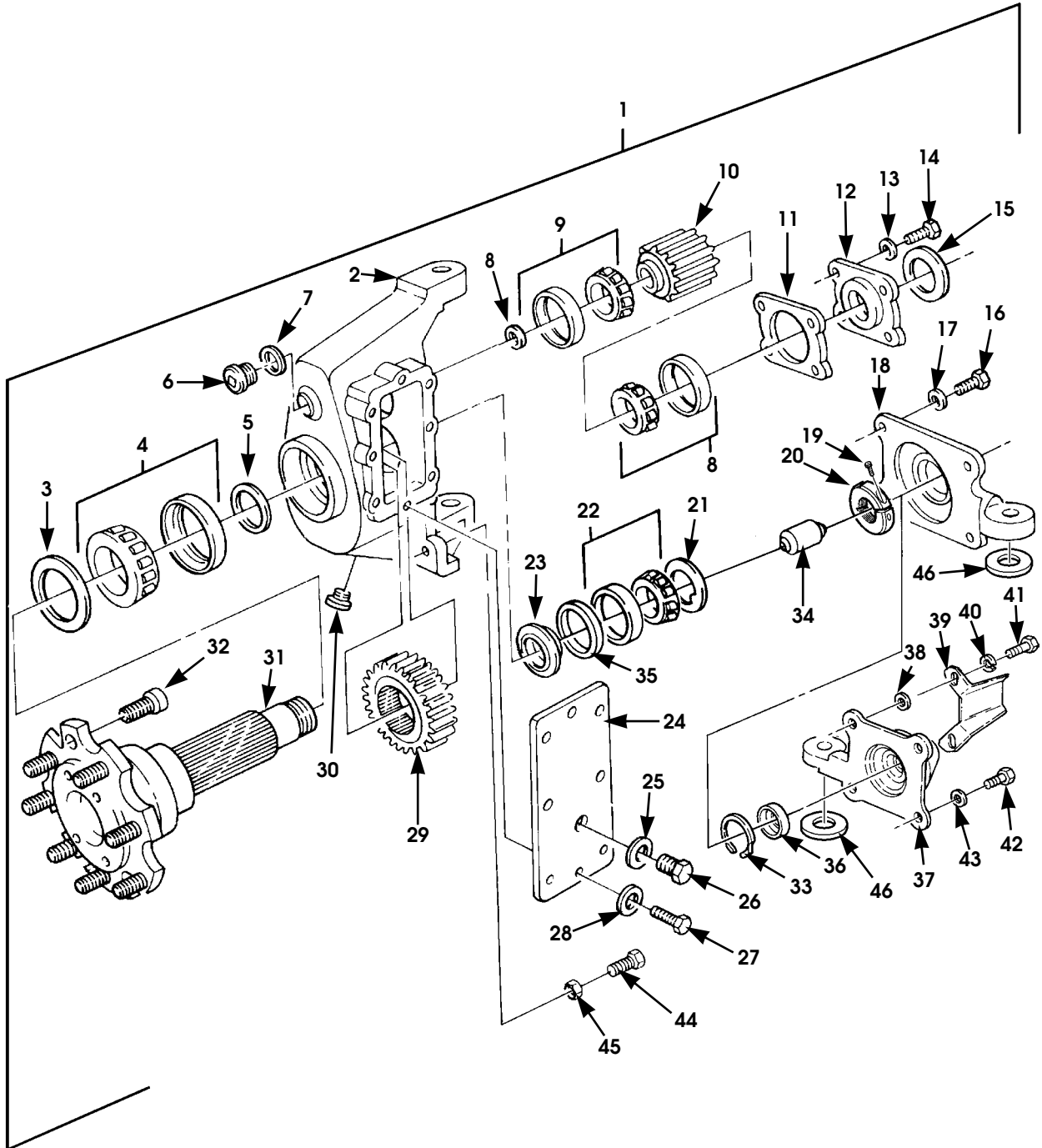

P06-006.3

Figure 9-21. Geared Hub (Knuckle) Assemblies.

# 2001 HUMMER PARTS CATALOG

## AXLES/SUSPENSION/FRAME 9-51

ITEM	PART NUMBER	DESCRIPTION	QTY
		<b>Figure 9-21. Geared Hub (Knuckle) Assemblies.</b>	
1	6011470	GEARED HUB, L.H. rear . . . . .	1
1	6011471	GEARED HUB, R.H. rear . . . . .	1
1	6011473	GEARED HUB, CTI, noise-reduced, R.H. front . . . . .	1
1	6011472	GEARED HUB, CTI, noise-reduced, L.H. front . . . . .	1
1	6011474	GEARED HUB, CTI, 12,100-lb GVW, R.H. front (For Fleet Use Only) . . . . .	1
1	6011475	GEARED HUB, CTI, 12,100-lb GVW, L.H. front (For Fleet Use Only) . . . . .	1
1	6011476	GEARED HUB, CTI, 12,100-lb GVW, R.H. rear (For Fleet Use Only) . . . . .	1
1	6011477	GEARED HUB, CTI, 12,100-lb GVW, L.H. rear (For Fleet Use Only) . . . . .	1
2	S.I.A.	•KNUCKLE HOUSING . . . . .	1
3	5745323	•KIT, output seal, geared hub . . . . .	1
4	MS19081-86	•BEARING, spindle, outer . . . . .	1
5	5573989	•SPACER, outer spindle . . . . .	1
6	5595214	•PLUG, upper access . . . . .	1
7	5573688	•WASHER, upper access plug . . . . .	1
8	5568223	•WASHER, halfshaft . . . . .	1
8	6009454	•WASHER, halfshaft, 12,100-lb GVW . . . . .	1
9	5568226	•BEARING, upper gear . . . . .	2
10	6007115	•GEAR, upper . . . . .	1
10	6009453	•GEAR, upper, 12,100-lb GVW . . . . .	1
11	5573692	•SHIM, gasket, 0.005-inch . . . . .	A/R
12	5574002	•RETAINER, upper gear . . . . .	1
13	N/S	•WASHER, flat, upper gear retainer, 3/8", ZN . . . . .	4
14	N/S	•BOLT, 3/8 - 16 x 1, Gr8, CAD. . . . .	4
15	5745324	•KIT, input seal, geared hub . . . . .	1
16	N/S	•BOLT, 1/2 - 13 x 1 1/4, w/o CTIS, Gr8, CAD . . . . .	4
17	N/S	•WASHER, flat, 1/2, w/o CTIS, ZN . . . . .	4
18	6005121	•COVER, steering arm, CTI, 12,100-lb GVW front L.H. and rear R.H. . . . .	1
18	6005120	•COVER, steering arm, CTI, 12,100-lb GVW front R.H. and rear L.H. . . . .	1
19	6001757	•LOCKSCREW, clampnut . . . . .	1
20	6001735	•CLAMPNUT, bearing to steering arm cover . . . . .	1
21	5573684	•WASHER, spindle . . . . .	1
22	5568227	•BEARING, inner. . . . .	1
23	6009350	•SPACER, inner bearing, w/ CTIS . . . . .	1
24	5574924	•ACCESS COVER, case side . . . . .	1



# 2001 HUMMER PARTS CATALOG

## 9-52 AXLES/SUSPENSION/FRAME

ITEM	PART NUMBER	DESCRIPTION	QTY
		<b>Figure 9-21. Geared Hub (Knuckle) Assemblies. (Cont'd)</b>	
25	5573687	•WASHER, fill plug, nylon . . . . .	1
26	5573690	•FILL PLUG, access cover . . . . .	1
27	5593348	•BOLT, side cover . . . . .	8
28	S.I.A.	•WASHER, flat, 5/16, CAD . . . . .	8
29	6007114	•GEAR, lower, output. . . . .	1
29	6009452	•GEAR, lower, output 12,100-lb GVW . . . . .	1
30	5593656	•MAGNETIC PLUG, lower pipe . . . . .	1
31	6009349	•SPINDLE . . . . .	1
31	5715160	•SPINDLE, 12,100-lb GVW . . . . .	1
32	5568211	•BOLT, spindle. . . . .	8
33	5594472	•RETAINER, hub . . . . .	1
34	5594531	•EXTENSION, spindle . . . . .	1
35	6001784	•SPACER, bearing, w/ CTIS or 12,100-lb GVW. . . . .	1
36	6005193	•SEAL, spindle. . . . .	1
37	6005120	•COVER, steering arm, rear L.H., front R.H. . . . .	1
37	6005121	•COVER, steering arm, rear R.H., front L.H. . . . .	1
38	5599210	•WASHER, flat, hardened, shield. . . . .	2
39	5598234	•SHIELD, CTIS tube, rear. . . . .	4
40	S.I.A.	•LOCKWASHER, med, 1/2, CAD . . . . .	2
41	S.I.A.	•BOLT, 1/2-13 x 1 3/8, Gr 5 . . . . .	2
42	S.I.A.	•SCREW, 1/2 - 13 x 1 1/4, Gr8. . . . .	4
43	S.I.A.	•WASHER, hard, 1/2, type B. . . . .	4
44	N/S	BOLT, 1/2 - 13 x 1 1/2, Gr8, CAD . . . . .	2
45	N/S	NUT, 1/2 - 13, Gr5, ZN . . . . .	2
46	N/S	WASHER, flat, hardened, 5/8" . . . . .	4

# 2001 HUMMER PARTS CATALOG

**BODY 10-1**

## Section 10

### BODY

TITLE	PAGE NUMBER
B- and C-Bars, Four-Passenger Hardtop and Station Wagon, Models 83 and 84 . . . . .	10-72
B-Bar, Two-Passenger Enlarged Cab, Model 89 . . . . .	10-70
Body Assembly . . . . .	10-4
Body Assembly Components, L.H. . . . .	10-6
Body Assembly Components, R.H. . . . .	10-8
Body Mounting Components . . . . .	10-2
Door Assembly, Front. . . . .	10-52
Door Assembly, Rear, Models 83, 84, and 90 . . . . .	10-56
Door Striker Assemblies, Front and Rear . . . . .	10-14
Engine Cover, Console Cover, and Related Parts . . . . .	10-48
Fixed Door, Footwell Cover, and Related Parts, Two-Passenger Enlarged Cab, Model 89 . . . . .	10-92
Floor Padding, Front and Rear. . . . .	10-112
Four-Door Soft Top Kit, Basic, Model 90 . . . . .	10-106
Headliner, Rear Trim and Carpet, Slant-Back, Model 91 . . . . .	10-132
Headliner, Rear Trim, and Carpet, Station Wagon, Model 84 . . . . .	10-130
Headliner, Roof Trim, Front and Rear Side Trim, Grab Handles, and Mounting Hardware (Delco Monsoon Stereo System) . . . . .	10-122
Headliner, Roof Trim, Front and Rear Side Trim, Grab Handles, and Mounting Hardware (Delco Standard Stereo System) . . . . .	10-116
Hood Assembly and Mounting Hardware . . . . .	10-16
Hood Assembly, Grille, and Related Parts . . . . .	10-20
Hood Release . . . . .	10-22
Inner Kick Panels and Miscellaneous Trim Panels . . . . .	10-136
Instrument Panel Assembly, Dash Trim, Crash Pad, and Mounting Hardware . . . . .	10-110
Interior Tunnel Padding, Carpet, and Hardboard . . . . .	10-114
Mirrors (Inside and Outside) and Mounting Hardware . . . . .	10-30
Monsoon Trim Pieces, Model 90 . . . . .	10-128
Outer Kick Panels Interior Trim . . . . .	10-62
Panel Assembly Door Trim . . . . .	10-94
Removable Load Barrier, Station Wagon, Model 84 . . . . .	10-108
Roof and Mounting Hardware, Four-Passenger Hardtop, Model 83 . . . . .	10-66
Roof and Mounting Hardware, Station Wagon, Model 84 . . . . .	10-68
Roof and Mounting Hardware, Two-Passenger Enlarged Cab, Model 89 . . . . .	10-64
Roof, Slant-Back Door, and Mounting Hardware, Slant-Back, Model 91 . . . . .	10-80
Seat Belts, Front and Rear . . . . .	10-44
Seats, Driver and Passenger. . . . .	10-40
Slant-Back Door Latch Assembly . . . . .	10-84
Slant-Back Door Mounting Components And Hinges . . . . .	10-86
Soft Top Support Structure, Model 90 . . . . .	10-99
Splash Shield (Left Hand) and Hood Prop Rod . . . . .	10-24
Splash Shield (Right Hand Upper) and Seals . . . . .	10-26
Splash Shield, Right Hand Lower . . . . .	10-28
Station Wagon Cargo Doors, Power Door Lock. . . . .	10-90
Station Wagon Rear Doors, Model 84. . . . .	10-75
Sun Visor . . . . .	10-32
Support Structure, Soft Top, Model 90 . . . . .	10-104
Tailgate Assembly and Related Parts . . . . .	10-60
Weathershield, Doors . . . . .	10-96
Window Assembly, Rear . . . . .	10-38
Windshield Assembly . . . . .	10-34
Windshield Washer Reservoir Mounting Support. . . . .	10-12

# 2001 HUMMER PARTS CATALOG

## 10-2 BODY

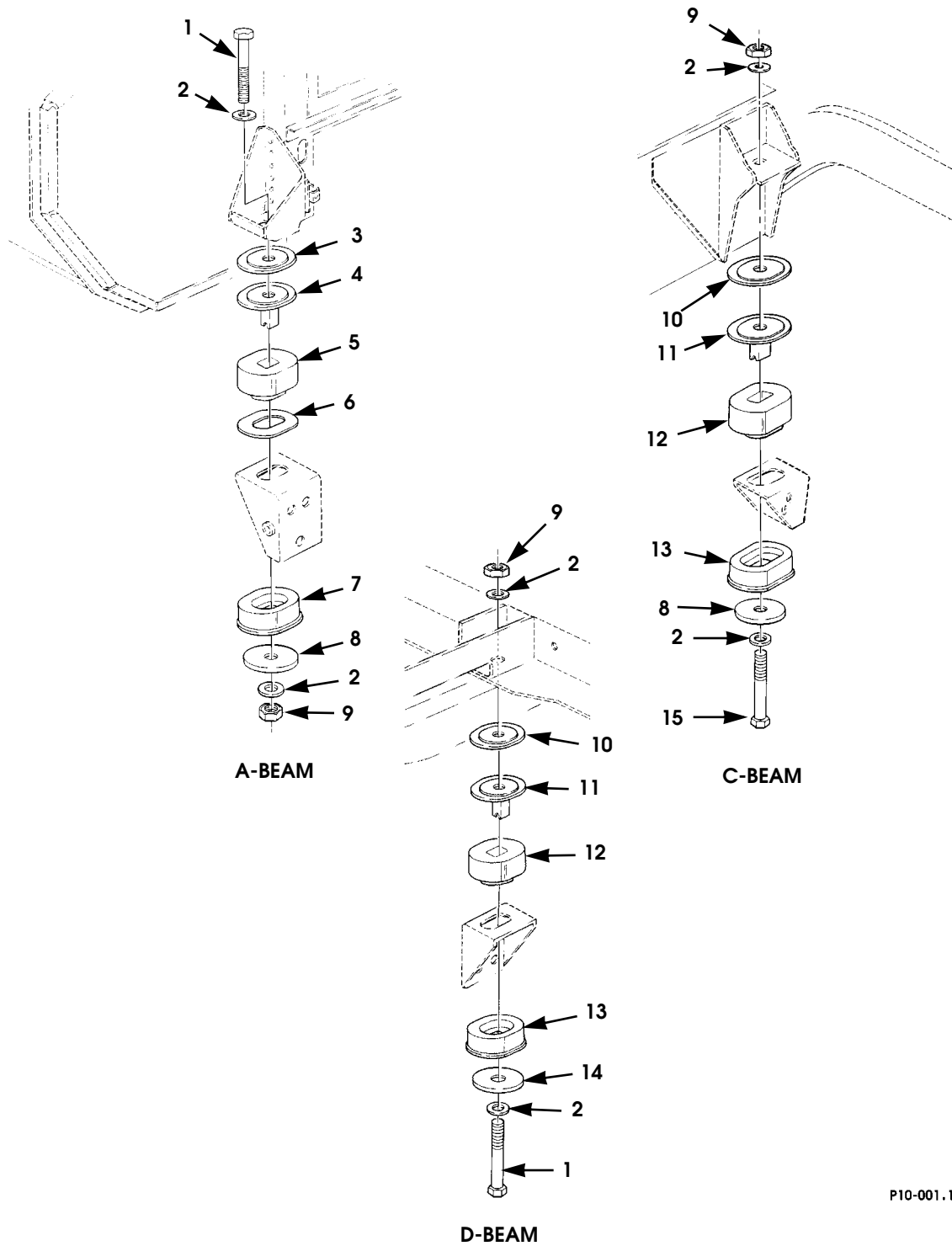

P10-001.1

Figure 10-1. Body Mounting Components.

# 2001 HUMMER PARTS CATALOG

**BODY 10-3**

ITEM	PART NUMBER	DESCRIPTION	QTY
		<b>Figure 10-1. Body Mounting Components.</b>	
1	N/S	BOLT, L.H., 5/8 - 11 x 4 1/4, Gr8, A-beam body mount.	1
1	N/S	BOLT, R.H., 5/8 - 11 x 4 3/4, Gr8, A-beam body mount	1
1	N/S	BOLT, 5/8 - 11 x 5, Gr8, D-beam body mount . . . . .	2
2	N/S	WASHER, flat, hardened, 5/8, ZN. . . . .	12
3	12469090-2	SPACER, body mount, 'A' . . . . .	2
4	12339249 1	SLEEVE ASSEMBLY, body cushion . . . . .	2
5	12339244 1	CUSHION ASSEMBLY, body, upper . . . . .	2
6	6011129	GASKET, body mount, "A" . . . . .	2
7	12339247 1	CUSHION ASSEMBLY, body, lower . . . . .	2
8	12339248 2	SPACER, mount, R.H. . . . .	2
9	12339248 3	SPACER, mount, L.H. . . . .	2
9	N/S	LOCKNUT, 5/8 - 11, Gr8 . . . . .	6
10	12469090-1	SPACER, body mount, 'C' . . . . .	4
11	12339249 2	SLEEVE ASSEMBLY, body cushion . . . . .	4
12	12339244 3	CUSHION ASSEMBLY, body, upper . . . . .	4
13	12339247 3	CUSHION ASSEMBLY, body, lower . . . . .	4
14	12339248 1	SPACER, body mount . . . . .	2
15	N/S	BOLT, 5/8 - 11 x 5, Gr8, C-beam body mount, L.H. . . . .	1
15	N/S	BOLT, 5/8 - 11 x 4 3/4, Gr8, C-beam body mount, R.H.	1

# 2001 HUMMER PARTS CATALOG

## 10-4 BODY

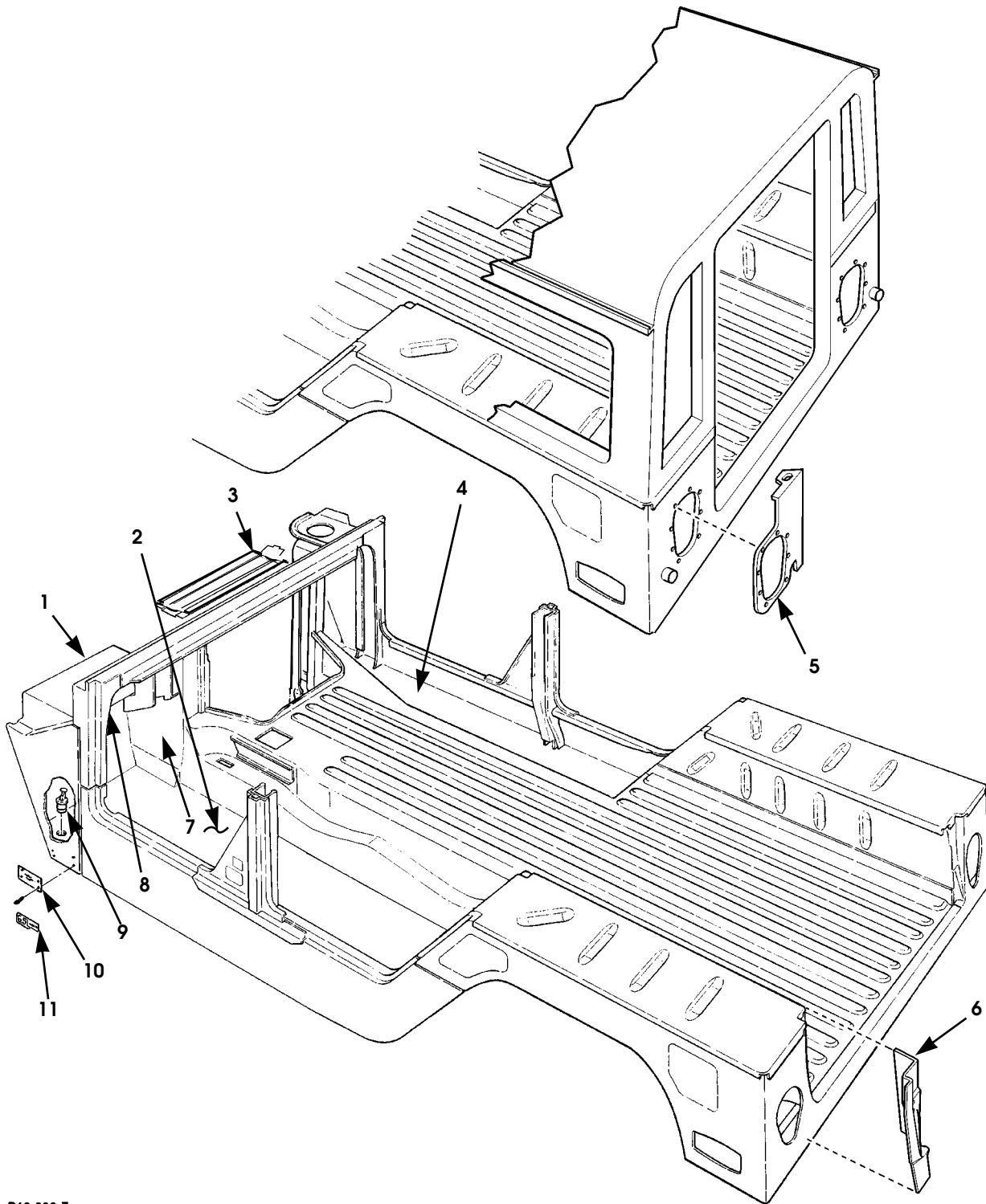

P10-002.7

Figure 10-2. Body Assembly

# 2001 HUMMER PARTS CATALOG

## BODY 10-5

ITEM	PART NUMBER	DESCRIPTION	QTY
		<b>Figure 10-2. Body Assembly</b>	
1	6010304P	BODY ASSEMBLY, basic riveted. . . . .	1
2	6003490P	PANEL, footwell, L.H. . . . .	1
3	6010376P	CLOSEOUT PANEL, A-beam. . . . .	1
4	6003535P	PANEL, footwell, R.H. . . . .	1
5	6005439P	CLOSEOUT PANEL, wheelhouse, rear, LH . . . . .	1
		84	
5	6005440P	CLOSEOUT PANEL, wheelhouse, rear, RH. . . . .	1
		84	
6	12339992 2P	FILLER, wheelhouse, LH . . . . .	1
6	12339992 1P	FILLER, wheelhouse, RH . . . . .	1
7	6010009P	PANEL, cowl, inner, L.H. . . . .	1
8	12338732P	BRACKET, brake pedal mounting. . . . .	1
9	5939808	DRAIN PLUG, floor . . . . .	2
10	6003871	NAMEPLATE "HUMMER" . . . . .	2
11	6010747	EMBLEM, "TT4 - ABS" . . . . .	2
		NOTE 1: NOTE 1: CUT FROM 35' BULK ROLL PVC FOAM TAPE P/N 5937189.	

# 2001 HUMMER PARTS CATALOG

## 10-6 BODY

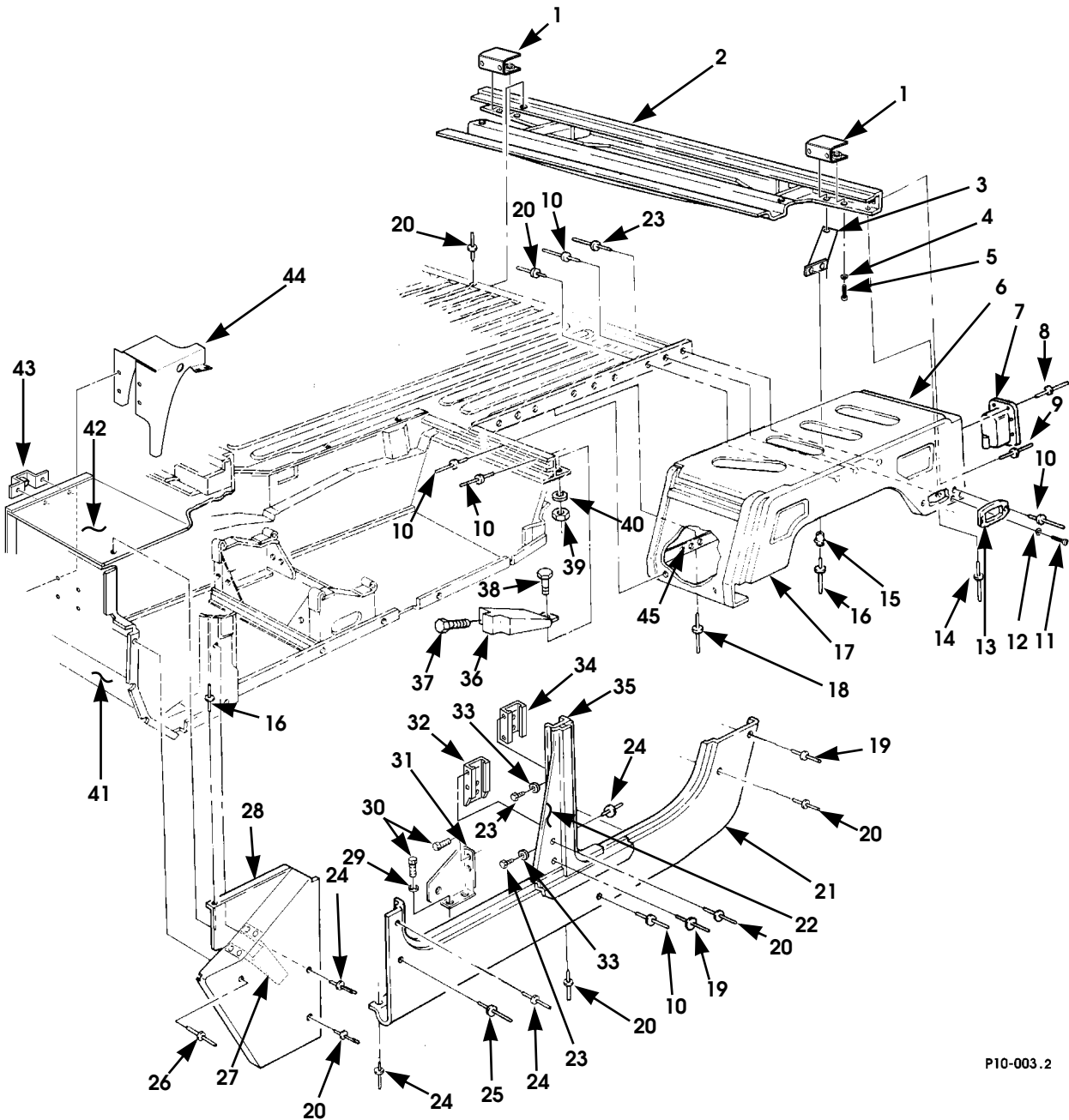

P10-003.2

Figure 10-3. Body Assembly Components, L.H.

# 2001 HUMMER PARTS CATALOG

**BODY 10-7**

ITEM	PART NUMBER	DESCRIPTION	QTY
		<b>Figure 10-3. Body Assembly Components, L.H.</b>	
1	12339008B1	HARNES COVER, D-beam . . . . .	2
2	WA12446928P	D-BEAM ASSEMBLY . . . . .	1
3	6007460B9	BRACE, L.H. wheelhouse . . . . .	1
4	N/S	LOCKWASHER, 1/4 . . . . .	4
5	N/S	BOLT, 1/4 - 20 x 1, Gr5. . . . .	4
6	WE12339701P	FENDER ASSEMBLY, L.H. . . . .	1
7	5938940	BRACKET, taillight housing . . . . .	1
8	6006452P1	RIVET, taillight housing . . . . .	8
9	N/S	RIVET, fender assembly, 3/16" dia. - 1/2" . . . . .	36
10	N/S	RIVET, side panel, 3/16" dia. - 1/4" . . . . .	52
11	N/S	BOLT, #10 - 24 x 3/4 . . . . .	2
12	N/S	WASHER, flat, #10 . . . . .	2
13	12338709	LIGHT HOUSING, fender assembly, side marker . . . . .	1
14	N/S	RIVET, fender assembly, 3/16" dia. - 7/16" . . . . .	17
15	NAS1080R06	COLLAR, grooved, fender assembly . . . . .	2
16	N/S	RIVET, fender assembly, 3/16" dia. x 1/4 - 3/8" . . . . .	2
17	6009345	OUTER PANEL, wheelhouse, L.H. . . . .	1
18	N/S	RIVET, 3/16" dia. - 5/16," fender assembly . . . . .	32
19	N/S	RIVET, side panel, 3/16" dia. - 5/16" . . . . .	3
20	N/S	RIVET, fender panel, 3/16" dia. - 1/4" . . . . .	21
21	WA123396981P	BODY SIDE ASSEMBLY, panel, L.H. . . . .	1
22	12340009 3P	•RABBET ASSEMBLY, B-pillar, L.H. . . . .	1
23	MS00090725 33	BOLT, 5/16 - 18 x 7/8, Gr5, CAD . . . . .	4
24	N/S	RIVET, body assembly, 3/16 dia. - 3/16" . . . . .	101
25	N/S	RIVET, side panel, 3/16" dia. - 3/16" . . . . .	7
26	N/S	RIVET, cowl panel, 3/16" dia. - 1/8" . . . . .	21
27	6001256P	BRACKET ASSEMBLY, hood latch. . . . .	1
28	5939202P	PANEL, cowl, L.H. outer. . . . .	1
29	N/S	WASHER, flat, 1/4, CAD, seat belt mount . . . . .	2
30	N/S	BOLT, 1/4 - 20 x 5/8, CAD, seat belt mount. . . . .	4
31	12339988 1	MOUNTING BRACKET, seat belt, L.H., front. . . . .	1
32	6004811B9	BRACKET, lower, L.H., B-pillar . . . . .	1
33	N/S	WASHER, flat, 5/16, CAD . . . . .	4
34	WA12342372	BRACKET, upper, L.H., B-pillar. . . . .	1
35	6003456P	REINFORCEMENT, B-pillar, L.H. . . . .	1
36	12339025 1	SEAL ASSEMBLY, cargo floor, L.H. . . . .	1
37	N/S	SCREW, tapping, phcr, #10 - 16 x 7/8, Phos . . . . .	2
38	N/S	SCREW, #10 - 24 x 3/4, seal assembly. . . . .	1
39	N/S	LOCKNUT, nylon insert, #10 - 24, seal assembly. . . . .	1
40	N/S	WASHER, flat, #10, CAD, seal assembly . . . . .	1
41	6007204P	PANEL, cowl front, L.H. . . . .	1
42	6010007P	PANEL, cowl top, A-pillar, L.H. . . . .	1
43	6005498B9	BRACKET, heated windshield fuse mounting . . . . .	1
44	12338732P	BRACKET, brake pedal mounting. . . . .	1
45	12338764 1	PANEL, wheelhouse inner, L.H. . . . .	1



# 2001 HUMMER PARTS CATALOG

## 10-8 BODY

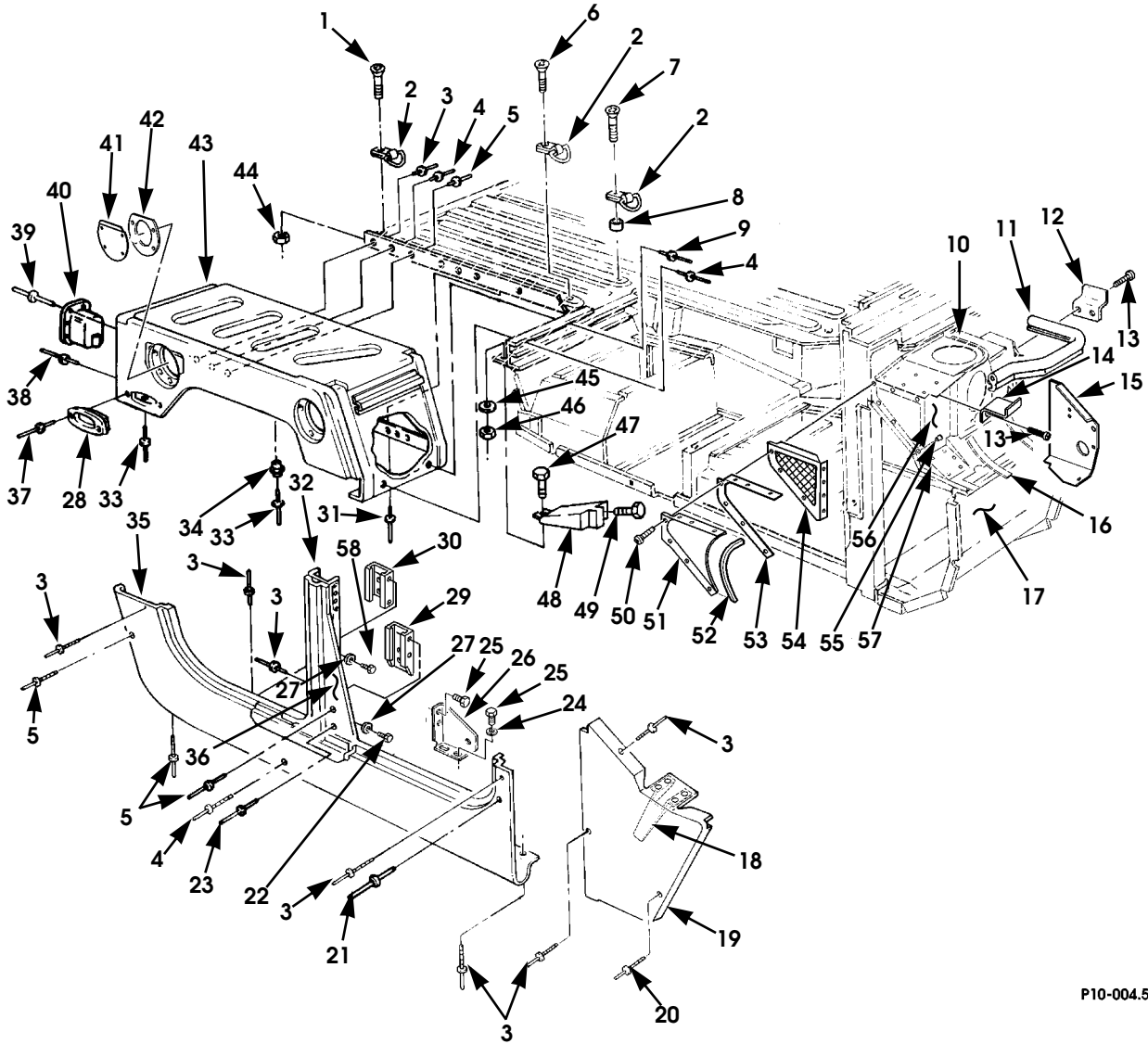

P10-004.5

Figure 10-4. Body Assembly Components, R.H.

# 2001 HUMMER PARTS CATALOG

**BODY 10-9**

ITEM	PART NUMBER	DESCRIPTION	QTY
		<b>Figure 10-4. Body Assembly Components, R.H.</b>	
1	N/S	SCREW, countersunk, 1/2 -13 x 1, CAD, D-ring, cargo area, rear edge . . . . .	3
		83, 84, 89, 90	
2	6005425	D-RING TIEDOWN. . . . .	11
		83, 84, 89, 90	
2	6005425	D-RING TIEDOWN. . . . .	8
		91	
3	N/S	RIVET, body assembly, 3/16" dia. x 3/16" . . . . .	130
4	N/S	RIVET, body assembly, 3/16" dia. x 9/16" . . . . .	57
5	N/S	RIVET, body assembly, 3/16" dia. x 1/4" . . . . .	21
6	N/S	SCREW, countersunk, 1/2 -13 x 1 3/4, CAD, D-ring, cargo area, center, no carpet . . . . .	4
		83, 89, 90	
6	N/S	SCREW, countersunk, 1/2 -13 x 2, CAD, D-ring, cargo area, center, with carpet . . . . .	4
		84, 91	
7	N/S	SCREW, countersunk, 1/2 -13 x 1 3/4, CAD, D-ring, between rear doors, no carpet. . . . .	4
		89	
7	N/S	SCREW, countersunk, 1/2 -13 x 2, CAD, D-ring, between rear doors, with carpet . . . . .	4
		83, 84, 90, 91	
8	6006451	SPACER, D-ring, through carpet front, 3/4" . . . . .	4
		83, 84, 90, 91	
8	6005426B2	SPACER, D-ring, through carpet rear, 7/8" . . . . .	4
		84, 91	
9	N/S	RIVET, fender assembly, 3/16" dia. x 7/16" . . . . .	17
10	6003137P	TOP PANEL ASSEMBLY, air intake chamber . . . . .	1
11	12338832 1	SEAL, body assembly, air box . . . . .	1
12	12338814B1	BRACKET, seal, air box . . . . .	1
13	N/S	SCREW, tapping, #10 - 16 x 1/2, ZN, seal bracket. . . . .	4
14	12340869	BRACKET, seal, front, air box . . . . .	1
15	6009311P	PANEL, COWL SIDE, R.H., inner . . . . .	1
16	12338712P	SUPPORT, air cleaner. . . . .	2
17	6009318P	PANEL, cowl front, R.H. . . . .	1
18	6001256P	BRACKET, hood latch, R.H. . . . .	1
19	6003135P	COWL PANEL, R.H. . . . .	1
20	N/S	RIVET, cowl panel, 3/16" dia. x 1/8" . . . . .	5
21	N/S	RIVET, side panel, 3/16" dia. x 3/16" . . . . .	3
22	N/S	BOLT, 5/16 - 8 x 7/8, Gr8, CAD . . . . .	4
23	N/S	RIVET, side panel, 3/16" dia. x 5/16" . . . . .	7

# 2001 HUMMER PARTS CATALOG

## 10-10 BODY

ITEM	PART NUMBER	DESCRIPTION	QTY
<b>Figure 10-4.</b>			
<b>Body Assembly Components, R.H. (Cont'd)</b>			
24	MS27183 21	WASHER, seat belt mount . . . . .	2
25	N/S	SCREW, 1/4 - 20 x 5/8, CAD, seat belt mount . . . . .	4
26	12339988 2	BRACKET, seat belt, front R.H. . . . .	1
27	N/S	WASHER, flat, 5/16, CAD. . . . .	4
28	12338709	LIGHT HOUSING, fender assembly . . . . .	1
29	6004836B9	BRACKET, lower, R.H., B-pillar . . . . .	1
30	WA12342372	BRACKET, upper, R.H., B-pillar. . . . .	1
31	N/S	RIVET, fender assembly, 3/16" x 5/8" . . . . .	16
32	6003457P	REINFORCEMENT, B-pillar, R.H. . . . .	1
33	N/S	RIVET, fender assembly, 3/16" x 3/16" . . . . .	2
34	N/S	COLLAR, grooved, fender assembly, 3/16" . . . . .	2
35	WA123396982P	BODY SIDE ASSEMBLY, panel, R.H. . . . .	1
36	12340009 4P	•RABBET ASSEMBLY, B-pillar, RH . . . . .	1
37	N/S	RIVET, light housing . . . . .	2
38	N/S	RIVET, fender assembly, 3/16" x 1/2" . . . . .	18
39	6006452	RIVET, taillight housing . . . . .	8
40	5938940	BRACKET, taillight housing . . . . .	1
41	6007237P	COVER, auxiliary tank filler hole, SEE NOTE 1 . . . . .	1
42	6007247	GASKET, auxiliary tank filler hole cover, SEE NOTE 1 . . . . .	1
43	WD12339707P	FENDER ASSEMBLY, R.H. . . . .	1
44	6007708	WELDNUT, D-ring . . . . .	11
45	N/S	WASHER, flat, #10, CAD, seal assembly. . . . .	1
46	N/S	LOCKNUT, #10 - 24, CAD, seal assembly. . . . .	1
47	N/S	SCREW, #10 - 24 x 3/4, CAD, seal assembly. . . . .	1
48	12339025 2	SEAL ASSEMBLY, body, R.H. . . . .	1
49	N/S	SCREW, ph tapping, #10 - 16 x 7/8, Phos . . . . .	2
50	6008857	SCREW. . . . .	7
51	6008703P	SCOOP, air intake . . . . .	1
52	N/S	EDGE GUARD, 9.5" long, air intake scoop, SEE NOTE 2. . . . .	1
53	6009176	GASKET, air intake . . . . .	1
54	6008699P	PANEL, air intake. . . . .	1
55	5939334	NUT INSERT . . . . .	7
56	6003409P	PANEL, air intake support . . . . .	1
57	6009313	PANEL, cowl, top, R.H. . . . .	1
58	MS90725 33	BOLT, 5/16 - 18 x 7/8, Gr5, CAD . . . . .	4
NOTE 1: FOR USE ON FLEET VEHICLES WITHOUT AUXILIARY FUEL TANK			
NOTE 2: CUT TO 9.5" LENGTH FROM 24" EDGE GUARD 5745010.			



# 2001 HUMMER PARTS CATALOG

## 10-12 BODY

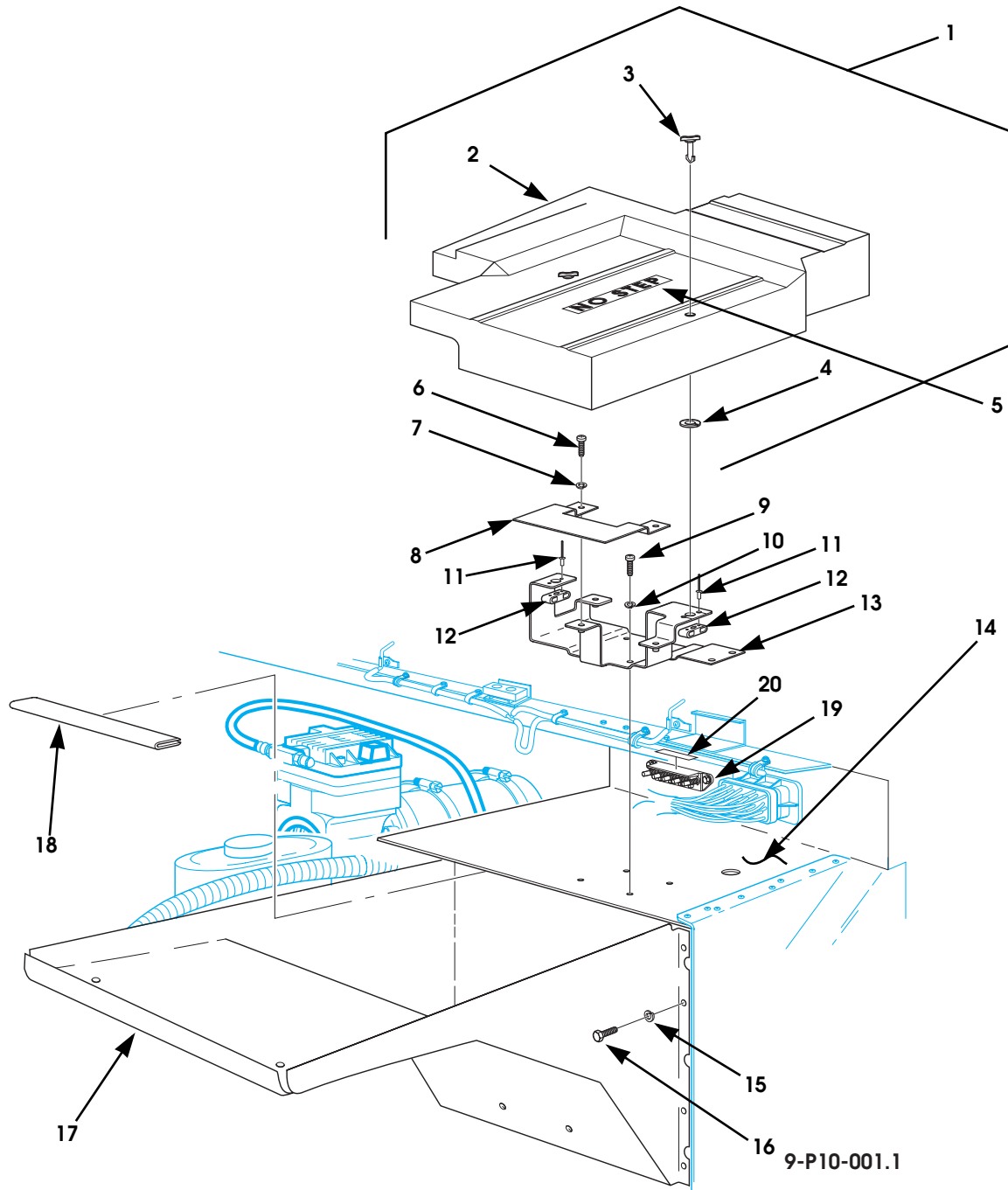

Figure 10-5. Windshield Washer Reservoir Mounting Support.

# 2001 HUMMER PARTS CATALOG

**BODY 10-13**

ITEM	PART NUMBER	DESCRIPTION	QTY
		<b>Figure 10-5. Windshield Washer Reservoir Mounting Support.</b>	
1	6010019L	COVER ASSEMBLY, L.H. cowl components . . . . .	1
2	S.I.A.	•COVER, L.H. cowl components . . . . .	1
3	6010326	•STUD, L.H. cowl cover fastening . . . . .	2
4	6010327	•RETAINER, L.H. cowl cover fastening stud . . . . .	2
5	12339055	DECAL, "NO STEP" . . . . .	1
6	N/S	SCREW, #10 - 24 x 3/4 . . . . .	3
7	N/S	LOCKWASHER, #10. . . . .	3
8	6010324B9	RETAINER, ABS ECU housing . . . . .	1
9	N/S	BOLT, phcr, #10 - 24 x 5/8 . . . . .	4
10	N/S	LOCKWASHER, #10. . . . .	4
11	M24243/1 A404	RIVET, blind . . . . .	2
12	6010264	RECEPTACLE, stud 12. . . . .	2
13	6010217	BRACKET ASSEMBLY, distribution box mounting . . . . .	1
14	6010007P	PANEL, cowl top, L.H. . . . .	1
15	N/S	LOCKWASHER, 5/16. . . . .	7
16	N/S	BOLT, 5/16 - 18 x 1 . . . . .	7
17	6010149B9	BRACKET, windshield washer reservoir mounting. . . . .	2
18	N/S	EDGE GUARD, 17" long, SEE NOTE 2. . . . .	1
19	6007329	JUNCTION BLOCK . . . . .	1
20	6010648	DECAL, "12V" (Arabic) . . . . .	1
20	6010455	DECAL, "12V"/BATTERY POWER . . . . .	1
		NOTE 1: SEE PAGE 12-18 FOR WINDSHIELD WASHER RESERVOIR, P/N 6010284	
		NOTE 2: CUT TO LENGTH FROM BULK EDGE GUARD P/N 6006218	

# 2001 HUMMER PARTS CATALOG

## 10-14 BODY

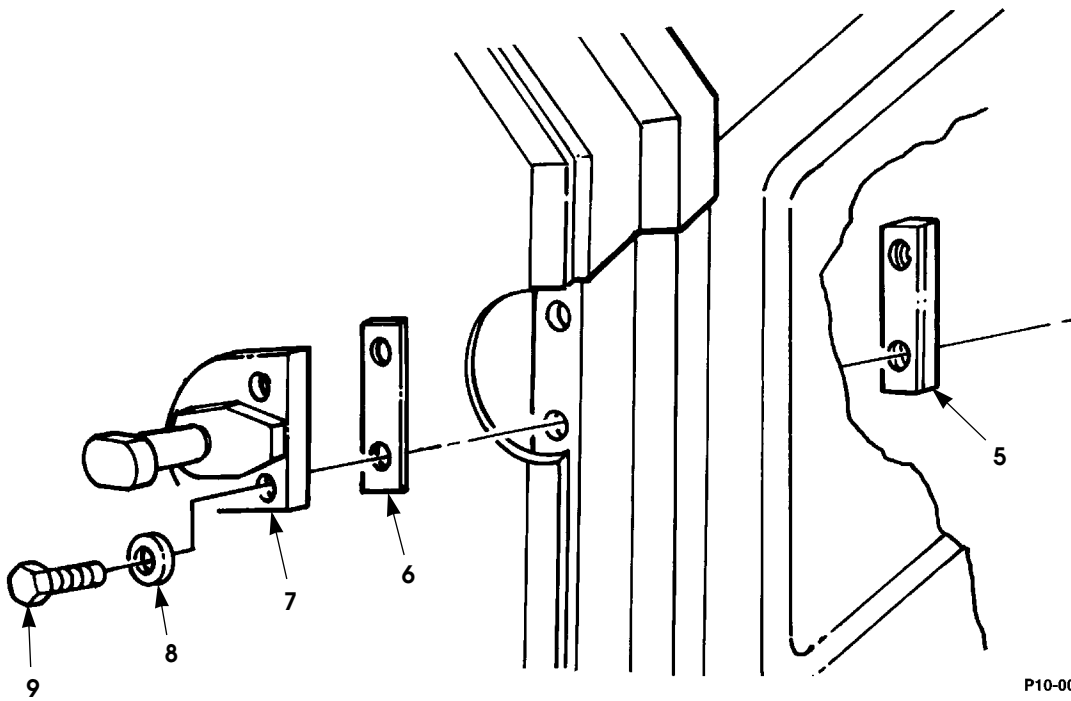
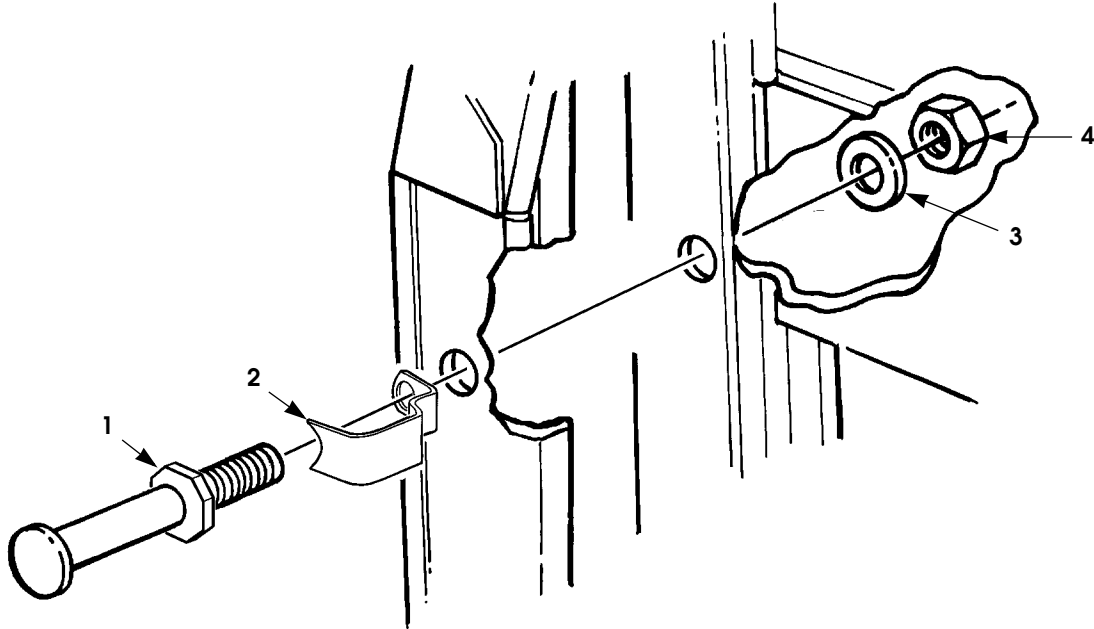

P10-005.1

Figure 10-6. Door Striker Assemblies, Front and Rear.

# 2001 HUMMER PARTS CATALOG

**BODY 10-15**

ITEM	PART NUMBER	DESCRIPTION	QTY
		<b>Figure 10-6. Door Striker Assemblies, Front and Rear.</b>	
1	6000392P2	STRIKER ASSEMBLY, front . . . . .	2
		83,84, 90,	
1	6004539P2	STRIKER ASSEMBLY, front . . . . .	2
		89	
2	6006438	GUARD, striker . . . . .	2
3	6001200P2	WASHER . . . . .	2
4	N/S	LOCKNUT, 1/2 - 20, Gr8 . . . . .	2
5	6003485	PLATE BACKING, rear. . . . .	2
6	5939591	PLATE BACKING, front . . . . .	2
7	5939655P2	STRIKER ASSEMBLY, rear . . . . .	2
8	9424257P2	LOCKWASHER . . . . .	4
9	N/S	BOLT, 1/4 - 20 x 1 1/4, Gr8, CAD . . . . .	4



# 2001 HUMMER PARTS CATALOG

## 10-16 BODY

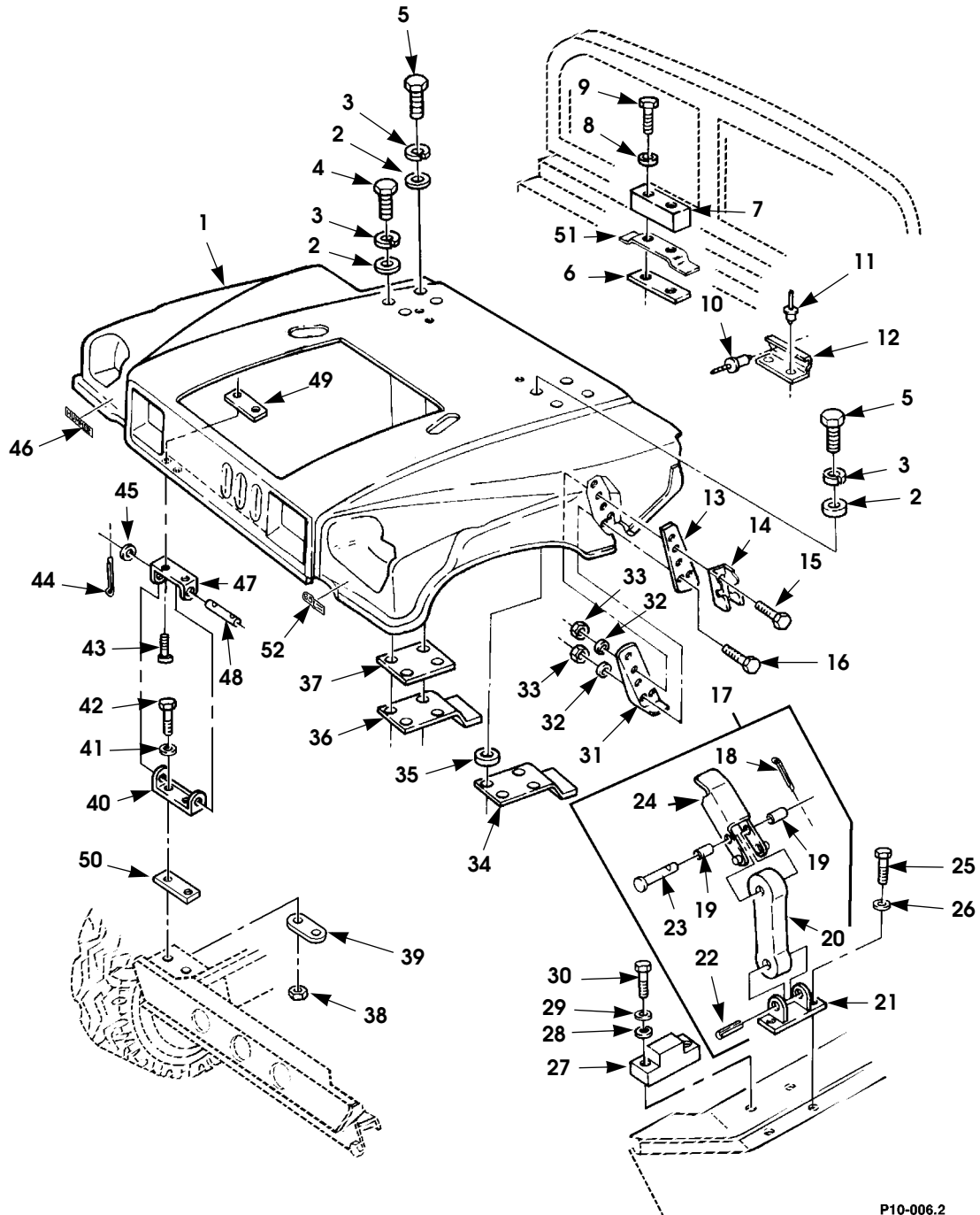

Figure 10-7. Hood Assembly and Mounting Hardware.

# 2001 HUMMER PARTS CATALOG

## BODY 10-17

ITEM	PART NUMBER	DESCRIPTION	QTY
		<b>Figure 10-7. Hood Assembly and Mounting Hardware.</b>	
1	WA12338940P	HOOD, engine compartment . . . . .	1
2	N/S	WASHER, flat, 1/4, CAD . . . . .	8
3	N/S	LOCKWASHER, med, 1/4, ZN, retainer bracket . . . . .	8
4	N/S	BOLT, 1/4 - 20 x 1 1/2, Gr8, CAD, retainer bracket . . . . .	2
5	N/S	BOLT, 1/4 - 20 x 3/4, Gr5, CAD, retainer bracket, L.H. . . . .	6
6	12338882P3	PLATE, center hood stop, tapping . . . . .	1
7	6002012	BUMPER, center hood . . . . .	1
8	12339433	WASHER, hood stop center . . . . .	2
9	N/S	BOLT, 1/4 - 20 x 1, Gr8, CAD, hood stop . . . . .	4
10	M7885/2 6-4	RIVET, hood retainer bracket . . . . .	4
11	12339355 2	RIVET, hood retainer bracket . . . . .	4
12	5939715	BRACKET, hood retainer, "A" beam . . . . .	2
13	12338883B4	PLATE, hood latch . . . . .	2
14	12338908B4	BRACKET, hood latch, side . . . . .	2
15	N/S	BOLT, 1/4 - 20 x 1 1/8, Gr8, hood latch bracket . . . . .	10
16	N/S	BOLT, 1/4 - 20 x 7/8, Gr8, hood latch bracket . . . . .	6
17	12338909B4	LATCH ASSEMBLY, hood . . . . .	2
18	MS24665 134	•COTTER PIN, hood latch . . . . .	2
19	12338886P3	•ROLLER, hood latch . . . . .	2
20	12338889	•STRAP, hood latch . . . . .	1
21	12338880B4	•BASE, hood latch . . . . .	1
22	9419982	•PIN, hood latch, spring hood . . . . .	1
23	12338894P3	•PIN, hood latch . . . . .	1
24	12338891B4	•LATCH, hood release . . . . .	1
25	N/S	BOLT, hood latch, 1/4 - 20 x 1 1/8, Gr5, CAD . . . . .	4
26	N/S	WASHER, flat, hard, 1/4, type B, ZN . . . . .	4
27	12338896	STOP, hood side . . . . .	2
28	12339433P2	WASHER, hood side stop . . . . .	4
29	N/S	LOCKWASHER, med, 1/4, ZN, center . . . . .	4
30	N/S	BOLT, 1/4 - 20 x 1 5/8, Gr5, hood stop . . . . .	4
31	12338905P3	BRACKET, hood latch stop . . . . .	2
32	N/S	WASHER, flat, hard, 1/4, ZN, hood latch . . . . .	10
33	N/S	LOCKNUT, 1/4 - 20, Gr8 . . . . .	5
34	5939716B2	BRACKET, hood retainer, L.H. . . . .	1
35	5939805B2	SPACER, retainer bracket . . . . .	2
36	5939717B2	BRACKET, hood retainer, R.H. . . . .	1
37	5939718B2	SPACER, retainer bracket . . . . .	1
38	N/S	NUT, 7/16 - 14, Gr8, CAD, lower hood hinge . . . . .	4
39	12338879P3	SPACER, lower hinge . . . . .	2
40	12338900B5	HINGE HALF, lower hood . . . . .	2
41	N/S	WASHER, flat, hardened, 7/16, ZN, lower hinge . . . . .	4
42	N/S	BOLT, 7/16 - 14 x 2, Gr8, CAD, lower hinge . . . . .	4

# 2001 HUMMER PARTS CATALOG

## 10-18 BODY

ITEM	PART NUMBER	DESCRIPTION	QTY
		<b>Figure 10-7. Hood Assembly and Mounting Hardware. (Cont'd)</b>	
43	N/S	BOLT, 3/8 - 16 x 2, Gr5, CAD . . . . .	4
44	N/S	COTTER PIN, hood hinge, 3/32" x 1/2" CAD . . . . .	4
45	N/S	WASHER, flat, hardened, 3/8, type B, lwr hood hinge pin	4
46	6003871	NAME PLATE "HUMMER" . . . . .	1
47	12338897B5	HINGE HALF, upper hood . . . . .	2
48	12338893	PIN, hood hinge halves . . . . .	2
49	12339306	PLATE, upper hood hinge . . . . .	2
50	6007365B5	SPACER, Hinge to Hood. . . . .	2
51	12338649P	BRACKET, hood center stop . . . . .	1
52	6008595	EMBLEM "6.5L TURBO DIESEL" . . . . .	1



# 2001 HUMMER PARTS CATALOG

## 10-20 BODY

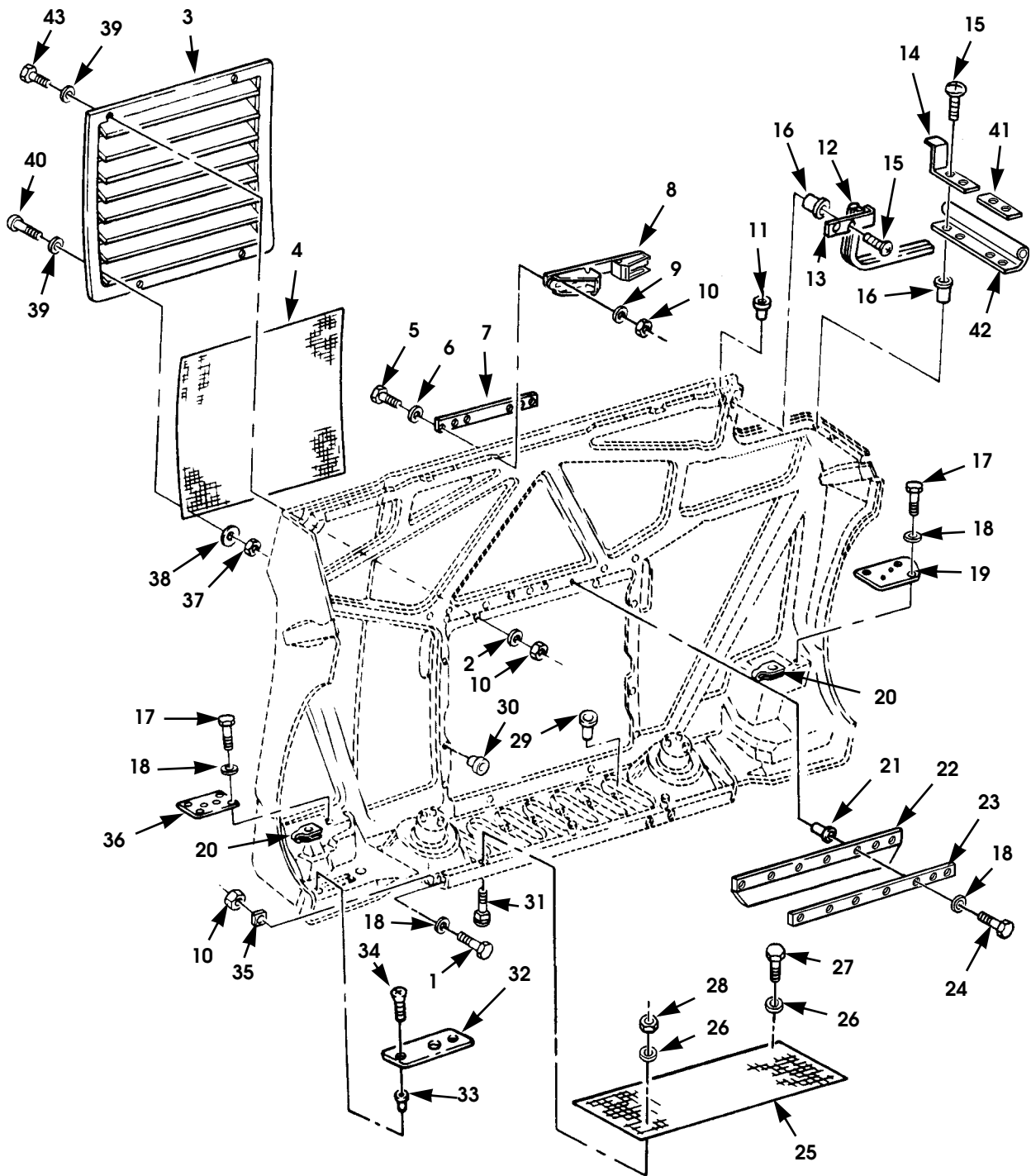

P10-007

Figure 10-8. Hood Assembly, Grille, and Related Parts.

# 2001 HUMMER PARTS CATALOG

**BODY 10-21**

ITEM	PART NUMBER	DESCRIPTION	QTY
		<b>Figure 10-8. Hood Assembly, Grille, and Related Parts.</b>	
1	N/S	BOLT, buttonhead, 1/4 - 20 x 1, Gr8 . . . . .	6
2	N/S	WASHER, flat, 1/4, CAD, hood grille . . . . .	12
3	6007257	GRILLE, hood . . . . .	1
4	6011077	SCREEN, hood grille, top . . . . .	1
5	N/S	BOLT, 1/4 - 20 x 1 1/8, Gr8, CAD, hood stop guide . . .	6
6	N/S	WASHER, flat, hardened, 1/4, ZN, hood stop guide . . .	6
7	12338903P3	PLATE, hood stop guide . . . . .	1
8	6007349	BRACKET, hood stop guide . . . . .	1
9	N/S	WASHER, flat, hardened, 1/4, ZN, hood stop guide . . .	6
10	N/S	LOCKNUT, 1/4 - 20, Gr8, hood stop guide and crossbar	12
11	M5501/7F4	PLUG, inner hood assembly . . . . .	4
12	6002673	SEAL, hood . . . . .	1
13	6001745	RETAINER, seal . . . . .	1
14	6001746	RETAINER, seal . . . . .	1
15	160057	SCREW . . . . .	4
16	12339397 1	WELLNUT . . . . .	4
17	N/S	BOLT, 1/4 - 20 x 3/4, Gr5, CAD, composite light cover .	7
18	N/S	WASHER, flat, 1/4, CAD . . . . .	16
19	EC12338884P3	COVER, composite light, R.H. . . . .	1
20	12339425	SPEED NUT, composite light cover . . . . .	7
21	12339397 4	WELLNUT, hood seal. . . . .	9
22	WA12338911	SEAL, center hood . . . . .	1
23	12338885P3	RETAINER, hood seal . . . . .	1
24	N/S	BOLT, 1/4 - 20 x 1, Gr5, CAD, hood seal retainer . . . . .	9
25	6011078	GUARD, hood and grille, front . . . . .	1
26	N/S	WASHER, flat, hardened, 3/8, type B, front hood screen .	6
27	N/S	SCREW, 5/16 - 18 x 1, Gr5, CAD . . . . .	3
28	N/S	NUT, 5/16 - 18, Gr8, CAD, front hood screen . . . . .	3
29	12339397 5	WELLNUT, front hood screen. . . . .	3
30	12338887 2	PLUG, hood assembly, tapered, grille . . . . .	6
31	12339434P2	BOLT, carriage . . . . .	3
32	5935690	PANEL, inner hood, access . . . . .	2
33	12339998 1	PLUSNUT, inner hood panel . . . . .	4
34	N/S	SCREW, phcr, #10 - 32 x 1/2, inner hood panel . . . . .	4
35	12338892	PLATE, hood crossbar, spacer. . . . .	2
36	12338906P3	COVER, composite light, L.H. . . . .	1
37	N/S	LOCKNUT, hood grille screen, #10-24 Gr A CAD. . . . .	6
38	12339432P2	WASHER, hood grille screen . . . . .	12
39	N/S	WASHER, flat, hood grille screen, #10 S.A.E. CAD . . . . .	6
40	N/S	SCREW, hood grille screen, #10-24 x .87" ph mach . . .	6
41	6005171	RETAINER, hood seal . . . . .	1
42	6005170	SEAL, hood, rear, R.H. . . . .	1
43	N/S	SCREW, buttonhead, 1/4 - 20 x 1 . . . . .	6

# 2001 HUMMER PARTS CATALOG

## 10-22 BODY

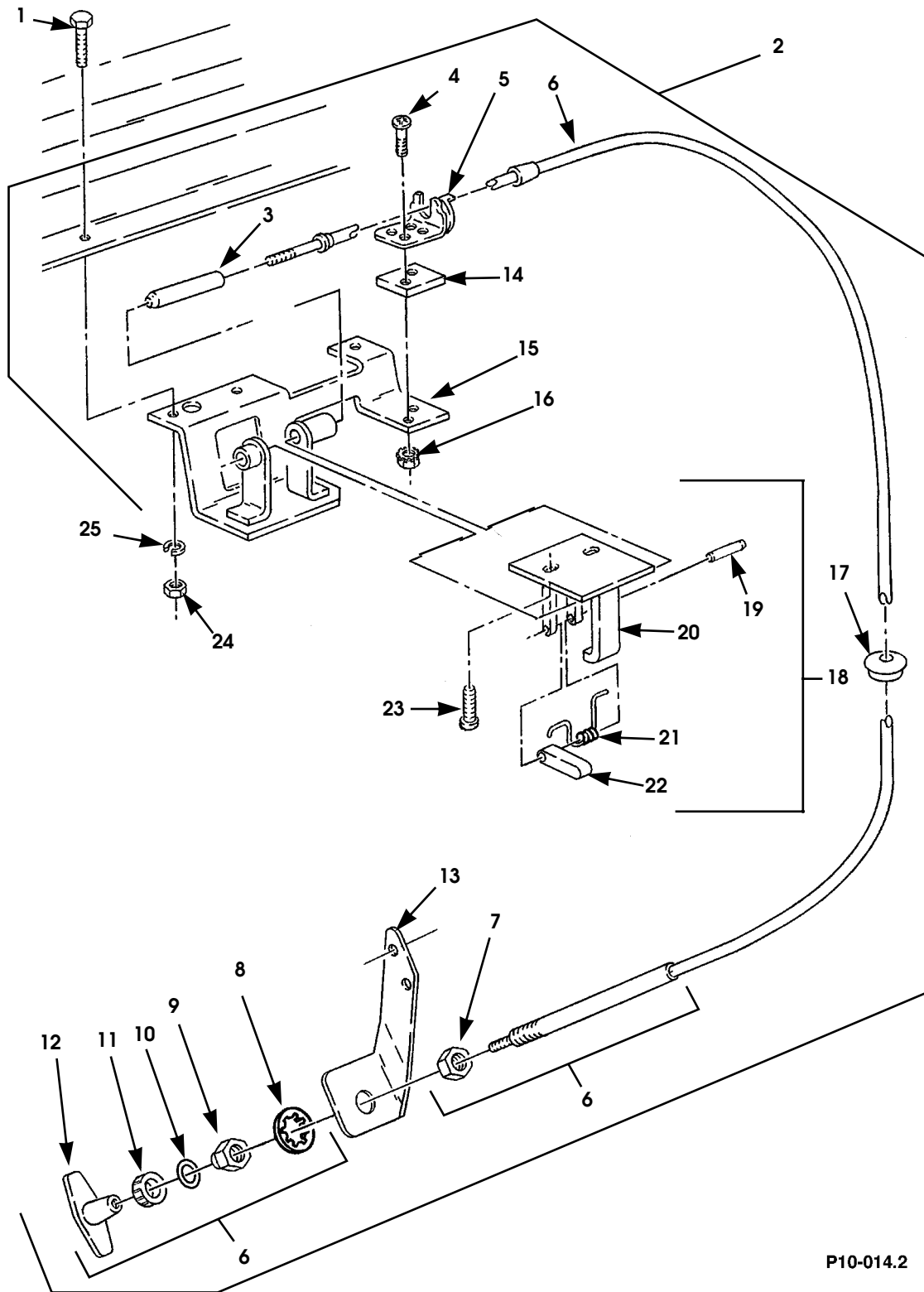

Figure 10-9. Hood Release.

# 2001 HUMMER PARTS CATALOG

**BODY 10-23**

ITEM	PART NUMBER	DESCRIPTION	QTY
		<b>Figure 10-9. Hood Release.</b>	
1	N/S	BOLT, 1/4 - 20 x 3/4, Gr5, CAD . . . . .	3
2	5743863	KIT, hood lock. . . . .	1
3	6005383	•LOCKPIN, hood latch . . . . .	1
4	S.I.K.	•SCREW, phcr, #8 - 32 x 3/4. . . . .	4
5	6005401	•BRACKET, cable clamp . . . . .	1
6	6005389	•CABLE ASSEMBLY . . . . .	1
7	S.I.A.	••NUT . . . . .	1
8	S.I.A.	••LOCKWASHER . . . . .	1
9	S.I.A.	••LOCKNUT . . . . .	1
10	6006128	••O-RING . . . . .	1
11	S.I.A.	••SPACER . . . . .	1
12	S.I.A.	••T-HANDLE . . . . .	1
13	6005390	•BRACKET, cable mounting . . . . .	1
14	6005388	•SPACER, cable mounting clamp . . . . .	1
15	6005395	•BRACKET ASSEMBLY. . . . .	1
16	N/S	•NUT AND LOCKWASHER ASSEMBLY, #8 - 32, keps . . . .	2
17	12338999	•GROMMET . . . . .	1
18	6005536	•LATCH ASSEMBLY, hood . . . . .	1
19	6005613	••PIN . . . . .	1
20	S.I.A.	••LATCH. . . . .	1
21	6005386	••SPRING, lock arm . . . . .	1
22	6005385	••ARM LOCK . . . . .	1
23	N/S	SCREW, tapping, 1/4 - 28 x 1, ZN. . . . .	2
24	N/S	NUT, 1/4-20, ZN . . . . .	3
25	N/S	LOCKWASHER, med, 1/4, ZN. . . . .	5



# 2001 HUMMER PARTS CATALOG

## 10-24 BODY

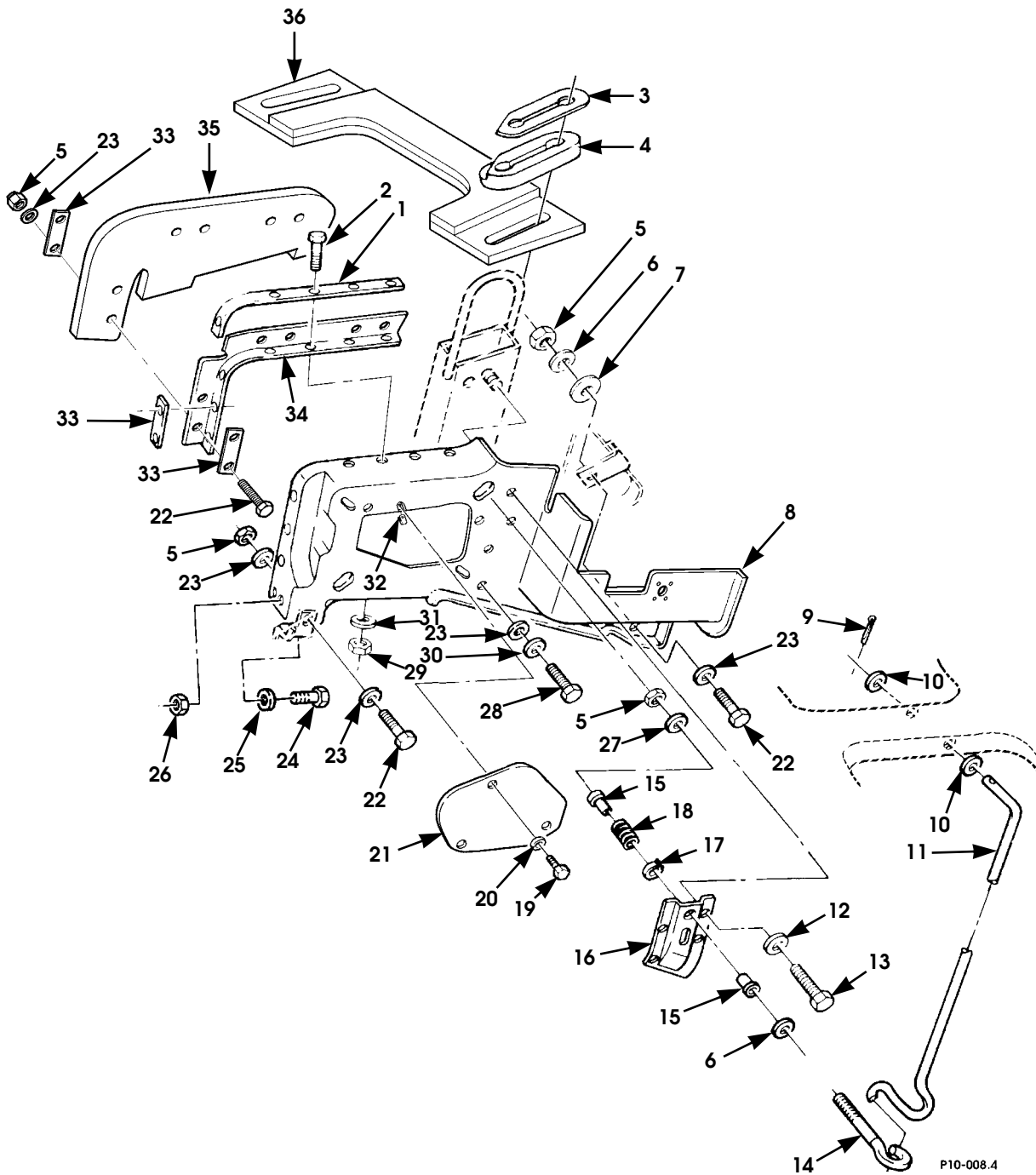

Figure 10-10. Splash Shield (Left Hand) and Hood Prop Rod.

# 2001 HUMMER PARTS CATALOG

**BODY 10-25**

ITEM	PART NUMBER	DESCRIPTION	QTY
		<b>Figure 10-10. Splash Shield (Left Hand) and Hood Prop Rod.</b>	
1	12338630P3	RETAINER, splash shield seal . . . . .	1
2	N/S	SCREW, #10 - 24 x 3/4 . . . . .	7
3	6008043	COVER PLATE, airlift bracket seal, engine seal . . . . .	1
4	12342357	SEAL, airlift bracket, L.H. . . . .	1
5	N/S	LOCKNUT, 5/16 - 18, Gr8, prop rod eyebolt . . . . .	3
6	N/S	WASHER, flat, hardened, 5/16, ZN, prop rod eyebolt . . . . .	2
7	9421128	WASHER, splash shield . . . . .	1
8	6010083B1	SPLASH SHIELD, L.H . . . . .	1
9	N/S	COTTER PIN, 3/32" x 3/4", prop rod . . . . .	1
10	N/S	WASHER, flat, hardened, 3/8. . . . .	3
11	12338915	ROD, hood prop . . . . .	1
12	N/S	LOCKWASHER, med, 1/4, ZN, prop rod bracket . . . . .	4
13	N/S	SCREW, tapping, 1/4 - 28 x 1. . . . .	4
14	12339435	EYEBOLT, hood prop rod . . . . .	1
15	12338895	BUSHING, eye bolt . . . . .	2
16	12338913	BRACKET, hood prop rod . . . . .	1
17	MS16624 2066	RETAINING RING, prop rod bracket bushing . . . . .	1
18	12338881P3	SPRING, prop rod eyebolt. . . . .	1
19	N/S	BOLT, #8 - 32 x 1 . . . . .	3
20	N/S	WASHER, #8. . . . .	3
21	12446770 1B2	PLATE COVER. . . . .	1
22	N/S	BOLT, 5/16 - 18 x 1, Gr5, CAD. . . . .	2
23	N/S	WASHER, flat, 5/16, CAD . . . . .	4
24	N/S	SCREW, 1/4 - 20 x 1 1/2, CAD . . . . .	1
25	N/S	WASHER, flat, 1/4, CAD . . . . .	1
26	N/S	LOCKNUT, 1/4 - 20 . . . . .	1
27	N/S	WASHER, flat, 5/16, CAD . . . . .	1
28	N/S	SCREW, tapping, 5/16 - 18 x 1. . . . .	1
29	N/S	LOCKNUT, #10 - 24, Gr8, CAD . . . . .	7
30	N/S	LOCKWASHER, med, 5/16, ZN . . . . .	1
31	N/S	WASHER, flat, #10, CAD . . . . .	7
32	N/S	SPRING NUT, #8 - 32 . . . . .	3
33	12338634 1P3	RETAINER, splash shield seal, L.H. . . . .	7
34	6007395	SEAL, splash shield, hood, L.H.. . . . .	1
35	6007251	SEAL, splash shield to hood . . . . .	1
36	6007250	SEAL, radiator-to-hood . . . . .	1

# 2001 HUMMER PARTS CATALOG

## 10-26 BODY

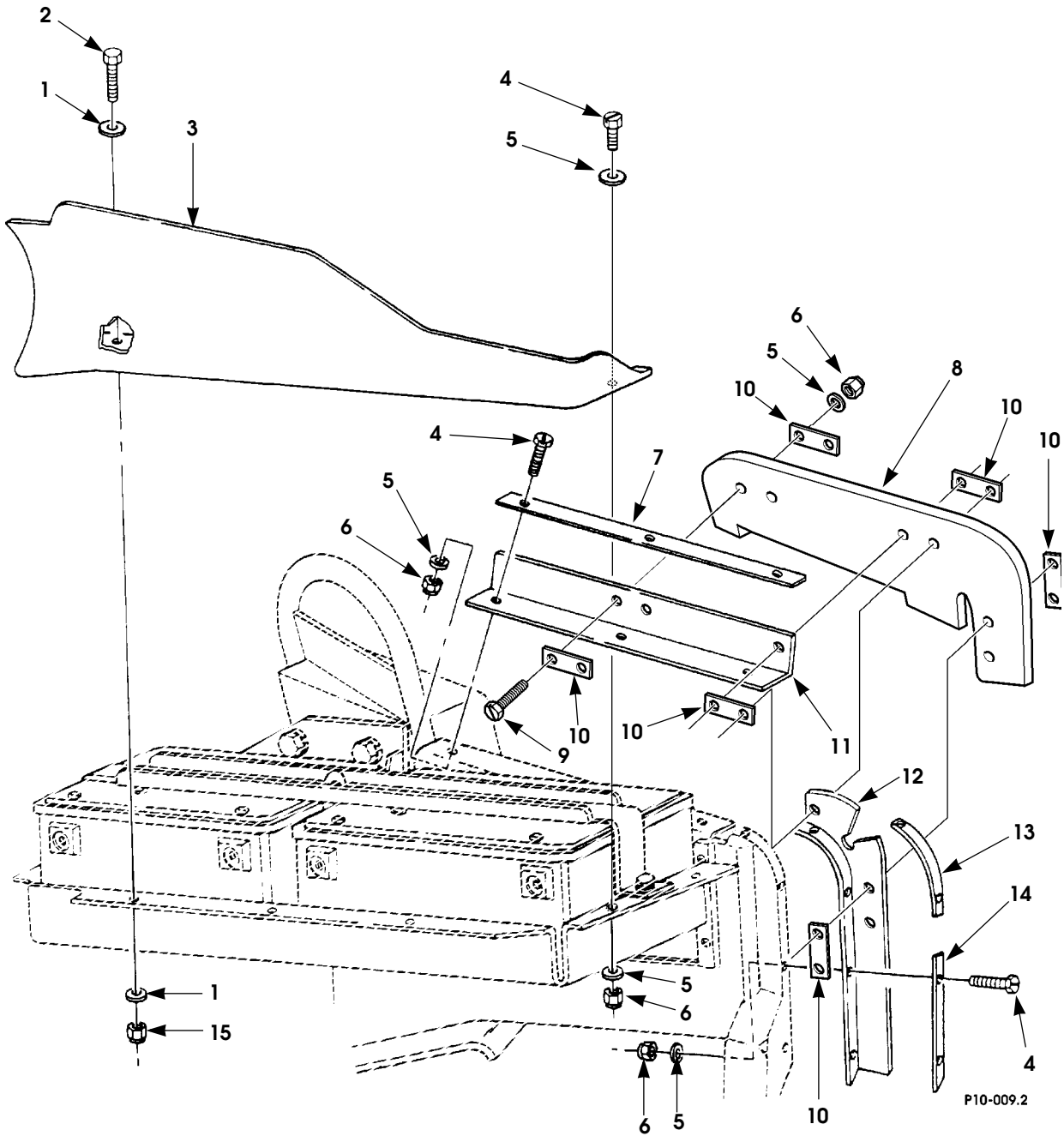

Figure 10-11. Splash Shield (Right Hand Upper) and Seals.

# 2001 HUMMER PARTS CATALOG

**BODY 10-27**

ITEM	PART NUMBER	DESCRIPTION	QTY
		<b>Figure 10-11. Splash Shield (Right Hand Upper) and Seals.</b>	
1	N/S	WASHER, flat, 5/16, CAD . . . . .	3
2	N/S	BOLT, 5/16 - 18 x 1, Gr5, CAD. . . . .	3
3	6007249	SPLASH SHIELD, upper, R.H. . . . .	1
4	N/S	BOLT, #10 - 24 x 3/4, CAD. . . . .	8
5	N/S	WASHER, flat, #10, CAD . . . . .	14
6	N/S	LOCKNUT, #10 - 24, Gr8, CAD . . . . .	14
7	6002924	RETAINER, hood seal, top . . . . .	1
8	6007251	SEAL, shield-to-hood, R.H. . . . .	1
9	N/S	BOLT, #10 - 24 x 1, CAD . . . . .	6
10	12338634 1	RETAINER, splash shield . . . . .	6
11	6002914	SEAL, battery tray-to-hood, top . . . . .	1
12	6002915	SEAL, battery tray-to-hood, front . . . . .	1
13	6002925	RETAINER, hood seal, front . . . . .	1
14	12338634 2P3	RETAINER, seal . . . . .	1
15	N/S	LOCKNUT, 5/16 - 18, Gr8, CAD . . . . .	5

# 2001 HUMMER PARTS CATALOG

## 10-28 BODY

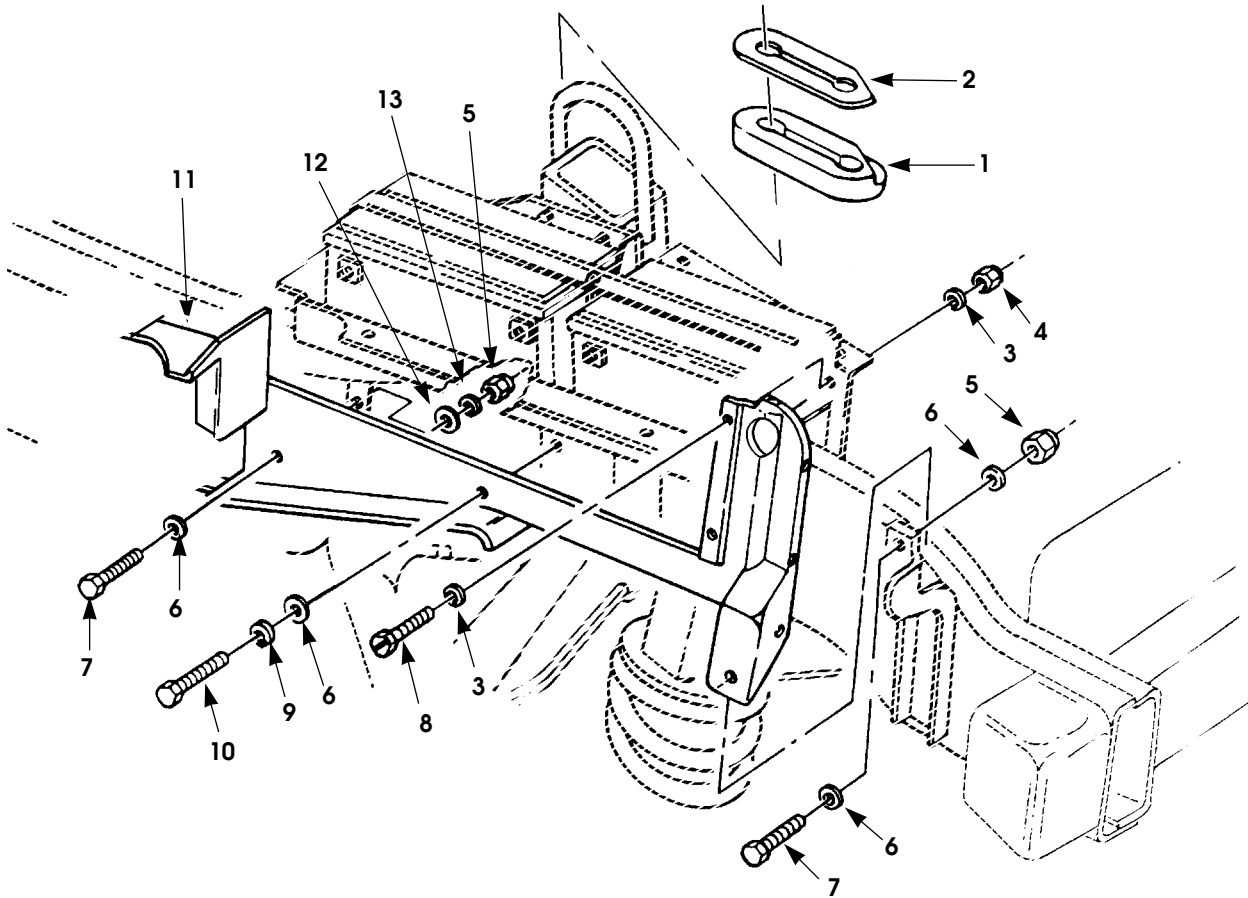

Figure 10-12. Splash Shield, Right Hand Lower.

# 2001 HUMMER PARTS CATALOG

**BODY 10-29**

ITEM	PART NUMBER	DESCRIPTION	QTY
		<b>Figure 10-12. Splash Shield, Right Hand Lower.</b>	
1	12342358	SEAL, airlift bracket, R.H. ....	1
2	6008043	COVER PLATE, airlift bracket seal. ....	1
3	N/S	WASHER, flat, #10, CAD ....	4
4	N/S	LOCKNUT, #10 - 24, Gr8, CAD ....	2
5	N/S	LOCKNUT, 5/16 - 18, Gr8, CAD ....	5
6	N/S	WASHER, flat, 5/16, CAD ....	5
7	N/S	BOLT, 5/16 - 18 x 1, Gr5, CAD. ....	6
8	N/S	SCREW, #10 - 24 x 3/4 ....	2
9	N/S	LOCKWASHER, med, 5/16, ZN ....	1
10	N/S	SCREW, tapping, 5/16 - 18 x 1, type C, ZN ....	1
11	6009388	SPLASH SHIELD, lower, R.H. ....	1
12	9421128	WASHER, flat. ....	1
13	N/S	WASHER, flat, hardened, 5/16, "B", ZN ....	1

# 2001 HUMMER PARTS CATALOG

## 10-30 BODY

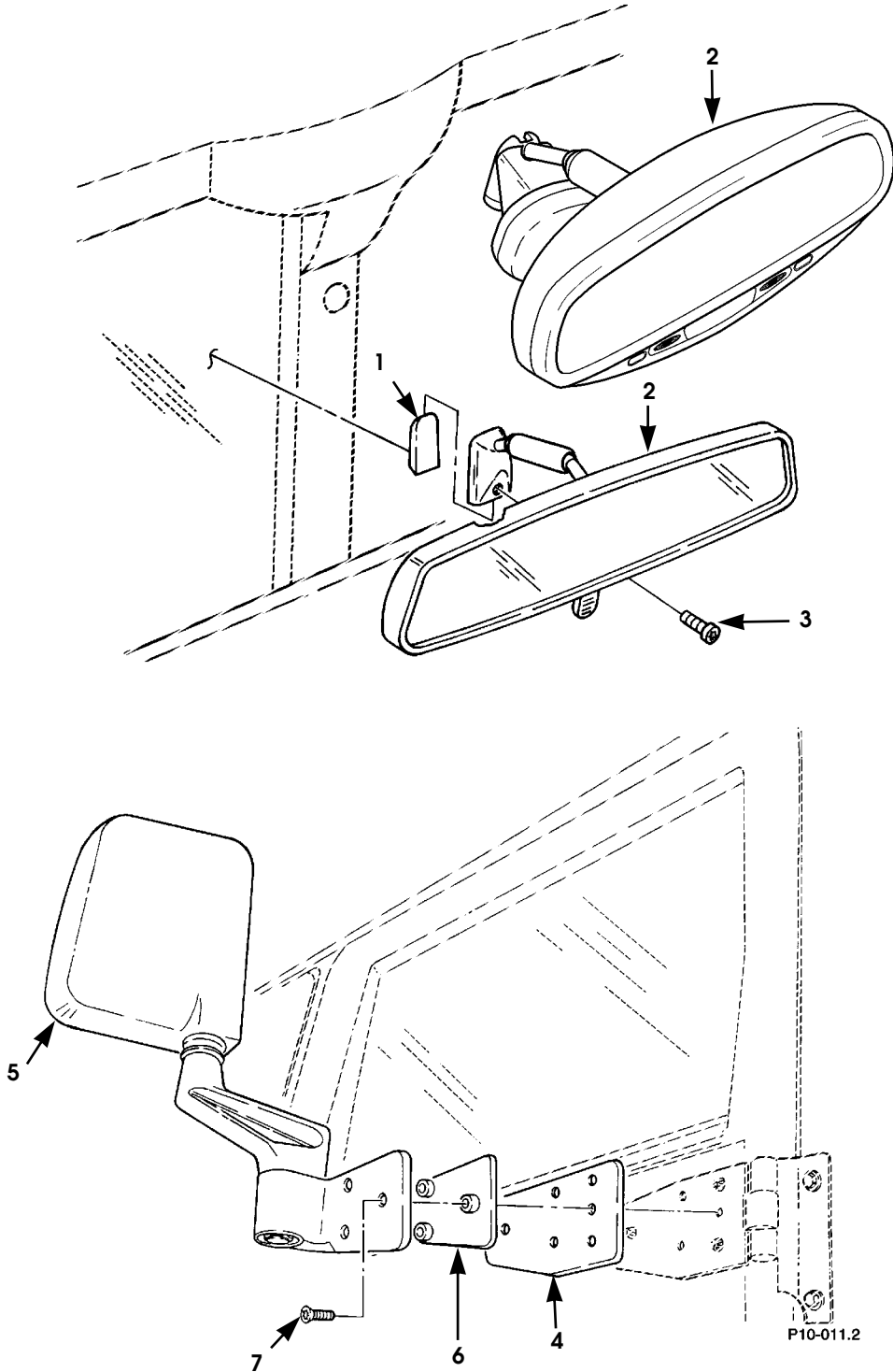

Figure 10-13. Mirrors (Inside and Outside) and Mounting Hardware.

# 2001 HUMMER PARTS CATALOG

**BODY 10-31**

ITEM	PART NUMBER	DESCRIPTION	QTY
		<b>Figure 10-13. Mirrors (Inside and Outside) and Mounting Hardware.</b>	
1	5939643	SUPPORT, inside rearview mirror . . . . .	1
2	5939074	MIRROR ASSEMBLY, rearview, inside, standard . . . . .	1
2	6011323	MIRROR ASSEMBLY, rearview, inside, deluxe, w/compass. . . . .	1
3	S.I.A.	•SCREW, mirror mounting . . . . .	1
4	6003618	PLATE, adapter mirror mounting . . . . .	2
5	5939436	EXTERIOR MIRROR ASSEMBLY, L.H., SEE NOTE 1 . . . . .	1
5	5939393	EXTERIOR MIRROR ASSEMBLY, R.H., SEE NOTE 1 . . . . .	1
6	S.I.A.	•SPACER, exterior mirror . . . . .	1
7	N/S	SCREW, flat head, 1/4 - 20 x 3/4 . . . . .	6
	6007374	HARNESS ASSY, outside temp sensor (not illustrated). . . . .	1
	6011019	SENSOR, outside temperature (not illustrated). . . . .	1
	6011324	HARNESS, rear view mirror (not illustrated) . . . . .	1
		NOTE 1: SEE CHAPTER 12 FOR EXTERIOR HEATED-POWER MIRRORS.	



# 2001 HUMMER PARTS CATALOG

## 10-32 BODY

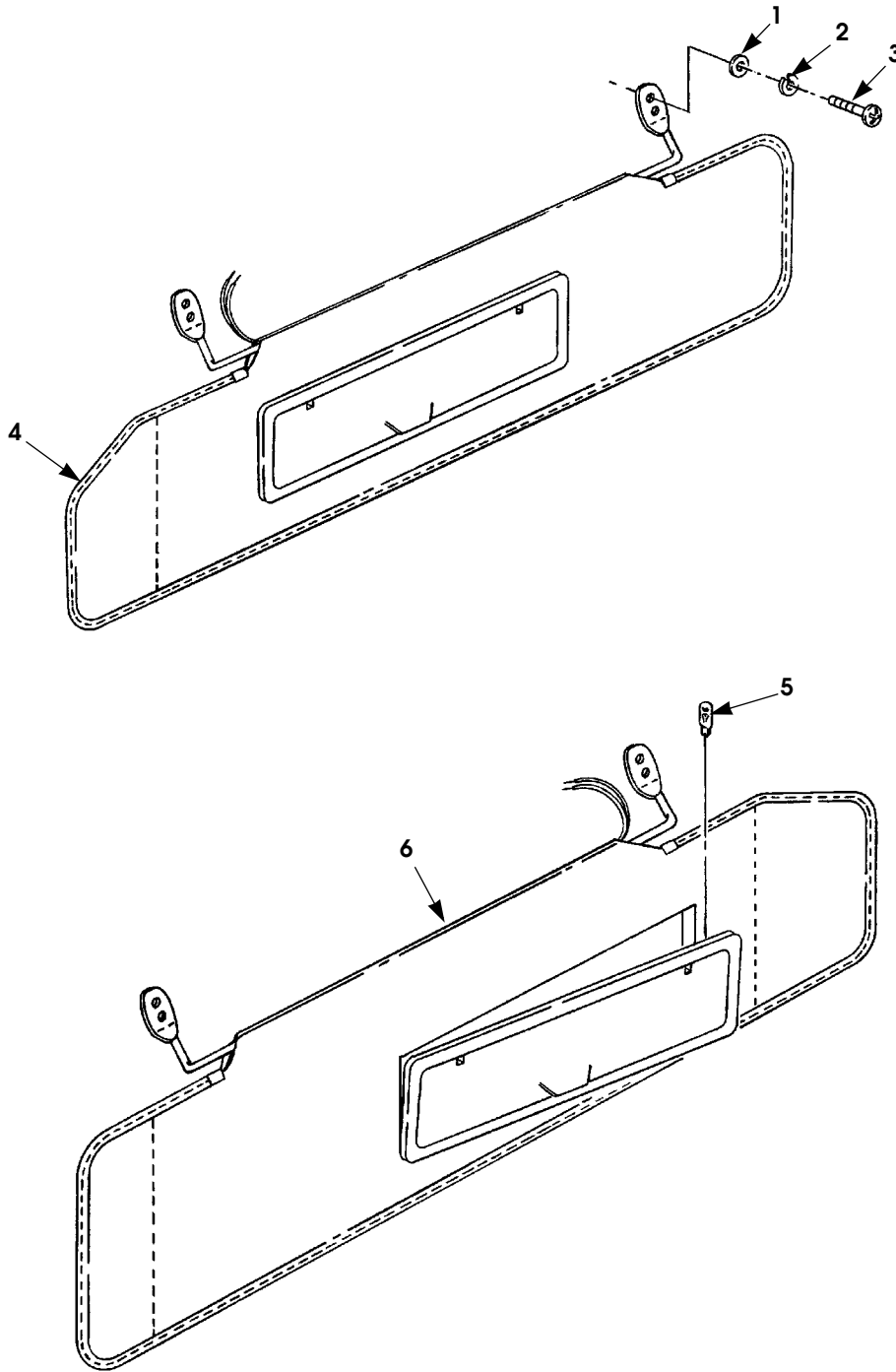

P10-012

Figure 10-14. Sun Visor.

# 2001 HUMMER PARTS CATALOG

**BODY 10-33**

ITEM	PART NUMBER	DESCRIPTION	QTY
		<b>Figure 10-14. Sun Visor.</b>	
.1	N/S	WASHER, flat, #10 . . . . .	8
2	N/S	LOCKWASHER, #10 . . . . .	8
3	N/S	SCREW, pan head, #10 - 24 x 3/4 . . . . .	8
4	6009813G	SUN VISOR, R.H., standard trim, gray . . . . .	1
4	6009813	SUN VISOR, R.H., standard trim, tan . . . . .	1
4	6009815G	SUN VISOR, R.H., deluxe, gray, w/lighted vanity mirror . 83, 84, 89 . . . . .	1
4	6009815	SUN VISOR, R.H., deluxe, tan, w/lighted vanity mirror 83, 84, 89 . . . . .	1
5	N/S	BULB (trade #73) 83, 84, 89 . . . . .	2
6	6009812G	SUN VISOR, L.H., standard trim, gray . . . . .	1
6	6009812	SUN VISOR, L.H., standard trim, tan . . . . .	1
6	6009814G	SUN VISOR, L.H., deluxe, gray, w/lighted vanity mirror . 83, 84, 89 . . . . .	1
6	6009814	SUN VISOR, L.H., deluxe, tan, w/lighted vanity mirror 83, 84, 89 . . . . .	1

# 2001 HUMMER PARTS CATALOG

## 10-34 BODY

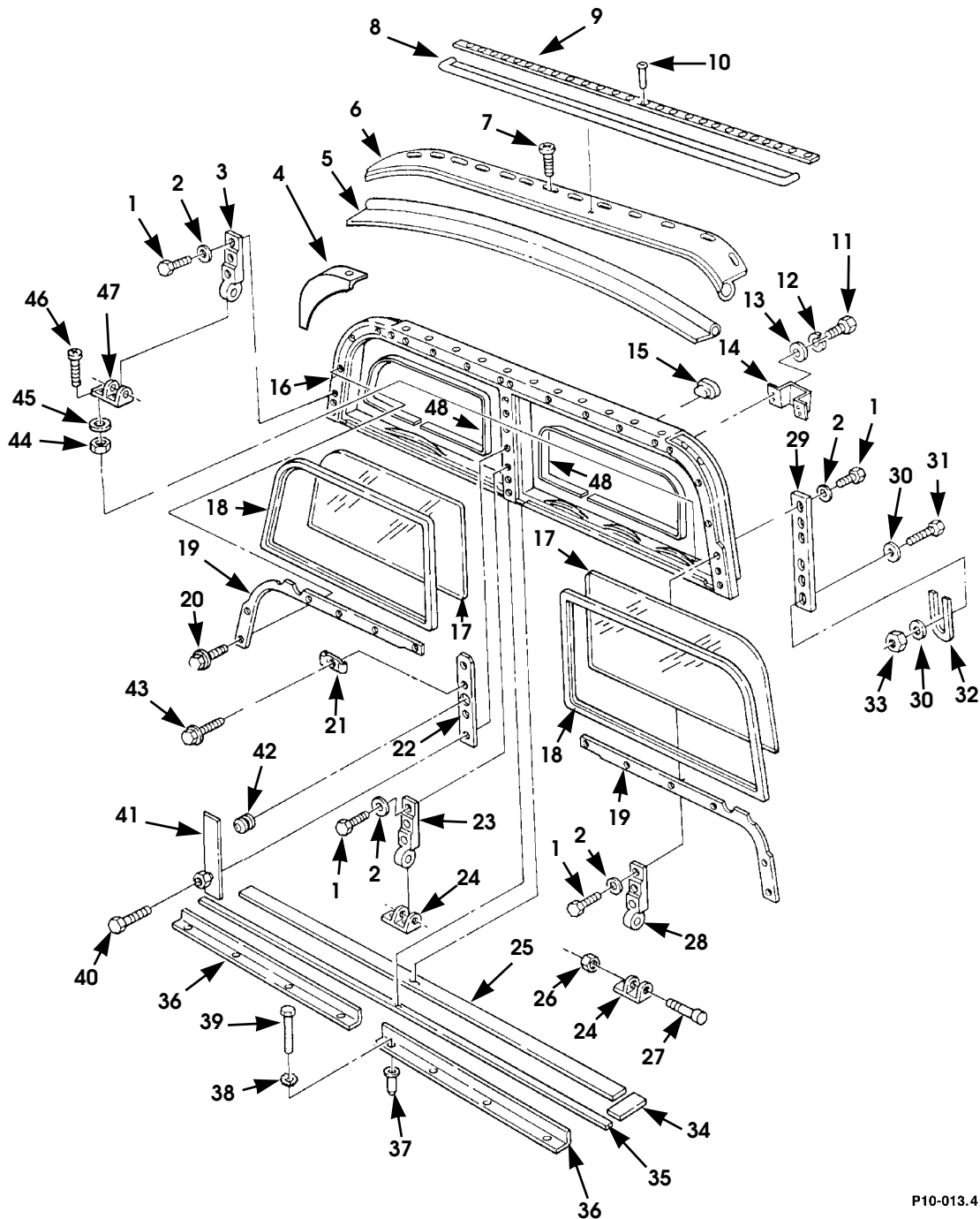

P10-013.4

Figure 10-15. Windshield Assembly.

# 2001 HUMMER PARTS CATALOG

**BODY 10-35**

ITEM	PART NUMBER	DESCRIPTION	QTY
		<b>Figure 10-15. Windshield Assembly.</b>	
1	N/S	BOLT, 5/16 - 18 x 1 1/8, Gr8 . . . . .	15
2	N/S	WASHER, flat, hardened, type B, 5/16 . . . . .	15
3	12338841 2G1	HINGE, R.H. . . . .	1
4	6009700P	CORNER CAP, L.H. . . . . 90	1
4	6009701P	CORNER CAP, R.H. . . . . 90	1
5	6009733	SEAL, windshield frame, upper . . . . . 90	1
6	6009732P	FORMER ASSEMBLY, . . . . . 90	1
7	N/S	SCREW, pan head tapping, #10 - 24 x 1/2 . . . . . 90	11
8	5939991	SEAL . . . . . 83, 84, 89	1
9	12338818P	RETAINER . . . . . 83, 84, 89	1
10	M7885/24 5	RIVET, blind . . . . . 83, 84, 89	27
11	N/S	SCREW, pan head, #10 - 24 x 3/4 . . . . .	16
12	N/S	LOCKWASHER, med, #10, ZN. . . . .	16
13	N/S	WASHER, flat, #10, CAD . . . . .	16
14	6000814B2	BRACKET, visor mounting. . . . .	4
15	12338829	COVER . . . . .	2
16	WD12339513P	FRAME, windshield glass . . . . . 89, 83, 84	1
16	6010223P	FRAME, windshield glass . . . . . 90	1
17	6003519	GLASS, tinted, R.H. . . . .	1
17	6011900	GLASS, heated windshield, R.H., . . . . .	1
17	6008795	GLASS, heated, non-tinted windshield, R.H. (Australia)	1
17	6003520	GLASS, tinted, L.H. . . . .	1
17	6008794	GLASS, heated, non-tinted, windshield, L.H. (Australia)	1
17	6011899	GLASS, heated windshield, L.H., . . . . .	1
18	12338941	WEATHERSTRIP . . . . .	2
19	12338852P	RETAINER, windshield, upper. . . . .	2
20	N/S	SCREW, tapping, #10 - 32 x 5/8. . . . .	12
21	5935689	WIRE RETAINER . . . . .	1

# 2001 HUMMER PARTS CATALOG

## 10-36 BODY

ITEM	PART NUMBER	DESCRIPTION	QTY
		<b>Figure 10-15. Windshield Assembly. (Cont'd)</b>	
22	5935710P	RETAINER, windshield center. . . . .	1
23	12338835	HINGE, middle . . . . .	1
24	12338822 1P	HINGE, lower. . . . .	2
25	6001115	SEAL, 8-foot . . . . .	1
26	N/S	LOCKNUT, 3/8 - 16, Gr8. . . . .	3
27	N/S	BOLT, 3/8 - 16 x 2.00, Gr5 . . . . .	3
28	12338841 1G1	HINGE, L.H. . . . .	1
29	5939340	BRACKET, rear . . . . .	2
30	N/S	WASHER, flat, hard, type B, 5/16 . . . . .	12
31	N/S	BOLT, 5/16 - 18 x 1.25, Gr8 . . . . .	6
32	12338806	SHIM, 2 places . . . . .	A/R
33	N/S	LOCKNUT, 5/16 - 18, Gr8. . . . .	3
34	5939686	SEAL, lower windshield, L.H. . . . .	1
34	5939687	SEAL, lower windshield, R.H. . . . .	1
35	5939685	SEAL. . . . .	1
36	12447029P	RETAINER, windshield, lower . . . . .	2
37	5939334	NUT INSERT, #10 - 24 . . . . .	8
38	N/S	LOCKWASHER, med, #10, ZN . . . . .	8
39	N/S	BOLT, #10 - 24 x 3/4. . . . .	8
40	N/S	SCREW, tapping, #10 - 32 x 7/8. . . . .	2
41	5935687P	COVER ASSEMBLY, wire . . . . .	1
42	5935699	GROMMET, W/S center pillar. . . . .	1
43	5939530P2	SCREW, tapping . . . . .	1
44	N/S	NUT, 5/16 - 18, Gr5 . . . . .	6
45	9424258	LOCKWASHER. . . . .	6
46	N/S	SCREW, fillister head, 5/16 - 18 x 1.25 . . . . .	6
47	12338822 2P	HINGE, lower, R.H. . . . .	1



# 2001 HUMMER PARTS CATALOG

## 10-38 BODY

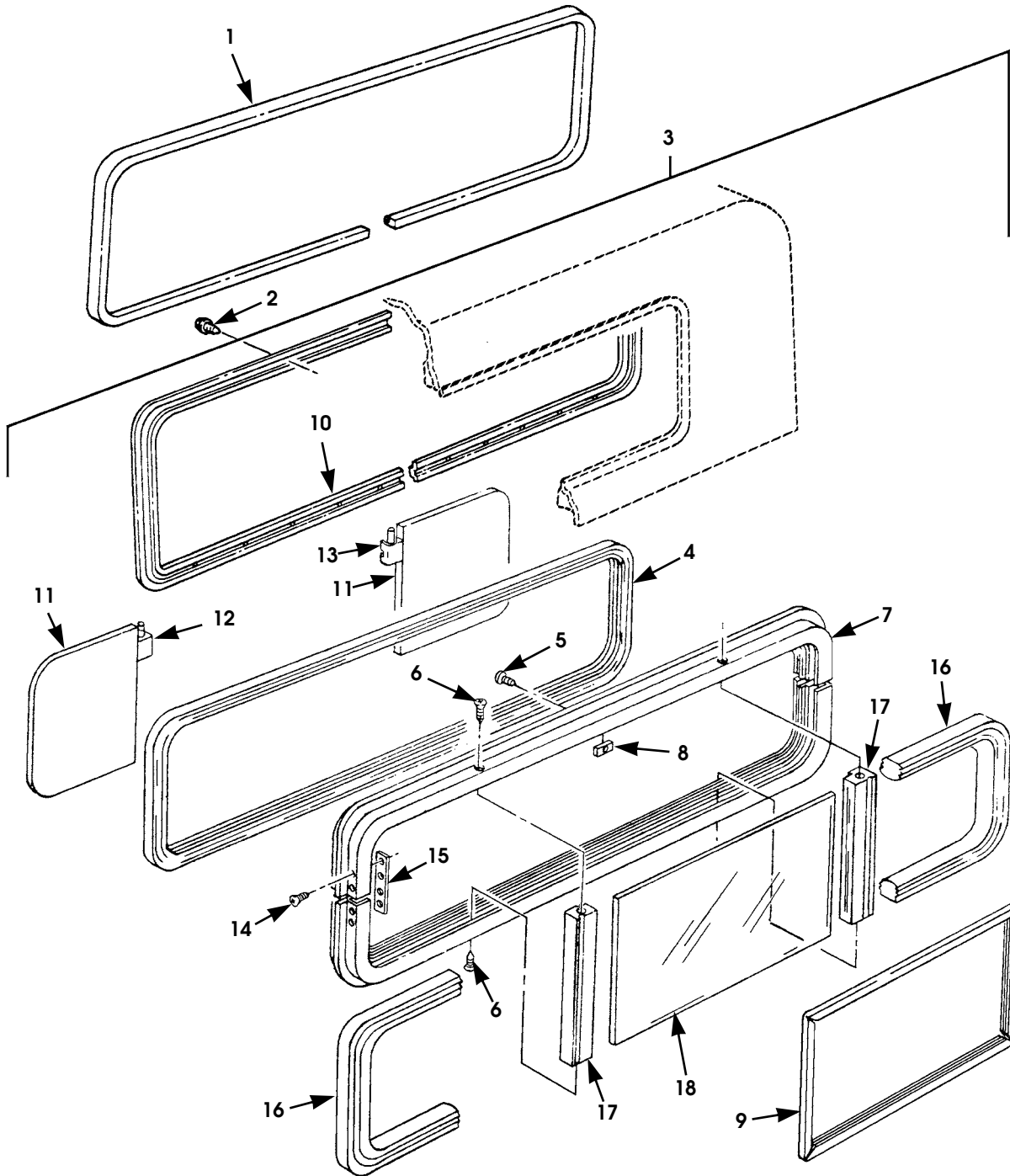

P10-014a

Figure 10-16. Window Assembly, Rear

# 2001 HUMMER PARTS CATALOG

**BODY 10-39**

ITEM	PART NUMBER	DESCRIPTION	QTY
		<b>Figure 10-16. Window Assembly, Rear</b>	
1	5745369	SEAL, inner, rear window, SEE NOTE1 . . . . .	1
2	N/S	SCREW, self tapping, #10-32 . . . . .	24
3	6003517	REAR WINDOW ASSEMBLY, sliding, tinted . . . . .	1
3	6005304	REAR WINDOW ASSEMBLY, sliding, with defroster . . . . .	1
4	S.I.A.	•INNER FRAME . . . . .	1
5	S.I.A.	•SCREW, rear window travel stop . . . . .	2
6	S.I.A.	•SCREW, rear window side post mounting . . . . .	4
7	S.I.A.	•INTERMEDIATE FRAME, rear window . . . . .	1
8	S.I.A.	•TRAVEL STOP, rear window . . . . .	2
9	S.I.A.	•SEAL, outer, rear window . . . . .	1
10	5744496	•CLAMP RING, rear window. . . . .	1
11	S.I.A.	•GLASS, sliding rear window, tinted. . . . .	2
12	5744504	•LOCK, rear window left hand . . . . .	1
13	5744505	•LOCK, rear window right hand . . . . .	1
14	5744500	•SCREW, rear window frame . . . . .	4
15	5744501	•TIE BAR, rear window frame . . . . .	1
16	5744506	•FILLER, window frame 90 inches . . . . .	2
17	5744503	•CENTER POST, rear window . . . . .	2
18	S.I.A.	•GLASS, fixed center section, tinted . . . . .	1
18	S.I.A.	•GLASS, fixed center, w/defroster, tinted . . . . .	1
		NOTE 1: CUT TO 13 FOOT LENGTH FROM 1,000 FOOT BULK SEAL, PN 6000366.	



# 2001 HUMMER PARTS CATALOG

## 10-40 BODY

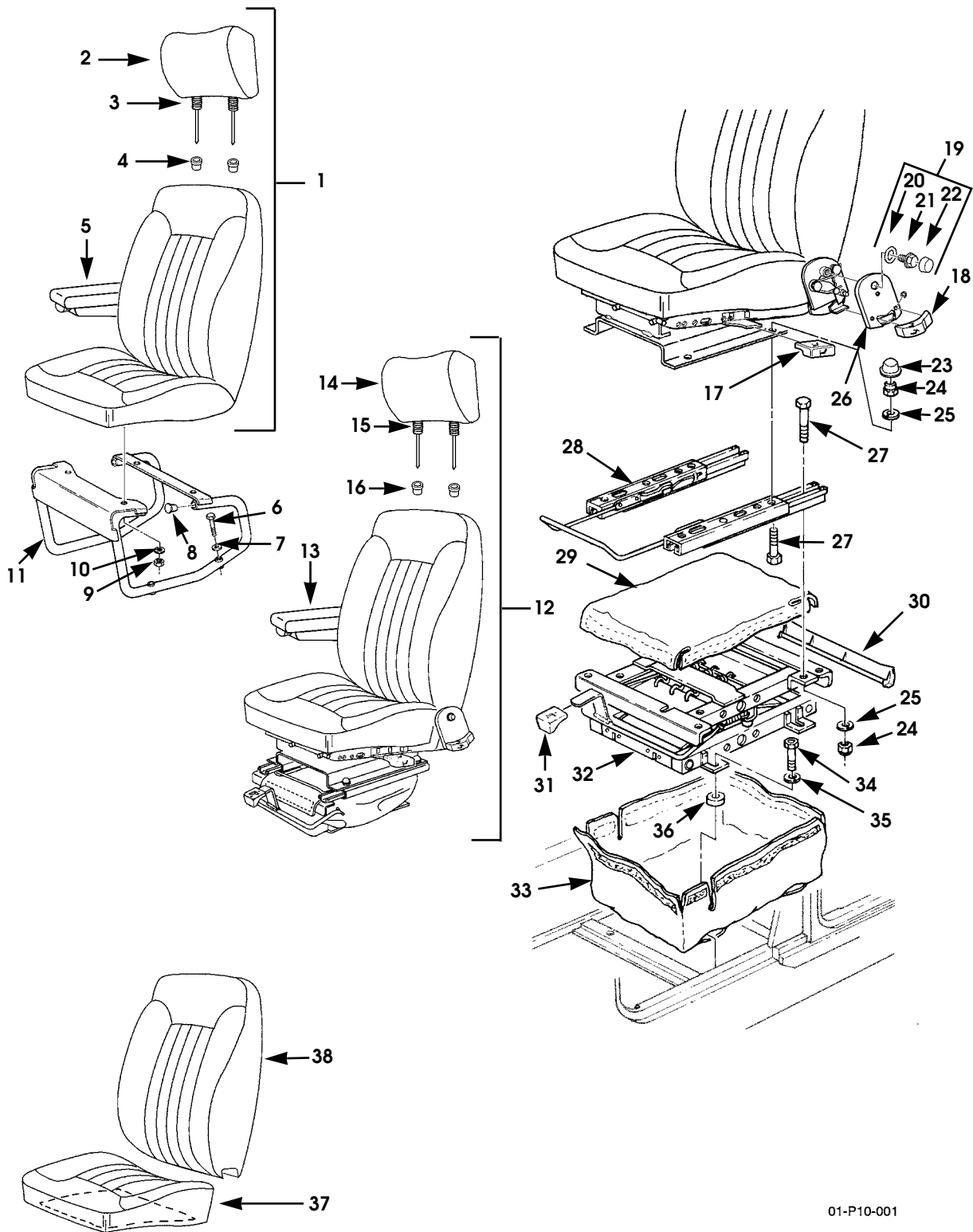

01-P10-001

Figure 10-17. Seats, Driver and Passenger.

# 2001 HUMMER PARTS CATALOG

**BODY 10-41**

ITEM	PART NUMBER	DESCRIPTION	QTY
		<b>Figure 10-17. Seats, Driver and Passenger.</b>	
1	6011396	REAR PASSENGER SEAT ASSEMBLY, w/armrest, LH, black vinyl . . . . .	1
		83, 84, 90, 91	
1	6011397	REAR PASSENGER SEAT ASSEMBLY, w/armrest, RH, black vinyl . . . . .	1
		83, 84, 90, 91	
1	6011644G	REAR PASSENGER SEAT ASSEMBLY, w/armrest, LH, gray 83, 84, 90, 91	1
1	6011645G	REAR PASSENGER SEAT ASSEMBLY, w/armrest, RH, gray 83, 84, 90, 91	1
1	6011644	REAR PASSENGER SEAT ASSEMBLY, w/armrest, LH, tan . 83, 84, 90, 91	1
1	6011645	REAR PASSENGER SEAT ASSEMBLY, w/armrest, RH, tan 83, 84, 90, 91	1
1	6011308	REAR PASSENGER SEAT ASSEMBLY, w/o armrest, black nylon . . . . .	2
		83, 84, 90, 91	
2	5745385	•HEADREST ASSEMBLY, black nylon SEE NOTE 1 . . . . .	1
2	5745225	•HEADREST ASSEMBLY, gray SEE NOTE 1 . . . . .	1
2	5745372	•HEADREST ASSEMBLY, tan SEE NOTE 1 . . . . .	1
2	5744740	•HEADREST ASSEMBLY, black vinyl SEE NOTE 1 . . . . .	1
3	5744839	••BOOT, headrest/seat bar post SEE NOTE 1 . . . . .	2
4	5744826	•FERRULE, headrest post SEE NOTE 1 . . . . .	2
5	5745379	•ARMREST ASSEMBLY, rear, LH, tan . . . . .	1
5	5745380	•ARMREST ASSEMBLY, rear, RH, tan . . . . .	1
5	5745381	•ARMREST ASSEMBLY, rear, LH, gray . . . . .	1
5	5745382	•ARMREST ASSEMBLY, rear, RH, gray . . . . .	1
5	5745383	•ARMREST ASSEMBLY, rear, LH, black vinyl . . . . .	1
5	5745384	•ARMREST ASSEMBLY, rear, RH, black vinyl . . . . .	1
6	N/S	BOLT, 5/16 - 18 x 1.75, Gr5, rear passenger seat support	4
7	N/S	WASHER, flat, hardened, 5/16, rear passenger seat support. . . . .	4
8	12339361 5	PLUG, plastic, rear passenger seat . . . . .	4
9	N/S	LOCKNUT, 5/16 - 18, Gr8, rear passenger seat support. . . . .	4
10	N/S	WASHER, flat, hardened, 5/16, rear passenger seat support. . . . .	4
11	5939508B2	REAR PASSENGER SEAT STANCHION ASSEMBLY . . . . .	1
12	6011306	DRIVER SEAT ASSEMBLY, w/o armrest, black nylon . . . . .	1
12	6011307	PASSENGER SEAT ASSEMBLY, w/o armrest, black nylon	1
12	6011642G	DRIVER SEAT ASSEMBLY, w/armrest, gray . . . . .	1
12	6011643G	PASSENGER SEAT ASSEMBLY, w/armrest, gray . . . . .	1
12	6011642	DRIVER SEAT ASSEMBLY, w/armrest, tan . . . . .	1
12	6011643	PASSENGER SEAT ASSEMBLY, w/armrest, tan . . . . .	1

# 2001 HUMMER PARTS CATALOG

## 10-42 BODY

ITEM	PART NUMBER	DESCRIPTION	QTY
		<b>Figure 10-17.</b> <b>Seats, Driver and Passenger. (Cont'd)</b>	
12	6011813	DRIVER SEAT ASSEMBLY, w/armrest, black vinyl . . . . .	1
12	6011814	PASSENGER SEAT ASSEMBLY, w/armrest, black vinyl . .	1
13	5744743	•ARMREST, driver's, black vinyl . . . . .	1
13	5745227	•ARMREST, driver's, gray . . . . .	1
13	5745373	•ARMREST, driver's, tan . . . . .	1
13	5744746	•ARMREST, passenger's, black vinyl . . . . .	1
13	5745229	•ARMREST, passenger's, gray . . . . .	1
13	5745380	•ARMREST, passenger's, tan . . . . .	1
14	5745225	•HEADREST ASSEMBLY, gray . . . . .	2
14	5745372	•HEADREST ASSEMBLY, tan . . . . .	2
14	5745385	•HEADREST ASSEMBLY, black nylon . . . . .	2
14	5744740	•HEADREST ASSEMBLY, black vinyl . . . . .	2
15	5744839	••BOOT, headrest, seat bar post . . . . .	2
16	5744826	••FERRULE, headrest post . . . . .	2
17	5745418	•KNOB, control, seat tilt, driver's seat . . . . .	1
18	5745419	•KNOB, control, seatback recline, LH . . . . .	1
18	5745420	•KNOB, control, seatback recline, RH . . . . .	1
19	5744877	•KIT, side plate retainer SEE NOTE 2 . . . . .	1
20	S.I.K.	••O-RING . . . . .	2
21	S.I.K.	••BOLT, flanged . . . . .	2
22	S.I.K.	••CAP, plastic . . . . .	2
23	6002698	•PROTECTIVE CAP . . . . .	4
24	N/S	•LOCKNUT, 5/16 - 18, Gr8 . . . . .	8
25	N/S	•WASHER, flat, hardened, type B, 5/16 . . . . .	8
26	5744816	•COVER, side, reclining seat, left, black . . . . .	1
26	5744817	•COVER, side, reclining seat, right, black . . . . .	1
27	N/S	•BOLT, socket head, 5/16 - 18 x 3/4, ZN . . . . .	8
28	12446713	•SLIDE SET, driver seat . . . . .	1
29	5744160	•COVER, height adjuster, black vinyl . . . . .	2
29	5744833	•COVER, height adjuster, gray . . . . .	2
29	5744832	•COVER, height adjuster, tan . . . . .	2
30	5744597	•COVER, frame, black . . . . .	1
31	5744824	•CONTROL KNOB, seat . . . . .	1
32	12446714	•HEIGHT ADJUSTER. . . . .	1
33	5744161	•BAG, height adjuster, black vinyl . . . . .	1
33	5744835	•BAG, height adjuster, gray . . . . .	1
33	5744834	•BAG, height adjuster, tan . . . . .	1
34	N/S	•BOLT, 5/16 - 18 x 3/4, sock . . . . .	8
35	N/S	•LOCKWASHER, med, 5/16, ZN . . . . .	12
36	12343055	•SPACER, seat base . . . . .	4
37	5745387	•UPHOLSTERY, seat, black nylon (cushion not included)	4
37	5745233	•UPHOLSTERY, seat, front, gray (cushion not included)	2
37	5745377	•UPHOLSTERY, seat, front, tan (cushion not included)	2

# 2001 HUMMER PARTS CATALOG

**BODY 10-43**

ITEM	PART NUMBER	DESCRIPTION	QTY
		<b>Figure 10-17. Seats, Driver and Passenger. (Cont'd)</b>	
37	5745237	•UPHOLSTERY, seat, rear, gray (cushion not included)	2
37	5745378	•UPHOLSTERY, seat, rear, tan (cushion not included) .	2
38	5745386	•UPHOLSTERY, seatback, black nylon (no cushion) . . .	2
38	5745231	•UPHOLSTERY, seatback, front, gray (no cushion) . . . .	2
38	5745375	•UPHOLSTERY, seatback, front, tan (no cushion) . . . . .	2
38	5745235	•UPHOLSTERY, seatback, rear, gray (no cushion) . . . . .	2
38	5745376	•UPHOLSTERY, seatback, rear, tan (no cushion) . . . . .	2
	5744690	•RECLINER MECHANISM, driver's seat (not illustrated)	1
	5744800	•CLIP, upholstery retaining (not illustrated). . . . .	v
		 NOTE 1: ALSO USED ON DRIVER'S AND FRONT PASSENGER SEATS.	
		 NOTE 2: KIT INCLUDES TWO OF EACH COMPONENT TO SERVICE THE OUTER SIDE OF BOTH THE DRIVER'S AND FRONT PASSENGER SEATS.	

# 2001 HUMMER PARTS CATALOG

## 10-44 BODY

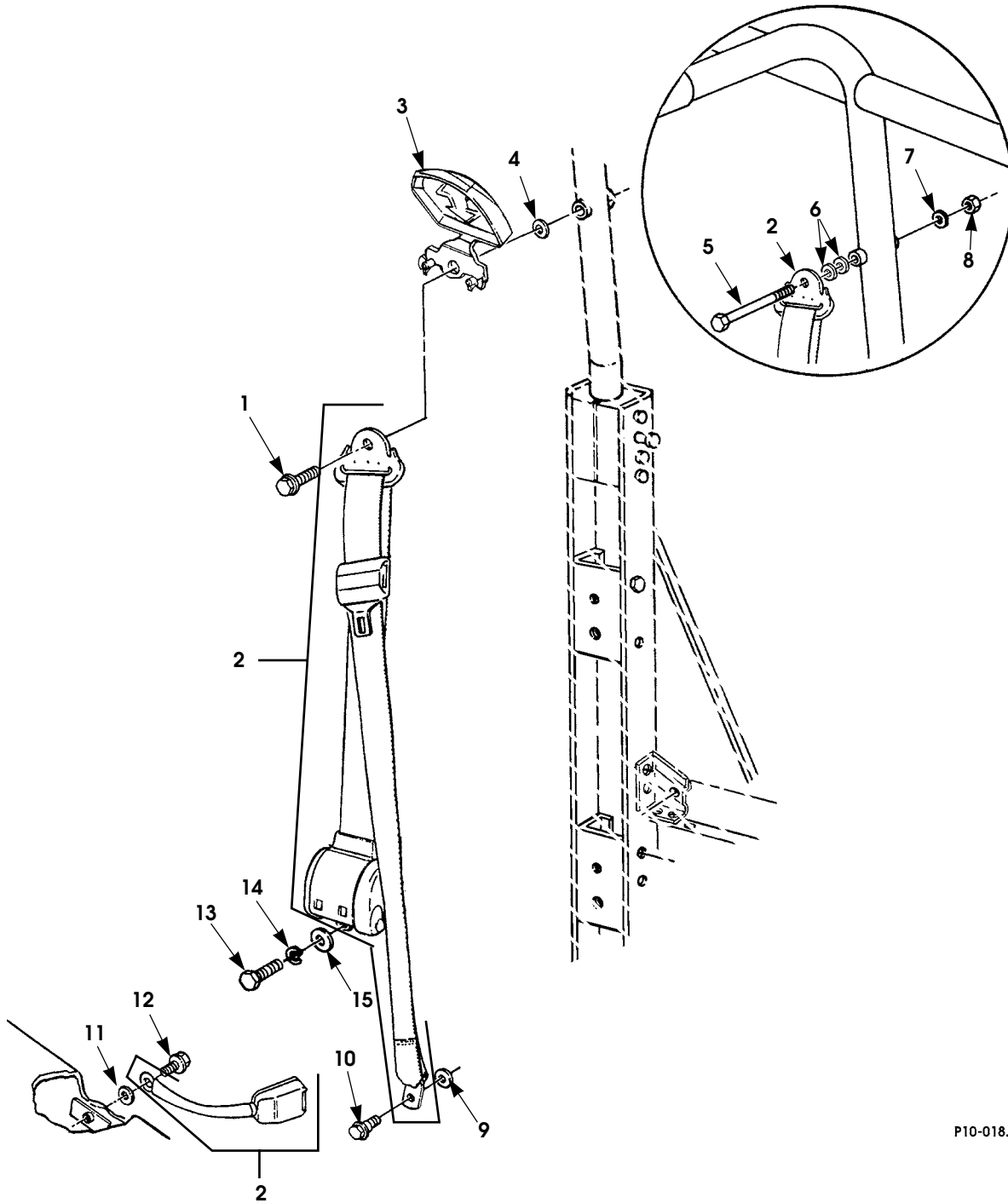

P10-018.1

Figure 10-18. Seat Belts, Front and Rear.

# 2001 HUMMER PARTS CATALOG

**BODY 10-45**

ITEM	PART NUMBER	DESCRIPTION	QTY
		<b>Figure 10-18. Seat Belts, Front and Rear.</b>	
1	6004980P2	BOLT, front seat belt anchor . . . . . 89	2
1	6004162P2	BOLT, seat belt anchor . . . . . 83, 84, 90	2
2	5743857	KIT, front seat belt, L.H. . . . .	1
2	5743858	KIT, front seat belt, R.H. . . . .	1
2	5743860	KIT, rear seat belt . . . . .	2
3	6004161	•COVER, webbing guide . . . . . 89	2
3	6004161	•COVER, webbing guide . . . . . 83, 84	4
4	N/S	WASHER, flat, hardened, type B, 7/16 . . . . . 89	2
4	12341856P2	WASHER . . . . . 83, 84	4
5	12340259 4P2	BOLT, front seat belt . . . . . 90	2
5	N/S	BOLT, 7/16 - 20 x 1 1/4, rear seat belt . . . . . 90	2
6	N/S	WASHER, flat, hardened, type B, 7/16, front and rear seat belt . . . . . 90	8
7	N/S	WASHER, flat, hardened, type B, 7/16, front seat belt . 90	2
8	N/S	LOCKNUT, 7/16 - 20, Gr8, CAD, front seat belt. . . . . 90	2
9	12340058P2	WASHER, hardened . . . . . 89, 90	2
9	12340058P2	WASHER . . . . . 83, 84	4
10	12340259 6P2	BOLT . . . . . 89, 90	2
10	12340259 6P2	BOLT . . . . . 83, 84	4
11	12340058P2	WASHER, hardened . . . . . 89, 90	2
11	12340058P2	WASHER . . . . . 83, 84	8
12	12340259 3P2	BOLT . . . . . 89, 90	2
12	12340259 3P2	BOLT . . . . . 83, 84	4

# 2001 HUMMER PARTS CATALOG

## 10-46 BODY

ITEM	PART NUMBER	DESCRIPTION	QTY
		<b>Figure 10-18. Seat Belts, Front and Rear. (Cont'd)</b>	
13	453719P2	BOLT..... 89	2
13	N/S	BOLT, 7/16 - 20 x 1.0, Gr8, rear seat belt..... 83, 84	2
14	N/S	LOCKWASHER, med, 7/16, ZN, rear seat belt..... 83, 84	2
15	N/S	WASHER, hardened, type B, 7/16..... 89, 90	2
15	N/S	WASHER, hardened, type B, 7/16..... 83, 84	4





# 2001 HUMMER PARTS CATALOG

## 10-48 BODY

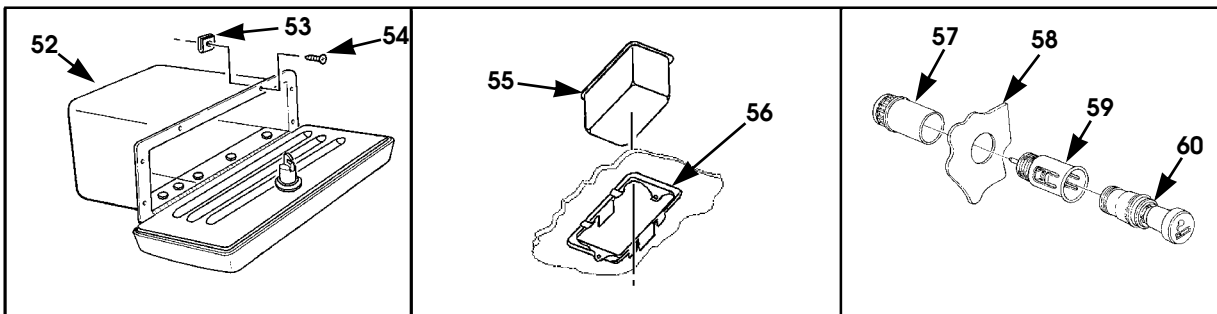
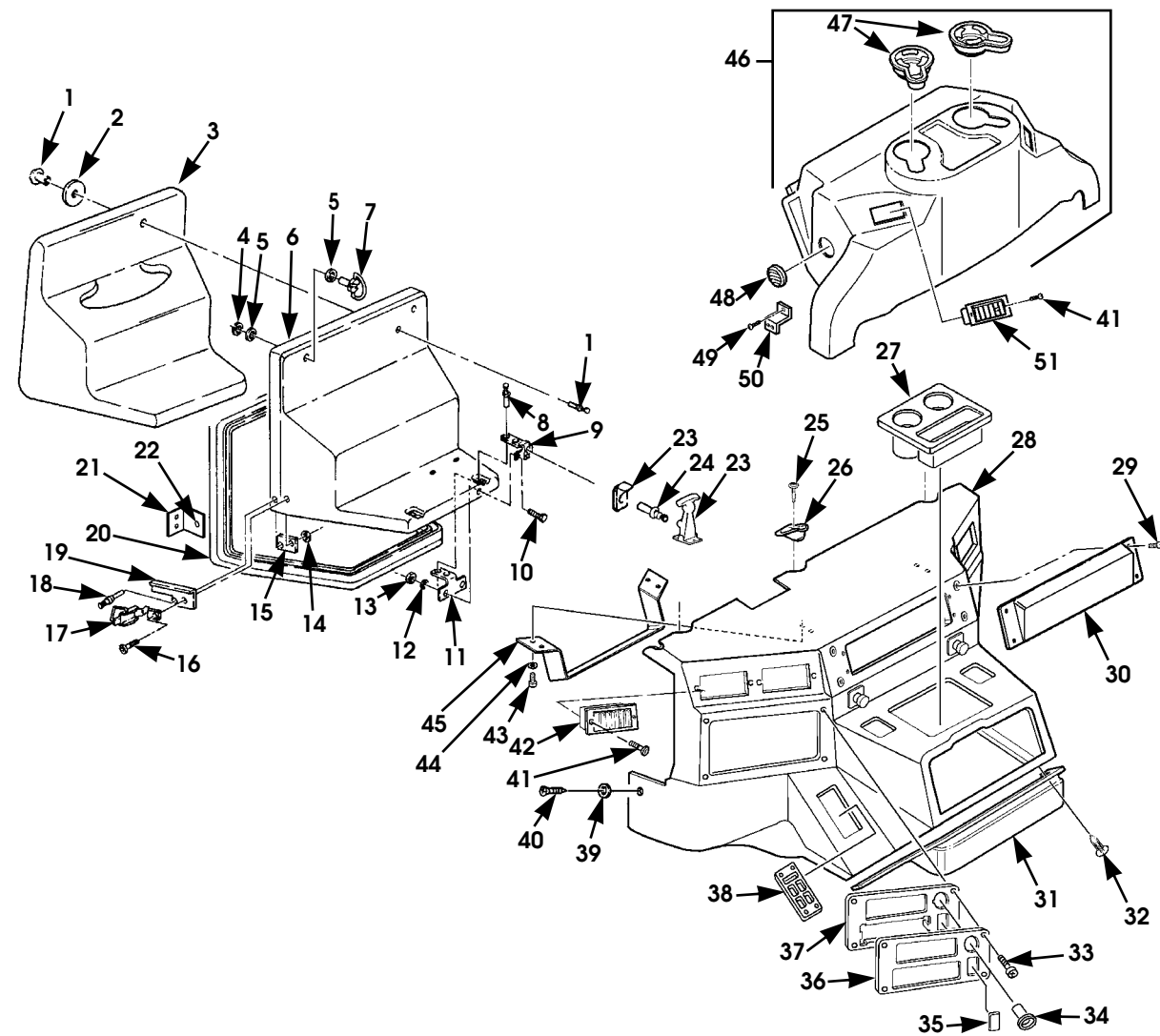

00-P10-003.1

Figure 10-19. Engine Cover, Console Cover, and Related Parts.

# 2001 HUMMER PARTS CATALOG

**BODY 10-49**

ITEM	PART NUMBER	DESCRIPTION	QTY
		<b>Figure 10-19. Engine Cover, Console Cover, and Related Parts.</b>	
1	12339737	RIVET ASSEMBLY, 2-piece, 3/16, aluminum (part number includes one of each piece) . . . . .	6
2	12341718	WASHER, engine cover insulation, snapping . . . . .	6
3	6006786	INSULATION, engine cover . . . . .	1
4	12341011	RING, retaining. . . . .	2
5	N/S	WASHER, flat, hardened, 7/16, type B . . . . .	2
6	6010078	ENGINE COVER . . . . .	1
7	12339738 1	STUD, ring head . . . . .	2
8	M7885/26 4	RIVET . . . . .	4
9	RCSK1741 3	BRACKET, engine cover hold-down, rear . . . . .	2
10	N/S	SCREW, hex head, #10 - 24 x 5/8 . . . . .	4
11	RCSK1763 9	PLATE, engine cover hold-down bracket, rear. . . . .	2
12	N/S	WASHER, narrow, type B, #10, ZN. . . . .	8
13	N/S	NUT, #10 - 24, CAD . . . . .	4
14	N/S	LOCKNUT, pt, 5/16 - 18. . . . .	2
15	12338943	PLATE, latch backing, front . . . . .	2
16	12339428	BOLT, shoulder . . . . .	2
17	12338950	LATCH ASSEMBLY, engine cover hold-down, front . . . . .	2
18	M7885/36 4	RIVET, countersunk. . . . .	2
19	12338952 1	GUIDE PLATE, engine cover, front, L.H. . . . .	1
19	12338952 2	GUIDE PLATE, engine cover, front, R.H. . . . .	1
20	RCSK1779 6	SEAL, engine cover . . . . .	1
21	5939910	MOUNTING BRACKET, engine cover console . . . . .	1
22	5937810	NUT INSERT, 1/4 - 20 . . . . .	1
23	12338946	LATCH AND KEEPER (part number includes two of each piece). . . . .	1
24	N/S	RIVET, blind, aluminum, 1/8, grip .063 - .125. . . . .	4
25	6002686G	TRIM SCREW, 3/4, gray . . . . .	3
25	6002686	TRIM SCRW, 3/4, tan . . . . .	3
26	6010765G	GROMMET, trim, mounting, gray . . . . .	3
26	6010765	GROMMET, trim, mounting, tan . . . . .	3
27	6008031	CUP HOLDER . . . . .	1
28	6010799	FRONT CONSOLE ASSEMBLY, tan . . . . .	1
28	6010799G	FRONT CONSOLE ASSEMBLY, gray . . . . .	1
29	N/S	SCREW, oval head, #10 - 32 x 3/4. . . . .	1
30	6009428	COVER, CD changer opening (when no changer is installed) . . . . .	1
31	6011119	CLOSEOUT PANEL, front console, rear . . . . .	1
32	6001038	TRIM BUTTON, tan. . . . .	4
32	6001038G	TRIM BUTTON, gray. . . . .	4

# 2001 HUMMER PARTS CATALOG

## 10-50 BODY

ITEM	PART NUMBER	DESCRIPTION	QTY
		<b>Figure 10-19. Engine Cover, Console Cover, and Related Parts. (Cont'd)</b>	
33	5939651P2	SCREW.....	14
34	6007236	POWER POINT.....	1
35	6005533	PANEL, blank.....	1
36	6007462	BEZEL, HVAC controller, w/o radio.....	1
36	6009463	BEZEL, HVAC controller, w/radio.....	1
37	6009106B9	RETAINER, HVAC controller/radio.....	1
38	6008727	PLATE, power window switches only.....	1
		89	
38	6011331	PLATE, power windows, heated windshield switches. 89	1
38	6008729	PLATE, power windows switches only.....	1
		83, 84, 90	
38	6011332	PLATE, power windows, heated windshield switches. 83, 84, 90	1
38	6011333	PLATE, heated windshield switch only.....	1
		89	
38	6008742	PLATE, closeout, no switches.....	1
		89	
39	121641P2	WASHER.....	2
40	N/S	SCREW, oval head, 1/4 - 20 x 3/4.....	2
41	N/S	SCREW, #6 - 32 x 3/4, (two per louver).....	10
42	5744793	LOUVER, rectangular, w/o adapter, SEE NOTE 1....	3
43	N/S	SCREW, phcr, #10 - 32 x 3/4.....	4
44	N/S	WASHER, flat, #10, bracket, CD changer.....	4
45	6010786	BRACKET, CD changer, front.....	1
46	6010973G	REAR CONSOLE ASSEMBLY, standard, gray.....	1
46	6010973	REAR CONSOLE ASSEMBLY, standard, tan.....	1
46	6011049G	REAR CONSOLE ASSEMBLY, with rear seat audio, gray.....	1
46	6011049	REAR CONSOLE ASSEMBLY, with rear seat audio, tan.....	1
47	6010976	●CUP HOLDER ASSEMBLY, rear.....	2
48	5743504	LOUVER, circular, side vent.....	3
49	N/S	TRIM SCREW, #8 - 18 x 1.....	
50	6004817B9	SUPPORT, rear console.....	1
51	5744793	LOUVER, rectangular, w/o adapter.....	2
52	6007061	GLOVEBOX.....	1
53	6001894	J-NUT.....	14
54	N/S	SCREW, #10 - 16 x 3/4.....	14
55	6007110	ASHTRAY.....	2

# 2001 HUMMER PARTS CATALOG

**BODY 10-51**

ITEM	PART NUMBER	DESCRIPTION	QTY
		<b>Figure 10-19.</b> <b>Engine Cover, Console Cover, and Related Parts.</b> <b>(Cont'd)</b>	
56	S.I.A.	•MOUNTING BRACKET, ashtray .....	2
57	5939557	CLAMP, shell, lighter .....	2
58	6001208	BEZEL, lighter .....	2
59	5939559	SOCKET, CIGAR LIGHTER .....	2
60	5939897	CIGAR LIGHTER, knob and element .....	2
		NOTE 1: PART OF DASH KIT, P/N 6009548	

# 2001 HUMMER PARTS CATALOG

## 10-52 BODY

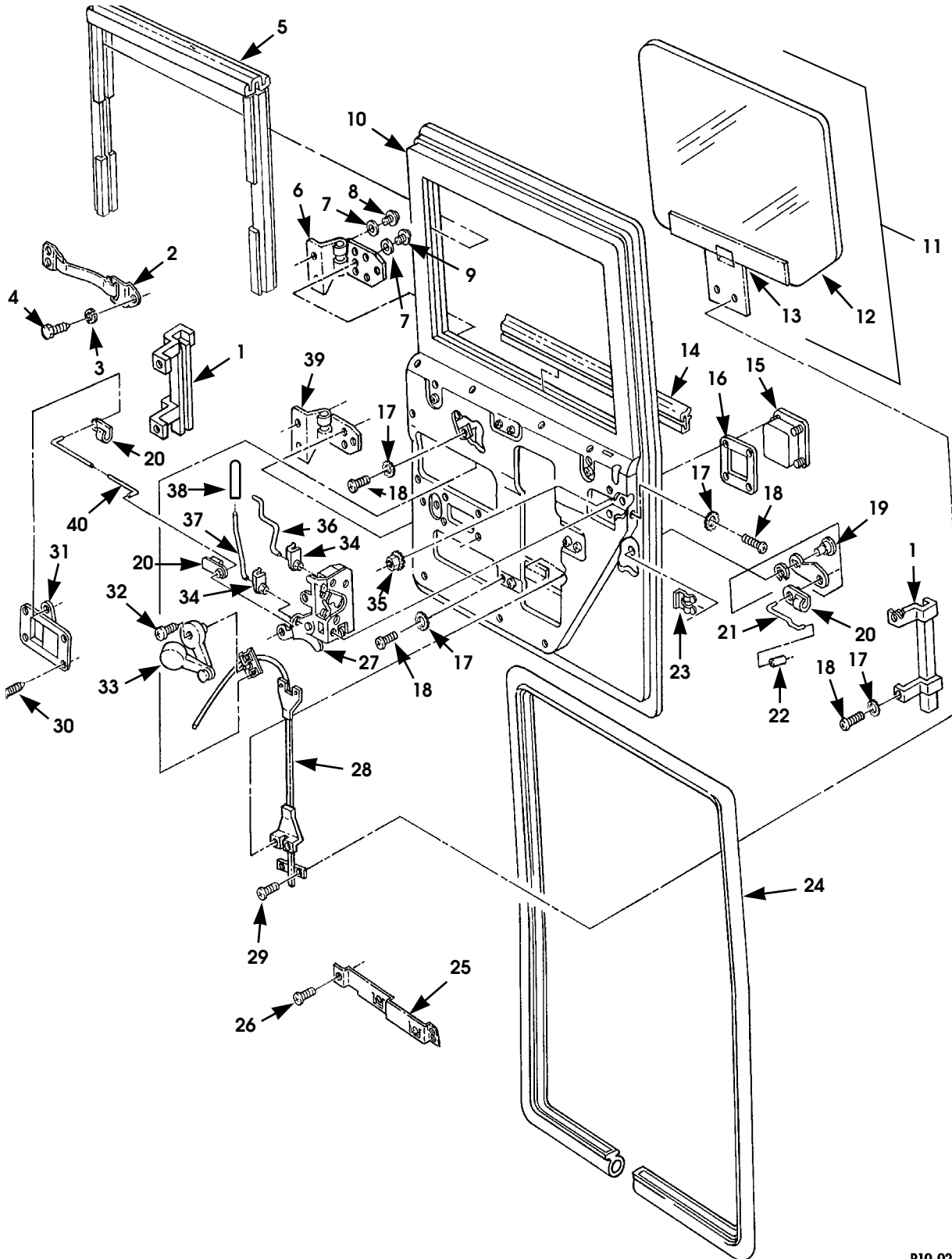

Figure 10-20. Door Assembly, Front.

P10-02C

# 2001 HUMMER PARTS CATALOG

**BODY 10-53**

ITEM	PART NUMBER	DESCRIPTION	QTY
		<b>Figure 10-20. Door Assembly, Front.</b>	
1	5938919	CHANNEL ASSEMBLY, front door glass, lower front, L.H.	1
1	5938920	CHANNEL ASSEMBLY, front door glass, lower front, R.H.	1
1	6000056	CHANNEL ASSEMBLY, front door glass, lower rear, L.H. .	1
1	6000057	CHANNEL ASSEMBLY, front door glass, lower rear, R.H..	1
2	6004975	STRAP ASSEMBLY, door stop, front. . . . .	1
3	N/S	WASHER, flat, hardened, type B, 1/4 . . . . .	1
4	N/S	BOLT, 1/4 - 20 x 1.0, Gr8, CAD . . . . .	4
5	6008389	SEAL, side door window . . . . .	1
6	6003620P	DOOR HINGE ASSEMBLY, upper front, L.H. . . . .	1
6	6003621P	DOOR HINGE ASSEMBLY, upper front, R.H. . . . .	1
7	5939634P2	WASHER, hinge mounting . . . . .	12
8	5939223P2	BOLT, hinge, upper. . . . .	3
9	5939423P2	BOLT, hinge, lower . . . . .	3
10	6003642P	DOOR ASSEMBLY, front, L.H. . . . .	1
10	6003641P	DOOR ASSEMBLY, front, R.H. . . . .	1
11	5744554	GLASS AND LIFT CHANNEL, tinted glass, L.H., front. . . .	1
12	6003516	•GLASS, tinted . . . . .	1
13	6001887	•LIFT CHANNEL . . . . .	1
11	5744555	GLASS AND LIFT CHANNEL, tinted glass, R.H., front. . . .	1
12	6003516	•GLASS, tinted . . . . .	1
13	6001887	•LIFT CHANNEL . . . . .	1
14	6011776	SEAL, belt line . . . . .	2
15	6002874	HANDLE ASSEMBLY, exterior door, front . . . . .	1
16	6000248	GASKET, exterior door handle . . . . .	1
17	N/S	LOCKWASHER, external tooth, 1/4. . . . .	13
18	N/S	SCREW, phcr, M6 - 1.0 x 13 . . . . .	13
19	N/S	LOCK CYLINDER, L.H., SEE NOTE 1 . . . . .	1
19	N/S	LOCK CYLINDER, R.H., SEE NOTE 1 . . . . .	1
20	5939037	CLIP, rod end . . . . .	3
21	5938964	ROD, key cylinder to latch, L.H. . . . .	1
21	5939714	ROD, key cylinder to latch, R.H. . . . .	1
22	6002905	SLEEVE, latch rod . . . . .	1
23	5939371	CLIP, key cylinder, retaining. . . . .	1
24	6006447	SEAL, door, black foam, 120 inches long. . . . .	1
25	6004422	BRACKET ASSEMBLY, front door, arm rest mounting, L.H.	1
25	6004434	BRACKET ASSEMBLY, front door, arm rest mounting, R.H.	1
26	N/S	SCREW, ph, 1/4 - 20 x 1 3/4 . . . . .	1

# 2001 HUMMER PARTS CATALOG

## 10-54 BODY

ITEM	PART NUMBER	DESCRIPTION	QTY
		<b>Figure 10-20. Door Assembly, Front. (Cont'd)</b>	
27	5938960	LATCH ASSEMBLY, L.H. . . . .	1
27	5938961	LATCH ASSEMBLY, R.H. . . . .	1
28	5938949	WINDOW REGULATOR ASSEMBLY, L.H. . . . .	1
28	5938950	WINDOW REGULATOR ASSEMBLY, R.H. . . . .	1
28	6002870	POWER REGULATOR, L.H. . . . .	1
28	6002871	POWER REGULATOR, R.H. . . . .	1
29	N/S	SCREW, torx head, M6 - 1 x 11. . . . .	2
30	9425422P2	SCREW, tapping . . . . .	4
31	6000249	HANDLE ASSEMBLY, door interior, L.H. . . . .	1
31	6000250	HANDLE ASSEMBLY, door interior, R.H. . . . .	1
32	N/S	SCREW, flat head, 10 - 24 x 1, window crank. . . . .	1
33	5938951	HANDLE, window regulator. . . . .	1
34	12340002	CLIP, rod, handle end, R.H. . . . .	2
34	12340003	CLIP, rod, handle end, L.H. . . . .	2
35	N/S	NUT AND LOCKWASHER, keps #10 - 24 . . . . .	4
36	6011276	ROD, exterior handle to latch, front. . . . .	2
37	5938965	ROD, lock pin to latch, L.H. . . . .	1
37	5938966	ROD, lock pin to latch, R.H. . . . .	1
38	6009112	KNOB, door lock. . . . .	1
39	5938962P	DOOR HINGE ASSEMBLY, lower, L.H. . . . .	1
39	5938963P	DOOR HINGE ASSEMBLY, lower, R.H. . . . .	1
40	6000064	ROD, interior handle to latch, front . . . . .	1
	5744322	SEAL, body, 50 foot roll (not illustrated) . . . . .	1
	6001623	WATERSHIELD, L.H., front door (not illustrated). . . . .	1
	6001624	WATERSHIELD, R.H., front door (not illustrated) . . . . .	1
	6011830	SPRING, door latch (not illustrated) . . . . .	1
	6011277	COUPLING, door latch (not illustrated) . . . . .	1
		 NOTE 1: ORDER LOCK CYLINDER KIT P/N 6001766	





# 2001 HUMMER PARTS CATALOG

## 10-56 BODY

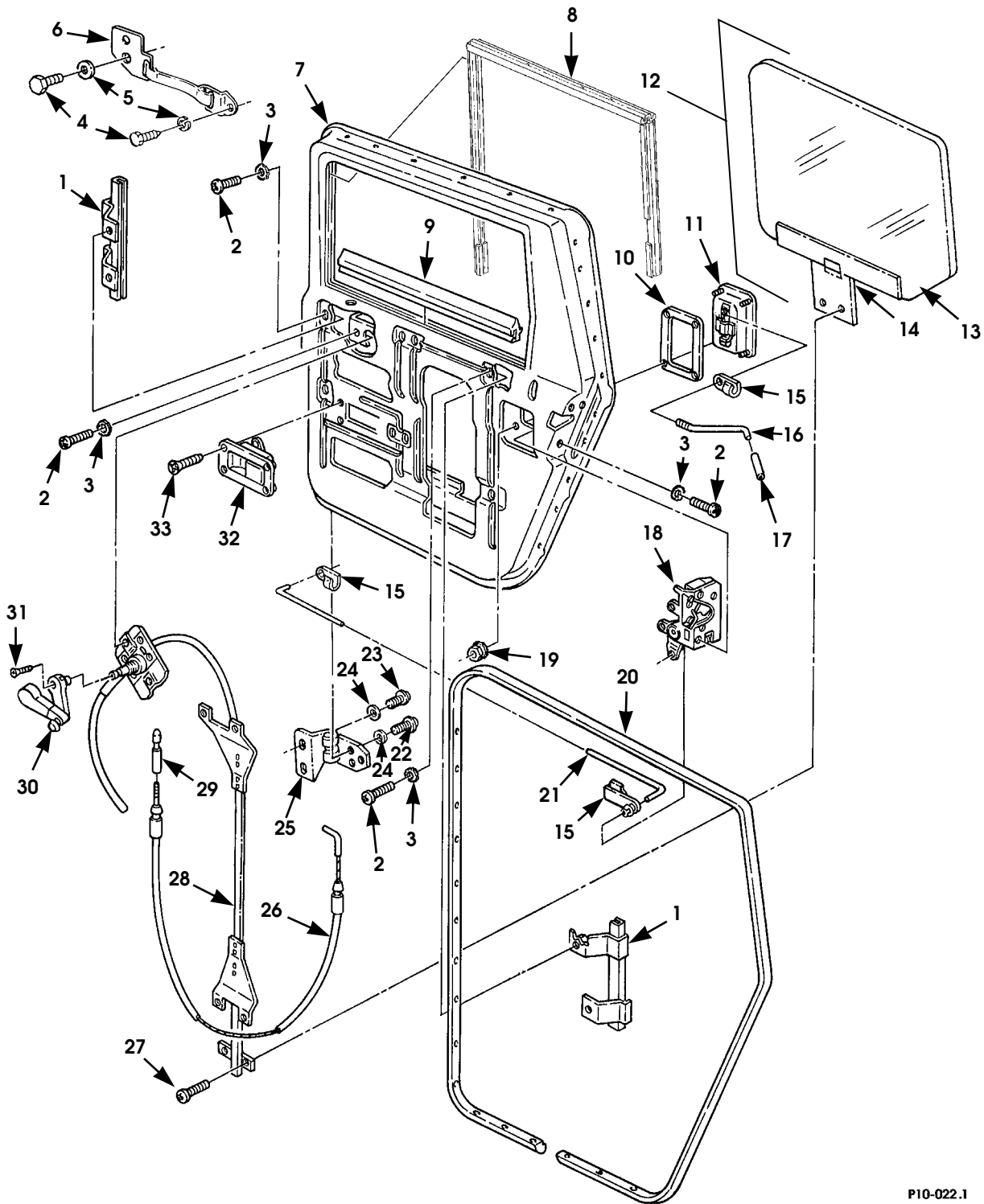

P10-022.1

Figure 10-21. Door Assembly, Rear,  
Models 83, 84, and 90.

# 2001 HUMMER PARTS CATALOG

**BODY 10-57**

ITEM	PART NUMBER	DESCRIPTION	QTY
		<b>Figure 10-21. Door Assembly, Rear, Models 83, 84, and 90.</b>	
1	5938921	CHANNEL ASSEMBLY, front door glass, lower rear, L.H. .	1
1	5938922	CHANNEL ASSEMBLY, front door glass, lower rear, R.H..	1
1	6000058	CHANNEL ASSEMBLY, rear door glass, lower rear, L.H. .	1
1	6000087	CHANNEL ASSEMBLY, rear door glass, lower rear, R.H. .	1
2	N/S	SCREW, ph, M6-1.0 x 13 . . . . .	10
3	N/S	LOCKWASHER, ext tooth, 1/4 . . . . .	13
4	N/S	BOLT, 1/4 - 20 x 1.0, Gr8, CAD . . . . .	4
5	N/S	WASHER, flat, hardened, type B, 1/4 . . . . .	4
6	6004971	STRAP ASSEMBLY, door stop, rear, L.H. . . . .	1
6	6004972	STRAP ASSEMBLY, door stop, rear, R.H. . . . .	1
7	6000071P	DOOR ASSEMBLY, rear, L.H. . . . .	1
7	6000072P	DOOR ASSEMBLY, rear, R.H. . . . .	1
8	6008389	SEAL, window channel . . . . .	1
9	6011776	SEAL, belt line . . . . .	2
10	6000248	GASKET, exterior door handle . . . . .	1
11	6002874	HANDLE ASSEMBLY, door exterior, rear. . . . .	1
12	5744555	GLASS AND LIFT CHANNEL, tinted glass, L.H., rear . . . .	1
13	6003516	•GLASS, tinted . . . . .	1
14	6001887	•LIFT CHANNEL . . . . .	1
12	5745128	GLASS AND LIFT CHANNEL, privacy glass, L.H., rear . . . .	1
13	6010780	•GLASS, privacy. . . . .	1
14	6001887	•LIFT CHANNEL . . . . .	1
12	5744554	GLASS AND LIFT CHANNEL, tinted glass, R.H., rear . . . .	1
13	6003516	•GLASS, tinted . . . . .	1
14	6001887	•LIFT CHANNEL . . . . .	1
12	5745129	GLASS AND LIFT CHANNEL, privacy glass, R.H., rear. . . .	1
13	6010780	•GLASS, privacy. . . . .	1
14	6001887	•LIFT CHANNEL . . . . .	1
15	5939037	CLIP, rod end . . . . .	3
16	6011276	ROD, exterior handle to latch, rear . . . . .	2
17	6002906	SLEEVE, latch rod . . . . .	1
18	5938960	LATCH ASSEMBLY, L.H. . . . .	1
18	5938961	LATCH ASSEMBLY, R.H. . . . .	1
19	N/S	NUT AND LOCKWASHER, keps, #10 - 24, ZN. . . . .	4
20	6006447	SEAL, door, black foam, 120" long SEE NOTE 1 . . . . .	1
21	6000061	ROD, interior handle to latch, rear . . . . .	1
22	5939423P2	BOLT . . . . .	6
23	5939223P2	BOLT . . . . .	4
24	5939634P2	WASHER . . . . .	10

# 2001 HUMMER PARTS CATALOG

## 10-58 BODY

ITEM	PART NUMBER	DESCRIPTION	QTY
		<b>Figure 10-21. Door Assembly, Rear, Models 83, 84, and 90. Models, 83, 84, and 90 (Cont'd)</b>	
25	5938962P	HINGE ASSEMBLY, door, L.H. . . . .	2
25	5938963P	HINGE ASSEMBLY, door, R.H. . . . .	2
26	5938896	DOOR LOCK CABLE ASSEMBLY. . . . .	1
27	N/S	SCREW, torx head, M6 - 1.0 x 11 . . . . .	2
28	5938949	WINDOW REGULATOR ASSEMBLY, L.H. . . . .	1
28	5938950	WINDOW REGULATOR ASSEMBLY, R.H. . . . .	1
28	6002870	POWER REGULATOR, L.H. . . . .	1
28	6002871	POWER REGULATOR, R.H. . . . .	1
29	6009112	KNOB, lock . . . . .	1
30	5938951	HANDLE, window regulator. . . . .	1
31	N/S	SCREW, flat head, #10 - 24 x 1, window crank. . . . .	1
32	6000249	HANDLE ASSEMBLY, door interior, L.H. . . . .	1
32	6000250	HANDLE ASSEMBLY, door interior, R.H. . . . .	1
33	9425422P2	SCREW, tapping . . . . .	4
	6001625	WATERSHIELD, L.H., rear door (not illustrated) . . . . .	1
	6001626	WATERSHIELD, R.H., rear door (not illustrated) . . . . .	1
	6011830	SPRING, door latch (not illustrated) . . . . .	1
	6011277	COUPLING, door latch (not illustrated) . . . . .	1



# 2001 HUMMER PARTS CATALOG

## 10-60 BODY

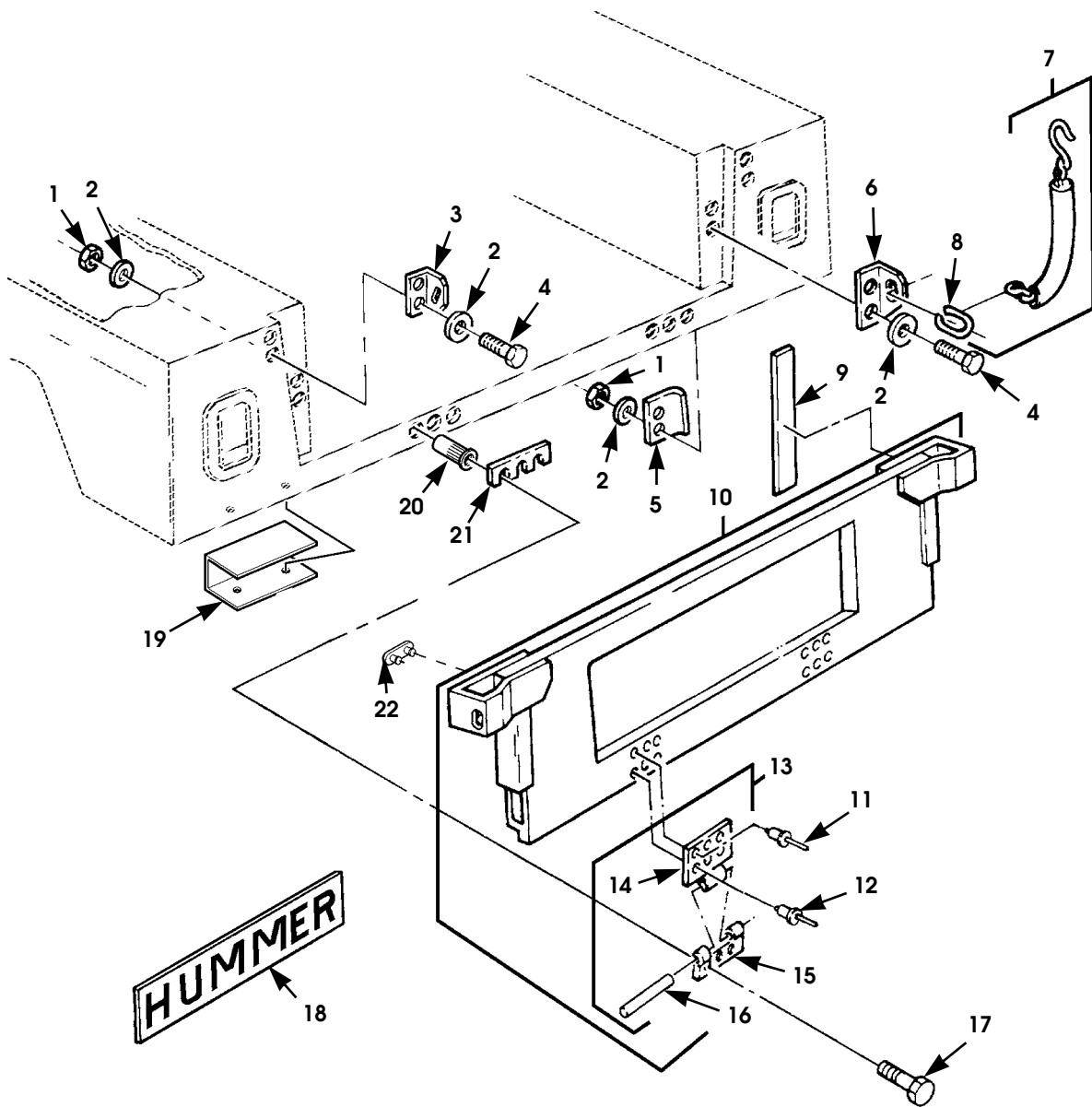

P10-023.3

Figure 10-22. Tailgate Assembly and Related Parts.

# 2001 HUMMER PARTS CATALOG

**BODY 10-61**

ITEM	PART NUMBER	DESCRIPTION	QTY
		<b>Figure 10-22.</b> <b>Tailgate Assembly and Related Parts.</b>	
1	N/S	LOCKNUT, 5/16 - 18, Gr8, latch and bracket . . . . .	8
2	N/S	WASHER, flat, hardened, type B, 5/16, latch and bracket.	16
3	12338974 2P	LATCH, tailgate chain, R.H. . . . .	1
3	12338974 1P	LATCH, tailgate chain, L.H. . . . .	1
4	N/S	BOLT, 5/16 - 18 X 1 1/8, Gr5, latch and bracket . . . . .	8
5	12338977B1	REINFORCEMENT, tailgate chain mount . . . . .	2
6	12338975 1P	BRACKET, chain mount, L.H. . . . .	1
6	12338975 2P	BRACKET, chain mount, R.H. . . . .	1
7	12339227 1P3	COVER AND CHAIN (links and end hook), tailgate, L.H.	1
7	12339227 2P3	COVER AND CHAIN (links and end hook), tailgate, R.H.	1
8	12339223P3	•CONNECTOR, tailgate chain . . . . .	2
9	12339228 9	SEAL, cargo box to tailgate . . . . .	2
		83	
10	WA12338981P	TAILGATE ASSEMBLY . . . . .	1
11	12340354 2	•RIVET, blind, upper . . . . .	6
12	12340354 1	•RIVET, blind, lower . . . . .	6
13	12339985P	•HINGE ASSEMBLY . . . . .	2
14	12339945	••HINGE, tailgate, upper . . . . .	1
15	12339999	••HINGE, tailgate, lower . . . . .	1
16	12339663	••PIN, tailgate hinge . . . . .	1
17	N/S	BOLT, 3/8 - 16 x 1.50, Gr5, lower hinge . . . . .	6
18	6002989	DECAL, "HUMMER", black . . . . .	1
18	5744923	DECAL, "HUMMER", chrome . . . . .	1
18	6002990	DECAL, "HUMMER", gold . . . . .	1
18	5744674	DECAL, "HUMMER", silver . . . . .	1
18	5744673	DECAL, "HUMMER", white . . . . .	1
19	12339008B1	HARNESS COVER, D-beam . . . . .	2
20	N/S	NUT INSERT, 3/8 - 16 . . . . .	6
21	12340045	SHIM, tailgate hinge . . . . .	A/R
22	12339961 2	GROMMET, tailgate . . . . .	2

# 2001 HUMMER PARTS CATALOG

## 10-62 BODY

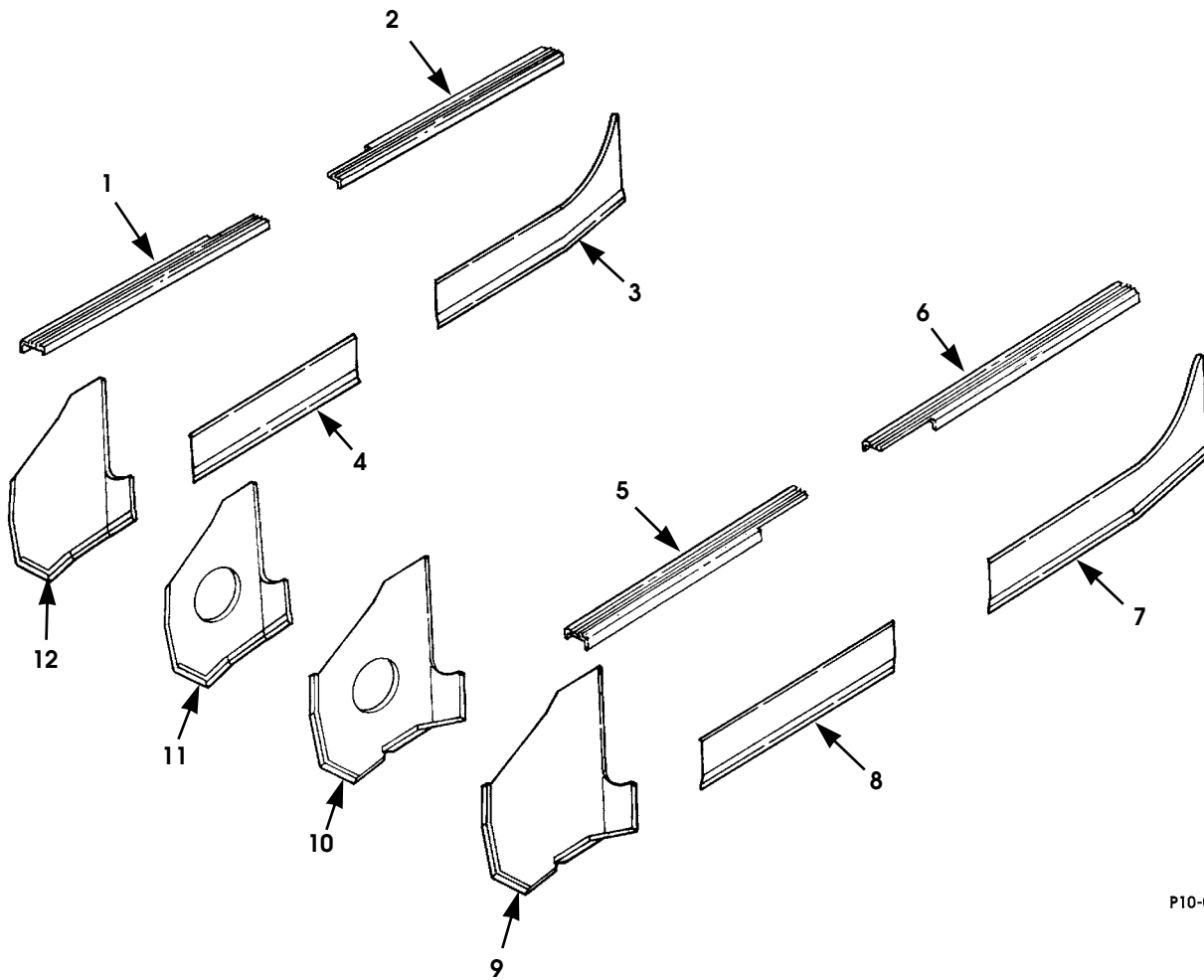

P10-04

Figure 10-23. Outer Kick Panels Interior Trim.

# 2001 HUMMER PARTS CATALOG

**BODY 10-63**

ITEM	PART NUMBER	DESCRIPTION	QTY
		<b>Figure 10-23. Outer Kick Panels Interior Trim.</b>	
1	6000770	SCUFF PLATE ASSEMBLY, front, R.H. ....	1
2	6000772	SCUFF PLATE ASSEMBLY, rear, R.H. ....	1
		83, 84, 90, 91	
3	5939708G	PANEL, outer rear, R.H. gray. ....	1
		83, 84, 90, 91	
3	5939708	PANEL, outer rear, R.H. tan. ....	1
		83, 84, 90, 91	
4	6003436G	PANEL, outer center, R.H., gray. ....	1
4	6003436	PANEL, outer center, R.H., tan. ....	1
		83, 84, 90, 91	
5	6000769	SCUFF PLATE ASSEMBLY, front, L.H. ....	1
6	6000771	SCUFF PLATE ASSEMBLY, rear, L.H. ....	1
		83, 84, 90, 91	
7	6009544G	PANEL, outer rear, L.H. gray. ....	1
		83, 84, 90, 91	
7	6009544	PANEL, outer rear, L.H. tan. ....	1
		83, 84, 90, 91	
8	6003435G	PANEL, outer center, L.H., gray. ....	1
8	6003435	PANEL, outer center, L.H., tan. ....	1
		83, 84, 90, 91	
9	5939705G	PANEL, outer front, L.H., gray. ....	1
		83, 84, 89, 91	
9	5939705	PANEL, outer front, L.H., tan. ....	1
		83, 84, 91	
10	6009139G	PANEL, outer front, L.H., gray. ....	1
		90	
10	6009139	PANEL, outer front, L.H., tan. ....	1
		90	
11	6010468G	PANEL, outer front, R.H., gray. ....	1
		90	
11	6010468	PANEL, outer front, R.H., tan. ....	1
		90	
12	6010467G	PANEL, outer front, R.H., gray. ....	1
		83, 84, 89, 91	
12	6010467	PANEL, outer front, R.H., tan. ....	1
		83, 84, 91	



# 2001 HUMMER PARTS CATALOG

## 10-64 BODY

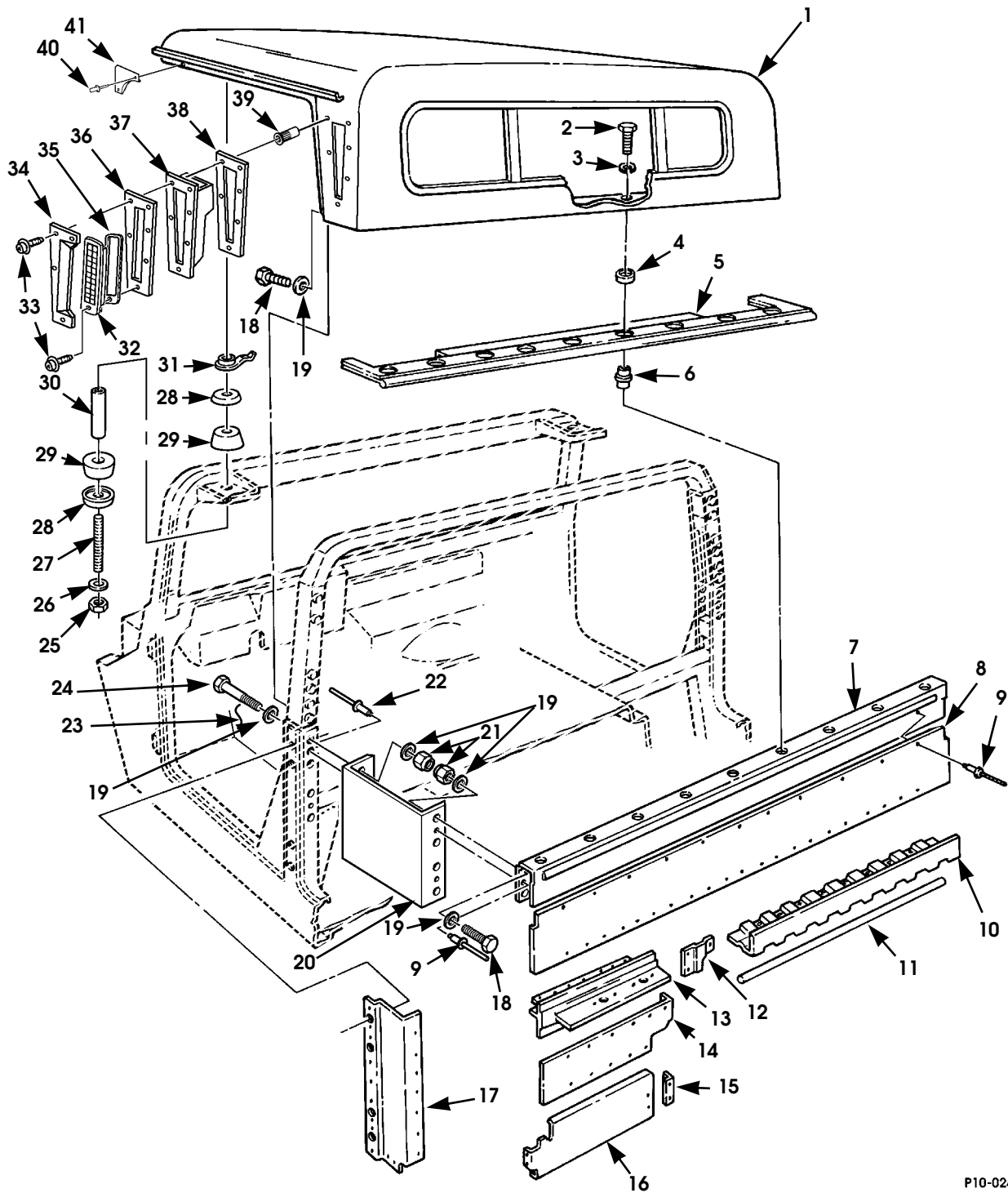

P10-024

Figure 10-24. Roof and Mounting Hardware, Two-Passenger Enlarged Cab, Model 89.

# 2001 HUMMER PARTS CATALOG

**BODY 10-65**

ITEM	PART NUMBER	DESCRIPTION	QTY
		<b>Figure 10-24. Roof and Mounting Hardware, Two-Passenger Enlarged Cab, Model 89.</b>	
1	6009323P	ROOF ASSEMBLY . . . . .	1
2	N/S	BOLT, 1/4 - 20 x 1.0, Gr8, CAD . . . . .	9
3	N/S	LOCKWASHER, med, 1/4, ZN. . . . .	9
4	5939596	SPACER, belt line, rear seal . . . . .	11
5	6004529	SEAL, belt line, rear . . . . .	1
6	5937810	NUT INSERT . . . . .	11
7	5938736	RAIL, upper rear . . . . .	1
8	6004535	PANEL, lower back. . . . .	1
9	12339355 1	RIVET, blind, huck . . . . .	128
10	5938744	BRACKET, back panel support, center . . . . .	1
11	5939988	SEAL, cargo floor/back panel . . . . .	A/R
12	5938749	PANEL, L.H. . . . .	1
12	5938760	PANEL, R.H. . . . .	1
13	6004521P	SUPPORT, footwell cover, L.H. . . . .	1
13	6004522P	SUPPORT, footwell cover, R.H. . . . .	1
14	6004502P	PANEL, footwell, upper, L.H. . . . .	1
14	6004503P	PANEL, footwell, upper, R.H. . . . .	1
15	5938745	BRACKET, closeout panel mounting . . . . .	2
16	6004515P	PANEL, footwell, lower, L.H. . . . .	1
16	6004516P	PANEL, footwell, lower, R.H. . . . .	1
17	6004517P	PANEL, lower back, outer, L.H. . . . .	1
17	6004518P	PANEL, lower back, outer, R.H. . . . .	1
18	N/S	BOLT, 5/16 - 18 x 1 1/8, Gr8, CAD . . . . .	4
19	N/S	WASHER, flat, hardened, type B, 5/16 . . . . .	20
20	6004534	BRACKET, B-pillar-to-upper rear rail . . . . .	1
21	N/S	LOCKNUT, 5/16 - 18, Gr8 . . . . .	10
22	N/S	RIVET, counter sunk, blind, 3/16 . . . . .	4
23	6010009P	PANEL, cowl, inner, L.H. . . . .	1
24	N/S	BOLT, 5/16 - 18 x 4 3/4, Gr8, CAD . . . . .	6
25	N/S	LOCKNUT, 3/8 - 16, Gr8 . . . . .	2
26	N/S	WASHER, flat, hardened, type B, 3/8 . . . . .	2
27	12339559	STUD, roof mount . . . . .	2
28	EC12339561	PLATE, snubber . . . . .	4
29	12339571	MOUNT, roof . . . . .	4
30	12338186 52	SPACER, mount . . . . .	2
31	12339563	PLATE, roof mount . . . . .	2
32	6008778	EXHAUSTER, vent, L.H. . . . .	1
32	6008779	EXHAUSTER, vent, R.H. . . . .	1
33	N/S	SCREW, #8 - 32 x 1/2 . . . . .	14
34	6008855P	LOUVER, ventilation, L.H. . . . .	1
34	6008856P	LOUVER, ventilation, R.H. . . . .	1
35	6009175	GASKET, exhauster, L.H. . . . .	1
35	6009376	GASKET, exhauster R.H. . . . .	1
36	6008853P	PLATE, exhauster mounting . . . . .	2
37	6008849	DUCT, ventilation, L.H. . . . .	1
37	6008850	DUCT, ventilation, R.H. . . . .	1
38	6008851	GASKET, ventilator . . . . .	2
39	6003638	NUT INSERT, #8 - 32 . . . . .	12
40	N/S	RIVET, pop, 1/8" . . . . .	2
41	6000242	FILLER, corner closeout, roof asm-to-w/s frame . . . . .	2

# 2001 HUMMER PARTS CATALOG

## 10-66 BODY

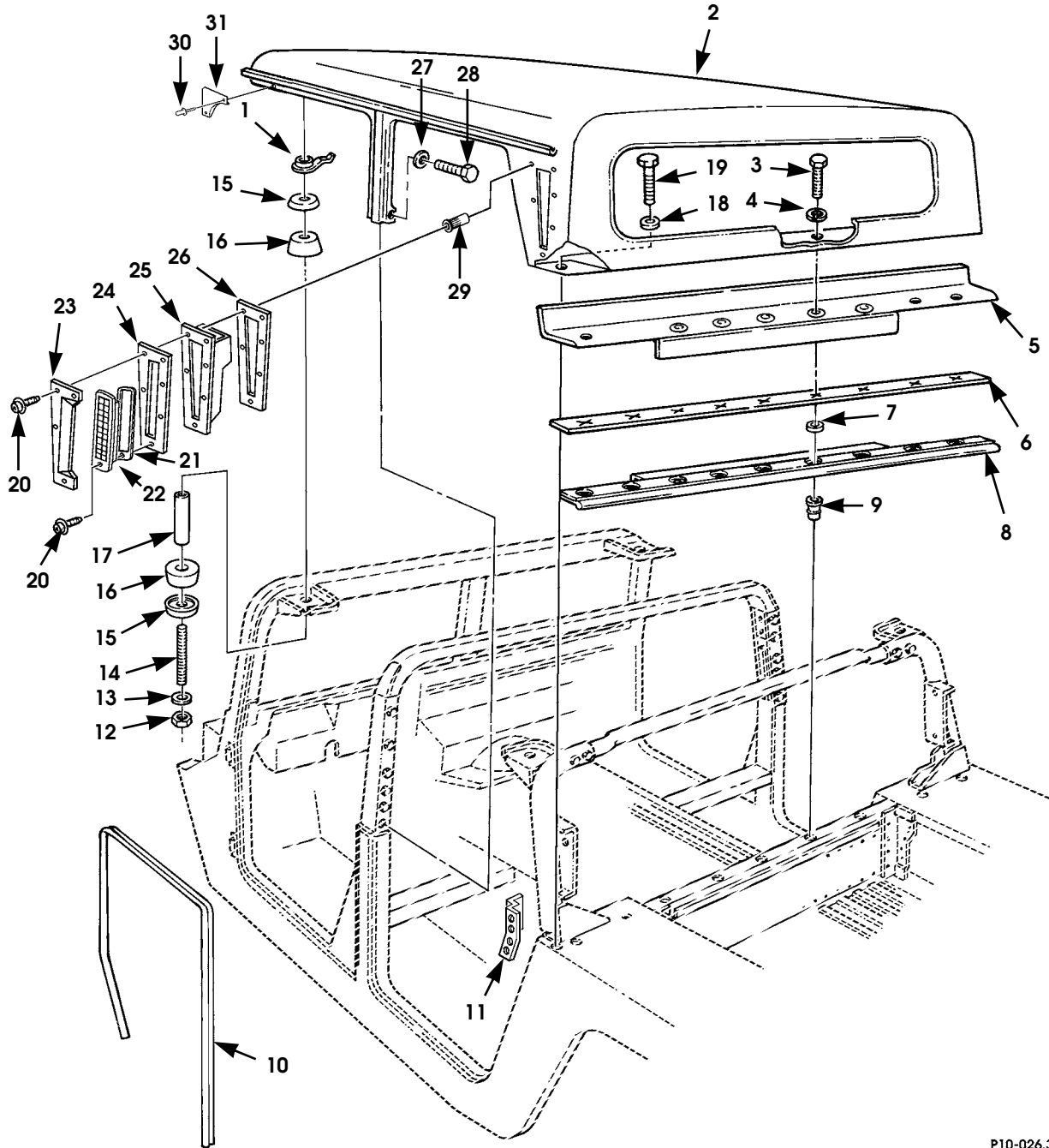

P10-026.3

Figure 10-25. Roof and Mounting Hardware, Four-Passenger Hardtop, Model 83.

# 2001 HUMMER PARTS CATALOG

**BODY 10-67**

ITEM	PART NUMBER	DESCRIPTION	QTY
		<b>Figure 10-25. Roof and Mounting Hardware, Four-Passenger Hard-top, Model 83.</b>	
1	12339563	PLATE, roof mount . . . . .	4
2	6009137P	ROOF ASSEMBLY . . . . .	1
3	N/S	BOLT, 1/4 - 20 x 1.0, Gr8, CAD . . . . .	9
4	N/S	LOCKWASHER, med, 1/4, ZN . . . . .	9
5	6003844B2	TONNEAU BRACKET . . . . .	1
6	6003848	SEAL, tonneau bracket-to-roof . . . . .	1
7	5939596	SPACER, belt line, rear . . . . .	9
8	6000778	SEAL, belt line, rear . . . . .	1
9	5937810	NUT, insert . . . . .	9
10	N/S	SEAL, body, black rubber, 10-foot SEE NOTE 1 . . . . .	1
11	6005456	PANEL, filler, rear, L.H. . . . .	1
11	6005457	PANEL, filler, rear, R.H. . . . .	1
12	N/S	LOCKNUT, 3/8 - 16, Gr8 . . . . .	4
13	N/S	WASHER, flat, hardened, type B, 3/8 . . . . .	4
14	12339559	STUD, roof mount . . . . .	4
15	12339561	PLATE, snubber . . . . .	8
16	12339571	MOUNT, roof . . . . .	8
17	12338186 52	SPACER, mount . . . . .	4
18	N/S	WASHER, flat, 1/4, CAD . . . . .	4
19	N/S	BOLT, 1/4 - 20 x .75, Gr5, CAD . . . . .	4
20	N/S	SCREW, #8-32 x .50 . . . . .	14
21	6009175	GASKET, exhauster, L.H. . . . .	1
21	6009376	GASKET, exhauster, R.H. . . . .	1
22	6008778	EXHAUSTER, vent, L.H. . . . .	1
22	6008779	EXHAUSTER, vent, R.H. . . . .	1
23	6008855P	LOUVER, ventilation, L.H. . . . .	1
23	6008856P	LOUVER, ventilation, R.H. . . . .	1
24	6008853P	PLATE, exhauster mounting . . . . .	2
25	6008849	DUCT, ventilation, L.H. . . . .	1
25	6008850	DUCT, ventilation, R.H. . . . .	1
26	6008851	GASKET, ventilator . . . . .	2
27	N/S	WASHER, flat, 5/16 . . . . .	8
28	N/S	SCREW, phcr, 5/16 - 18 x 5/8 . . . . .	4
29	6003638	NUT INSERT . . . . .	14
30	N/S	RIVET, pop, 1/8" . . . . .	2
31	6000242	FILLER, corner closeout, roof asm-to-w/s frame . . . . .	2
		NOTE 1: CUT TO LENGTH FROM 50' BULK ROLL OF BODY SEAL P/N 5744322.	

# 2001 HUMMER PARTS CATALOG

## 10-68 BODY

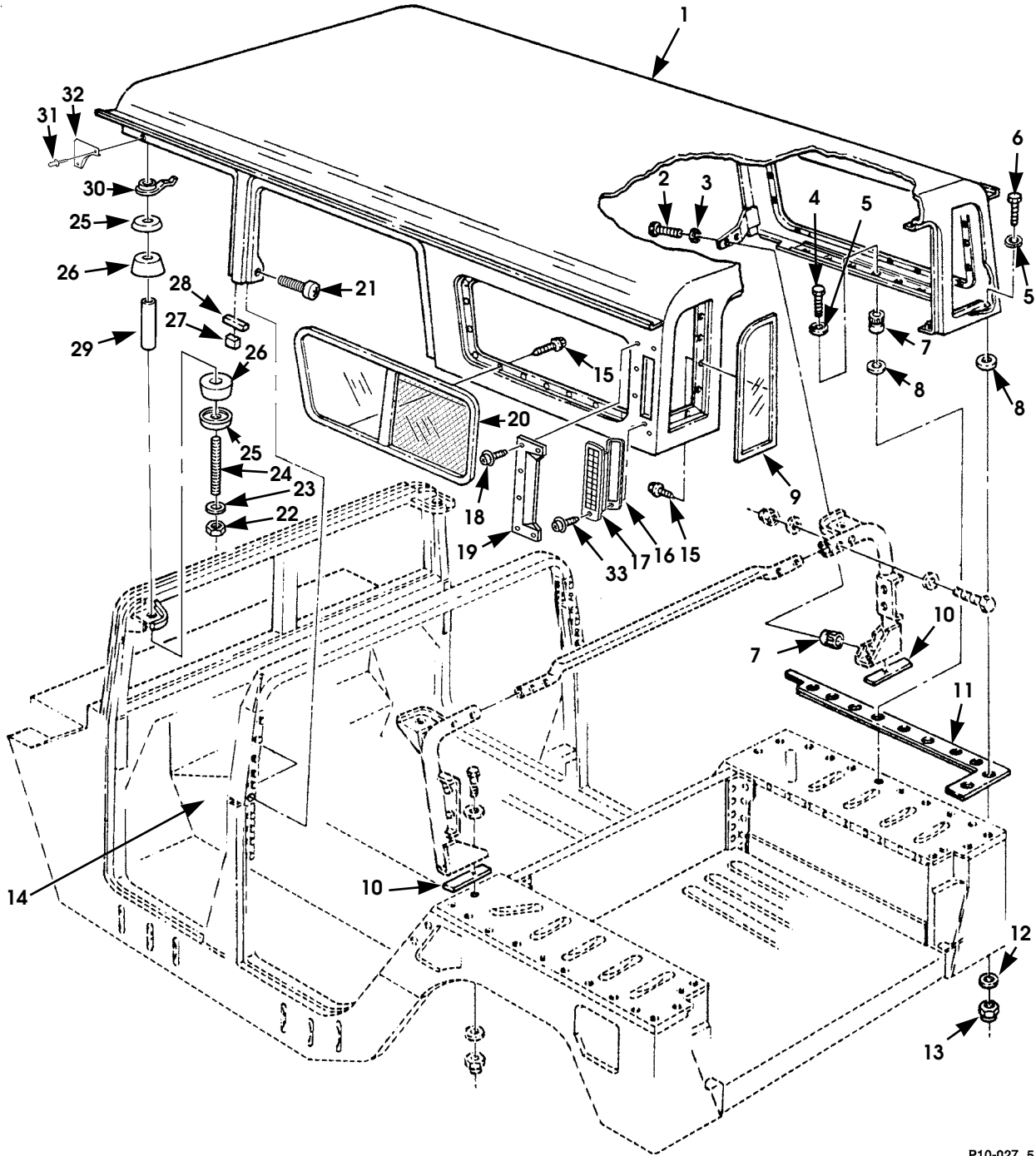

P10-027. 5

Figure 10-26. Roof and Mounting Hardware, Station Wagon, Model 84.

# 2001 HUMMER PARTS CATALOG

**BODY 10-69**

ITEM	PART NUMBER	DESCRIPTION	QTY
		<b>Figure 10-26. Roof and Mounting Hardware, Station Wagon, Model 84 .</b>	
1	6009138P	ROOF ASSEMBLY . . . . .	1
2	N/S	BOLT, 1/4 - 20 x 3/4, Gr5 . . . . .	4
3	N/S	WASHER, flat, 1/4, CAD . . . . .	4
4	N/S	BOLT, 1/4 - 20 x 1 , Gr8, CAD . . . . .	14
5	N/S	LOCKWASHER, med, 1/4 . . . . .	24
6	N/S	BOLT, 1/4 - 20 x 1 1/4, Gr8, CAD . . . . .	10
7	5937810	NUT INSERT . . . . .	18
8	5939596	SPACER, roof to wheel well . . . . .	24
9	6010776	OPERA WINDOW ASSEMBLY, privacy, L.H. . . . .	1
9	6010777	OPERA WINDOW ASSEMBLY, privacy, R.H. . . . .	1
9	6003523	OPERA WINDOW ASSEMBLY, tinted, L.H. . . . .	1
9	6003524	OPERA WINDOW ASSEMBLY, tinted, R.H. . . . .	1
10	12338186 52	SPACER, C-Pillar support . . . . .	2
11	6008858	SEAL, side, L.H., roof to wheel well . . . . .	1
11	6008859	SEAL, side, R.H., roof to wheel well . . . . .	1
12	9414920	WASHER, flat . . . . .	10
13	N/S	LOCKNUT, 1/4 - 20, Gr8 . . . . .	10
14	601009P	PANEL, cowl, inner, L.H. . . . .	1
15	N/S	SCREW, #8 - 18 x 1/2 . . . . .	72
16	6009175	GASKET, exhauster, L.H. . . . .	1
16	6009376	GASKET, exhauster, R.H. . . . .	1
17	6008778	EXHAUSTER, vent, L.H. . . . .	1
17	6008779	EXHAUSTER, vent, R.H. . . . .	1
18	6008857	SCREW . . . . .	12
19	6008764P	COVER, vent exhauster. . . . .	2
20	6010774	WINDOW AND SCREEN ASSEMBLY, side, privacy, L.H. . . . .	1
20	6010775	WINDOW AND SCREEN ASSEMBLY, side, privacy, R.H. . . . .	1
20	6003521	WINDOW AND SCREEN ASSEMBLY, side, tinted, L.H. . . . .	1
20	6003522	WINDOW AND SCREEN ASSEMBLY, side, tinted, R.H. . . . .	1
21	N/S	SCREW, phcr, 5/16 - 18 x 5/8 . . . . .	4
22	N/S	LOCKNUT, 3/8 - 16, Gr8 . . . . .	4
23	N/S	WASHER, flat, 3/8, type B . . . . .	4
24	12339559	STUD, roof mount . . . . .	4
25	12339561	PLATE, snubber. . . . .	8
26	12339571	ROOF mount . . . . .	8
27	6000240	SEAL, B-pillar, lower. . . . .	2
28	6000241	SEAL, B-pillar, upper . . . . .	2
29	12338186 52	SPACER, roof mount. . . . .	4
30	12339563	PLATE, roof mount . . . . .	4
31	N/S	RIVET, blind, 1/8" . . . . .	2
32	6000242	FILLER, corner closeout, roof asm-to-w/s frame . . . . .	2
33	N/S	SCREW, #8-32 x 1/2 . . . . .	2

# 2001 HUMMER PARTS CATALOG

## 10-70 BODY

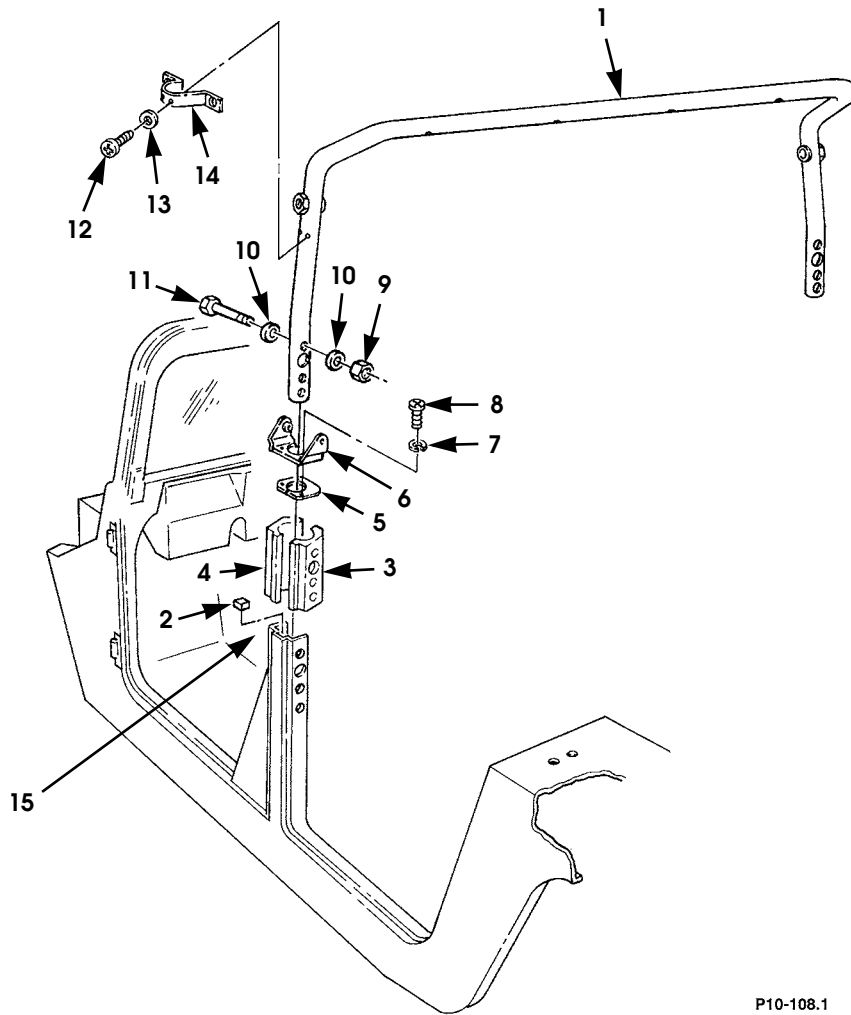

P10-108.1

Figure 10-27. B-Bar, Two-Passenger Enlarged Cab, Model 89.

# 2001 HUMMER PARTS CATALOG

**BODY 10-71**

ITEM	PART NUMBER	DESCRIPTION	QTY
		<b>Figure 10-27.</b> <b>B-Bar, Two-Passenger Enlarged Cab, Model 89.</b>	
1	6004532	B-BAR ASSEMBLY . . . . .	1
2	6000240	SEAL, rabbet B-pillar . . . . .	2
3	6005458	CONNECTION BLOCK, Rear . . . . .	2
4	6005459	CONNECTION BLOCK, Forward . . . . .	2
5	6005156	SEAL, B-pillar . . . . .	2
6	6004541	BRACKET, B-pillar cover mounting . . . . .	2
7	N/S	LOCKWASHER, med, #10, ZN. . . . .	4
8	N/S	SCREW, tapping, phcr, #10 - 24 x 3/4 . . . . .	4
9	N/S	LOCKNUT, 5/16 - 18, Gr8 . . . . .	6
10	N/S	WASHER, flat, hardened, type B, 5/16 . . . . .	12
11	N/S	BOLT, B-pillar, 5/16 - 18 x 4-3/4, Gr8. . . . .	6
12	N/S	SCREW, #10 - 24 x 1/2 . . . . .	12
13	N/S	WASHER, flat, type B, #10, ZN. . . . .	12
14	6005145	BRACKET, trim mounting . . . . .	2
15	6010009P	PANEL, cowl, inner, L.H. . . . .	1



# 2001 HUMMER PARTS CATALOG

## 10-72 BODY

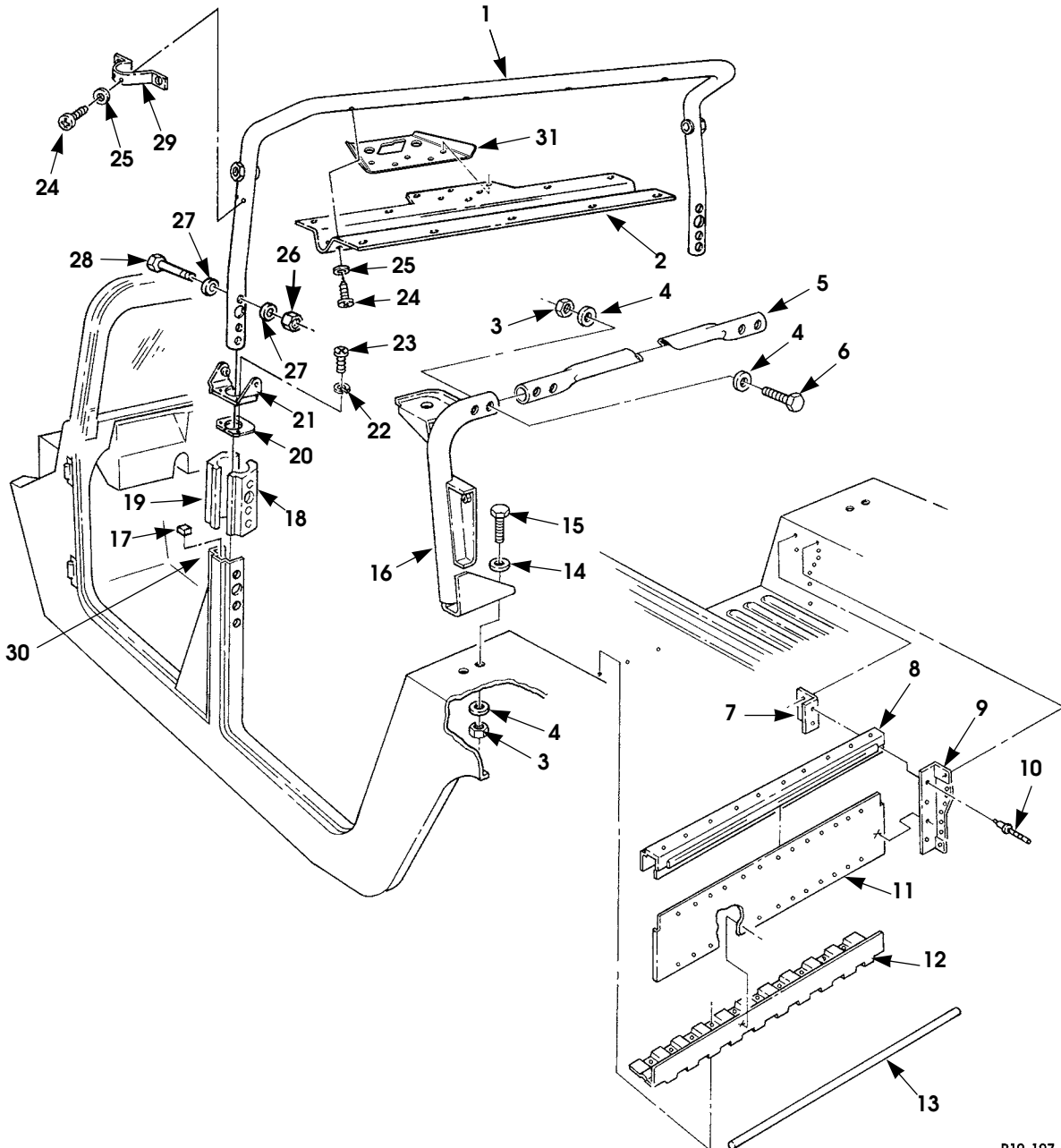

P10-107.1

*Figure 10-28. B- and C-Bars, Four-Passenger Hardtop and Station Wagon, Models 83 and 84.*

# 2001 HUMMER PARTS CATALOG

**BODY 10-73**

ITEM	PART NUMBER	DESCRIPTION	QTY
		<b>Figure 10-28. B- and C-Bars, Four-Passenger Hardtop and Station Wagon, Models 83 and 84.</b>	
1	6004532	B-BAR ASSEMBLY . . . . .	1
2	6009460	SUPPORT, headliner . . . . .	1
3	N/S	LOCKNUT, 5/16 - 24, Gr8 . . . . .	8
4	N/S	WASHER, flat, hardened, type B, 3/8 . . . . .	12
5	5937106	C-PILLAR, intermediate . . . . .	1
6	N/S	BOLT, 3/8 - 16 x 3, Gr8, CAD . . . . .	4
7	5938792	ANGLE, rail to wheelhouse, L.H. . . . .	1
7	5939304	ANGLE, rail to wheelhouse, R.H. . . . .	1
8	5938790	RAIL ASSEMBLY, upper rear . . . . .	1
9	5938787	BRACKET, lower back panel, L.H. . . . .	1
9	5938788	BRACKET, lower back panel, R.H. . . . .	1
10	12339355 1	RIVET, blind, huck, 3/16 . . . . .	75
11	5938775	PANEL, lower back . . . . .	2
12	5938789	BRACKET, cargo floor . . . . .	1
13	5939988	SEAL, cargo floor/back panel . . . . .	1
14	12340880	WASHER, flat . . . . .	4
15	N/S	BOLT, 3/8 - 16 x 1.5, Gr8, CAD . . . . .	4
16	5938814B9	C-PILLAR ASSEMBLY, L.H. . . . .	1
16	5938815B9	C-PILLAR ASSEMBLY, R.H. . . . .	1
17	6000240	SEAL, rabbet B-pillar . . . . .	2
18	12340090 1	CONNECTION BLOCK, Rear . . . . .	2
19	12340090 2	CONNECTION BLOCK, Forward . . . . .	2
20	6005156	SEAL, B-pillar . . . . .	2
21	6004541	BRACKET, B-pillar cover mounting . . . . .	2
22	N/S	LOCKWASHER, med, #10, ZN . . . . .	4
23	N/S	SCREW, tapping, phcr, #10 - 24 x 3/4 . . . . .	4
24	N/S	SCREW, tapping, phcr, #10 - 24 x 1/2 . . . . .	12
25	N/S	WASHER, flat, type B, #10, ZN . . . . .	12
26	N/S	NUT, 5/16 - 18, Gr8 . . . . .	6
27	N/S	WASHER, flat, hardened, type B, 5/16, ZN . . . . .	12
28	N/S	BOLT, 5/16 - 18 x 4 3/4, Gr8, B-pillar . . . . .	6
29	6005145	BRACKET, trim mounting . . . . .	2
30	6010009P	PANEL, cowl, inner, L.H. . . . .	1
31	6002967B2	BRACKET, dome light . . . . .	1



# 2001 HUMMER PARTS CATALOG

BODY 10-75

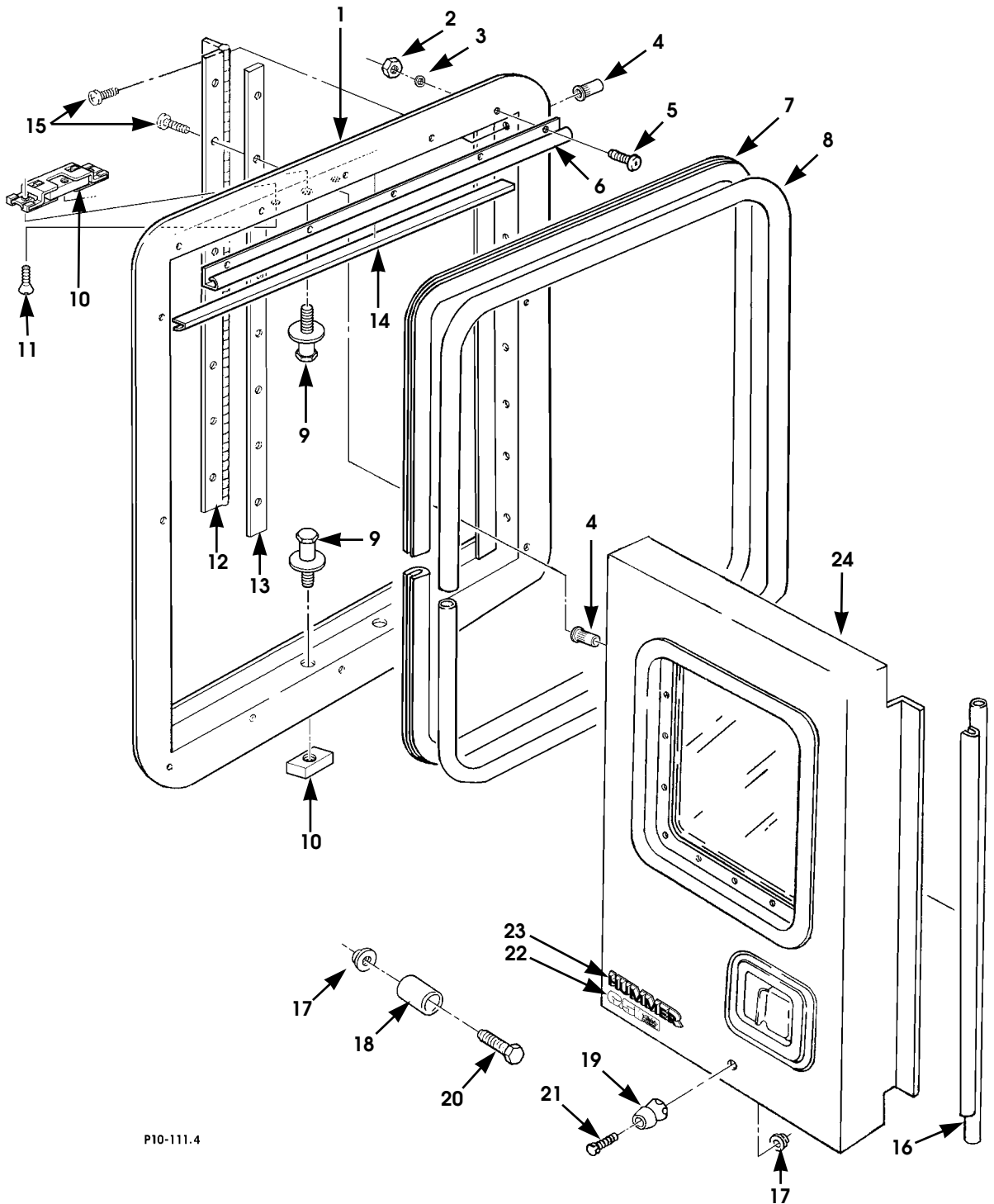

Figure 10-29. Station Wagon Rear Doors, Model 84  
(Sheet 1 of 2)

AM General Corporation

5745278

# 2001 HUMMER PARTS CATALOG

## 10-76 BODY

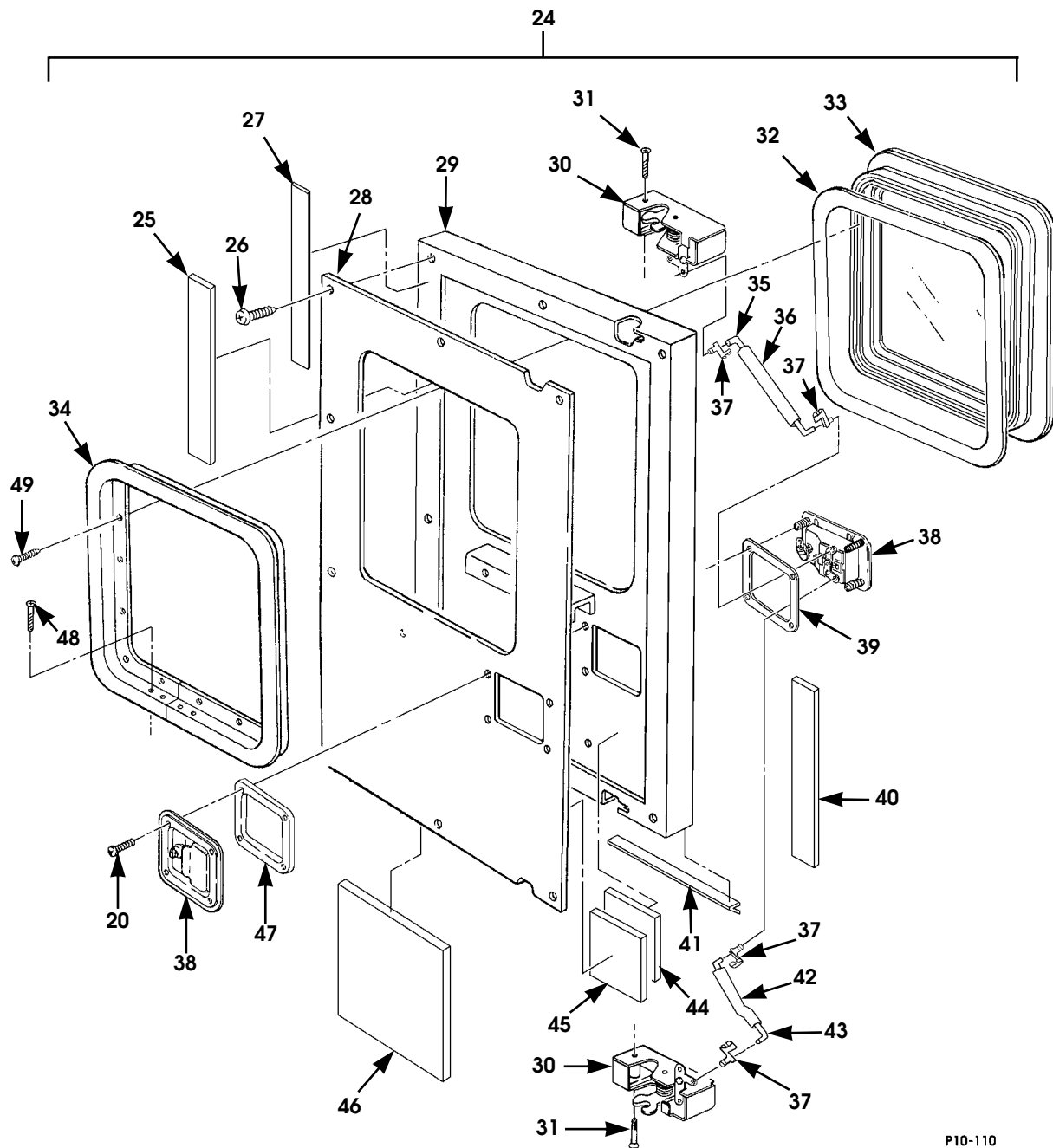

P10-110

Figure 10-29. Station Wagon Rear Doors, Model 84  
(Sheet 2 of 2).

# 2001 HUMMER PARTS CATALOG

**BODY 10-77**

ITEM	PART NUMBER	DESCRIPTION	QTY
		<b>Figure 10-29.</b> <b>Station Wagon Rear Doors, Model 84</b>	
1	6008355P	FRAME ASSEMBLY, rear doors . . . . .	1
2	N/S	NUT, 1/4 - 20, ZN . . . . .	17
3	N/S	LOCKWASHER, med, 1/4, ZN. . . . .	17
4	5937842	NUTSERT, 1/4 - 20 closed . . . . .	30
5	N/S	SCREW, torx, buttonhead, 1/4 - 20 x 1 1/4 . . . . .	17
6	6005773P	DRIP RAIL . . . . .	1
7	5744343	EDGE SEAL, vertical doors SEE NOTE 1. . . . .	1
8	5744344	DOOR SEAL, vertical doors SEE NOTE 2. . . . .	1
9	6006828	STRIKER , bottom . . . . .	2
9	6005629	STRIKER, top . . . . .	2
10	6005630	CAGE NUT ASSEMBLY, top striker. . . . .	2
10	6006840	PLATE NUT, bottom striker . . . . .	2
11	N/S	SCREW, flathead, 1/4 - 20 x 1/2 . . . . .	8
12	6005639	HINGE, rear door, L.H. . . . .	1
12	6008343	HINGE, rear door, RH . . . . .	1
13	6005767	SEAL, hinge-to-frame. . . . .	4
14	6009486	V-SEAL, 48", rear door top SEE NOTE 3 . . . . .	1
15	N/S	SCREW, torx, buttonhead, 1/4 - 20 x 1 . . . . .	32
16	6005772	SEAL, left door, center . . . . .	1
17	5937584	NUT, insert, door hold-open assembly . . . . .	4
18	6005656	DOOR HOLD-OPEN ASSEMBLY . . . . .	2
19	S.I.A.	•BALL PLUG, door hold-open assembly . . . . .	2
20	N/S	SCREW, 1/4 - 20 x 1 . . . . .	10
21	N/S	SCREW, fillister head, socket head, 1/4 - 20 x 1 1/2, door hold-open assembly . . . . .	2
22	6008595	EMBLEM "6.5L TURBO DIESEL" . . . . .	1
23	6003871	NAMEPLATE "HUMMER" . . . . .	1
24	6008358P	DOOR ASSEMBLY, R.H. . . . .	1
24	6005939P	DOOR ASSEMBLY, L.H. . . . .	1
25	6006433	•INSULATION, upper, vertical door. . . . .	1
26	6006283	•SCREW . . . . .	16
27	5744346	•SEAL, door panel frame SEE NOTE 4 . . . . .	1
28	6005668P	•DOOR PANEL, interior, R.H. . . . .	1
28	6005669P	•DOOR PANEL, interior, L.H.. . . . .	1
29	6008357P	•DOOR FRAME, rear, R.H. . . . .	1
29	6005665P	•DOOR FRAME, rear, L.H. . . . .	1
30	6005627	•LATCH ASSEMBLY, rotary, upper R.H., lower L.H. . . . .	1
30	6005628	•LATCH ASSEMBLY, rotary, upper L.H., lower R.H. . . . .	1
31	N/S	•SCREW, flathead, 1/4 - 20 x 1 1/2, CAD . . . . .	6
32	6005932	•SEAL, window assembly, rear doors. . . . .	1

# 2001 HUMMER PARTS CATALOG

## 10-78 BODY

ITEM	PART NUMBER	DESCRIPTION	QTY
		<b>Figure 10-29.</b> <b>Station Wagon Rear Doors, Model 84</b>	
33	6005634	•WINDOW, rear doors, tinted glass, SEE NOTE 5 . . . . .	1
33	6010778	•WINDOW, rear doors, privacy glass, SEE NOTE 5 . . . . .	2
34	S.I.A.	••OUTER FRAME, rear doors . . . . .	1
35	6005769	•ROD, upper, latch . . . . .	1
36	6006435	•SLEEVE, upper lock rod . . . . .	1
37	6000747	•CLIP, rod, interior handle . . . . .	4
38	6005632	•HANDLE ASSEMBLY, exterior, L.H. . . . .	1
38	6009572	•HANDLE ASSEMBLY, exterior/interior, R.H. . . . .	1
39	6000248	•GASKET, exterior handle . . . . .	1
40	6006272	•INSULATION, 18" x 1.5" x .75" . . . . .	1
40	6006273	•INSULATION, 18" x 1.5" x .5" . . . . .	1
41	6006434	•V-SEAL, vertical door sill, 23.5" . . . . .	2
42	6006282	•SLEEVE, lower lock rod . . . . .	1
43	6005770	•ROD, lower latch, L.H. . . . .	1
43	6005657	•ROD, lower latch, R.H. . . . .	1
44	6006274	•INSULATION, 1.5" x 1.5" x .75" . . . . .	1
45	6006275	•INSULATION, 1.5" x 1.5" x .5" . . . . .	1
46	6006432	•INSULATION, lower, vertical door . . . . .	1
47	6005633	•SPACER, interior handle . . . . .	1
48	S.I.A.	•SCREW, #8 - 18 x 1/2, TEKS . . . . .	4
49	S.I.A.	•SCREW, #8 - 18 x 3/4, TEKS . . . . .	12
		NOTE 1: ORDER BY FOOT FROM BULK SEAL, VERTICAL DOORS, P/N 6006218, 500-FT ROLL, 14 FEET REQUIRED PER VEHICLE	
		NOTE 2: ORDER BY FOOT FROM BULK SEAL, VERTICAL DOORS, P/N 6006219, 500-FT ROLL, 14 FEET REQUIRED PER VEHICLE	
		NOTE 3: ORDER BY FOOT FROM BULK V-SEAL, VERTICAL DOOR SILL, P/N 6009706, 500-FT ROLL, 4.75 FEET REQUIRED PER VEHICLE	
		NOTE 4: ORDER BY FOOT FROM BULK SEAL, DOOR PANEL-TO-DOOR FRAME, P/N 6006217, 150-FT ROLL, 4.5 FEET REQUIRED PER VEHICLE	
		NOTE 5: TINTED GLASS REAR DOOR WINDOW P/N 6005634 IS STANDARD; PRIVACY GLASS REAR DOOR WINDOW P/N 6010778 IS OPTIONAL.	





# 2001 HUMMER PARTS CATALOG

## 10-80 BODY

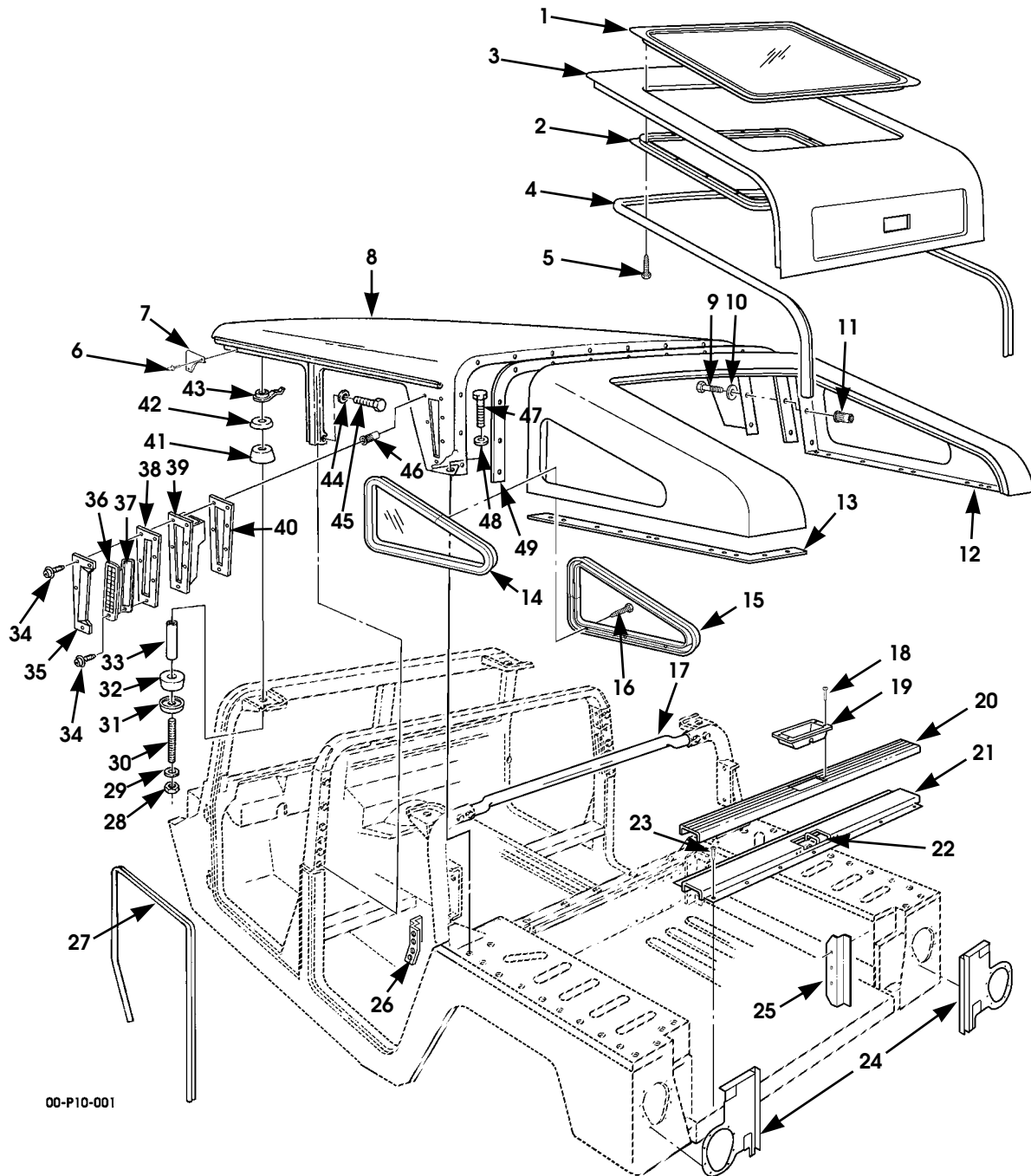

Figure 10-30. Roof, Slant-Back Door, and Mounting Hardware, Slant-Back, Model 91.

# 2001 HUMMER PARTS CATALOG

**BODY 10-81**

ITEM	PART NUMBER	DESCRIPTION	QTY
		<b>Figure 10-30. Roof, Slant-Back Door, and Mounting Hardware, Slant-Back, Model 91.</b>	
1	6010947	GLASS ASSEMBLY, slant-back door, privacy, plain. . . . .	1
1	6010948	GLASS ASSEMBLY, slant-back door, privacy, heated . .	1
2	S.I.A.	•OUTER FRAME, door window . . . . .	1
3	6010862	DOOR ASSEMBLY, riveted . . . . .	1
4	6011671	SEAL . . . . .	1
5	N/S	SCREW, flanged, tapping, #8 - 18 x 3/4 . . . . .	22
6	N/S	RIVET, blind, 1/8 . . . . .	4
7	6000242	FILLER, corner closeout, roof assembly-to-w/s frame .	2
8	6010060	ROOF ASSEMBLY, welded . . . . .	1
9	N/S	BOLT, 1/4 - 20 x 1 . . . . .	16
9	N/S	BOLT, 1/4 - 20 x 1 1/4 . . . . .	6
9	N/S	BOLT, 1/4 - 20 x 1 3/8 . . . . .	4
10	N/S	WASHER, flat, 1/4 . . . . .	26
11	5937810	NUTSERT . . . . .	26
12	6010861	SHELL ASSEMBLY . . . . .	1
13	6011861	SEAL, side panel, L.H. . . . .	1
13	6011862	SEAL, side panel, R.H. . . . .	1
14	6010943	GLASS AND FRAME, L.H. . . . .	1
14	6010946	GLASS AND FRAME, R.H. . . . .	1
15	S.I.A.	•OUTER FRAME, side glass . . . . .	1
16	6001285	SCREW, tapping, #8 -18 x 3/4 . . . . .	13
17	6010059	C-PILLAR INTERMEDIATE . . . . .	1
18	N/S	SCREW, tapping, fhcr, #10 . . . . .	4
19	6010924	TRIM PIECE, striker. . . . .	1
20	6010923	SCUFF PLATE, rear sill . . . . .	1
21	6010918	RAIL ASSEMBLY, striker mounting. . . . .	1
22	6010920	•RAIL STRIKER MOUNTING. . . . .	1
23	N/S	SCREW, tapping phcr, #10 - 24 x 3/4 . . . . .	13
24	6010916P	PANEL, wheel house rear filler, L.H. . . . .	1
24	6010917P	PANEL, wheelhouse rear filler, R.H. . . . .	1
25	6010896P	GUTTER, wheelhouse filler, L.H. . . . .	1
25	6010899P	GUTTER, wheelhouse filler, R.H. . . . .	1
26	6005456	PANEL, filler, rear, L.H. . . . .	1
26	6005457	PANEL, filler, rear, R.H. . . . .	1
27	N/S	SEAL, body, black rubber, 10', SEE NOTE 1. . . . .	1
28	N/S	LOCKNUT, 3/8 - 16, Gr8 . . . . .	4
29	N/S	WASHER, flat, hardened, type B, 3/8 . . . . .	4
30	12339559	STUD, roof mount . . . . .	4
31	12339571	MOUNT, roof . . . . .	8

# 2001 HUMMER PARTS CATALOG

## 10-82 BODY

ITEM	PART NUMBER	DESCRIPTION	QTY
		<b>Figure 10-30. Roof, Slant-Back Door, and Mounting Hardware, Slant-Back, Model 91. (Cont'd.)</b>	
32	12338561	PLATE, snubber . . . . .	8
33	12338186 52	SPACER, mount. . . . .	4
34	N/S	SCREW, #8 - 32 x 1/2. . . . .	14
35	6008855P	LOUVER, ventilation, L.H. . . . .	1
35	6008856P	LOUVER, ventilation, R.H. . . . .	1
36	6008778	EXHAUSTER, vent, L.H. . . . .	1
36	6008779	EXHAUSTER, vent, R.H. . . . .	1
37	6009175	GASKET, exhauster, L.H. . . . .	1
37	6009376	GASKET, exhauster, R.H. . . . .	1
38	6008853P	PLATE, exhauster mounting. . . . .	2
39	6008850	DUCT, ventilation, R.H. . . . .	1
39	6008849	DUCT, ventilation, L.H. . . . .	1
40	6008851	GASKET, ventilator . . . . .	2
41	12339571	MOUNT, roof . . . . .	8
42	12339561	PLATE, snubber . . . . .	8
43	12339563	PLATE, roof mount . . . . .	2
44	N/S	WASHER, flat, 5/16 . . . . .	8
45	N/S	SCREW, phcr, 5/16 - 18 x 5/8 . . . . .	4
46	6003638	NUT INSERT . . . . .	14
47	N/S	BOLT, 1/4 - 20 x 1 1/4, GR8, CAD . . . . .	4
48	N/S	WASHER, flat, 1/4, CAD. . . . .	4
49	6011860	SEAL, roof-to-slant-back . . . . .	1
		NOTE 1: CUT TO LENGTH FROM 50' BULK ROLL OF BODY SEAL, P/N 5744322.	



# 2001 HUMMER PARTS CATALOG

## 10-84 BODY

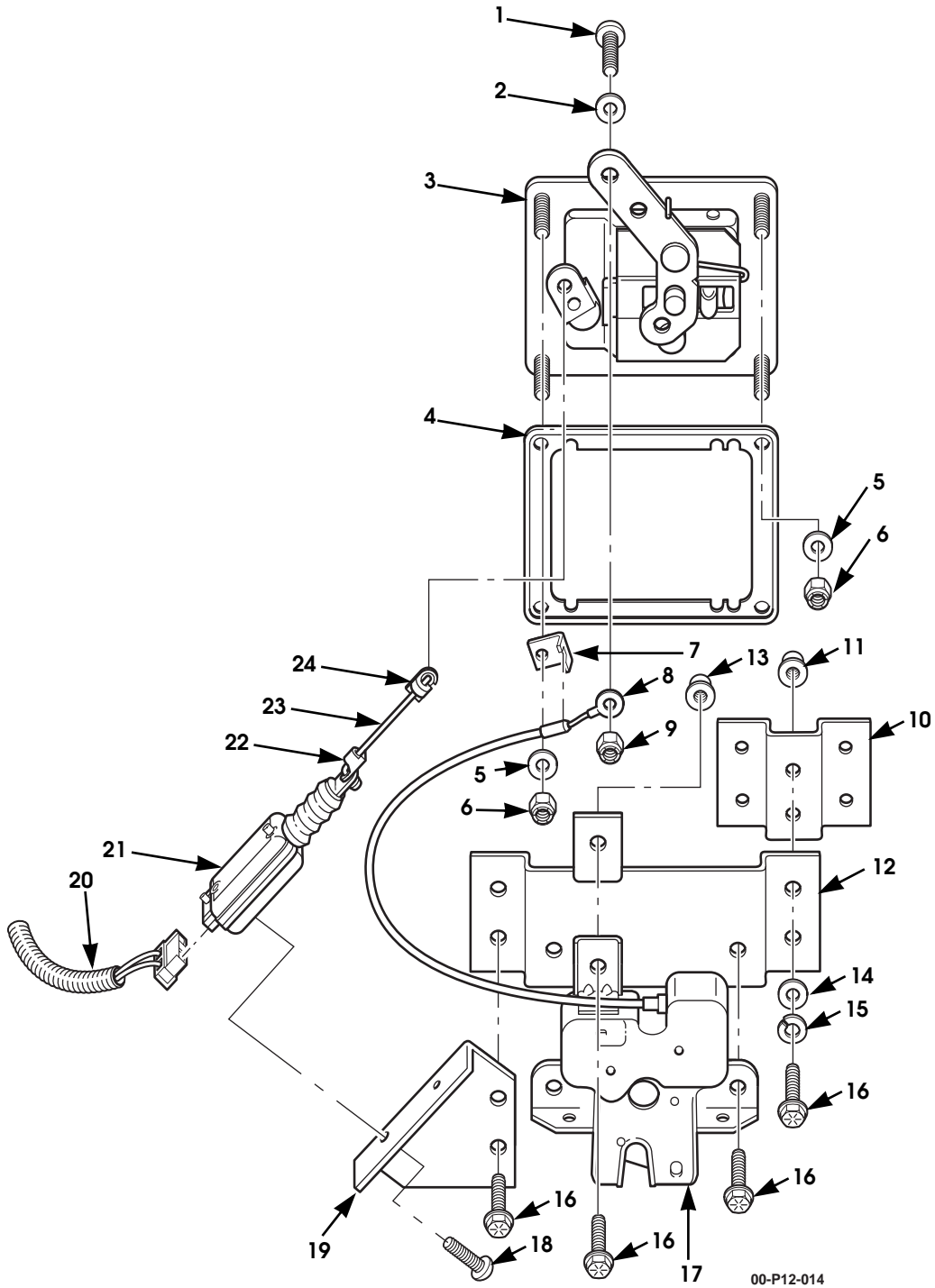

00-P12-014

Figure 10-31. Slant-Back Door Latch Assembly

# 2001 HUMMER PARTS CATALOG

**BODY 10-85**

ITEM	PART NUMBER	DESCRIPTION	QTY
		<b>Figure 10-31. Slant-Back Door Latch Assembly</b>	
1	N/S	SCREW, phillips head, 1/4 - 20 x 1/2 . . . . .	1
2	N/S	WASHER, flat, 1/4 . . . . .	1
3	6011803	DOOR HANDLE ASSEMBLY . . . . .	1
4	6000248	GASKET, exterior door handle . . . . .	1
5	9416128	WASHER, flat . . . . .	4
6	190254	LOCKNUT . . . . .	4
7	6010910	BRACKET, door release cable . . . . .	1
8	6010911	CABLE ASSEMBLY, door release . . . . .	1
9	N/S	LOCKNUT, 1/4 - 20 . . . . .	1
10	6010879	PANEL ASSEMBLY, latch mounting . . . . .	2
11	S.I.A.	•NUT INSERT, 1/4 - 20 . . . . .	4
12	6010892	BRACKET ASSEMBLY, latch mounting . . . . .	1
13	S.I.A.	•NUT INSERT, 1/4 - 20 . . . . .	3
14	N/S	WASHER, flat, 1/4 . . . . .	4
15	N/S	LOCKWASHER . . . . .	4
16	N/S	BOLT, 1/4 - 20 x 3/4 . . . . .	4
17	6010046	DOOR LATCH ASSEMBLY . . . . .	1
18	6006283	SCREW, truss head . . . . .	1
19	6010913	BRACKET, actuator mounting . . . . .	1
20	6011051	HARNES, slant-back . . . . .	1
21	6003590	ACTUATOR . . . . .	1
22	5939037	END CLIP, yellow rod . . . . .	1
23	6010909	ROD, actuator-to-door lock . . . . .	1
24	6000747	ROD CLIP . . . . .	1

# 2001 HUMMER PARTS CATALOG

## 10-86 BODY

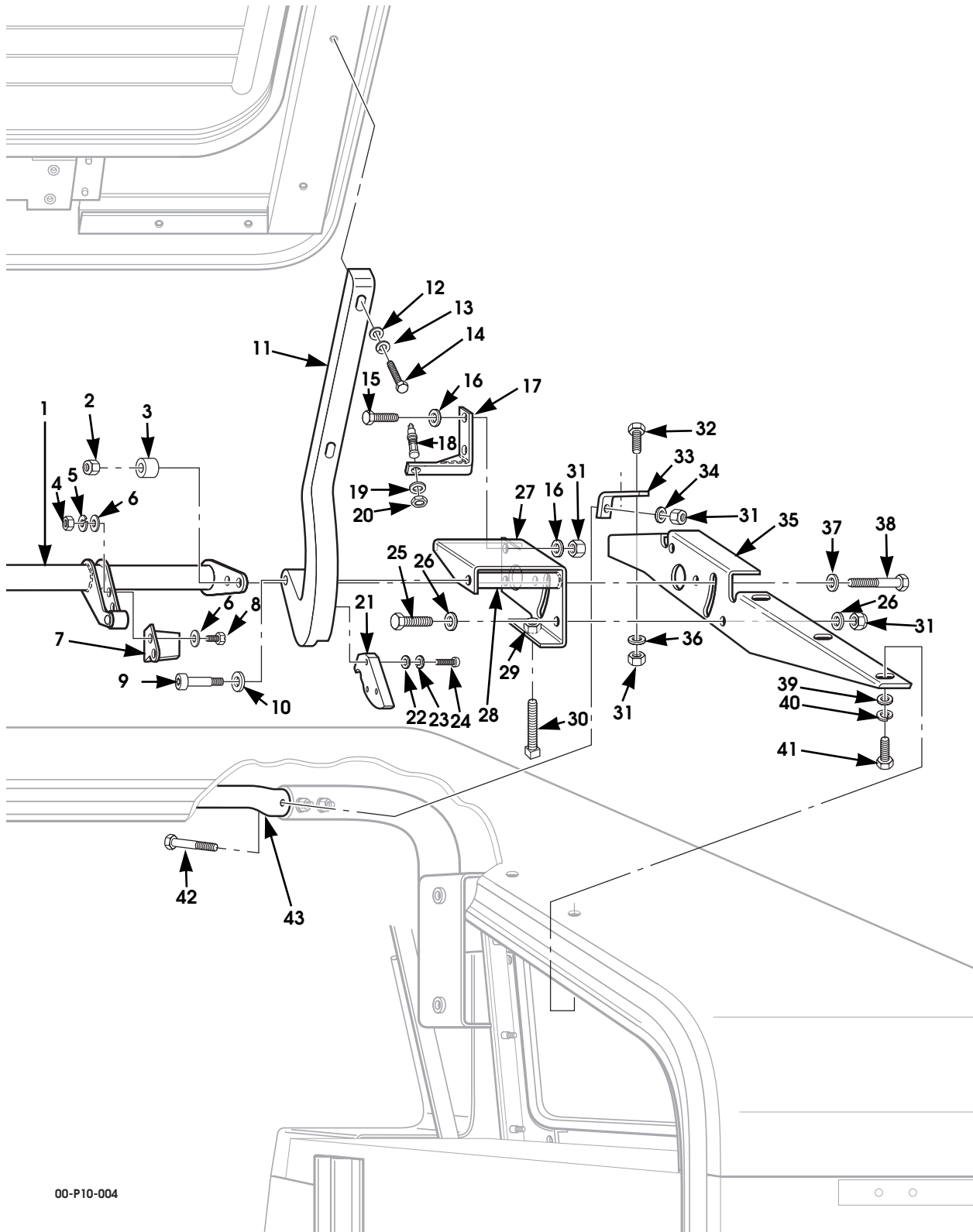

00-P10-004

Figure 10-32. Slant-Back Door Mounting Components And Hinges.

# 2001 HUMMER PARTS CATALOG

**BODY 10-87**

ITEM	PART NUMBER	DESCRIPTION	QTY
		<b>Figure 10-32. Slant-Back Door Mounting Components And Hinges.</b>	
1	6010049	TORSION BAR ASSEMBLY . . . . .	1
2	N/S	NUT, 5/16 - 18 . . . . .	2
3	6010465	GUIDE, center balance tension adjuster . . . . .	2
4	N/S	NUT, #10 - 24 . . . . .	2
5	N/S	LOCKWASHER, #10. . . . .	2
6	N/S	WASHER, flat, #10 . . . . .	4
7	6010693	LEVER, slant-back light switch . . . . .	1
8	N/S	BOLT, #10 - 24 x 3/4 . . . . .	2
9	6011294	BOLT, shoulder . . . . .	2
10	6011292	SPACER . . . . .	2
11	6010047	HINGE DOOR, L.H. . . . .	1
11	6010048	HINGE DOOR, R.H. . . . .	1
12	N/S	WASHER, flat, 3/8 . . . . .	4
13	MS35338 40	LOCKWASHER . . . . .	4
14	N/S	BOLT, 3/8 - 16 x 2 . . . . .	4
15	N/S	BOLT, 3/8 - 16 x 1 1/8 . . . . .	2
16	N/S	WASHER, flat, 3/8 . . . . .	4
17	6011173	BRACKET, slant-back door light switch mounting . . . . .	1
18	5939088	LIGHT SWITCH ASSEMBLY. . . . .	1
19	S.I.A.	•WASHER, light switch . . . . .	1
20	S.I.A.	•NUT, light switch . . . . .	1
21	6010603	DOOR CAM . . . . .	2
22	N/S	WASHER, 1/4. . . . .	4
23	N/S	LOCKWASHER, 1/4. . . . .	4
24	N/S	BOLT, 1/4 - 20 x 1 . . . . .	4
25	N/S	BOLT, 3/8 - 16 x 1 . . . . .	2
26	N/S	WASHER, flat, 3/8 . . . . .	4
27	6010494	BRACKET ASSEMBLY, hinge mounting, L.H. . . . .	1
27	6010496	BRACKET ASSEMBLY, hinge mounting, R.H. . . . .	1
28	6010495	SPACER, hinge bolt . . . . .	2
29	N/S	NUT, 3/8 - 16 . . . . .	2
30	N/S	SPECIAL BOLT, 3/8 - 16 x 2 1/4. . . . .	2
31	MS51943 35	LOCKNUT . . . . .	10
32	N/S	BOLT, 3/8 - 16 x 1 . . . . .	4
33	6010492	SUPPORT, center balance mounting bracket . . . . .	2
34	N/S	WASHER, flat, 3/8 . . . . .	2
35	6010914	BRACKET, mounting, counter balance, slant-back, L.H. . . . .	1
35	6010915	BRACKET, mounting, counter balance, slant-back, R.H. . . . .	1
36	N/S	WASHER, flat, 3/8 . . . . .	4
37	6010466	GUIDE, center balance tension adjuster . . . . .	2



# 2001 HUMMER PARTS CATALOG

## 10-88 BODY

ITEM	PART NUMBER	DESCRIPTION	QTY
		<b>Figure 10-32.</b> <b>Slant-Back Door Mounting Components And Hinges.</b>	
38	6011294	BOLT, shoulder. . . . .	2
39	N/S	WASHER, flat, 3/8 . . . . .	6
40	N/S	LOCKWASHER, 3/8 . . . . .	6
41	N/S	BOLT, 3/8 - 16 x 1. . . . .	6
42	N/S	BOLT, 3/8 - 16 x 3. . . . .	2
43	6010059	C-PILLAR ASSEMBLY, intermediate . . . . .	1



# 2001 HUMMER PARTS CATALOG

## 10-90 BODY

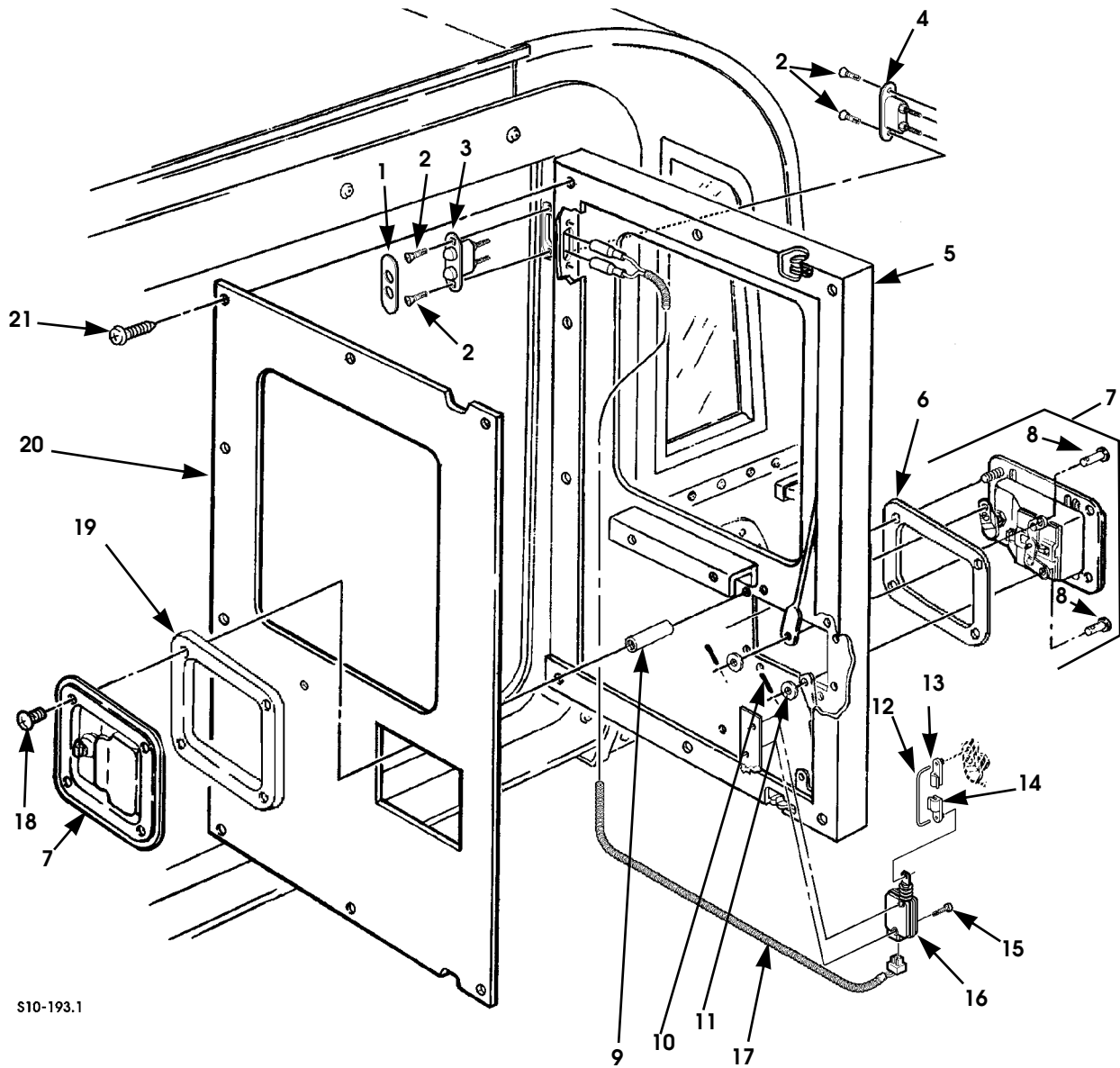

Figure 10-33. Station Wagon Cargo Doors, Power Door Lock.

# 2001 HUMMER PARTS CATALOG

**BODY 10-91**

ITEM	PART NUMBER	DESCRIPTION	QTY
		<b>Figure 10-33. Station Wagon Cargo Doors, Power Door Lock.</b>	
1	6008581	SEAL, door lock switch . . . . .	1
2	N/S	SCREW, flat head, #6 - 32 x 5/8 . . . . .	4
3	6008348	CONTACTS, power door lock, jamb-side . . . . .	1
4	6008347	CONTACTS, power door lock, door-side . . . . .	1
5	6008357P	DOOR ASSEMBLY, cargo, R.H. . . . .	1
6	6000248	GASKET, exterior handle . . . . .	1
7	6009572	HANDLE ASSEMBLY, back-to-back, interior/exterior . . . . .	1
8	S.I.A.	•CONNECTING PIN . . . . .	2
9	S.I.A.	•SPACER . . . . .	4
10	S.I.A.	•COTTER PIN . . . . .	2
11	S.I.A.	•WASHER, flat, 3/16 . . . . .	2
12	6008346	ROD, power lock . . . . .	1
13	6000747	ROD CLIP, interior handle rod . . . . .	5
14	5939037	ROD END CLIP . . . . .	1
15	6006283	SCREW, truss head . . . . .	1
16	6003590	ACTUATOR, power door lock . . . . .	1
17	6008553	HARNESS, power door lock, cargo door . . . . .	1
18	N/S	SCREW, phcr, 1/4 - 20 x 1 . . . . .	4
19	6005633	SPACER, interior handle. . . . .	1
20	6005668P	DOOR PANEL, interior, R.H. . . . .	1
21	6006283	SCREW . . . . .	8
	6009165	MODULE, power lock, vertical door (not illustrated) . . . . .	1
	6010117	HARNESS ASSEMBLY, lock module, vertical door (not illustrated) . . . . .	1

# 2001 HUMMER PARTS CATALOG

## 10-92 BODY

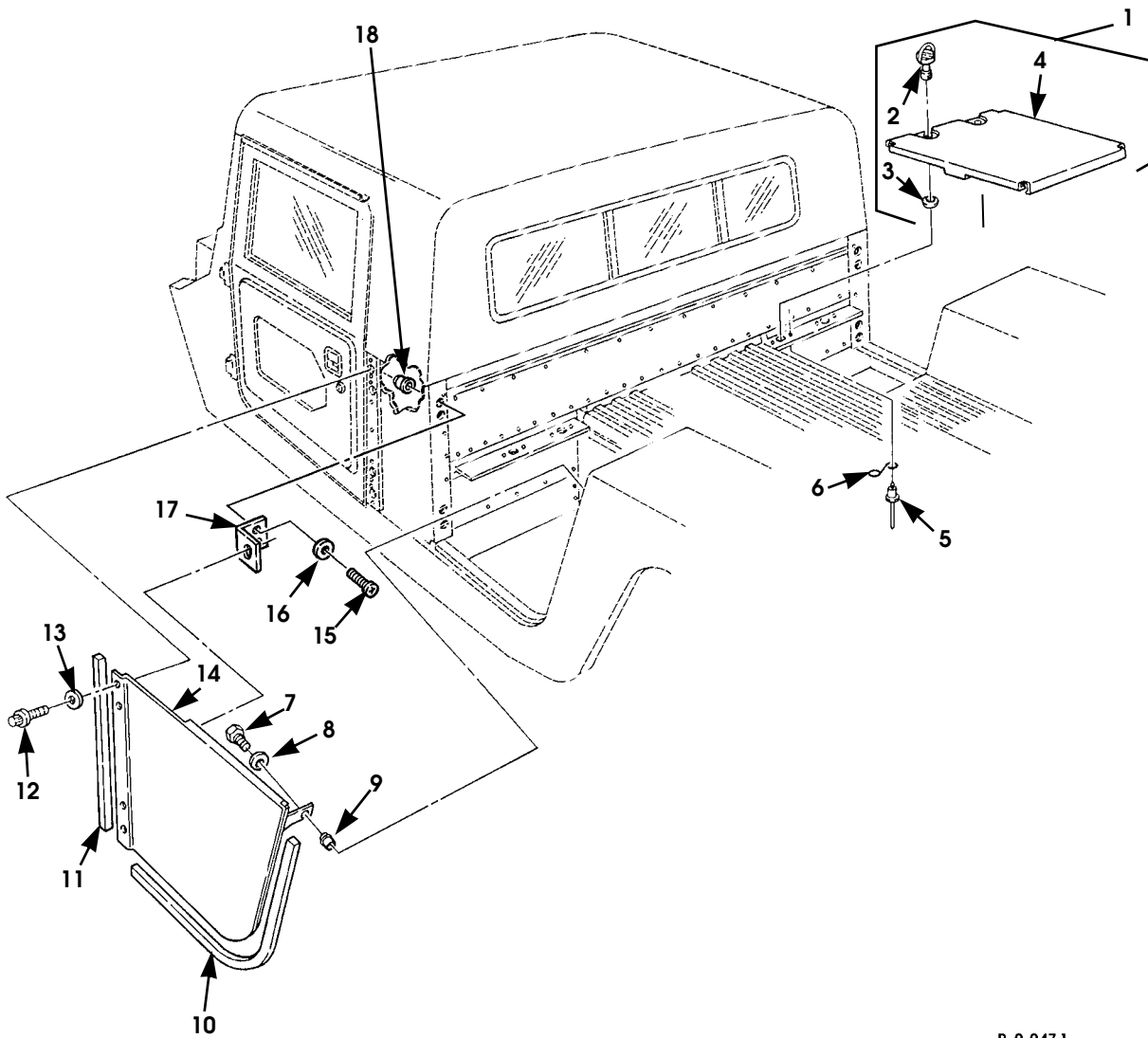

P 0-047.1

Figure 10-34. Fixed Door, Footwell Cover, and Related Parts, Two-Passenger Enlarged Cab, Model 89.

# 2001 HUMMER PARTS CATALOG

**BODY 10-93**

ITEM	PART NUMBER	DESCRIPTION	QTY
		<b>Figure 10-34. Fixed Door, Footwell Cover, and Related Parts, Two-Passenger Enlarged Cab, Model 89.</b>	
1	6004513P	COVER ASSEMBLY, footwell . . . . .	2
2	12339738 3	•STUD, ring head . . . . .	2
3	12341011	•RING RETAINER. . . . .	2
4	S.I.A.	•COVER, footwell . . . . .	2
5	M24243/1A405	RIVET . . . . .	8
6	12338823	RECEPTACLE, spring . . . . .	4
7	N/S	BOLT, 1/4 - 20 x 5/8, Gr5, CAD . . . . .	2
8	N/S	WASHER, flat, 1/4, CAD . . . . .	2
9	5937584	NUT INSERT . . . . .	2
10	12339419 2	SEAL, fixed door, 22", SEE NOTE 1 . . . . .	2
11	12339419 1	SEAL, fixed door, 50", SEE NOTE 1 . . . . .	2
12	5939423P2	BOLT . . . . .	8
13	5939634P2	WASHER, flat, hinge mounting . . . . .	8
14	6004506P	DOOR ASSEMBLY, L.H., fixed . . . . .	1
14	6004507P	DOOR ASSEMBLY, R.H. , fixed. . . . .	1
15	N/S	SCREW, #10 - 24 x 7/8 . . . . .	8
16	N/S	WASHER, flat, #10, CAD . . . . .	8
17	6005528	BRACKET, fixed door . . . . .	4
18	6001566	NUT, insert, #10 - 24. . . . .	8

# 2001 HUMMER PARTS CATALOG

10-94 BODY

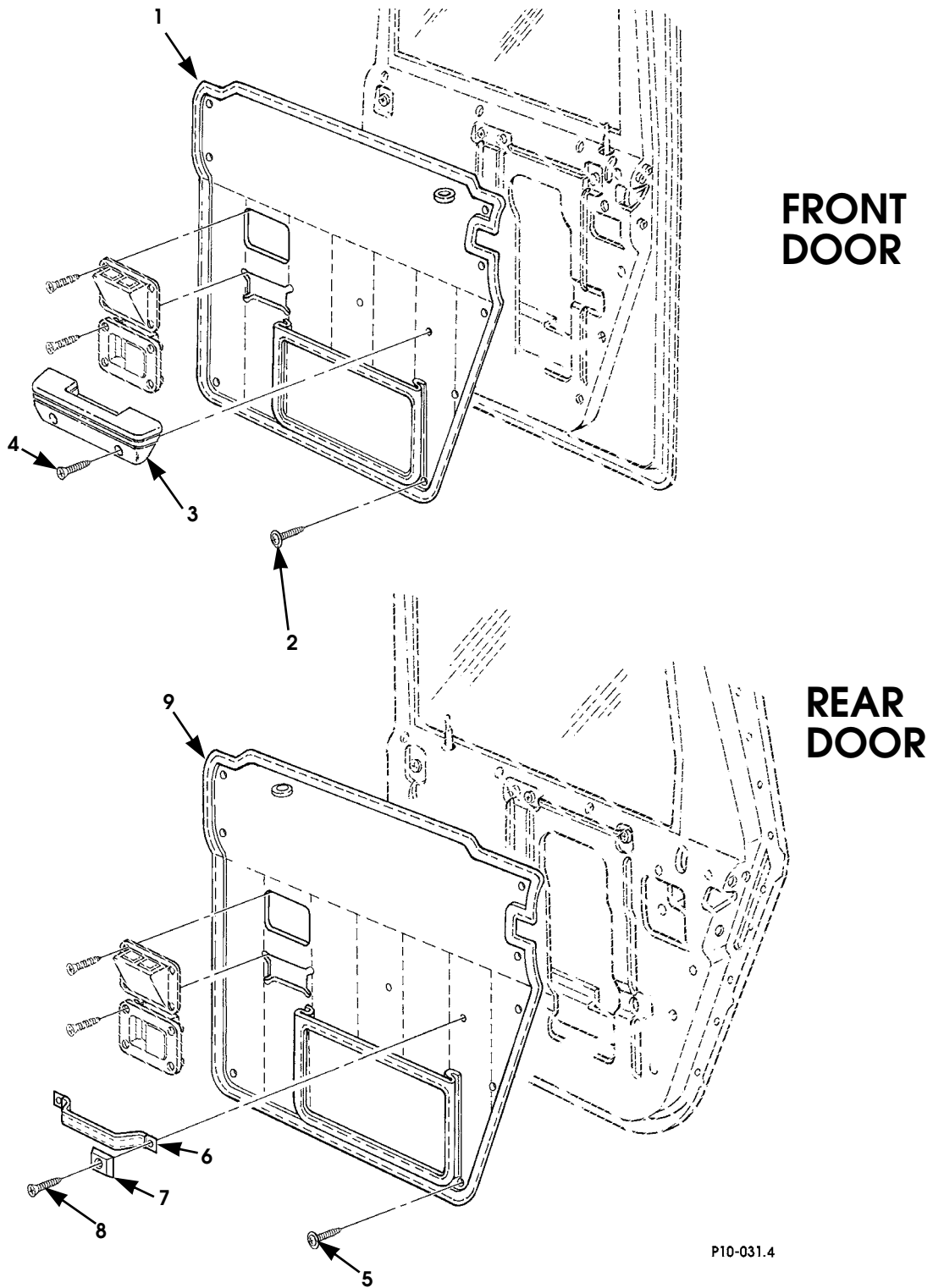

P10-031.4

Figure 10-35. Panel Assembly Door Trim.

# 2001 HUMMER PARTS CATALOG

**BODY 10-95**

ITEM	PART NUMBER	DESCRIPTION	QTY
		<b>Figure 10-35. Panel Assembly Door Trim.</b>	
1	6004462G	PANEL ASSEMBLY, L.H., deluxe front door trim, gray . . .	1
1	6004462	PANEL ASSEMBLY, L.H., deluxe front door trim, tan . . . .	1
1	6004460G	PANEL ASSEMBLY, L.H., deluxe front door trim, gray, manual windows . . . . .	1
		83, 84, 89	
1	6004463G	PANEL ASSEMBLY, R.H., deluxe front door trim, gray . . .	1
1	6004463	PANEL ASSEMBLY, R.H., deluxe front door trim, tan . . . .	1
1	6004461G	PANEL ASSEMBLY, R.H., deluxe front door trim, gray, manual windows . . . . .	1
		83, 84, 89	
2	6000243G	TRIM SCREW, 3/4, gray, front door panel. . . . .	16
2	6000243	TRIM SCREW, 3/4, tan, front door panel . . . . .	16
3	6011393G	ARMREST ASSEMBLY, front, gray . . . . .	2
3	6011393	ARMREST ASSEMBLY, front, tan . . . . .	2
4	N/S	SCREW, phcr, 1/4 - 20 x 1 3/4 . . . . .	4
5	6000243G	SCREW/WASHER ASSEMBLY, rear door panel, gray. . . .	16
		83, 84, 90, 91	
5	6000243	SCREW/WASHER ASSEMBLY, rear door panel, tan. . . . .	16
		83, 84, 90, 91	
6	6001013G	PULL HANDLE ASSEMBLY, rear door, gray . . . . .	2
		83, 84, 90, 91	
6	6001013	PULL HANDLE ASSEMBLY, rear door, tan . . . . .	2
		83, 84, 90, 91	
7	6000400	CAP ASSEMBLY, rear door pull handle screw . . . . .	4
		83, 84, 90, 91	
8	N/S	SCREW, oval head, #8 - 32 x 1, rear door pull handle .	4
		83, 84, 90, 91	
9	6002462G	PANEL ASSEMBLY, L.H., deluxe rear door trim, gray . . .	1
		83, 84, 90, 91	
9	6002462	PANEL ASSEMBLY, L.H., deluxe rear door trim, tan. . . . .	1
		83, 84, 90, 91	
9	6002464G	PANEL ASSEMBLY, R.H., deluxe rear door trim, gray . . .	1
		83, 84, 90, 91	
9	6002464	PANEL ASSEMBLY, R.H., deluxe rear door trim, tan . . . .	1
		83, 84, 90, 91	



# 2001 HUMMER PARTS CATALOG

10-96 BODY

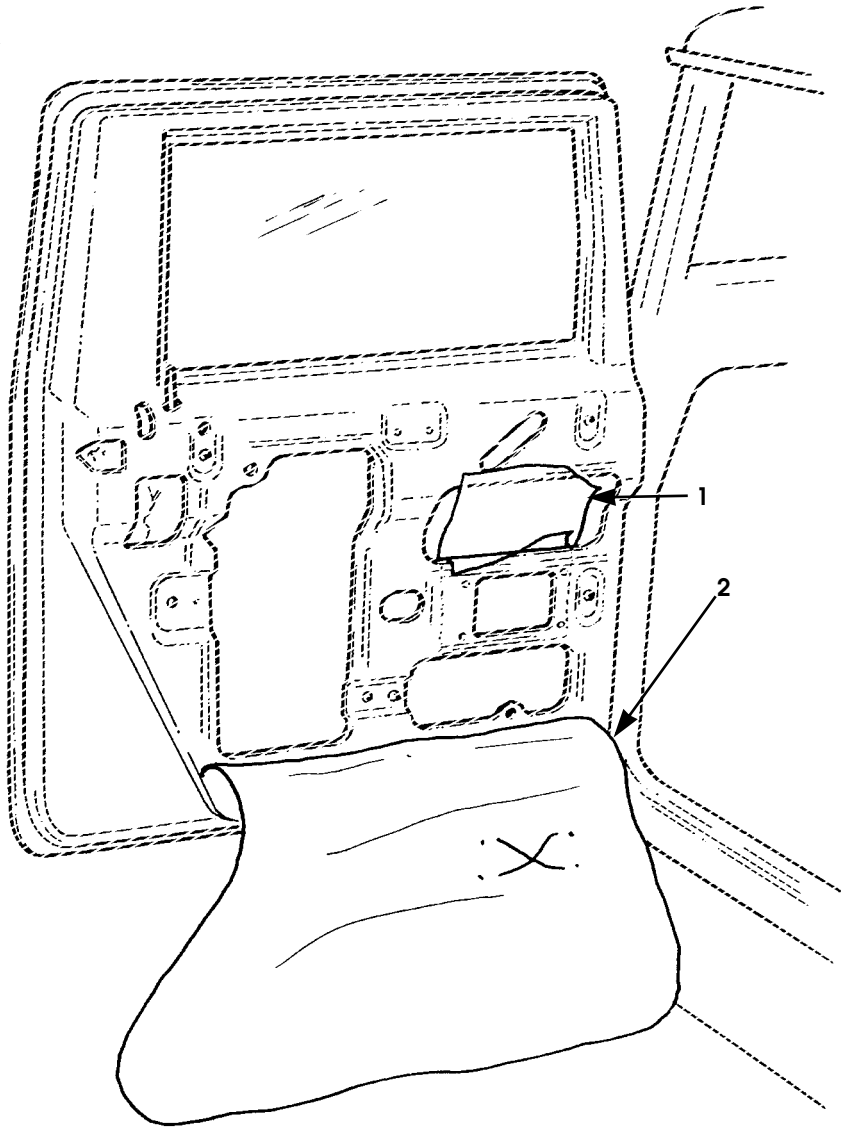

P12-053

Figure 10-36. Weathershield, Doors.

# 2001 HUMMER PARTS CATALOG

**BODY 10-97**

ITEM	PART NUMBER	DESCRIPTION	QTY
		<b>Figure 10-36. Weathershield, Doors.</b>	
1	6001694	WATERSHIELD, door latch 89 .....	2
1	6001694	WATERSHIELD, door latch 83, 84, 90, 91 .....	4
2	6001623	WATERSHIELD, front, L.H. ....	1
2	6001624	WATERSHIELD, front, R.H. ....	1
2	6001625	WATERSHIELD, rear, L.H. 83, 84, 90, 91 .....	1
2	6001626	WATERSHIELD, rear, R.H. 83, 84, 90, 91 .....	1



# 2001 HUMMER PARTS CATALOG

BODY 10-99

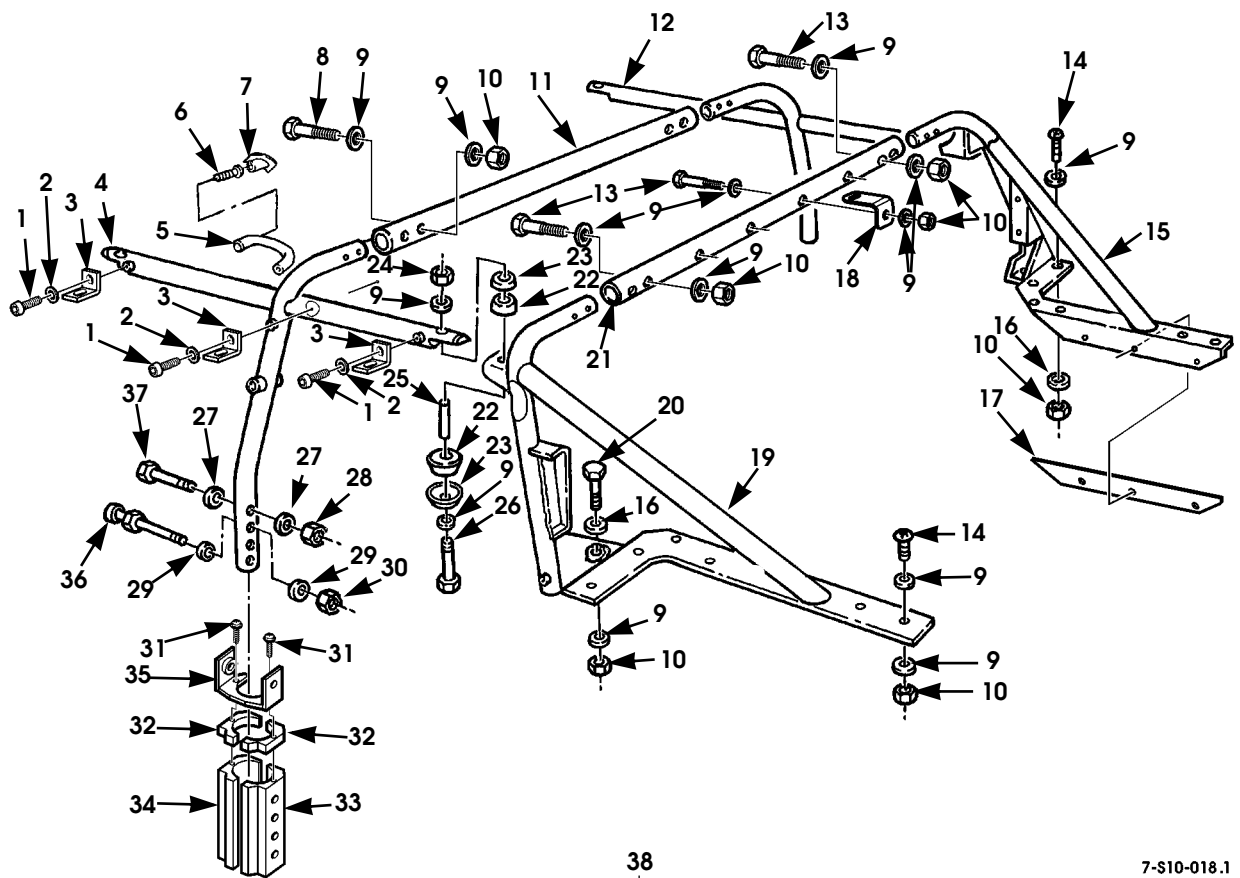

7-S10-018.1

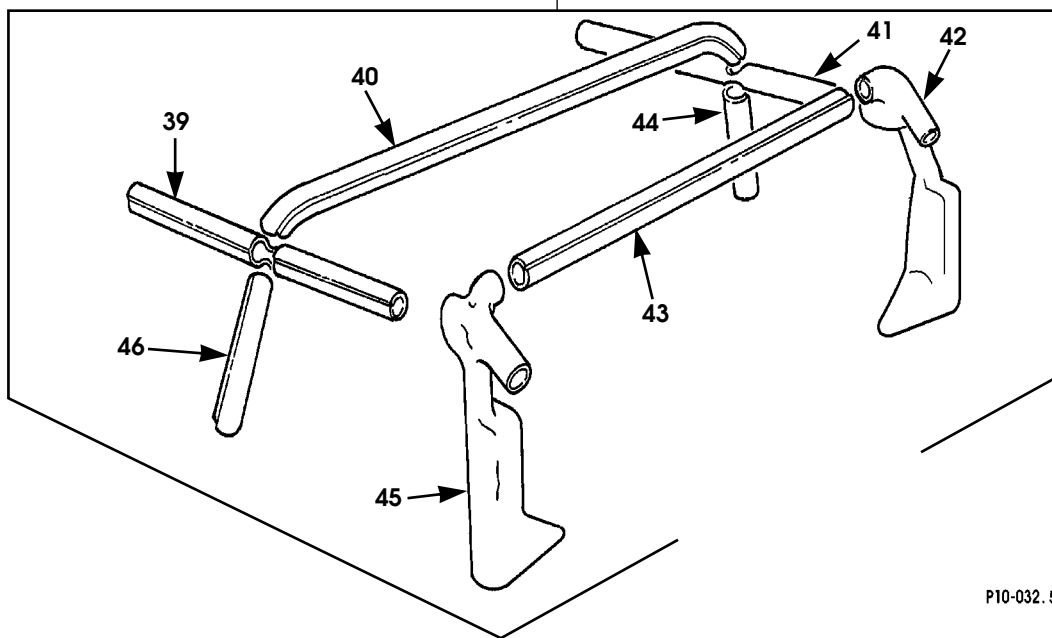

P10-032.5

Figure 10-37. Soft Top Support Structure, Model 90  
(Sheet 1 of 2).

AM General Corporation

5745278

# 2001 HUMMER PARTS CATALOG

## 10-100 BODY

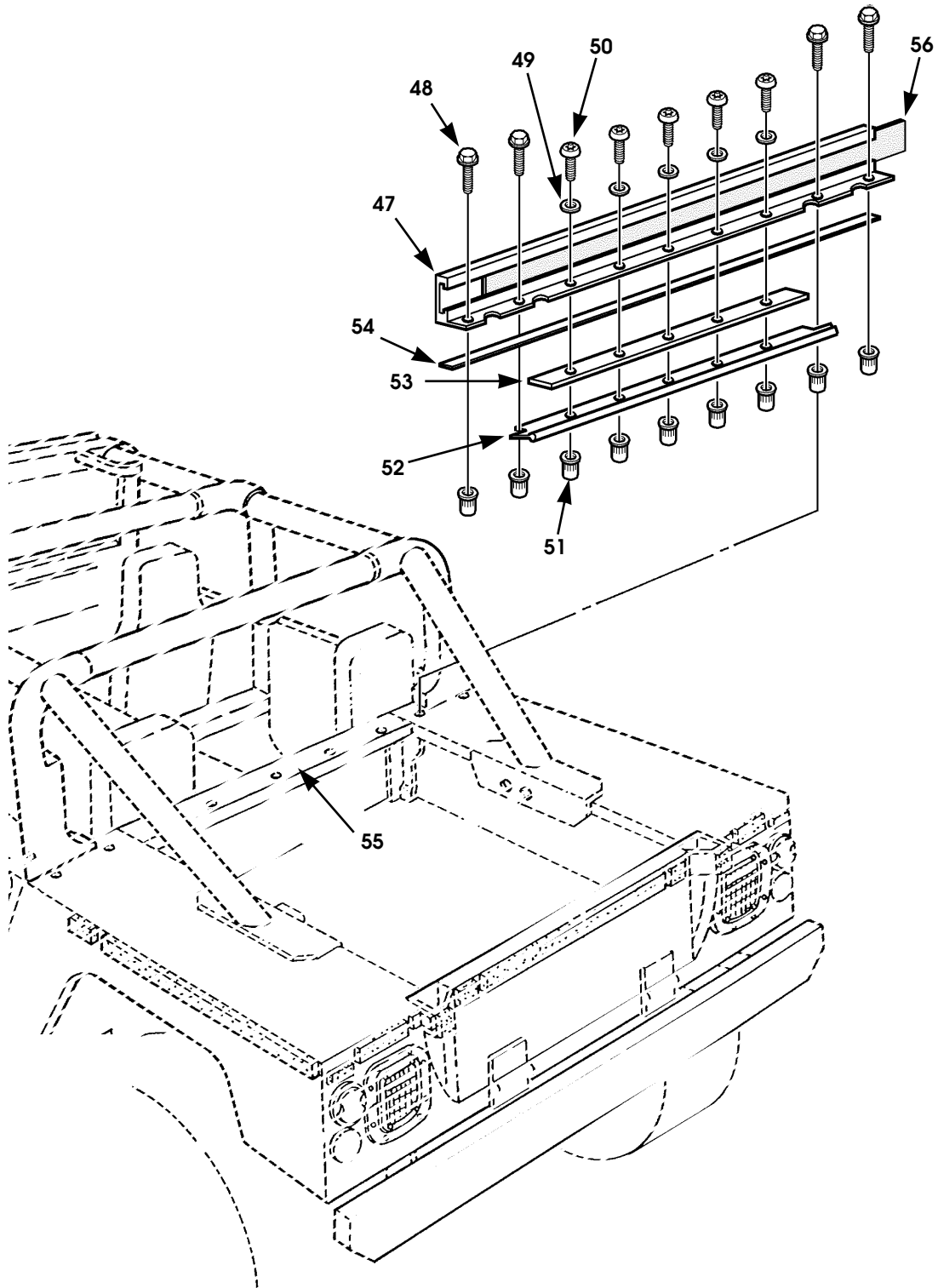

P10-114

Figure 10-37. Soft Top Support Structure, Model 90  
(Sheet 2 of 2)

# 2001 HUMMER PARTS CATALOG

**BODY 10-101**

ITEM	PART NUMBER	DESCRIPTION	QTY
		<b>Figure 10-37. Soft Top Support Structure, Model 90</b>	
1	6009752	SCREW, hex socket head, flanged . . . . .	6
2	N/S	WASHER, flat, #10 . . . . .	6
3	6009705	BRACKET, H-rail . . . . .	6
4	6009560	SUPPORT ASSEMBLY, soft top, side, L.H. . . . .	1
5	5939469G	HANDLE, grab, gray . . . . .	4
5	5939469	HANDLE, grab, tan . . . . .	4
6	N/S	SCREW, phcr, 1/4 - 20 x 3/4, CAD . . . . .	8
7	6000027G	PLUG, grab handle, gray . . . . .	8
7	6000027	PLUG, grab handle, tan . . . . .	8
8	N/S	SCREW, 3/8 - 16 x 2 3/4, Gr8, CAD . . . . .	4
9	N/S	WASHER, flat, 3/8, type B, hard . . . . .	66
10	N/S	LOCKNUT, 3/8 - 16, Gr8 . . . . .	32
11	6009493	SUPPORT BAR, center . . . . .	1
12	6009561	SUPPORT ASSEMBLY, soft top, side, R.H. . . . .	1
13	N/S	BOLT, 3/8 - 16 x 3 1/4, Gr 8, CAD . . . . .	8
14	N/S	SCREW, 3/8 - 16 x 1 . . . . .	20
15	6009563	SUPPORT ASSEMBLY, C-pillar, rear, R.H. . . . .	1
16	12340880	WASHER, flat, 7/16" x 1 3/16" . . . . .	8
17	6000119B2	SPACER, C-pillar support assembly, side . . . . .	6
18	6009736	BRACKET, tensioning strap . . . . .	5
19	6009562	SUPPORT ASSEMBLY, C-pillar, rear, L.H. . . . .	1
20	N/S	BOLT, 3/8 - 16 x 1 1/2, Gr8, CAD . . . . .	4
21	6009727	SUPPORT BAR, center . . . . .	1
22	12339571	RUBBER MOUNT, roof (SEE NOTE 1) . . . . .	8
23	12339561	PLATE, snubber (SEE NOTE 1) . . . . .	8
24	N/S	LOCKNUT, low profile, 3/8 - 16 (SEE NOTE 1) . . . . .	4
25	12338186 52	SPACER, C-pillar mount (SEE NOTE 1). . . . .	4
26	N/S	BOLT, 3/8 - 16 x 3 1/2, Gr8, CAD (SEE NOTE 1). . . . .	4
27	12339724	WASHER, flat, hardened . . . . .	12
28	N/S	LOCKNUT, 5/16 - 24, Gr8 . . . . .	6
29	N/S	WASHER, flat, hard, 1/2, type B . . . . .	4
30	N/S	LOCKNUT, 1/2 - 20, Gr8 . . . . .	2
31	N/S	SCREW, tapping, phcr, #10 - 32 x 7/8 . . . . .	4
32	6005156	SEAL, B-pillar . . . . .	4
33	6005459	CONNECTION BLOCK, R.H. front/L.H. rear . . . . .	2
34	6005458	CONNECTION BLOCK, L.H. front/R.H. rear . . . . .	2
35	6004541	BRACKET, B-pillar cover mounting . . . . .	2
36	6000392P2	STRIKER, door . . . . .	2
37	N/S	BOLT, 5/16 - 24 x 4.21" . . . . .	6

# 2001 HUMMER PARTS CATALOG

## 10-102 BODY

ITEM	PART NUMBER	DESCRIPTION	QTY
		<b>Figure 10-37.</b> <b>Soft Top Support Structure, Model 90 (Cont'd)</b>	
38	6009724	BOLSTER COVER KIT, black. . . . .	1
39	S.I.K.	•COVER, horizontal rail, L.H., black. . . . .	1
40	S.I.K.	•COVER, B-pillar, center, black . . . . .	1
41	S.I.K.	•COVER, horizontal rail, R.H., black . . . . .	1
42	S.I.K.	•COVER, C-pillar, vertical, R.H., black . . . . .	1
43	S.I.K.	•COVER, C-pillar, center, black . . . . .	1
44	S.I.K.	•COVER, B-pillar, vertical, R.H., black . . . . .	1
45	S.I.K.	•COVER, C-pillar, vertical, L.H., black . . . . .	1
46	S.I.K.	•COVER, B-pillar, vertical, L.H., black . . . . .	1
47	6001658	EXTRUSION, rear curtain tonneau . . . . .	1
48	6000114P2	TRIM SCREW, 3/4. . . . .	4
49	S.I.K.	LOCKWASHER, split, 1/4, black . . . . .	5
50	N/S	BOLT, buttonhead Torx, 1/4 - 20 x 1. . . . .	5
51	5937584	NUT INSERT, 1/4 - 20 . . . . .	9
52	6008387	SEAL, rear, roof-to-bulkhead . . . . .	1
53	6003416	SPACER, bulkhead, J-rail . . . . .	1
54	6001276	SEAL, outer window frame . . . . .	1
55	5745011	TAPE, foam core, Butyl, 14' long, SEE NOTES 2 AND 3 .	1
56	5745080	VELCRO STRIP, rear toneau curtain . . . . .	1
		NOTE 1: QUANTITIES INCLUDE A-PILLAR ROOF MOUNTING HARDWARE ALSO	
		NOTE 2: CUT FROM 720' BULK ROLL, BUTYL FOAM CORE TAPE, P/N 6008053.	
		NOTE 3: CUT 5' OF TAPE P/N 5745011 FOR THE TOP STRIP ABOVE BULKHEAD; CUT 8 1/2' OF TAPE P/N 5745011 FOR THE BOTTOM STRIP ABOVE BULKHEAD.	





# 2001 HUMMER PARTS CATALOG

## 10-104 BODY

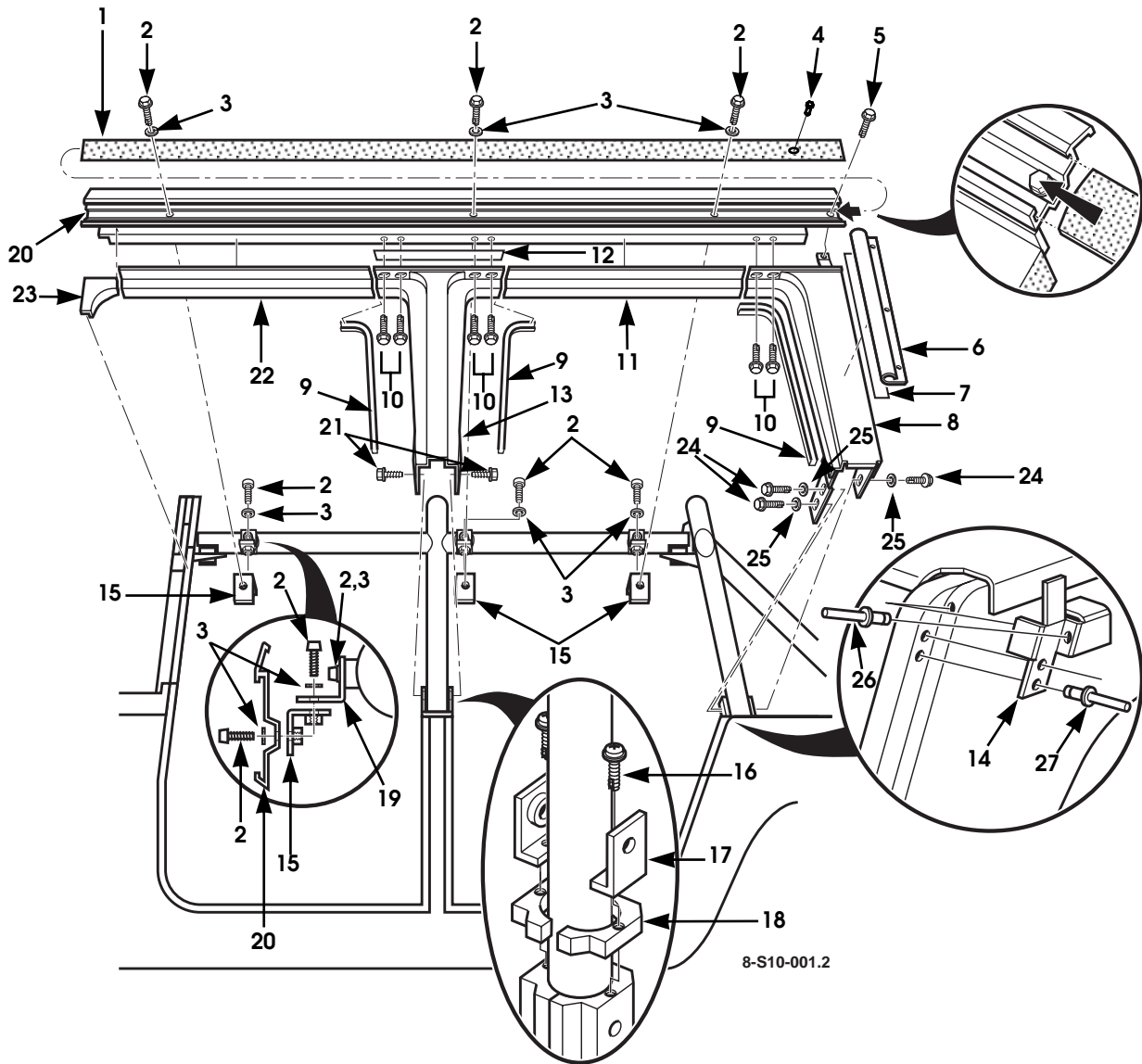

Figure 10-38. Support Structure, Soft Top, Model 90

# 2001 HUMMER PARTS CATALOG

**BODY 10-105**

ITEM	PART NUMBER	DESCRIPTION	QTY
		<b>Figure 10-38. Support Structure, Soft Top, Model 90</b>	
1	6009801	VELCRO STRIP, hook part, L.H. . . . .	1
1	6009802	VELCRO STRIP, hook part, R.H. . . . .	1
2	6009752	BOLT, hex socket . . . . .	24
3	N/S	WASHER, flat, 1/4 . . . . .	24
4	N/S	SCREW, tapping, #8 - 32 x 3/8. . . . .	2
5	N/S	SCREW, tapping, 1/4 - 20 x 1/2 . . . . .	2
6	6009710	EXTRUSION, C-pillar cover retainer, L.H. . . . .	1
6	6009726	EXTRUSION, C-pillar cover retainer, R.H. . . . .	1
7	6009857	FOAM TAPE, extrusion to C-pillar cover. . . . .	2
8	6009740	C-PILLAR COVER ASSEMBLY, L.H. . . . .	1
8	6009741	C-PILLAR COVER ASSEMBLY, R.H. . . . .	1
9	N/S	EDGE GUARD, 18", B-pillar, front and rear, and C-pillar, front, SEE NOTE 1 . . . . .	6
10	N/S	SCREW, tapping, phcr, #8 - 32 x 3/8 . . . . .	12
11	6009789	FILLER PANEL, plastic, B-pillar-to-C-pillar. . . . .	2
12	NPN	SEALING TAPE, B-pillar cover-to-H-rail, 10" long SEE NOTE 2. . . . .	2
13	6009585	B-PILLAR COVER. . . . .	2
14	6005456	FILLER PANEL, L.H. . . . .	1
14	6005457	FILLER PANEL, R.H. . . . .	1
15	6009738	BRACKET, H-rail . . . . .	6
16	N/S	SCREW, tapping, #10 - 24 x 7/8. . . . .	4
17	6004541	MOUNTING, B-Pillar cover . . . . .	2
18	6005156	SEAL, B-Pillar. . . . .	4
19	6009705	STANDOFF BRACKET, H-rail . . . . .	6
20	6009703	H-RAIL, LH . . . . .	1
20	6009704	H-RAIL, RH . . . . .	1
21	N/S	BOLT, 5/16-18 x 5/8. . . . .	4
22	6009788	FILLER PANEL, plastic, windshield-to-B-pillar. . . . .	2
23	6009735	CLOSEOUT PANEL, roof-to-windshield . . . . .	2
24	N/S	BOLT, 1/4 - 20 x 3/4, C-pillar. . . . .	6
25	N/S	LOCKWASHER, 1/4, C-pillar . . . . .	6
26	N/S	RIVET, countersunk, 1/8 . . . . .	2
27	N/S	RIVET, 1/8. . . . .	4
		NOTE 1: CUT FROM 24" EDGE GUARD 5745010.	
		NOTE 2: CUT TO LENGTH FROM BULK SEALING TAPE, P/N 6006217, 150-FT ROLL.	

# 2001 HUMMER PARTS CATALOG

## 10-106 BODY

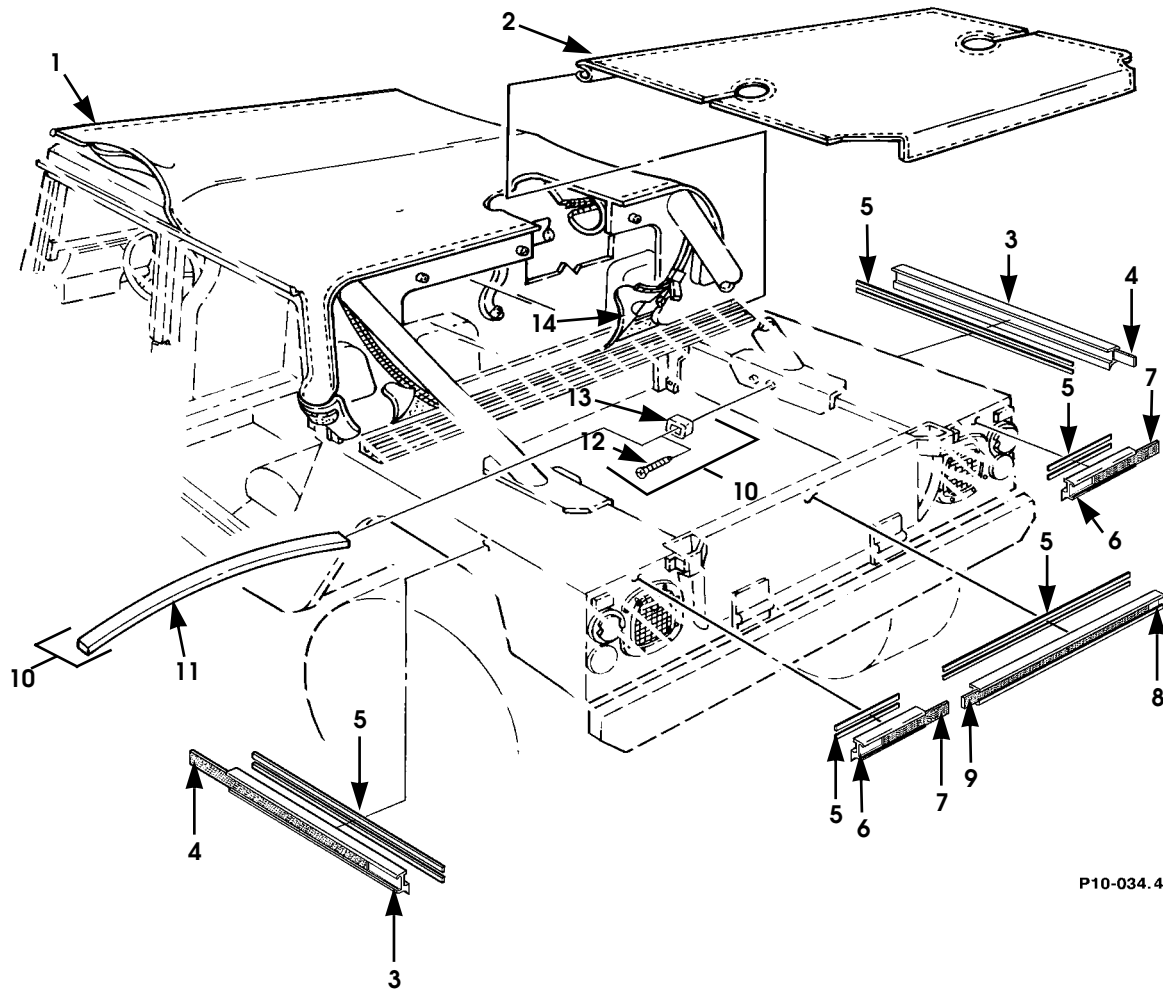

P10-034.4

Figure 10-39. Four-Door Soft Top Kit, Basic, Model 90.

# 2001 HUMMER PARTS CATALOG

**BODY 10-107**

ITEM	PART NUMBER	DESCRIPTION	QTY
		<b>Figure 10-39.</b> <b>Four-Door Soft Top Kit, Basic, Model 90.</b>	
1	6009720	TOP ASSEMBLY, black. . . . .	1
1	6009721	TOP ASSEMBLY, tan. . . . .	1
2	6009722	COVER ASSEMBLY, tonneau, black. . . . .	1
2	6009723	COVER ASSEMBLY, tonneau, tan . . . . .	1
3	6001670	PVC EXTRUSION, tonneau. . . . .	2
		83, 90	
4	5745081	•VELCRO STRIP, 41 inch . . . . .	2
		83, 90	
5	N/S	•ADHESIVE TAPE, double sided, cut to length . . . . .	5
6	6001671	PVC EXTRUSION, tonneau. . . . .	2
		83, 90	
7	5745083	•VELCRO STRIP, 9 inch . . . . .	2
		83, 90	
8	6001669	PVC EXTRUSION, tonneau. . . . .	1
		83, 90	
9	5745082	•VELCRO STRIP, 43 inch . . . . .	1
		83, 90	
10	5742965	KIT, tonneau bow assembly . . . . .	1
		90	
11	S.I.K.	•BOW, wooden . . . . .	2
		90	
12	S.I.K.	•SCREW, #10 - 32 x 3/8 . . . . .	4
		90	
13	S.I.K.	•BRACKET, tonneau cover bow. . . . .	2
		90	
14	5745359	•REAR WINDOW CURTAIN, tan. . . . .	1
14	5745360	•REAR WINDOW CURTAIN, black. . . . .	1

# 2001 HUMMER PARTS CATALOG

## 10-108 BODY

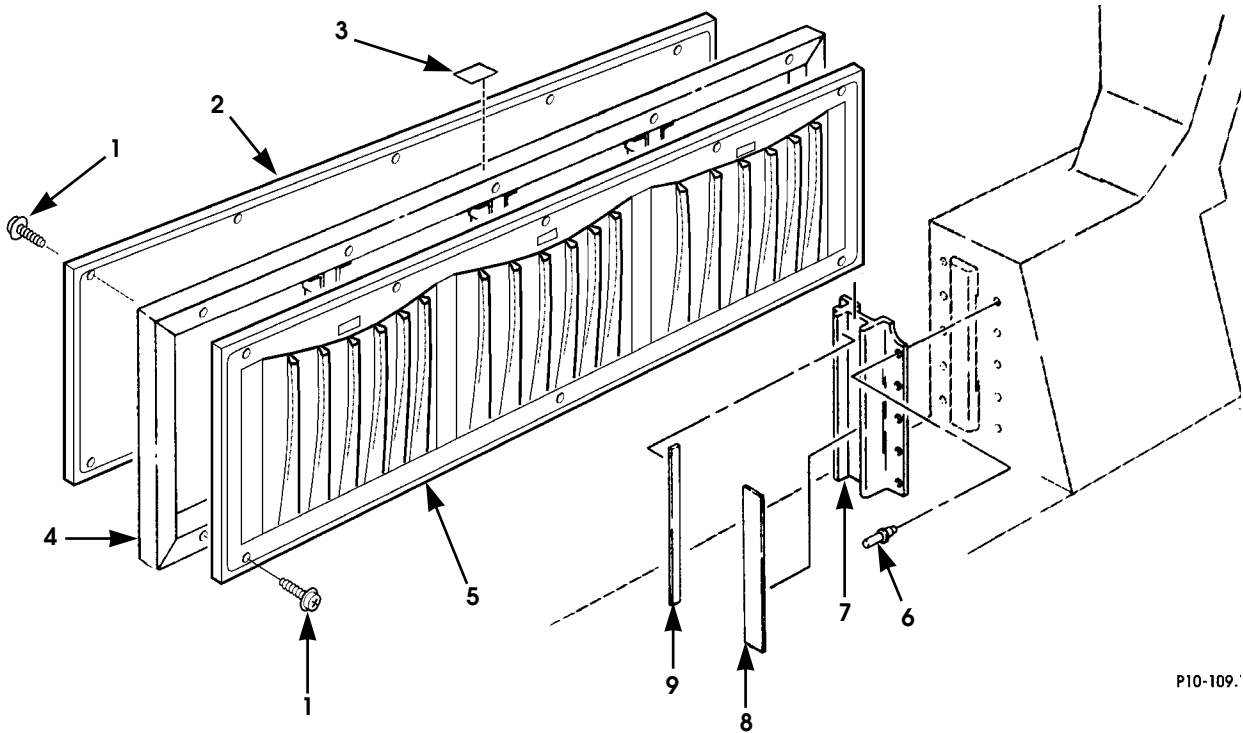

P10-109.

Figure 10-40. Removable Load Barrier, Station Wagon, Model 84

# 2001 HUMMER PARTS CATALOG

**BODY 10-109**

ITEM	PART NUMBER	DESCRIPTION	QTY
		<b>Figure 10-40. Removable Load Barrier, Station Wagon, Model 84</b>	
1	6002686G	TRIM SCREW, 3/4, gray . . . . .	18
1	6002686	TRIM SCREW, 3/4, tan . . . . .	18
2	6002998G	CARPET, load barrier, gray . . . . .	1
2	6002998	CARPET, load barrier, tan . . . . .	1
3	6004009	DECAL, load barrier warning . . . . .	1
4	6002978	FRAME ASSEMBLY, load barrier . . . . .	1
5	6006609G	POCKET ASM., load barrier, gray . . . . .	1
5	6006609	POCKET ASM., load barrier, tan . . . . .	1
6	12339355 1	RIVET, blind, huck . . . . .	20
7	6003014	BRACKET, L.H., load bar . . . . .	1
7	6003020	BRACKET, R.H., load bar . . . . .	1
8	6003015	BUMPER STRIP, center . . . . .	1
9	6007112	BUMPER STRIP, side . . . . .	4

# 2001 HUMMER PARTS CATALOG

## 10-110 BODY

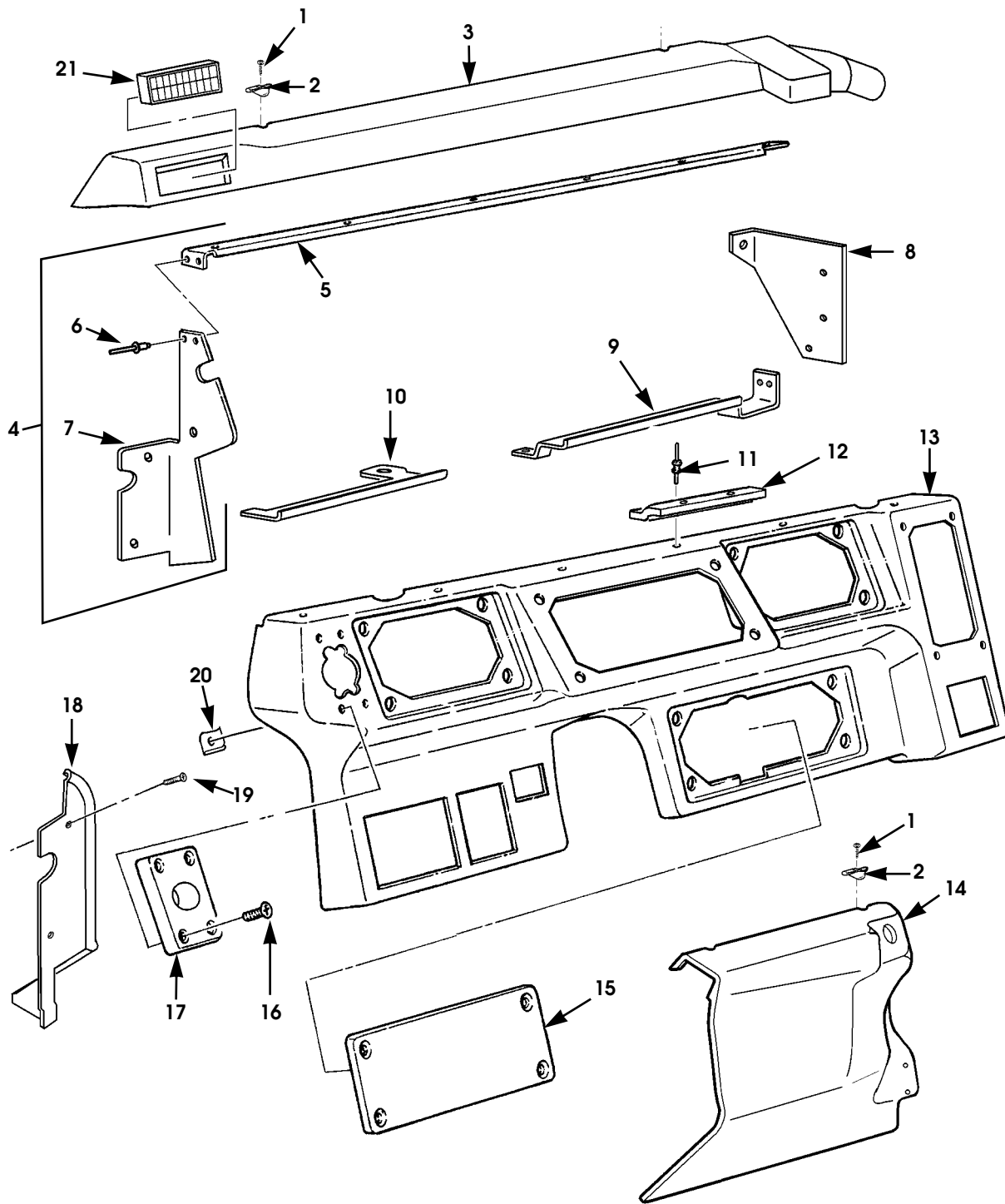

P10-036.8

Figure 10-41. Instrument Panel Assembly, Dash Trim, Crash Pad, and Mounting Hardware.

# 2001 HUMMER PARTS CATALOG

**BODY 10-111**

ITEM	PART NUMBER	DESCRIPTION	QTY
		<b>Figure 10-41. Instrument Panel Assembly, Dash Trim, Crash Pad, and Mounting Hardware.</b>	
1	N/S	SCREW AND WASHER ASSEMBLY, #8-18 x 1" . . . . .	2
2	6010765G	GROMMET, trim, mounting, gray . . . . .	4
2	6010765	GROMMET, trim, mounting, tan . . . . .	4
3	6007054G	CRASH PAD, L.H., deluxe, gray . . . . .	1
3	6007054	CRASH PAD, L.H., deluxe, tan . . . . .	1
4	6007064	BRACKET ASSEMBLY, instrument panel mounting . . . . .	1
5	6007335	•BRACKET, instrument panel support, upper . . . . .	1
6	12339355 1	•RIVET . . . . .	2
7	6006974	•BRACKET, instrument panel support, L.H. . . . .	1
8	6007415	BRACKET, instrument panel support, R.H. . . . .	1
9	5939272	BRACKET, instrument panel support, lower . . . . .	1
10	6007416	BRACKET, instrument panel support, lower, L.H. . . . .	1
11	N/S	RIVET, blind, 3/16" . . . . .	4
12	6007192	BRACKET, instrument panel crash pad mounting . . . . .	2
13	6011487	PANEL, instrument . . . . .	1
14	6010886G	CRASH PAD, R.H., gray . . . . .	1
14	6010886	CRASH PAD, R.H., tan . . . . .	1
15	5939270	PANEL, gauge, lower (blank) . . . . .	1
16	156770	SCREW, oval head . . . . .	4
17	6003558	NOZZLE, defroster, side window . . . . .	1
18	6006289	PANEL, closeout, instrument panel . . . . .	1
19	6005624G	TRIM SCREW, 3/4, gray . . . . .	2
19	6005624	TRIM SCREW, 3/4, tan . . . . .	2
20	12341352	J-NUT, defroster mounting . . . . .	4
21	6007156	LOUVER, crash pad . . . . .	1



# 2001 HUMMER PARTS CATALOG

## 10-112 BODY

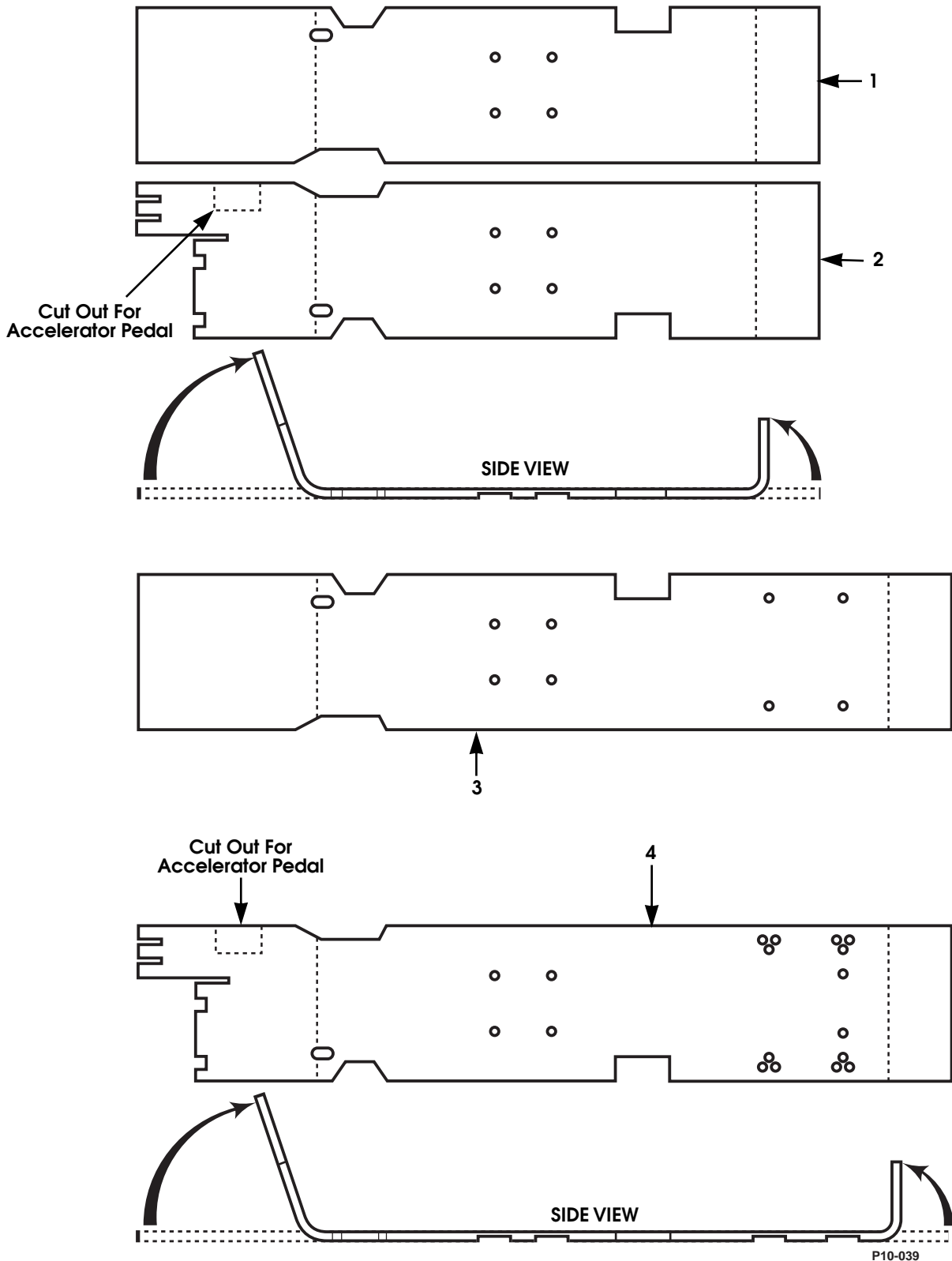

Figure 10-42. Floor Padding, Front and Rear.

# 2001 HUMMER PARTS CATALOG

**BODY 10-113**

ITEM	PART NUMBER	DESCRIPTION	QTY
		<b>Figure 10-42. Floor Padding, Front and Rear.</b>	
1	6009530G	PAD ASSEMBLY, R.H., gray . . . . . 89	1
2	6004547G	PAD ASSEMBLY, L.H., gray . . . . . 89	1
3	6009529G	PAD ASSEMBLY, R.H., gray . . . . . 83, 84, 90	1
3	6009529	PAD ASSEMBLY, R.H., tan . . . . . 83, 84, 90	1
4	6009861G	PAD ASSEMBLY, L.H., gray . . . . . 83, 84, 90	1
4	6009861	PAD ASSEMBLY, L.H., tan . . . . . 83, 84, 90	1

# 2001 HUMMER PARTS CATALOG

## 10-114 BODY

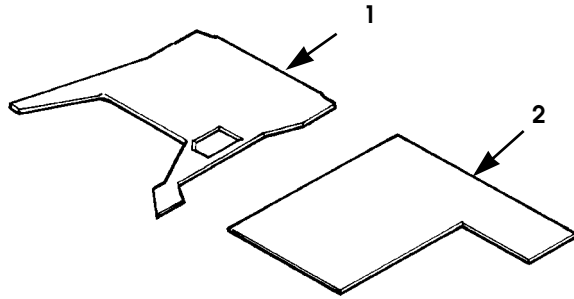

TWO-DOOR CAB

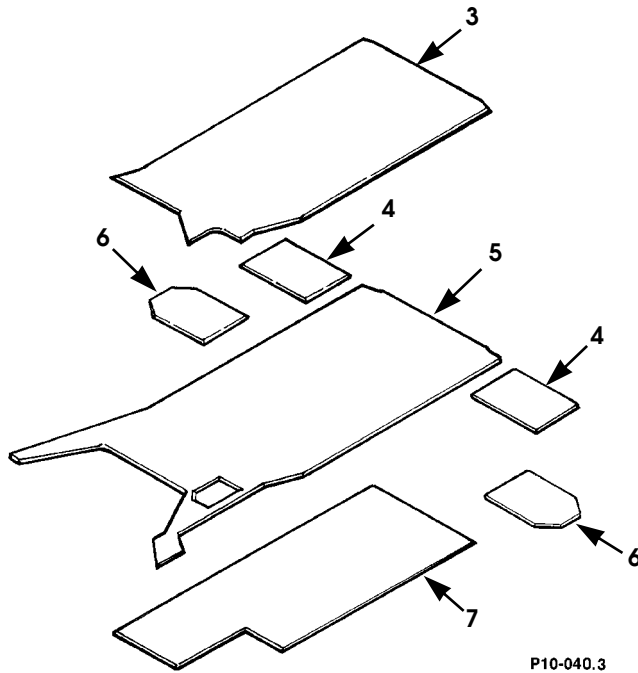

P10-040.3

FOUR-DOOR CAB

Figure 10-43. Interior Tunnel Padding, Carpet, and Hardboard.

# 2001 HUMMER PARTS CATALOG

**BODY 10-115**

ITEM	PART NUMBER	DESCRIPTION	QTY
		<b>Figure 10-43. Interior Tunnel Padding, Carpet, and Hardboard.</b>	
1	6007220G	PAD ASSEMBLY, tunnel top, gray . . . . . 89	1
2	6004566	HARDBOARD, tunnel top . . . . . 89	1
3	6005239G	CARPET, tunnel top, deluxe, gray . . . . . 83, 84, 90	1
3	6005239	CARPET, tunnel top, deluxe, tan . . . . . 83, 84, 90	1
3	6005240G	CARPET, tunnel top, deluxe w/aux seat, gray . . . . . 84	1
3	6005240	CARPET, tunnel top, deluxe w/aux seat, tan . . . . . 84	1
4	5939985G	PAD ASSEMBLY, tunnel top, RR, outer, gray . . . . . 83, 84, 90	2
4	5939985	PAD ASSEMBLY, tunnel top, RR, outer, tan . . . . . 83, 84, 90	2
5	6007184G	PAD ASSEMBLY, tunnel top, gray . . . . . 83, 90	1
5	6007184	PAD ASSEMBLY, tunnel top, tan . . . . . 83, 90	1
5	6007185G	PAD ASSEMBLY, tunnel top, gray . . . . . 84	1
5	6007185	PAD ASSEMBLY, tunnel top, tan . . . . . 84	1
6	6000870	HARDBOARD, tunnel top, RR, outer . . . . . 83, 84, 90	2
7	6005229	HARDBOARD, tunnel top . . . . . 83, 90	1
7	6005230	HARDBOARD, tunnel top . . . . . 84	1

# 2001 HUMMER PARTS CATALOG

## 10-116 BODY

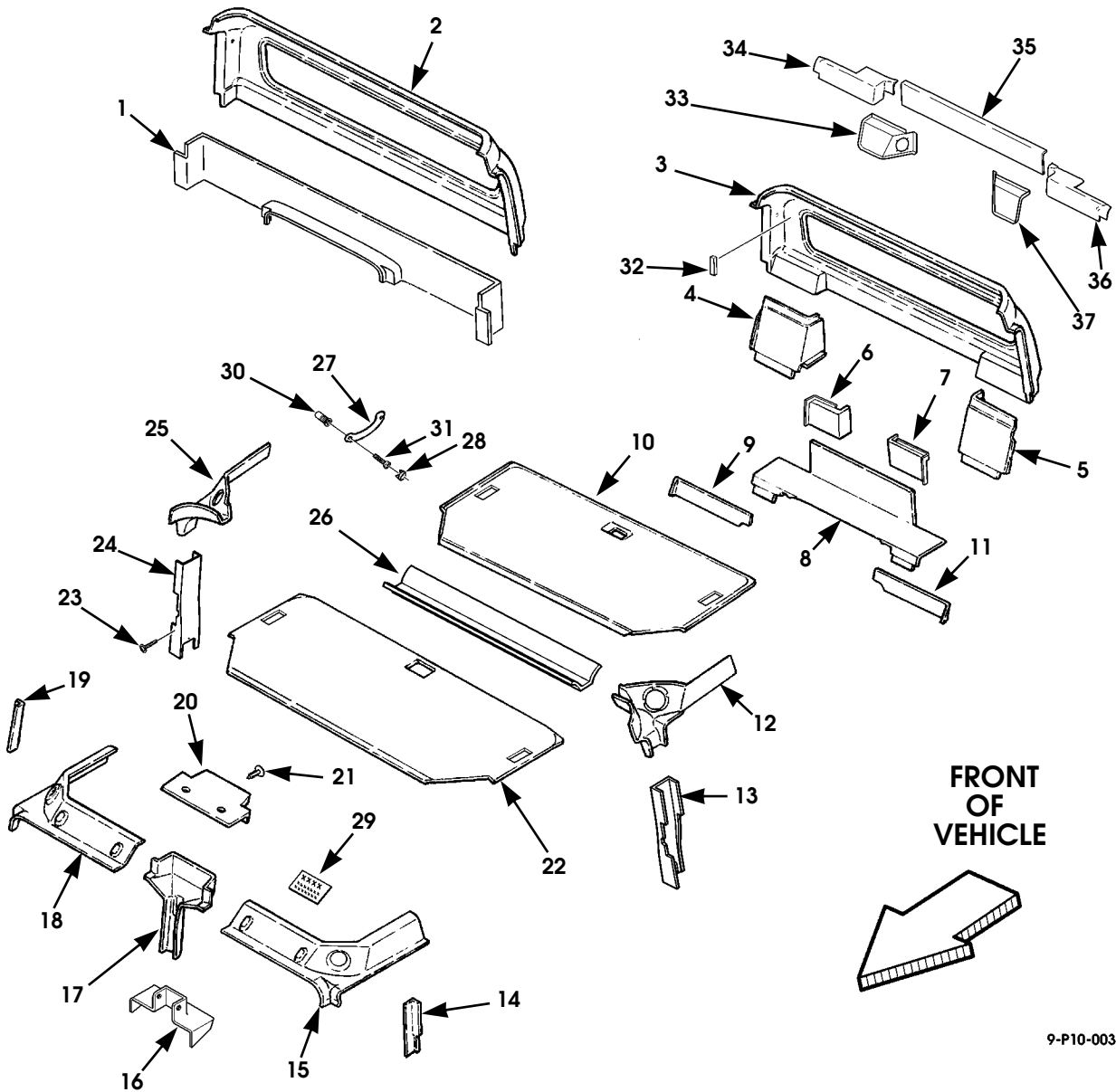

9-P10-003

Figure 10-44. Headliner, Roof Trim, Front and Rear Side Trim, Grab Handles, and Mounting Hardware (Delco Standard Stereo System).

# 2001 HUMMER PARTS CATALOG

**BODY 10-117**

ITEM	PART NUMBER	DESCRIPTION	QTY
		<b>Figure 10-44. Headliner, Roof Trim, Front and Rear Side Trim, Grab Handles, and Mounting Hardware (Delco Standard Stereo System).</b>	
1	6004545G	PANEL, rear, lower, gray . . . . .	1
		89	
2	6004546G	PANEL ASSEMBLY, rear, gray . . . . .	1
		89	
3	6003603G	PANEL ASSEMBLY TRIM, rear, gray . . . . .	1
		83	
3	6003603	PANEL ASSEMBLY TRIM, rear, tan . . . . .	1
		83	
4	6000184G	PANEL, wheelhouse, upper, R.H., gray . . . . .	1
		83	
4	6000184	PANEL, wheelhouse, upper, R.H., tan . . . . .	1
		83	
4	6002995G	PANEL, wheelhouse, upper, R.H., gray . . . . .	1
		84	
4	6002995	PANEL, wheelhouse, upper, R.H., tan . . . . .	1
		84	
5	6000183G	PANEL, wheelhouse, upper, L.H., gray . . . . .	1
		83	
5	6000183	PANEL, wheelhouse, upper, L.H., tan . . . . .	1
		83	
5	6002994G	PANEL, wheelhouse, upper, L.H., gray . . . . .	1
		84	
5	6002994	PANEL, wheelhouse, upper, L.H., tan . . . . .	1
		84	
6	6000186G	PANEL, amp cover, R.H., gray . . . . .	1
		83	
6	6000186	PANEL, amp cover, R.H., tan . . . . .	1
		83	
7	6000185G	PANEL, amp cover, L.H., gray . . . . .	1
		83	
7	6000185	PANEL, amp cover, L.H., tan . . . . .	1
		83	
8	6005125G	PANEL, rear lower, center, gray . . . . .	1
		83, 90	
8	6005125	PANEL, rear lower, center, tan . . . . .	1
		83, 90	
9	6000182G	PANEL, wheelhouse, lower, R.H., gray . . . . .	1
		83, 90	
9	6000182	PANEL, wheelhouse, lower, R.H., tan . . . . .	1
		83, 90	
9	6002993G	PANEL, wheelhouse, lower, R.H., gray . . . . .	1
		84	
9	6002993	PANEL, wheelhouse, lower, R.H., tan . . . . .	1
		84	

# 2001 HUMMER PARTS CATALOG

## 10-118 BODY

ITEM	PART NUMBER	DESCRIPTION	QTY
		<b>Figure 10-44. Headliner, Roof Trim, Front and Rear Side Trim, Grab Handles, and Mounting Hardware (Delco Standard Stereo System). (Cont'd)</b>	
10	6008643G	HEADLINER, rear, gray . . . . . 83	1
10	6008643	HEADLINER, rear, tan . . . . . 83	1
10	6008647G	HEADLINER, rear, gray . . . . . 84	1
10	6008647	HEADLINER, rear, tan . . . . . 84	1
11	6000181G	PANEL, wheelhouse, lower, L.H., gray . . . . . 83, 90	1
11	6000181	PANEL, wheelhouse, lower, L.H., tan. . . . . 83, 90	1
11	6002992G	PANEL, wheelhouse, lower, L.H., gray . . . . . 84	1
11	6002992	PANEL, wheelhouse, lower, L.H., tan . . . . . 84	1
12	6009125G	PANEL ASSEMBLY TRIM, L.H., B-pillar, upper, gray . . . . . 83, 84	1
12	6009125	PANEL ASSEMBLY TRIM, L.H., B-pillar, upper, tan. . . . . 83, 84	1
13	6005989G	PANEL ASSEMBLY TRIM, L.H., B-pillar, center, gray. . . . . 83, 84	1
13	6005989	PANEL ASSEMBLY TRIM, L.H., B-pillar, center, tan . . . . . 83, 84	1
14	5939313G	PANEL ASSEMBLY TRIM, L.H., A-pillar, gray . . . . . 83, 84, 89	1
14	5939313	PANEL ASSEMBLY TRIM, L.H., A-pillar, tan . . . . . 83, 84	1
15	6009123G	PANEL ASSEMBLY TRIM, L.H., front, upper, gray. . . . . 83, 84, 89	1
15	6009123	PANEL ASSEMBLY TRIM, L.H., front upper, tan . . . . . 83, 84	1
16	6010265G	PANEL, trim, lower, windshield divider bar, gray. . . . .	1
16	6010265	PANEL, trim, lower, windshield divider bar tan. . . . .	1
17	6010025G	PANEL ASSEMBLY TRIM, wiper motor, gray . . . . . 83, 84, 89	1
17	6010025	PANEL ASSEMBLY TRIM, wiper motor tan. . . . . 83, 84	1
17	6010159G	PANEL ASSEMBLY TRIM, wiper motor, gray . . . . . 90	1
17	6010159	PANEL ASSEMBLY TRIM, wiper motor, tan. . . . . 90	1

# 2001 HUMMER PARTS CATALOG

**BODY 10-119**

ITEM	PART NUMBER	DESCRIPTION	QTY
		<b>Figure 10-44. Headliner, Roof Trim, Front and Rear Side Trim, Grab Handles, and Mounting Hardware (Delco Standard Stereo System). (Cont'd)</b>	
18	6009124G	PANEL ASSEMBLY TRIM, R.H., front, upper, gray . . . . . 83, 84, 89	1
18	6009124	PANEL ASSEMBLY TRIM, R.H., front, upper, tan, . . . . . 83, 84	1
19	5939314G	PANEL ASSEMBLY TRIM, R.H., A-pillar, gray . . . . . 83, 84	1
19	5939314	PANEL ASSEMBLY TRIM, R.H., A-pillar, tan . . . . . 83, 84	1
20	6001025G	PANEL TRIM, upper wiper motor, gray . . . . . 90	1
20	6001025	PANEL TRIM, upper wiper motor, tan. . . . . 90	1
21	6001038G	BUTTON TRIM, gray . . . . . 90	4
21	6001038	BUTTON TRIM, tan . . . . . 90	4
22	6009326G	HEADLINER, front, gray . . . . . 89	1
22	6009133G	HEADLINER, front, gray . . . . . 83, 84	1
22	6009133	HEADLINER, front, tan . . . . . 83, 84	1
23	6000114G	TRIM SCREW, 3/4, gray . . . . . 83, 84	8
23	6000114	TRIM SCREW, 3/4, tan. . . . . 83, 84	8
24	6005990G	PANEL ASSEMBLY TRIM, R.H., B-pillar, center, gray . . . . . 83, 84	1
24	6005990	PANEL ASSEMBLY TRIM, R.H., B-pillar, center, tan . . . . . 83, 84	1
25	6009126G	PANEL ASSEMBLY TRIM, R.H., B-pillar, upper, gray . . . . . 83, 84	1
25	6009126	PANEL ASSEMBLY TRIM, R.H., B-pillar, upper, tan. . . . . 83, 84	1
26	6005150G	PANEL ASSEMBLY TRIM, B-bar cover, gray . . . . . 83, 84	1
26	6005150	PANEL ASSEMBLY TRIM, B-bar cover, tan . . . . . 83, 84	1



# 2001 HUMMER PARTS CATALOG

## 10-120 BODY

ITEM	PART NUMBER	DESCRIPTION	QTY
		<b>Figure 10-44. Headliner, Roof Trim, Front and Rear Side Trim, Grab Handles, and Mounting Hardware (Delco Standard Stereo System). (Cont'd)</b>	
27	5939469G	GRAB HANDLE, gray . . . . . 83, 84, 90	4
27	5939469G	GRAB HANDLE, gray . . . . . 89	2
27	5939469	GRAB HANDLE, tan . . . . . 83, 84, 90	4
28	6000027G	PLUG, grab handle, gray . . . . . 83, 84	8
28	6000027G	PLUG, grab handle, gray . . . . . 89	4
28	6000027	PLUG, grab handle, tan . . . . . 83, 84	8
29	6008183	DECAL, handling warning . . . . .	1
30	N/S	NUT INSERT, 14 - 20 . . . . . 83, 84, 90	8
30	N/S	NUT INSERT, 1/4 - 20 . . . . . 89	4
31	N/S	BOLT, phcr, 1/4 - 20 x 3/4 . . . . . 83, 84, 90	8
31	N/S	BOLT, phcr, 1/4 - 20 x 3/4 . . . . . 89	4
32	6001007	SPACER, foam rubber, cab rear panel trim . . . . . 83, 89	12
33	6009128G	PANEL, speaker, R.H., gray . . . . . 90	1
33	6009128	PANEL, speaker, R.H., tan . . . . . 90	1
34	6009766G	PANEL, wheelhouse, upper, R.H., gray . . . . . 90	1
34	6009766	PANEL, wheelhouse, upper, R.H., tan . . . . . 90	1
35	6001032G	PANEL ASSEMBLY, rear, gray . . . . . 90	1
35	6001032	PANEL ASSEMBLY, rear, tan . . . . . 90	1
36	6009765G	PANEL, wheelhouse, upper, L.H., gray . . . . . 90	1
36	6009765	PANEL, wheelhouse, upper, L.H., tan . . . . . 90	1
37	6009127G	PANEL, speaker, L.H., gray . . . . . 90	1
37	6009127	PANEL, speaker, L.H., tan . . . . . 90	1

# 2001 HUMMER PARTS CATALOG

BODY 10-121

# 2001 HUMMER PARTS CATALOG

## 10-122 BODY

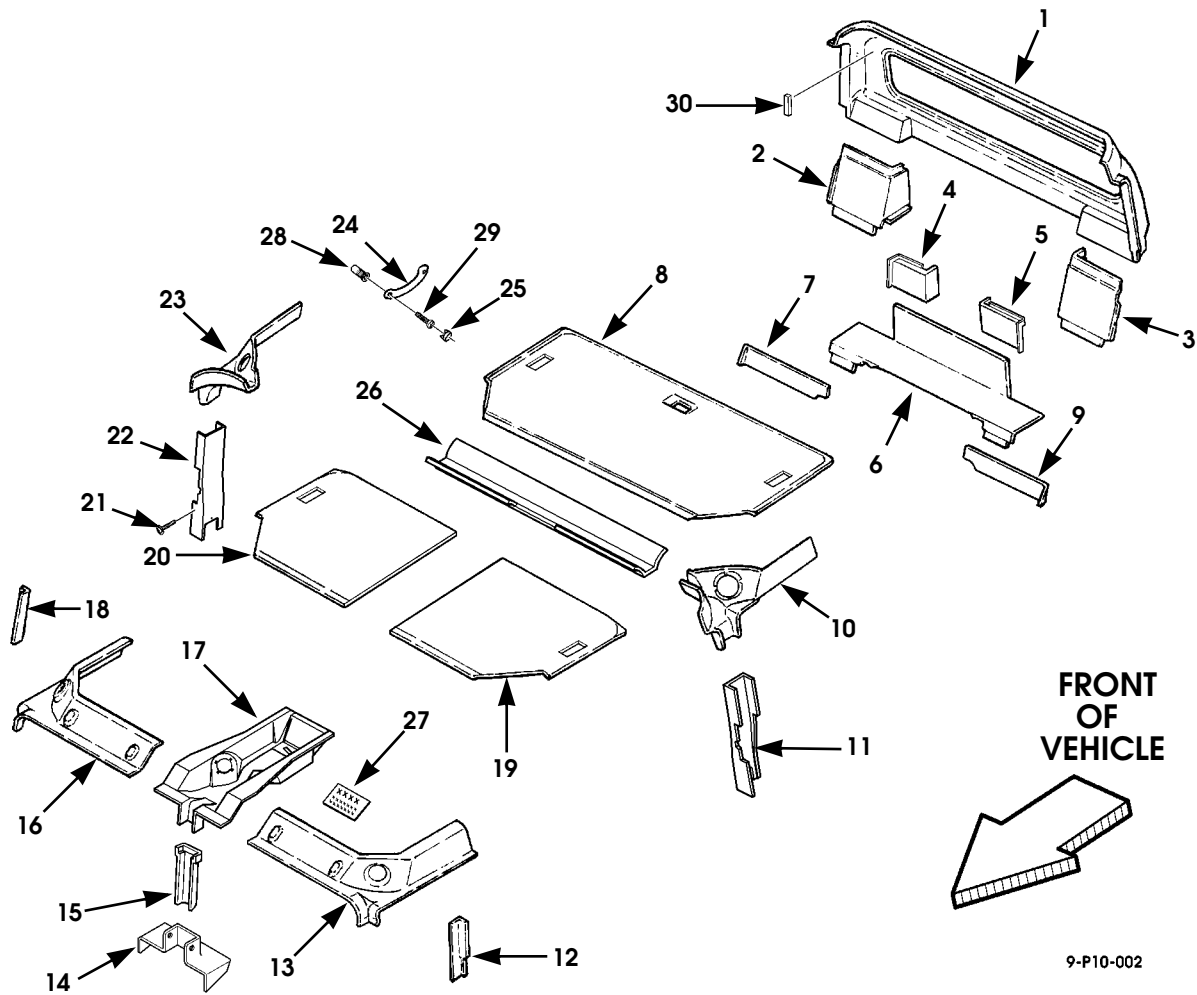

9-P10-002

Figure 10-45. Headliner, Roof Trim, Front and Rear Side Trim, Grab Handles, and Mounting Hardware (Delco Monsoon Stereo System)

# 2001 HUMMER PARTS CATALOG

**BODY 10-123**

ITEM	PART NUMBER	DESCRIPTION	QTY
		<b>Figure 10-45. Headliner, Roof Trim, Front and Rear Side Trim, Grab Handles, and Mounting Hardware (Delco Monsoon Stereo System)</b>	
1	6003603G	PANEL ASSEMBLY TRIM, rear, gray . . . . . 83	1
1	6003603	PANEL ASSEMBLY TRIM, rear, tan . . . . . 83	1
2	6000184G	PANEL, wheelhouse, upper, R.H., gray . . . . . 83	1
2	6000184	PANEL, wheelhouse, upper, R.H., tan . . . . . 83	1
2	6002995G	PANEL, wheelhouse, upper, R.H., gray . . . . . 84	1
2	6002995	PANEL, wheelhouse, upper, R.H., tan . . . . . 84	1
3	6000183G	PANEL, wheelhouse, upper, L.H., gray . . . . . 83	1
3	6000183	PANEL, wheelhouse, upper, L.H., tan . . . . . 83	1
3	6002994G	PANEL, wheelhouse, upper, L.H., gray . . . . . 84	1
3	6002994	PANEL, wheelhouse, upper, L.H., tan . . . . . 84	1
4	6000186G	PANEL, amp cover, R.H., gray . . . . . 83	1
4	6000186	PANEL, amp cover, R.H., tan . . . . . 83	1
5	6000185G	PANEL, amp cover, L.H., gray . . . . . 83	1
5	6000185	PANEL, amp cover, L.H., tan . . . . . 83	1
6	6005125G	PANEL, rear lower, center, gray . . . . . 83	1
6	6005125	PANEL, rear lower, center, tan . . . . . 83	1
7	6000182G	PANEL, wheelhouse, lower, R.H., gray . . . . . 83	1
7	6000182	PANEL, wheelhouse, lower, R.H., tan . . . . . 83	1

# 2001 HUMMER PARTS CATALOG

## 10-124 BODY

ITEM	PART NUMBER	DESCRIPTION	QTY
		<b>Figure 10-45. Headliner, Roof Trim, Front and Rear Side Trim, Grab Handles, and Mounting Hardware (Delco Monsoon Stereo System) (Cont'd)</b>	
7	6002993G	PANEL, wheelhouse, lower, R.H., gray . . . . . 84	1
7	6002993	PANEL, wheelhouse, lower, R.H., tan . . . . . 84	1
8	6008643G	HEADLINER, rear, gray . . . . . 83	1
8	6008643	HEADLINER, rear, tan . . . . . 83	1
8	6008647G	HEADLINER, rear, gray . . . . . 84	1
8	6008647	HEADLINER, rear, tan . . . . . 84	1
9	6000181G	PANEL, wheelhouse, lower, L.H., gray . . . . . 83	1
9	6000181	PANEL, wheelhouse, lower, L.H., tan . . . . . 83	1
9	6002992G	PANEL, wheelhouse, lower, L.H., gray . . . . . 84	1
9	6002992	PANEL, wheelhouse, lower, L.H., tan . . . . . 84	1
10	6009125G	PANEL ASSEMBLY TRIM, L.H., B-pillar, upper, gray . . . . . 83, 84	1
10	6009125	PANEL ASSEMBLY TRIM, L.H., B-pillar, upper, tan . . . . . 83, 84	1
11	6005989G	PANEL ASSEMBLY TRIM, L.H., B-pillar, center, gray . . . . . 83, 84	1
11	6005989	PANEL ASSEMBLY TRIM, L.H., B-pillar, center, tan . . . . . 83, 84	1
12	5939313G	PANEL ASSEMBLY TRIM, L.H., A-pillar, gray . . . . . 83, 84	1
12	5939313	PANEL ASSEMBLY TRIM, L.H., A-pillar, tan . . . . . 83, 84	1
13	6009123G	PANEL ASSEMBLY TRIM, L.H., front, upper, gray . . . . . 83, 84	1
13	6009123	PANEL ASSEMBLY TRIM, L.H., front, upper, tan . . . . . 83, 84	1

# 2001 HUMMER PARTS CATALOG

**BODY 10-125**

ITEM	PART NUMBER	DESCRIPTION	QTY
		<b>Figure 10-45. Headliner, Roof Trim, Front and Rear Side Trim, Grab Handles, and Mounting Hardware (Delco Monsoon Stereo System) (Cont'd)</b>	
14	6010941G	PANEL, trim, gray, w/o heated w/s. . . . .	1
14	6010941	PANEL, trim, tan, w/o heated w/s. . . . .	1
14	6010265G	PANEL, trim, lower, windshield divider bar w/ heated w/s . . . . .	1
14	6010265	PANEL, trim, lower, windshield divider bar w/ heated w/s. . . . .	1
15	6010162G	COVER, windshield divider bar, gray . . . . .	1
15	6010162	COVER, windshield divider bar, tan . . . . .	1
16	6009124G	PANEL ASSEMBLY TRIM, R.H., front, upper, gray . . . . .	1
16	6009124	PANEL ASSEMBLY TRIM, R.H., front, upper, tan. . . . .	1
17	6010161G	OVERHEAD CONSOLE, gray . . . . .	1
17	6010161	OVERHEAD CONSOLE, tan . . . . .	1
18	5939314G	PANEL ASSEMBLY TRIM, R.H., A-pillar, gray . . . . .	1
18	5939314	PANEL ASSEMBLY TRIM, R.H., A-pillar, tan. . . . .	1
19	6009131G	HEADLINER, front, left, gray . . . . .	1
19	6009131	HEADLINER, front, left, tan . . . . .	1
20	6009132G	HEADLINER, front, right, gray . . . . .	1
20	6009132	HEADLINER, front, right, tan . . . . .	1
21	6000114G	TRIM SCREW, 3/4, gray . . . . .	8
21	6000114	TRIM SCREW, 3/4, tan. . . . .	8
22	6005990G	PANEL ASSEMBLY TRIM, R.H., B-pillar, center, gray . . . . .	1
22	6005990	PANEL ASSEMBLY TRIM, R.H., B-pillar, center, tan . . . . .	1

# 2001 HUMMER PARTS CATALOG

## 10-126 BODY

ITEM	PART NUMBER	DESCRIPTION	QTY
		<b>Figure 10-45. Headliner, Roof Trim, Front and Rear Side Trim, Grab Handles, and Mounting Hardware (Delco Monsoon Stereo System) (Cont'd)</b>	
23	6009126G	PANEL ASSEMBLY TRIM, R.H., B-pillar, upper, gray . . . . . 83, 84	1
23	6009126	PANEL ASSEMBLY TRIM, R.H., B-pillar, upper, tan . . . . . 83, 84	1
24	5939469G	GRAB HANDLE, gray . . . . . 83, 84, 89, 90	4
24	5939469	GRAB HANDLE, tan . . . . . 83, 84, 90	4
25	6000027G	PLUG, grab handle, gray . . . . . 83, 84	8
25	6000027	PLUG, grab handle, tan . . . . . 83, 84	8
26	6008881G	COVER, B-bar, gray . . . . . 83, 84	1
26	6008881	COVER, B-bar, tan . . . . . 83, 84	1
27	6008183	DECAL, handling warning . . . . .	1
28	N/S	NUT INSERT, 1/4 - 20 . . . . .	8
29	N/S	BOLT, phcr, 1/4 - 20 x 3/4 . . . . .	8
30	6001007	SPACER, foam rubber, rear window trim . . . . . 83, 89	12





# 2001 HUMMER PARTS CATALOG

## 10-128 BODY

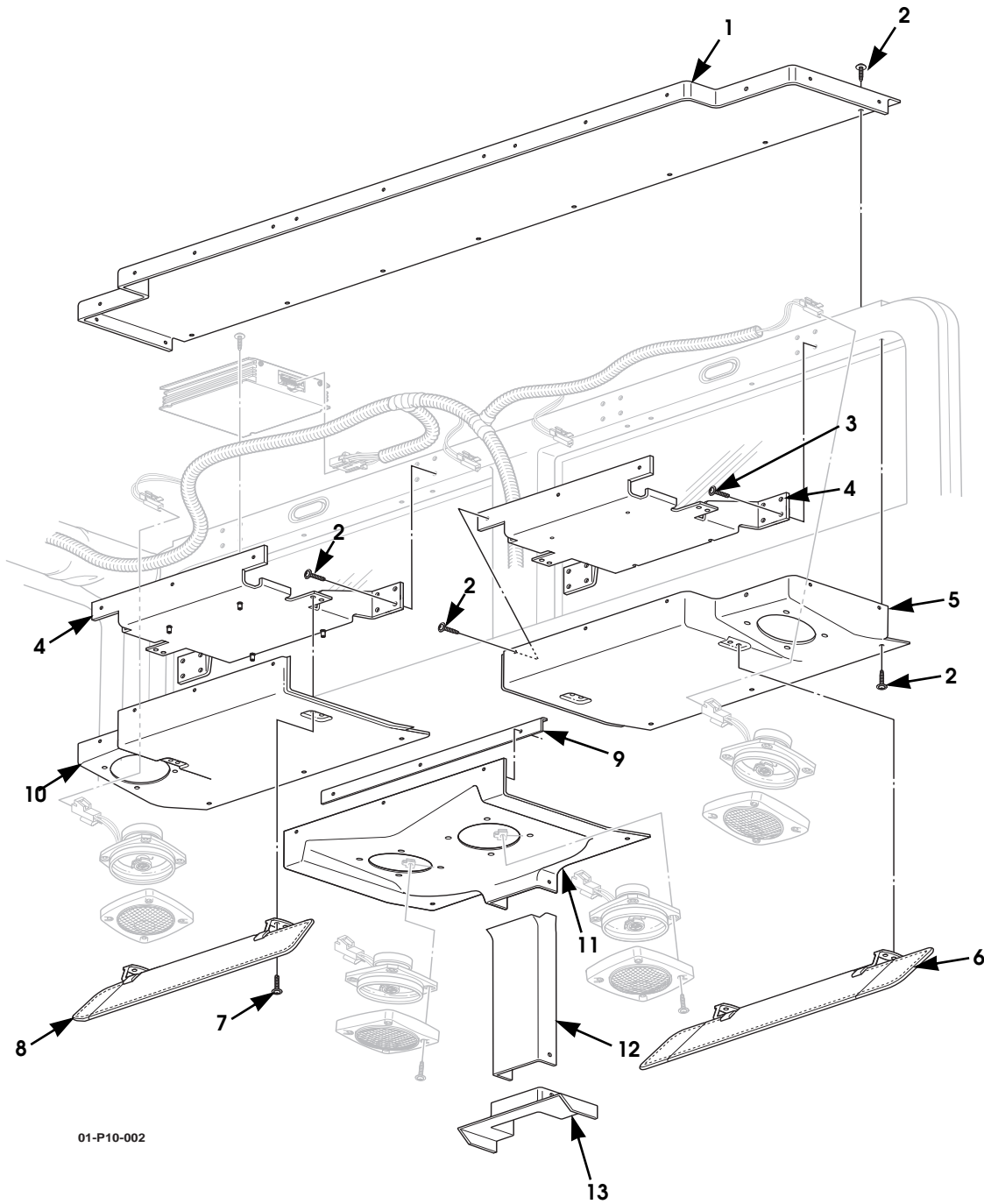

Figure 10-46. Monsoon Trim Pieces, Model 90.

# 2001 HUMMER PARTS CATALOG

**BODY 10-129**

ITEM	PART NUMBER	DESCRIPTION	QTY
		<b>Figure 10-46. Monsoon Trim Pieces, Model 90.</b>	
1	6011525	TOP COVER, overhead console . . . . .	1
2	6000243	TRIM SCREW . . . . .	30
3	MS35206-265	SCREW, phcr. . . . .	16
4	6011524	MOUNTING BRACKET, overhead console . . . . .	2
5	6011528	TRIM PANEL, overhead, lower R.H. . . . .	1
6	6011865	VISOR, deluxe, R.H., black. . . . .	1
7	MS35206-266	SCREW, phcr. . . . .	8
8	6011864	VISOR, deluxe, L.H., black . . . . .	1
9	6011919	REINFORCEMENT, center trim panel . . . . .	1
10	6011527	TRIM PANEL, overhead, lower, L.H. . . . .	1
11	6011531	TRIM PANEL, center windshield. . . . .	1
12	6011867	TRIM PANEL, windshield . . . . .	1
13	6011866	PANEL, divider bar trim . . . . .	1

# 2001 HUMMER PARTS CATALOG

## 10-130 BODY

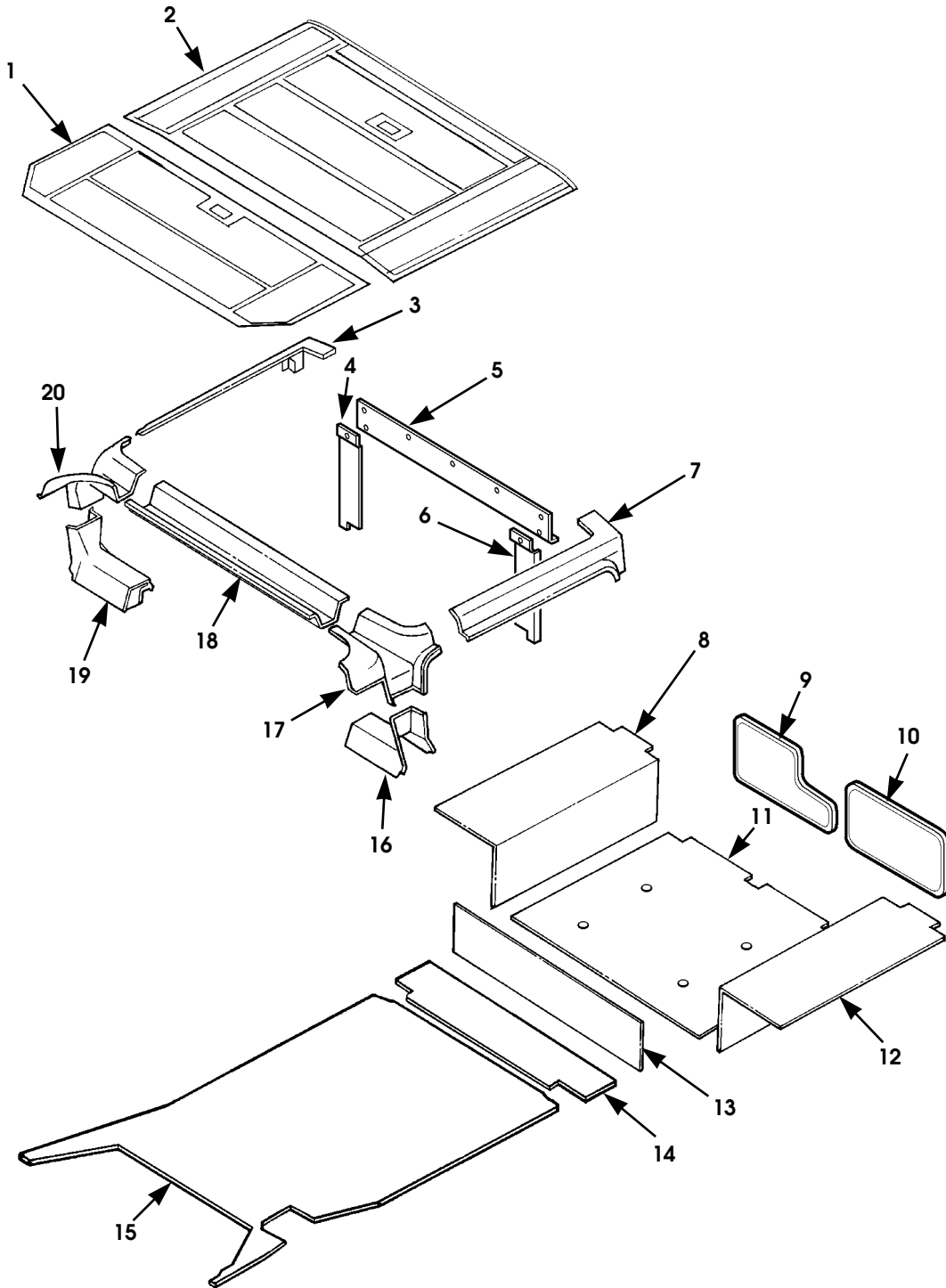

P10-044.3

Figure 10-47. Headliner, Rear Trim, and Carpet, Station Wagon, Model 84.

# 2001 HUMMER PARTS CATALOG

**BODY 10-131**

ITEM	PART NUMBER	DESCRIPTION	QTY
		<b>Figure 10-47. Headliner, Rear Trim, and Carpet, Station Wagon, Model 84.</b>	
1	6008647G	HEADLINER, center, gray . . . . .	1
1	6008647	HEADLINER, center, tan . . . . .	1
2	6008645G	HEADLINER, rear, gray . . . . .	1
2	6008645	HEADLINER, rear, tan . . . . .	1
3	6008835G	PANEL, upper rear, R.H., gray . . . . .	1
3	6008835	PANEL, upper rear, R.H., tan . . . . .	1
4	6008578	PANEL, black trim, cargo door, R.H. . . . .	1
5	6008579	PANEL, black trim, cargo door, upper . . . . .	1
6	6008577	PANEL, black trim, cargo door, L.H. . . . .	1
7	6008834G	PANEL, upper rear, L.H., gray . . . . .	1
7	6008834	PANEL, upper rear, L.H., tan . . . . .	1
8	6001109G	CARPET, wheelhouse, R.H., gray . . . . .	1
8	6001109	CARPET, wheelhouse, R.H., tan . . . . .	1
9	6006152G	CARPET, cargo door, R.H., gray . . . . .	1
9	6006152	CARPET, cargo door, R.H., tan . . . . .	1
10	6006151G	CARPET, cargo door, L.H., gray . . . . .	1
10	6006151	CARPET, cargo door, L.H., tan . . . . .	1
11	6006130G	CARPET, cargo floor, gray . . . . .	1
11	6006130	CARPET, cargo floor, tan . . . . .	1
12	6001108G	CARPET, wheelhouse, L.H., gray . . . . .	1
12	6001108	CARPET, wheelhouse, L.H., tan . . . . .	1
13	6002998G	CARPET, bulkhead, gray . . . . .	1
13	6002998	CARPET, bulkhead, tan . . . . .	1
14	6002988G	CARPET ASSY, tunnel, center, gray . . . . .	1
14	6002988	CARPET ASSY, tunnel, center, tan . . . . .	1
15	6007185G	PAD ASSY, tunnel, center, gray . . . . .	1
15	6007185	PAD ASSY, tunnel, center, tan . . . . .	1
16	6002981G	PANEL, C-pillar, lower, L.H., gray . . . . .	1
16	6002981	PANEL, C-pillar, lower, L.H., tan . . . . .	1
17	6001068G	PANEL, C-pillar, upper, L.H., gray . . . . .	1
17	6001068	PANEL, C-pillar, upper, L.H., tan . . . . .	1
18	6001078G	PANEL, C-pillar, center, gray . . . . .	1
18	6001078	PANEL, C-pillar, center, tan . . . . .	1
19	6002982G	PANEL, C-pillar, lower, R.H., gray . . . . .	1
19	6002982	PANEL, C-pillar, lower, R.H., tan . . . . .	1
20	6001069G	PANEL, C-pillar, upper, R.H., gray . . . . .	1
20	6001069	PANEL, C-pillar, upper, R.H., tan . . . . .	1

# 2001 HUMMER PARTS CATALOG

## 10-132 BODY

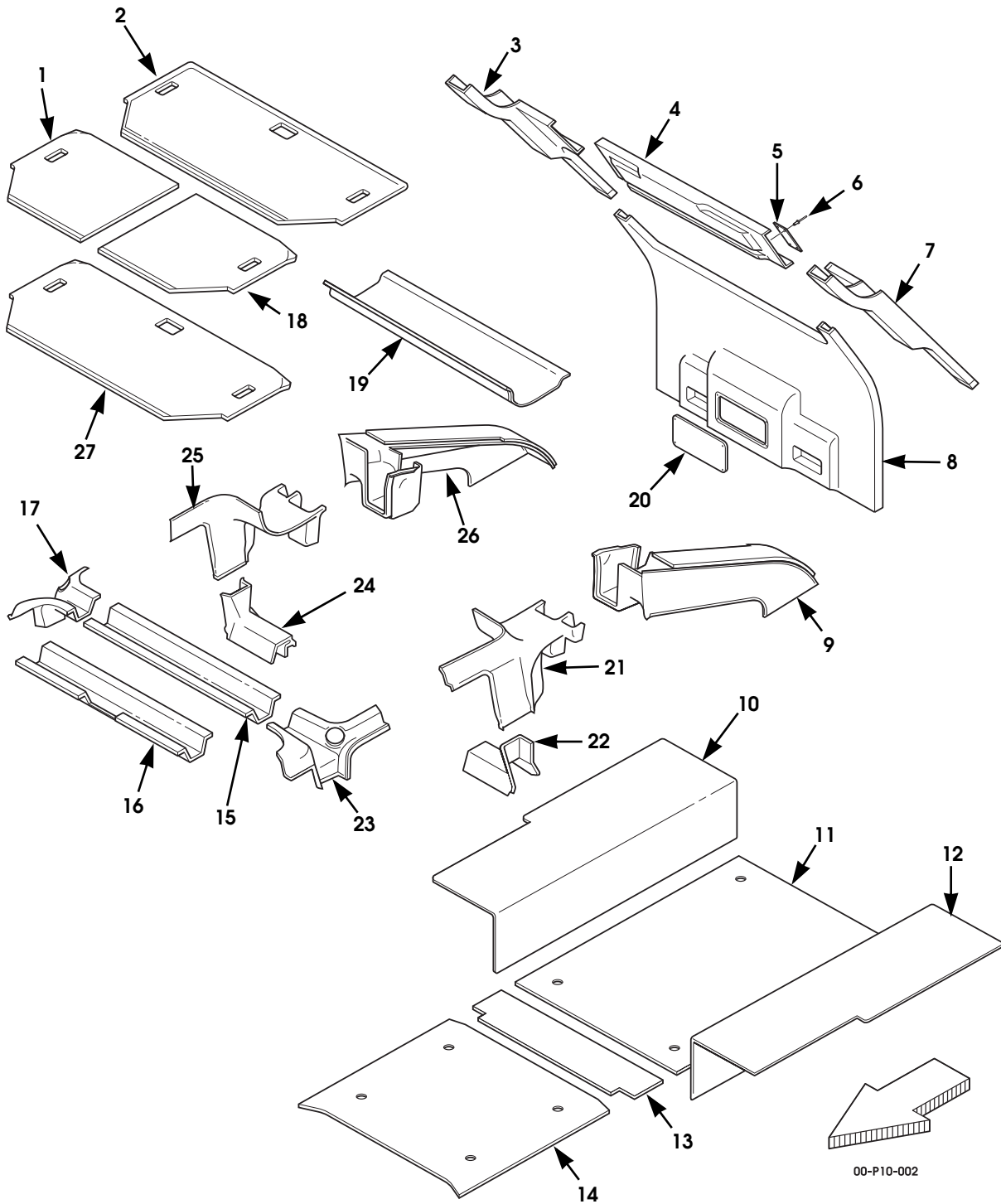

Figure 10-48. Headliner, Rear Trim and Carpet, Slant-Back, Model 91.

# 2001 HUMMER PARTS CATALOG

**BODY 10-133**

ITEM	PART NUMBER	DESCRIPTION	QTY
		<b>Figure 10-48.</b> <b>Headliner, Rear Trim and Carpet, Slant-Back, Model 91.</b>	
1	6009132G	HEADLINER, front, right, gray . . . . .	1
1	6009132	HEADLINER, front, right, tan . . . . .	1
2	6010691G	TRIM PANEL, rear headliner, gray . . . . .	1
2	6010691	TRIM PANEL, rear headliner, tan . . . . .	1
3	6010995G	TRIM PANEL, upper R.H., gray . . . . .	1
3	6010995	TRIM PANEL, upper R.H., tan . . . . .	1
4	6011032G	TRIM PANEL ASSEMBLY DOOR, upper center, gray . . . . .	1
4	6011032	TRIM PANEL ASSEMBLY DOOR, upper center, tan . . . . .	1
5	N/S	•BACKING PLATES . . . . .	2
6	N/S	•RIVET, 1/8, blind . . . . .	4
7	6010994G	TRIM PANEL, upper L.H., gray . . . . .	1
7	6010994	TRIM PANEL, upper L.H., tan . . . . .	1
8	6010993G	TRIM PANEL, lower, gray . . . . .	1
8	6010993	TRIM PANEL, lower, tan . . . . .	1
9	6010982G	TRIM PANEL, slant-back upper, L.H., gray . . . . .	1
9	6010982	TRIM PANEL, slant-back upper, L.H., tan . . . . .	1
10	6011824G	CARPET ASSEMBLY, slant-back wheelhouse, R.H., gray . . . . .	1
10	6011824	CARPET ASSEMBLY, slant-back wheelhouse, R.H., tan . . . . .	1
11	6011002G	CARPET ASSEMBLY, slant-back cargo floor, gray . . . . .	1
11	6011002	CARPET ASSEMBLY, slant-back cargo floor, tan . . . . .	1
12	6011823G	CARPET ASSEMBLY, slant-back wheelhouse, L.H., gray . . . . .	1
12	6011823	CARPET ASSEMBLY, slant-back wheelhouse, L.H., tan . . . . .	1
13	6002988G	CARPET ASSEMBLY, slant-back, tunnel, center, gray . . . . .	1
13	6002988	CARPET ASSEMBLY, slant-back, tunnel, center, tan . . . . .	1
14	6005240G	PAD ASSEMBLY, slant-back, tunnel, center, gray . . . . .	1
14	6005240	PAD ASSEMBLY, slant-back, tunnel, center, tan . . . . .	1
15	6005150G	COVER, B-bar, slant-back, standard, gray . . . . .	1
15	6005150	COVER, B-bar, slant-back, standard, tan . . . . .	1
16	6008881G	COVER, B-bar, slant-back, Monsoon, gray . . . . .	1
16	6008881	COVER, B-bar, slant-back, Monsoon, tan . . . . .	1
17	6009126G	PANEL ASSEMBLY, trim, B-pillar upper, R.H., gray . . . . .	1
17	6009126	PANEL ASSEMBLY, trim, B-pillar upper, R.H., tan . . . . .	1
18	6009131G	HEADLINER, front, left, gray . . . . .	1
18	6009131	HEADLINER, front, left, tan . . . . .	1
19	6010992G	TRIM PANEL, C-pillar center, gray . . . . .	1
19	6010992	TRIM PANEL, C-pillar center, tan . . . . .	1
20	6011016G	TRIM PANEL, slant-back door, closeout, gray . . . . .	1
20	6011016	TRIM PANEL, slant-back door, closeout, tan . . . . .	1
21	6010986G	TRIM PANEL, slant-back, C-pillar upper, L.H., gray . . . . .	1
21	6010986	TRIM PANEL, slant-back, C-pillar upper, L.H., tan . . . . .	1

# 2001 HUMMER PARTS CATALOG

## 10-134 BODY

ITEM	PART NUMBER	DESCRIPTION	QTY
		<b>Figure 10-48.</b> <b>Headliner, Rear Trim and Carpet, Slant-Back, Model 91.</b> <b>(Cont'd.)</b>	
22	6010990G	PANEL ASSEMBLY, trim, C-pillar, lower L.H., gray . . . . .	1
22	6010990	PANEL ASSEMBLY, trim, C-pillar, lower L.H., tan . . . . .	1
23	6009125G	PANEL ASSEMBLY, trim, B-pillar upper, L.H., gray . . . . .	1
23	6009125	PANEL ASSEMBLY, trim, B-pillar upper, L.H., tan . . . . .	1
24	6010991G	PANEL ASSEMBLY, trim, C-pillar, lower R.H., gray . . . . .	1
24	6010991	PANEL ASSEMBLY, trim, C-pillar, lower R.H., tan . . . . .	1
25	6010987G	TRIM PANEL, slant-back C-pillar, upper R.H., gray . . . . .	1
25	6010987	TRIM PANEL, slant-back C-pillar, upper R.H., tan . . . . .	1
26	6010983G	TRIM PANEL, slant-back, upper R.H., gray . . . . .	1
26	6010983	TRIM PANEL, slant-back, upper R.H., tan . . . . .	1
27	6009133G	TRIM PANEL, front, headliner, for standard radio, gray.	1
27	6009133	TRIM PANEL, front, headliner, for standard radio, tan.	1
	6011822	TRIM PANEL ASSEMBLY, cargo window, L.H. (not illustrated) . . . . .	1
	6011833	TRIM PANEL ASSEMBLY, cargo window, R.H. (not illustrated) . . . . .	1

# 2001 HUMMER PARTS CATALOG

BODY 10-135



# 2001 HUMMER PARTS CATALOG

## 10-136 BODY

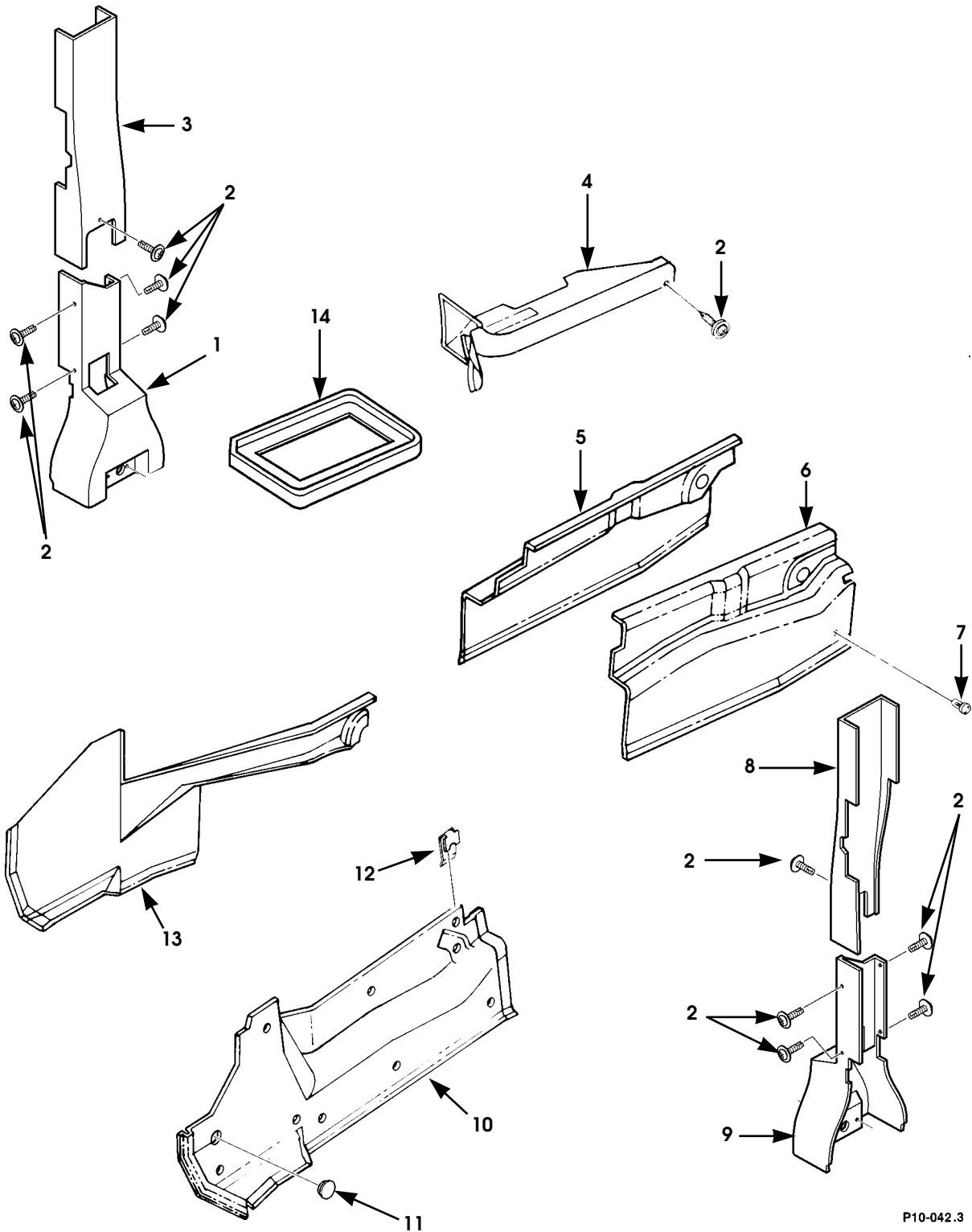

P10-042.3

Figure 10-49. Inner Kick Panels and Miscellaneous Trim Panels.

# 2001 HUMMER PARTS CATALOG

**BODY 10-137**

ITEM	PART NUMBER	DESCRIPTION	QTY
		<b>Figure 10-49. Inner Kick Panels and Miscellaneous Trim Panels.</b>	
1	6005190G	PANEL, B-pillar, lower, R.H., gray . . . . .	1
		89	
1	6004869G	PANEL, B pillar, lower, R.H. gray . . . . .	1
		83, 84, 90	
1	6004869	PANEL, B pillar, lower, R.H. tan . . . . .	1
		83, 84, 90	
2	6002686G	SCREW AND WASHER ASSEMBLY, #8 - 18 x 1, gray . . . .	v
		SEE NOTE 1	
2	6002686	SCREW AND WASHER ASSEMBLY, #8 - 18 x 1, tan . . . .	v
		SEE NOTE 1	
3	6009784G	PANEL, B-pillar, center trim, R.H., gray. . . . .	1
		90	
3	6009784	PANEL, B-pillar, center trim, R.H., tan. . . . .	1
		90	
4	6007187G	PANEL, shift and parking brake, gray . . . . .	1
		83, 84, 89, 90	
4	6007187	PANEL, shift and parking brake, tan. . . . .	1
		83, 84, 90	
5	6005538G	PANEL, kick, inner rear, R.H., gray . . . . .	1
		89	
5	6005539G	PANEL, kick, inner rear, R.H., gray . . . . .	1
		83, 84, 90	
5	6005539	PANEL, kick, inner rear, R.H., tan . . . . .	1
		83, 84, 90	
6	6004544G	PANEL, kick, inner rear, L.H., gray . . . . .	1
		89	
6	6003434G	PANEL, kick, inner rear, L.H., gray . . . . .	1
		83, 84, 90	
6	6003434	PANEL, kick, inner rear, L.H., tan . . . . .	1
		83, 84, 90	
7	6000475G	CLIP, trim, gray . . . . .	42
7	6000475	CLIP, trim, tan . . . . .	42

# 2001 HUMMER PARTS CATALOG

## 10-138 BODY

ITEM	PART NUMBER	DESCRIPTION	QTY
		<b>Figure 10-49. Inner Kick Panels and Miscellaneous Trim Panels. (Cont'd)</b>	
8	6009783G	PANEL, B-pillar, center trim, L.H., gray . . . . .	1
		90	
8	6009783	PANEL, B-pillar, center trim, L.H., tan . . . . .	1
		90	
9	6004868G	PANEL, B pillar, lower, L.H. gray . . . . .	1
		83, 84, 90	
9	6004868	PANEL, B pillar, lower, L.H. tan . . . . .	1
		83, 84, 90	
9	6005189G	PANEL, B-pillar, lower L.H. gray . . . . .	1
		89	
10	6005542G	PANEL, kick, inner front, L.H. gray . . . . .	1
		89	
10	6010337G	PANEL, kick, inner front, L.H. gray . . . . .	1
		83, 84, 90	
10	6010337	PANEL, kick, inner front, L.H. tan . . . . .	1
		83, 84, 90	
11	6007190	PLUG, kick panel . . . . .	1
12	6000391	SPEEDNUT . . . . .	56
13	6009383G	PANEL, inner front, R.H., gray . . . . .	1
		83, 84, 90	
13	6009383	PANEL, inner front, R.H., tan . . . . .	1
		83, 84, 90	
14	6007186	BEZEL, shifter . . . . .	1
		 NOTE 1: NUMBER OF SCREW AND WASHER ASSEMBLIES NEEDED PER PANEL: 4 NEEDED FOR EACH ITEM 1 PANEL 1 NEEDED FOR EACH ITEM 3 PANEL 56 NEEDED FOR EACH ITEM 4 PANEL 1 NEEDED FOR EACH ITEM 8 PANEL 4 NEEDED FOR EACH ITEM 9 PANEL	

# 2001 HUMMER PARTS CATALOG

## HEATING/VENTILATION/AIR CONDITIONING 11-1

### Section 11

## HEATING/VENTILATION/AIR CONDITIONING

TITLE	PAGE NUMBER
A/C Compressor and Mounting Hardware . . . . .	11-4
A/C-Heat Vacuum and Temperature Door Motors . . . . .	11-12
Auxiliary A/C-Heat Hoses . . . . .	11-30
Auxiliary A/C-Heat . . . . .	11-26
Auxiliary HVAC Unit . . . . .	11-28
Climate Control Panel . . . . .	11-2
Closeout Panel, Driver's . . . . .	11-20
Closeout Panel, Passenger's . . . . .	11-22
Condenser, Receiver/Dryer, and A/C Hoses . . . . .	11-6
Main A/C-Heat Case Halves and Blower Motor . . . . .	11-14
Main A/C-Heat Evaporator and Heater Core Assemblies . . . . .	11-16
Main A/C-Heat Unit . . . . .	11-10
Plenum and Related Parts . . . . .	11-18
Rear Center Console . . . . .	11-32
Water Control Valve and Heater Hoses . . . . .	11-8
Wiring Harnesses, A/C-Heat . . . . .	11-24

# 2001 HUMMER PARTS CATALOG

## 11-2 HEATING/VENTILATION/AIR CONDITIONING

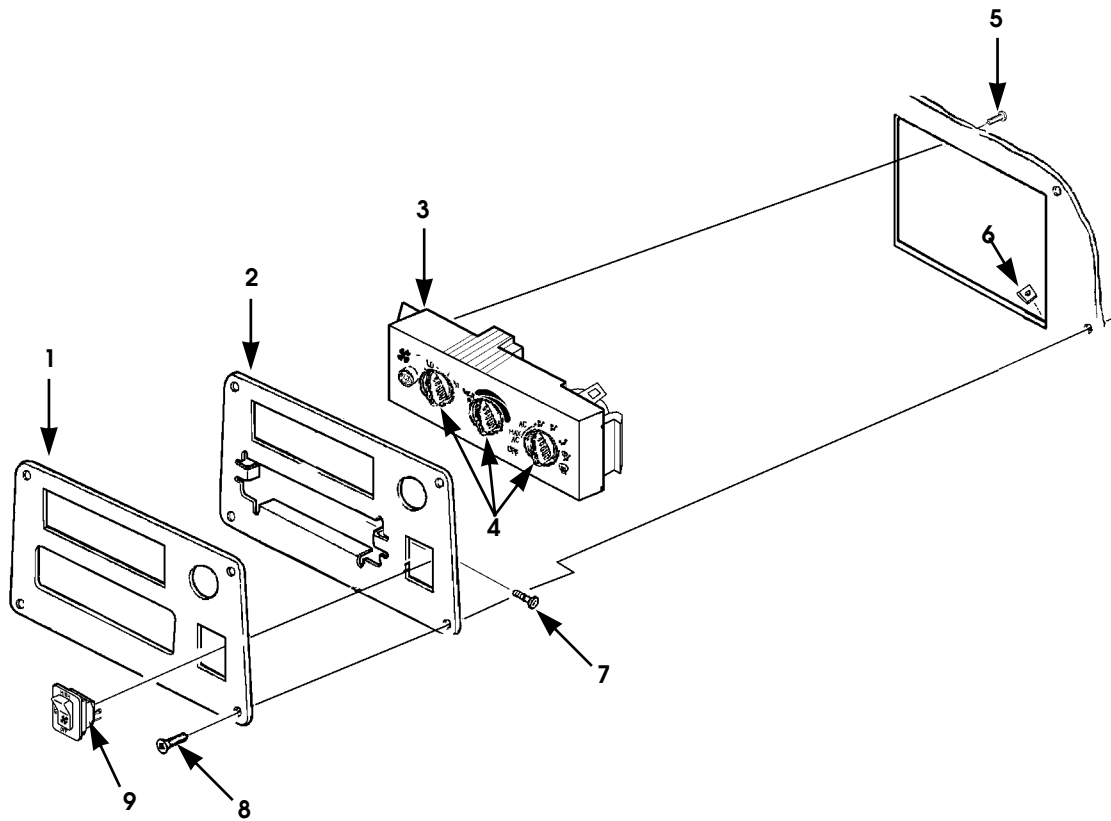

P11-029.5

Figure 11-1. Climate Control Panel.

# 2001 HUMMER PARTS CATALOG

## HEATING/VENTILATION/AIR CONDITIONING 11-3

ITEM	PART NUMBER	DESCRIPTION	QTY
		<b>Figure 11-1. Climate Control Panel.</b>	
1	6007462	BEZEL, HVAC controller, w/o radio . . . . .	1
1	6009463	BEZEL, HVAC controller, w/radio . . . . .	1
2	6009106B9	RETAINER ASSEMBLY, radio/HVAC . . . . .	1
3	6011452	PANEL, control, (heat only) w/o rear defogger . . . . .	1
3	6011453	PANEL, control, (heat only) w/rear defogger . . . . .	1
3	6011451	PANEL, control, HVAC w/o rear window defogger . . . . .	1
3	6011450	PANEL, control, HVAC w/rear window defogger . . . . .	1
4	5744922	•KNOB, control panel . . . . .	3
5	N/S	SCREW, tapping, phcr, #8 - 32 x 5/8 . . . . .	1
6	12341352	SPEEDNUT, climate control panel. . . . .	4
7	N/S	SCREW, trim, tapping, #8 x 1/2" . . . . .	1
8	5939651P2	SCREW . . . . .	4
9	5743502	SWITCH, two-speed rocker, aux. heat - A/C . . . . .	1

# 2001 HUMMER PARTS CATALOG

## 11-4 HEATING/VENTILATION/AIR CONDITIONING

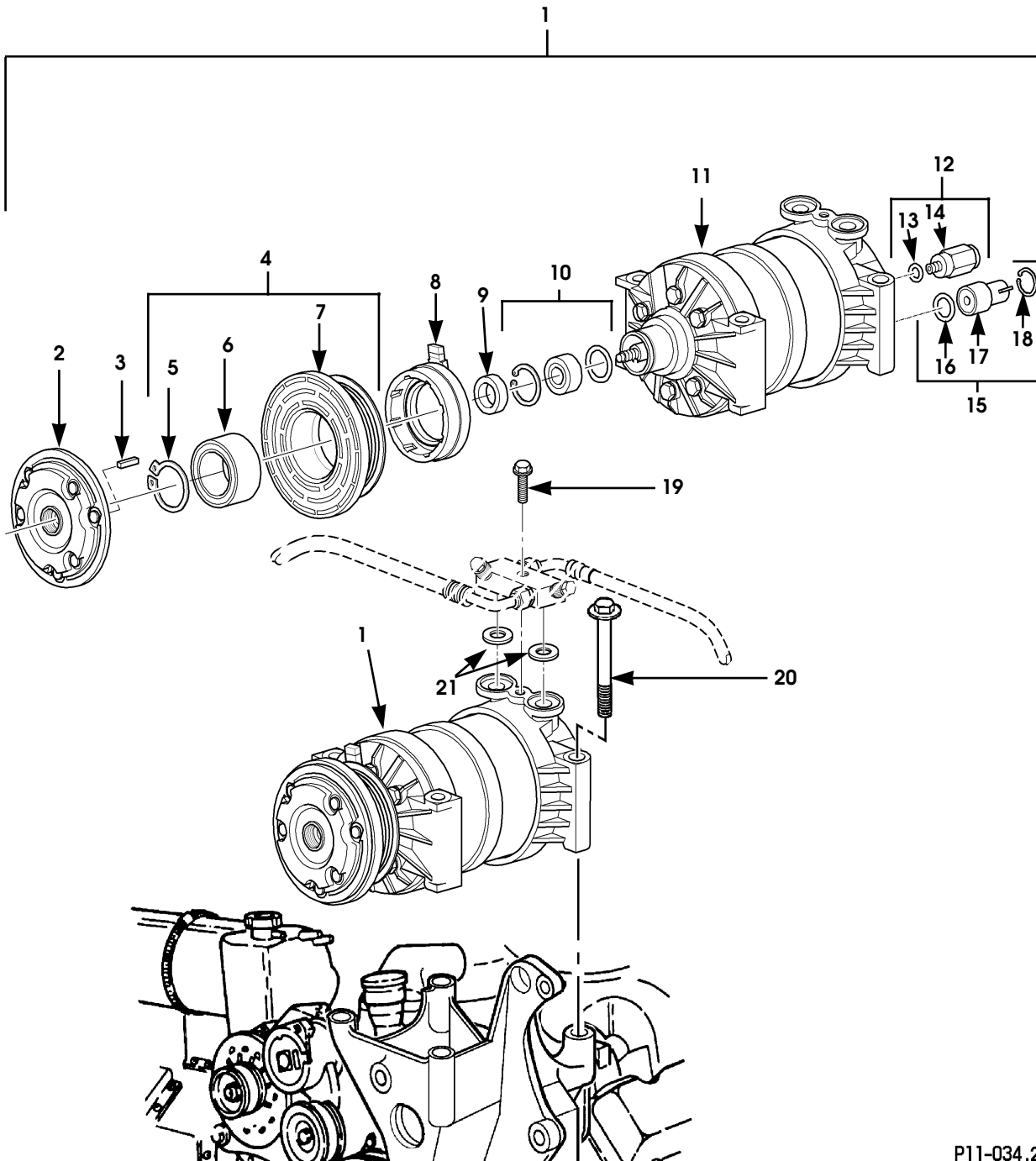

P11-034.2

Figure 11-2. A/C Compressor and Mounting Hardware.

# 2001 HUMMER PARTS CATALOG

## HEATING/VENTILATION/AIR CONDITIONING 11-5

ITEM	PART NUMBER	DESCRIPTION	QTY
		<b>Figure 11-2. A/C Compressor and Mounting Hardware.</b>	
1	6009795	COMPRESSOR ASSEMBLY, A/C .....	1
2	5744520	•CLUTCH DRIVE .....	1
3	5743077	•KEY, clutch drive .....	1
4	5744198	•PULLEY AND BEARING ASSEMBLY .....	1
5	5743075	••RETAINING RING .....	1
6	5743078	••BEARING, pulley .....	1
7	S.I.A.	••PULLEY .....	1
8	5744509	•COIL AND HOUSING ASSEMBLY .....	1
9	S.I.A.	•FELT WASHER .....	1
10	5743073	•SEAL KIT, lipseal .....	1
11	S.I.A.	•COMPRESSOR .....	1
12	5745118	•VALVE ASSEMBLY, pressure relief .....	1
13	S.I.A.	••O-RING .....	1
14	S.I.A.	••VALVE, pressure relief .....	1
15	5744865	•CUT-OFF SWITCH ASSEMBLY .....	1
16	S.I.A.	••O-RING .....	1
17	S.I.A.	••CUT-OFF SWITCH .....	1
18	S.I.A.	••RETAINER, snapping .....	1
19	6011914	BOLT .....	1
20	N/S	BOLT, M10-1.5 x 95, class 10.9 .....	4
21	6003079	WASHER, sealing, 5/8 .....	2
	5743547	OIL, Pag, 12 oz (not illustrated) .....	1



# 2001 HUMMER PARTS CATALOG

## 11-6 HEATING/VENTILATION/AIR CONDITIONING

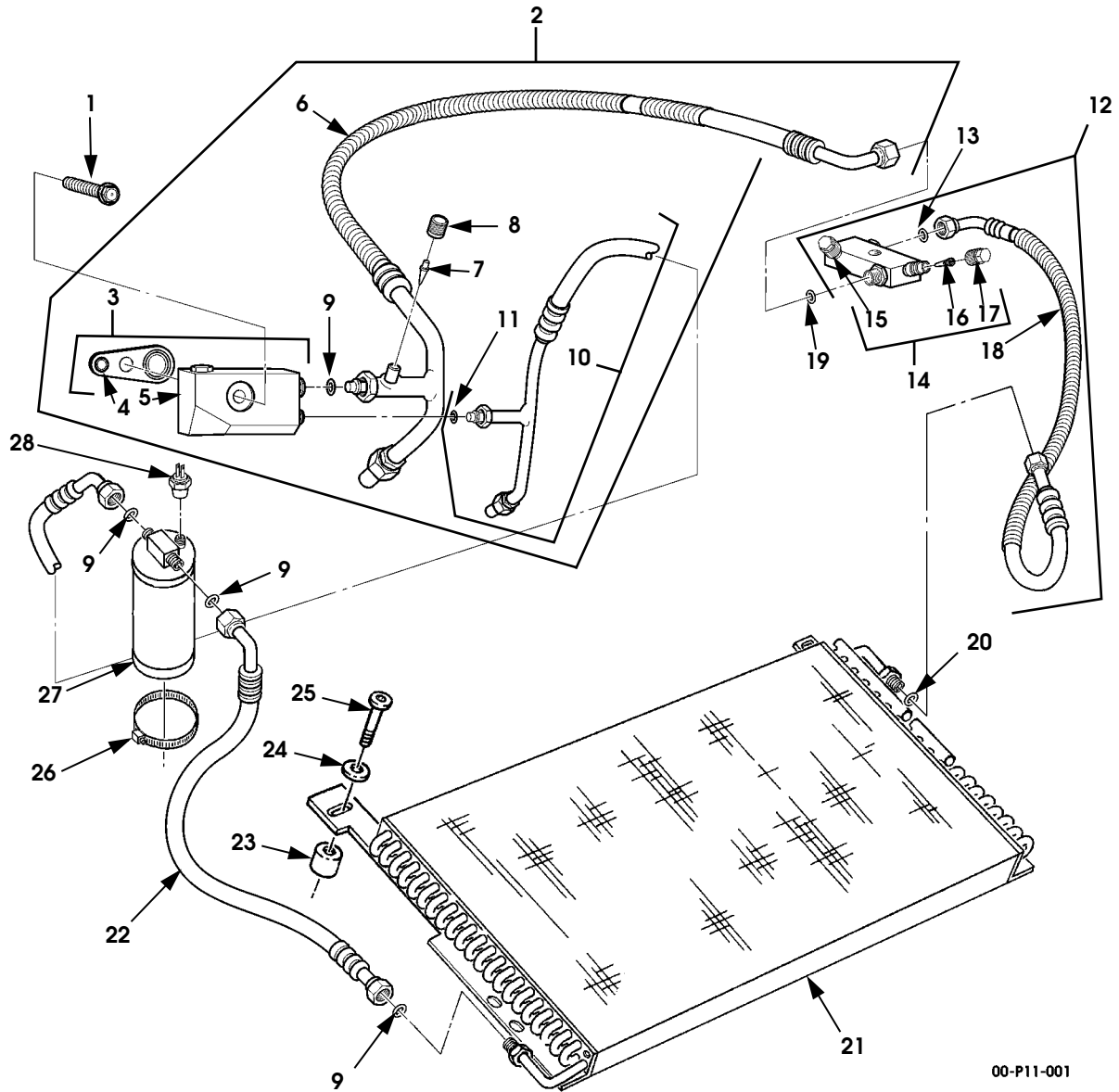

00-P11-001

Figure 11-3. Condenser, Receiver/Dryer, and A/C Hoses.

# 2001 HUMMER PARTS CATALOG

## HEATING/VENTILATION/AIR CONDITIONING 11-7

ITEM	PART NUMBER	DESCRIPTION	QTY
		<b>Figure 11-3. Condenser, Receiver/Dryer, and A/C Hoses.</b>	
1	N/S	CAPSCREW, M8 - 1.25 x 35 . . . . .	1
2	6011085	HOSE ASSEMBLY, A/C compressor-to-receiver/dryer . .	1
3	6011086	•BLOCK ASSEMBLY, manifold expansion . . . . .	1
4	5744825	•GASKET, block-to-expansion valve . . . . .	1
5	S.I.A.	•BLOCK, A/C manifold expansion . . . . .	1
6	6011087	•HOSE ASSEMBLY, A/C compressor-to-expansion valve . . . . .	1
7	5743824	•VALVE, schrader, small port . . . . .	1
8	5744902	•CAP, black, schrader valve . . . . .	1
9	6006173	•O-RING, #6, R-134a . . . . .	4
10	6011088	•HOSE, A/C manifold-to-receiver/dryer . . . . .	1
11	6006173	•O-RING, #6, R-134a . . . . .	1
12	6011089	HOSE ASSEMBLY, A/C discharge . . . . .	1
13	12341984-3	•O-RING, #10 . . . . .	1
14	6011090	•BLOCK ASSEMBLY, A/C . . . . .	1
15	5744843	•CAP, schrader valve, high side, red . . . . .	1
16	5744373	•VALVE, schrader, large port . . . . .	2
17	5744844	•CAP, schrader valve, low side, blue . . . . .	1
18	6011091	•HOSE ASSEMBLY, A/C compressor-to-condenser . . .	1
19	6008337	O-RING, #12, R-134a . . . . .	1
20	6006174	O-RING, #8, R-134a . . . . .	2
21	5744769	CONDENSER, A/C . . . . .	1
22	6008225	HOSE, #6, A/C condenser-to-receiver/dryer . . . . .	1
23	5743412	SPACER, A/C condenser . . . . .	4
24	N/S	WASHER, 5/16", flat . . . . .	4
25	5744143	SCREW, socket head . . . . .	4
26	5744142	CLAMP, 2 - 1/2", dryer . . . . .	2
27	5743473	RECEIVER/DRYER, A/C . . . . .	1
28	6011092	SWITCH, low pressure cut-out . . . . .	1

# 2001 HUMMER PARTS CATALOG

## 11-8 HEATING/VENTILATION/AIR CONDITIONING

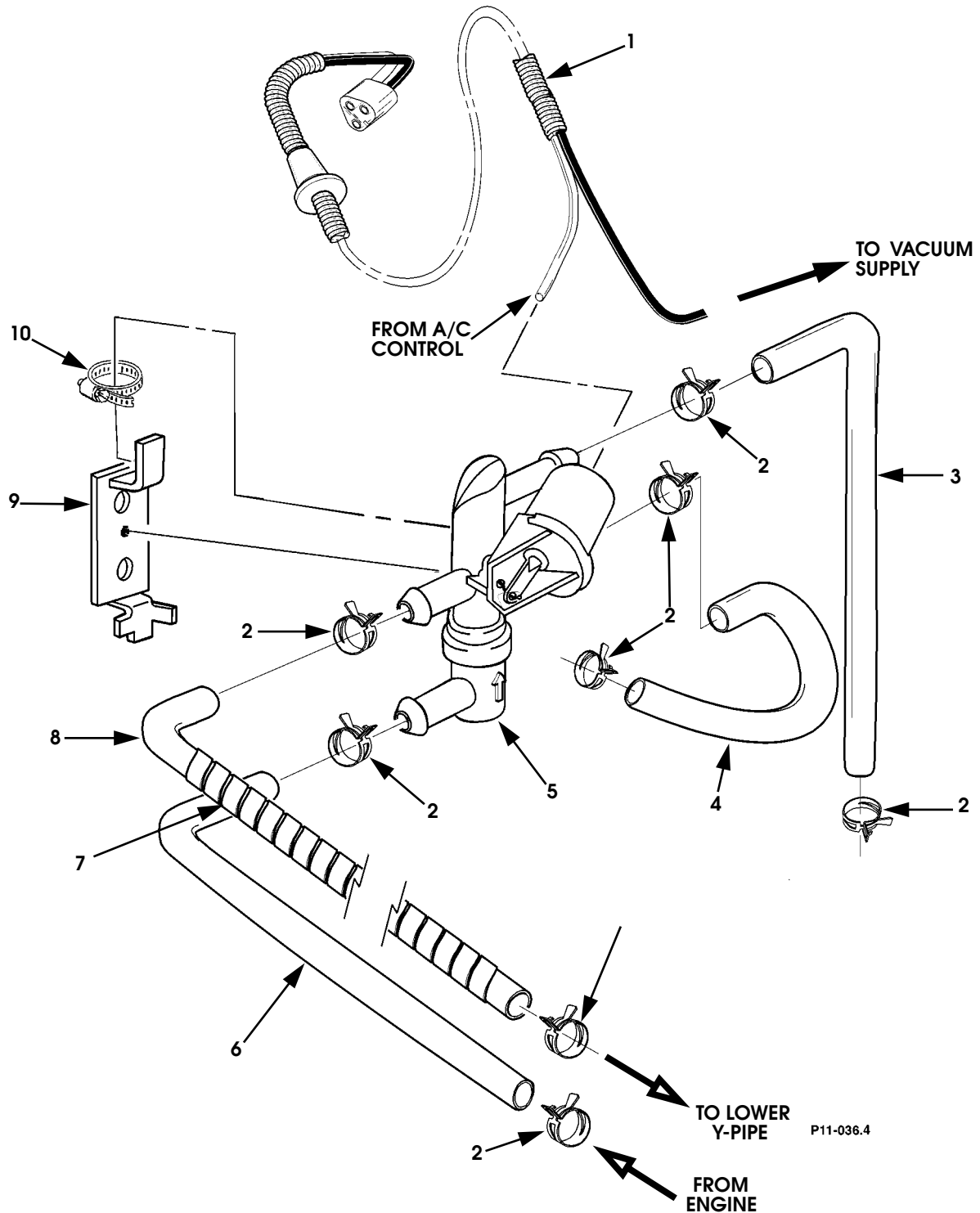

Figure 11-4. Water Control Valve and Heater Hoses.

# 2001 HUMMER PARTS CATALOG

## HEATING/VENTILATION/AIR CONDITIONING 11-9

ITEM	PART NUMBER	DESCRIPTION	QTY
		<b>Figure 11-4. Water Control Valve and Heater Hoses.</b>	
1	5744794	VACUUM HARNESS, water valve .....	1
2	5743508	CLAMP, hose, 24mm, constant tension .....	8
3	6006271	HOSE, heater molded, 90 degrees SEE NOTE 1 .....	1
4	6006268	HOSE, heater, molded, 270 degrees, .....	1
5	5744563	VALVE, water control. ....	1
6	6006271	HOSE, heater, molded, 90 degrees, SEE NOTE 1 .....	1
7	6004436	SPIRAL CHAFE GUARD. ....	1
8	6006270	HOSE, heater, to lower y-pipe .....	1
9	6007368B9	BRACKET, water valve mounting .....	1
10	N/S	CLAMP, #10 - #11 .....	1
		 NOTE 1: CUT TO REQUIRED LENGTH.	

# 2001 HUMMER PARTS CATALOG

## 11-10 HEATING/VENTILATION/AIR CONDITIONING

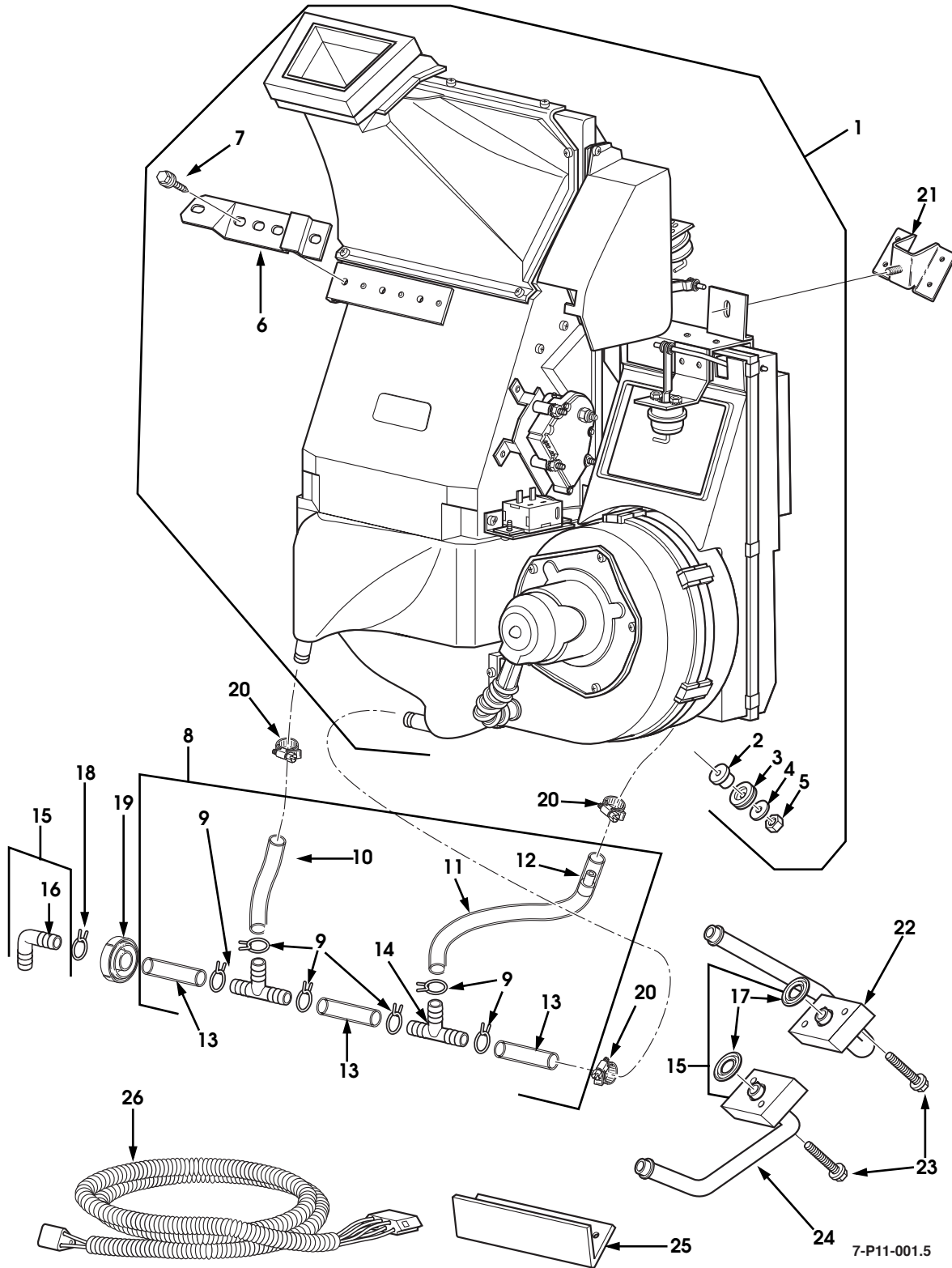

Figure 11-5. Main A/C-Heat Unit.

# 2001 HUMMER PARTS CATALOG

## HEATING/VENTILATION/AIR CONDITIONING 11-11

ITEM	PART NUMBER	DESCRIPTION	QTY
		<b>Figure 11-5. Main A/C-Heat Unit.</b>	
1	6009308	HVAC ASSEMBLY, main unit . . . . .	1
2	5744785	•BUSHING, mounting plate sealing . . . . .	2
3	S.I.A.	•GROMMET, firewall . . . . .	2
4	S.I.A.	•WASHER, .275 I.D., fender . . . . .	2
5	S.I.A.	•NUT, 1/4 - 20, keps, ZN . . . . .	2
6	S.I.A.	•BRACKET, inboard mounting . . . . .	1
7	S.I.A.	•BOLT, 1/4 - 20 x 7/8, w/hex washer . . . . .	2
8	6010854	DRAIN HOSE KIT . . . . .	1
9	S.I.K.	•CLAMP, constant tension, 1/2", drain . . . . .	6
10	S.I.K.	•TUBE, drain, intermediate, short . . . . .	1
11	6009746	•TUBE ASSEMBLY, drain, intermediate, long . . . . .	1
12	S.I.A.	••FLOW RESTRICTOR . . . . .	1
13	S.I.K.	•TUBE, drain, 1/2" . . . . .	3
14	N/S	•TEE-FITTING, 1/2" . . . . .	2
15	6010855	ACCESSORY KIT, main HVAC unit . . . . .	1
16	S.I.K.	•ELBOW, 90-degree, 1/2", drain tube . . . . .	1
17	5744774	•GASKET, heater tube . . . . .	2
	S.I.K.	•HARDWARE BAG, additional (not illustrated) . . . . .	1
18	N/S	CLAMP, constant tension, 1/2", drain . . . . .	1
19	6000946	GROMMET, cowl drain hose . . . . .	1
20	N/S	CLAMP, worm gear type, 1/2", drain . . . . .	3
21	6009440B9	BRACKET, HVAC mounting, upper, SEE NOTE 1 . . . . .	1
22	5744808	TUBE, heater, upper . . . . .	1
23	N/S	BOLT, flanged, 1/4 - 20 x 1 1/4 . . . . .	4
24	5744809	TUBE, heater, lower . . . . .	1
25	6009384B9	BRACKET, HVAC mounting, lower, SEE NOTE 1 . . . . .	1
26	5744792	HARNES, control, vacuum . . . . .	1
	5745370	KIT, nipple repair (not illustrated) . . . . .	1
		 NOTE 1: PART OF BODY, NOT PART OF HVAC UNIT.	

# 2001 HUMMER PARTS CATALOG

## 11-12 HEATING/VENTILATION/AIR CONDITIONING

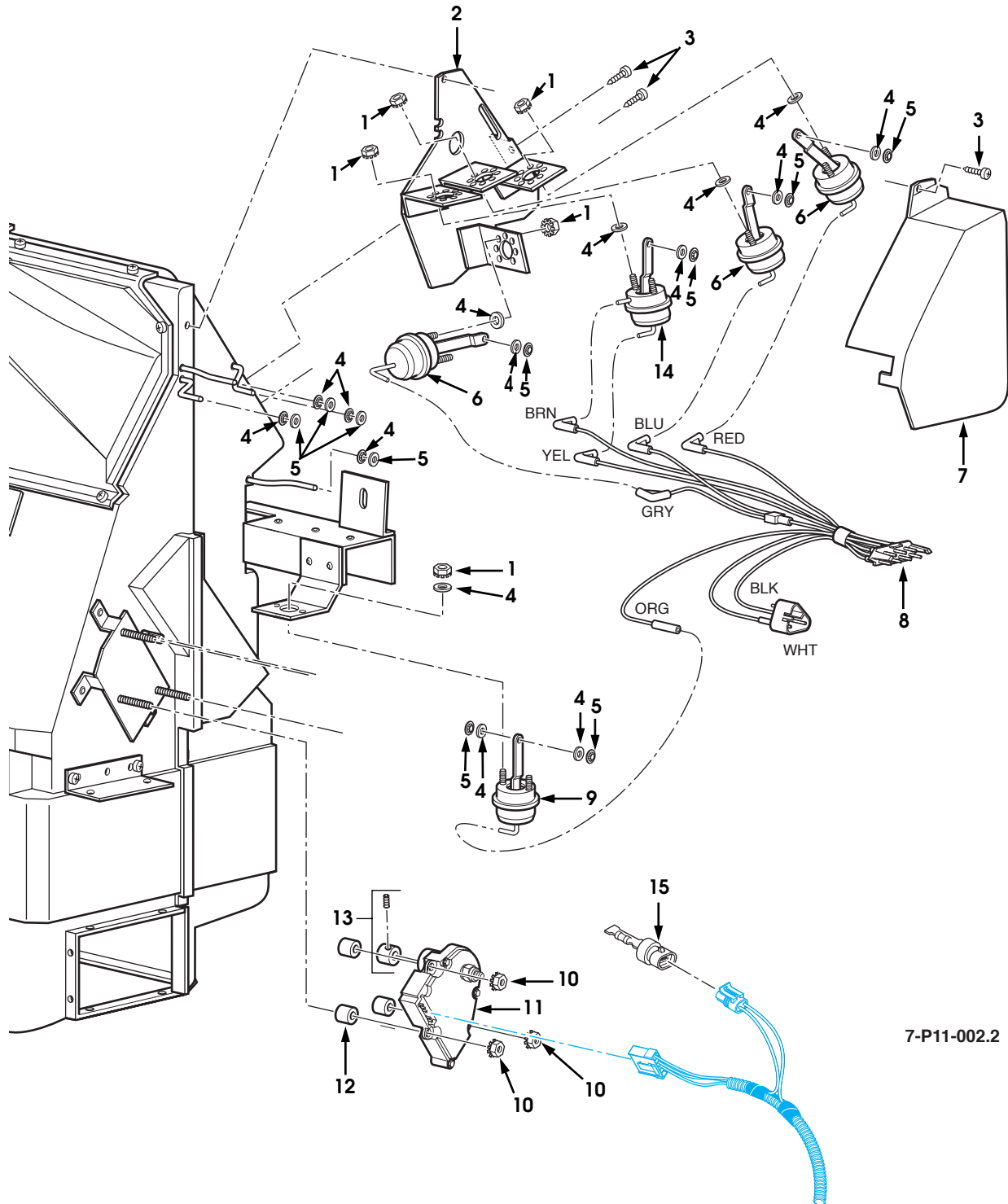

7-P11-002.2

Figure 11-6. A/C-Heat Vacuum and Temperature Door Motors.

# 2001 HUMMER PARTS CATALOG

## HEATING/VENTILATION/AIR CONDITIONING 11-13

ITEM	PART NUMBER	DESCRIPTION	QTY
		<b>Figure 11-6.</b> <b>A/C-Heat Vacuum and Temperature Door Motors.</b>	
1	N/S	NUT, KEPS 10-24, ZN, SEE NOTE 1 . . . . .	10
2	5744786	MOUNTING PLATE, vacuum motor . . . . .	1
3	N/S	SCREW, phcr, #8 - 32 x 1/2 . . . . .	5
4	N/S	WASHER, 5mm, flat , Silver/Zinc DIN125A, SEE NOTE 2 . .	20
5	5743459	PUSH NUT, 3/16" SEE NOTE 1 . . . . .	10
6	5744761	MOTOR, vacuum . . . . .	3
7	5744810	COVER, vacuum motor . . . . .	1
8	5744790	HARNESS, vacuum evaporator . . . . .	1
9	5744762	MOTOR, vacuum . . . . .	3
10	N/S	NUT, #10 - 32, keps . . . . .	3
11	5744764	MOTOR, temperature door . . . . .	1
12	N/S	SPACER, 1/2" , nylon . . . . .	3
13	5744784	COUPLER, temperature door motor . . . . .	1
14	5744763	MOTOR, vacuum . . . . .	1
15	6010396	RESISTOR MODULE, temperature door . . . . .	1
		NOTE 1: TWO PER ITEM NUMBERS 6, 9, AND 14.	
		NOTE 2: FOUR PER ITEM NUMBERS 6, 9, AND 14.	



# 2001 HUMMER PARTS CATALOG

## 11-14 HEATING/VENTILATION/AIR CONDITIONING

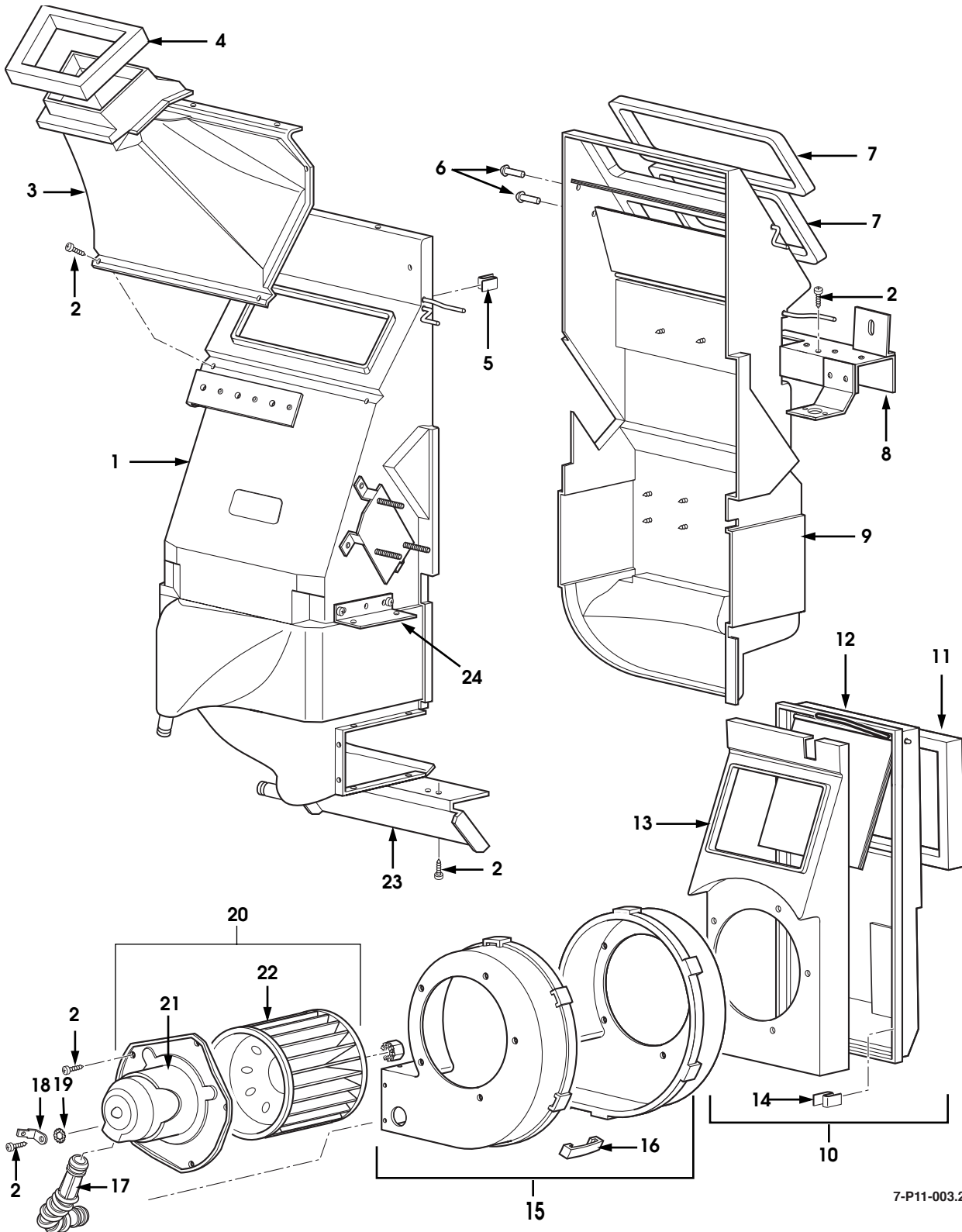

7-P11-003.2

Figure 11-7. Main A/C-Heat Case Halves and Blower Motor.

# 2001 HUMMER PARTS CATALOG

## HEATING/VENTILATION/AIR CONDITIONING 11-15

ITEM	PART NUMBER	DESCRIPTION	QTY
		<b>Figure 11-7. Main A/C-Heat Case Halves and Blower Motor.</b>	
1	5744777	LOWER CASE ASSEMBLY . . . . .	1
2	N/S	SCREW, 8 x 1/2 pan head, Phil. . . . .	17
3	5744791	TRANSITION ASSEMBLY. . . . .	1
4	N/S	SEAL, foam . . . . .	4
5	5743478	S-CLIP,blower housing. . . . .	6
6	5743462	RIVET, 1/4" grip . . . . .	2
7	N/S	SEAL, foam . . . . .	2
8	N/S	BRACKET, mounting, air intake housing assembly . . . .	1
9	5744782	UPPER CASE ASSEMBLY . . . . .	1
10	5744781	AIR INTAKE HOUSING ASSEMBLY . . . . .	1
11	N/S	•SEAL, foam . . . . .	1
12	5744778	•HOUSING, upper air intake. . . . .	1
13	5744779	•HOUSING, lower air intake . . . . .	1
14	5743478	•S-Clip . . . . .	5
15	5744776	BLOWER HOUSING. . . . .	1
16	S.I.A.	•CLIP,blower housing . . . . .	5
17	5743484	TUBE, motor cooling . . . . .	1
18	5743526	CLIP,ground connection . . . . .	1
19	N/S	WASHER, double tooth star . . . . .	1
20	5744766	BLOWER MOTOR ASSEMBLY . . . . .	1
21	N/S	•BLOWER MOTOR, main HVAC unit . . . . .	1
22	5745117	•WHEEL, blower motor . . . . .	1
23	N/S	BRACKET, mounting, blower motor . . . . .	1
24	N/S	BRACKET, mounting, thermostat . . . . .	1

# 2001 HUMMER PARTS CATALOG

## 11-16 HEATING/VENTILATION/AIR CONDITIONING

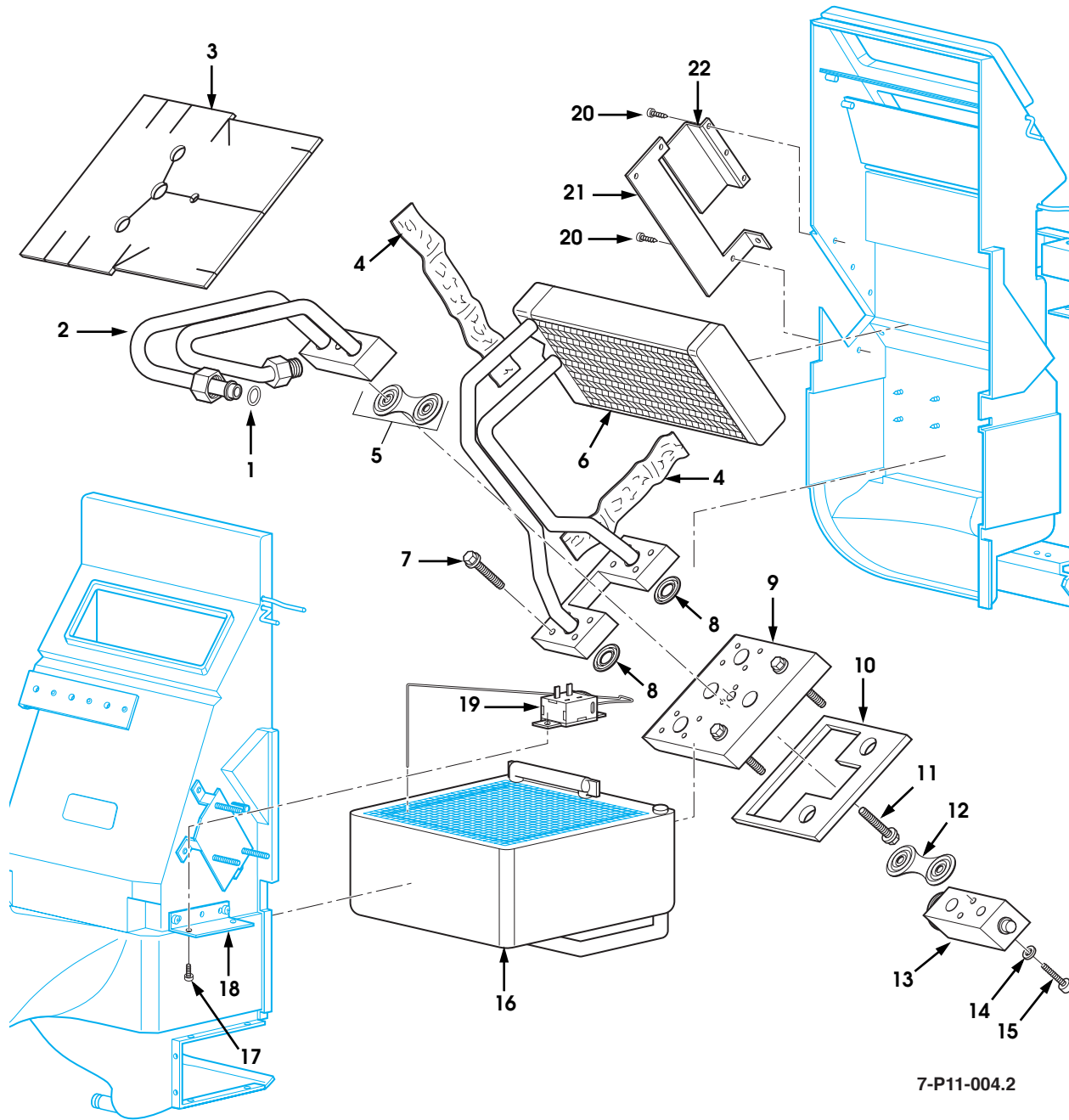

Figure 11-8. Main A/C-Heat Evaporator and Heater Core Assemblies.

# 2001 HUMMER PARTS CATALOG

## HEATING/VENTILATION/AIR CONDITIONING 11-17

ITEM	PART NUMBER	DESCRIPTION	QTY
		<b>Figure 11-8. Main A/C-Heat Evaporator and Heater Core Assemblies.</b>	
1	6006174	O-RING, #8 . . . . .	1
2	5744771	MANIFOLD FITTING . . . . .	1
3	5744904	INSULATION, sealing plate . . . . .	1
4	5743167	TAPE, sealant . . . . .	2
5	5744773	GASKET, manifold to evaporator SEE NOTE 1 . . . . .	11
6	5744783	HEATER CORE. . . . .	1
7	N/S	BOLT, flanged, 1/4 - 20 x 1 1/4 . . . . .	4
8	5744774	GASKET, heater hose adapter . . . . .	4
9	5744772	SEALING PLATE, footwell opening . . . . .	1
10	5744780	MOUNTING PLATE, insulation/seal . . . . .	1
11	N/S	BOLT, socket head, 1/4 - 20. . . . .	2
12	5744775	GASKET, expansion valve to block . . . . .	1
13	5744770	VALVE, expansion . . . . .	1
14	N/S	WASHER, 1/4 . . . . .	1
15	5744767	BOLT, torx head, expansion valve mounting . . . . .	2
16	5744768	EVAPORATOR COIL ASSEMBLY . . . . .	1
17	N/S	SCREW, phcr, M5 x 0.80 - 8 . . . . .	2
18	N/S	BRACKET, mounting, thermostat . . . . .	1
19	5744760	THERMOSTAT, 34-39 degrees. . . . .	1
20	N/S	SCREW, phcr, #8 - 32 x 1/2. . . . .	6
21	N/S	PLATE, heater edge support , part of upper case assembly . . . . .	1
22	N/S	BRACKET, heater cap, part of upper case assembly . . . . .	1
		 NOTE 1: CUT APART TO ACCOMMODATE BOLT.	

# 2001 HUMMER PARTS CATALOG

## 11-18 HEATING/VENTILATION/AIR CONDITIONING

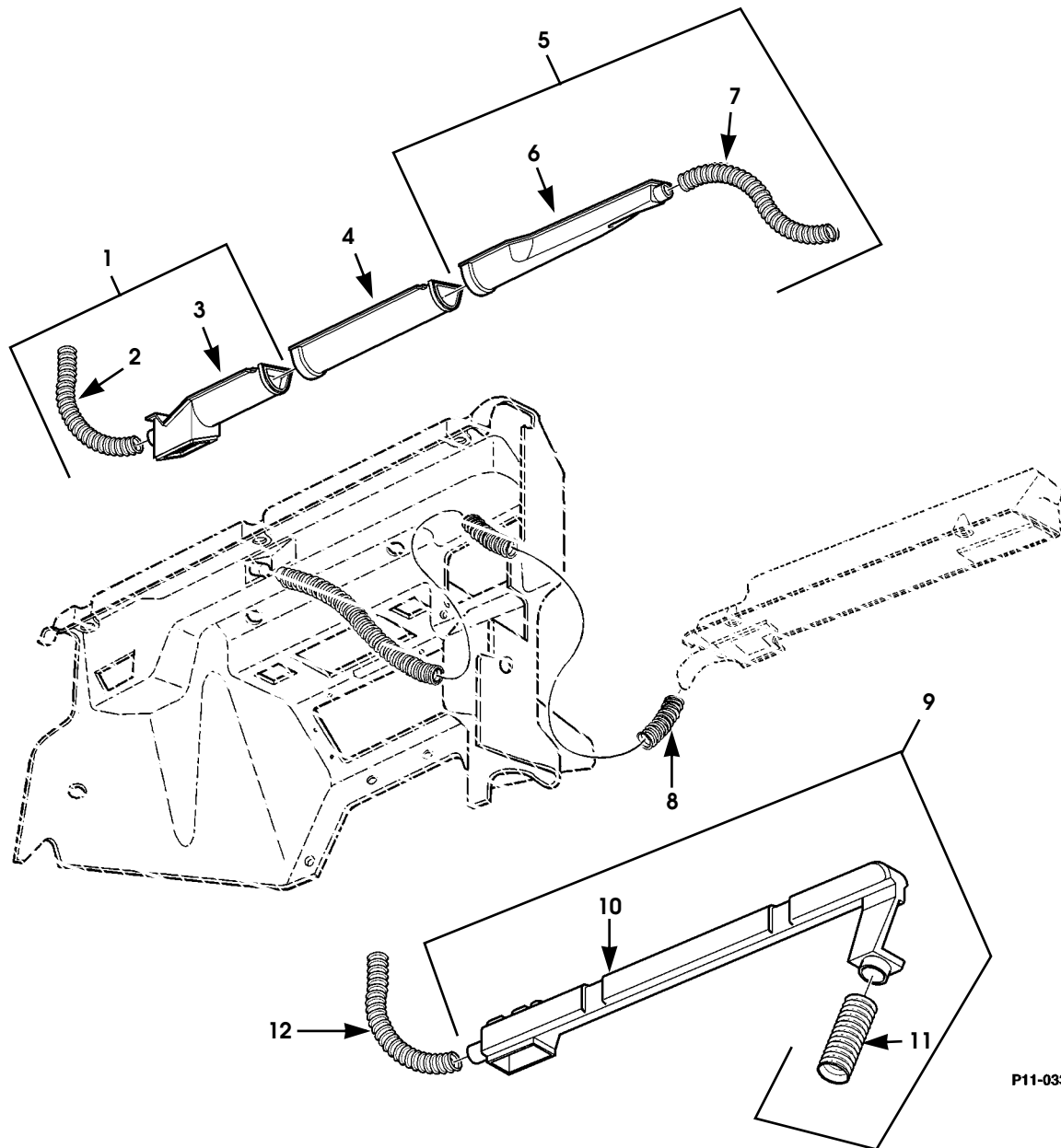

P11-033.3

Figure 11-9. Plenum and Related Parts.

# 2001 HUMMER PARTS CATALOG

## HEATING/VENTILATION/AIR CONDITIONING 11-19

ITEM	PART NUMBER	DESCRIPTION	QTY
		<b>Figure 11-9. Plenum and Related Parts.</b>	
1	5744939	DUCT ASSEMBLY, passenger side . . . . .	1
2	5744258	•HOSE, 3/4" I.D. x 18", demist, SEE NOTE 1 . . . . .	1
3	S.I.A.	•DUCT, passenger side . . . . .	1
4	5744940	DUCT, center . . . . .	1
5	5745394	DUCT ASSEMBLY, driver's side . . . . .	1
6	S.I.A.	•DUCT, driver's side . . . . .	1
7	5744258	•HOSE, 3/4" I.D. x 18", demist, SEE NOTE 1 . . . . .	1
8	N/S	HOSE, 1.5" I.D. x 19", driver's side dash pad, SEE NOTE 2 .	1
9	5745396	DUCT ASSEMBLY, driver's and front passenger's footwell	1
10	S.I.A.	•DUCT, driver's and passenger's footwells . . . . .	1
7	S.I.A.	•HOSE, 2.5" I.D. x 6", driver's footwell, SEE NOTE 3 . . . .	1
8	N/S	HOSE, 2" I.D. x 28", front passenger's footwell, SEE NOTE 4	1
		NOTE 1: CUT FROM BULK HOSE P/N 5743540.	
		NOTE 2: CUT FROM BULK HOSE P/N 5743541, OR CUT FROM HOSE, P/N 5743588.	
		NOTE 3: CUT FROM BULK HOSE P/N 5743023.	
		NOTE 4: PART OF DASH KIT P/N 6009548, OR CUT FROM BULK HOSE P/N 5743542.	

# 2001 HUMMER PARTS CATALOG

## 11-20 HEATING/VENTILATION/AIR CONDITIONING

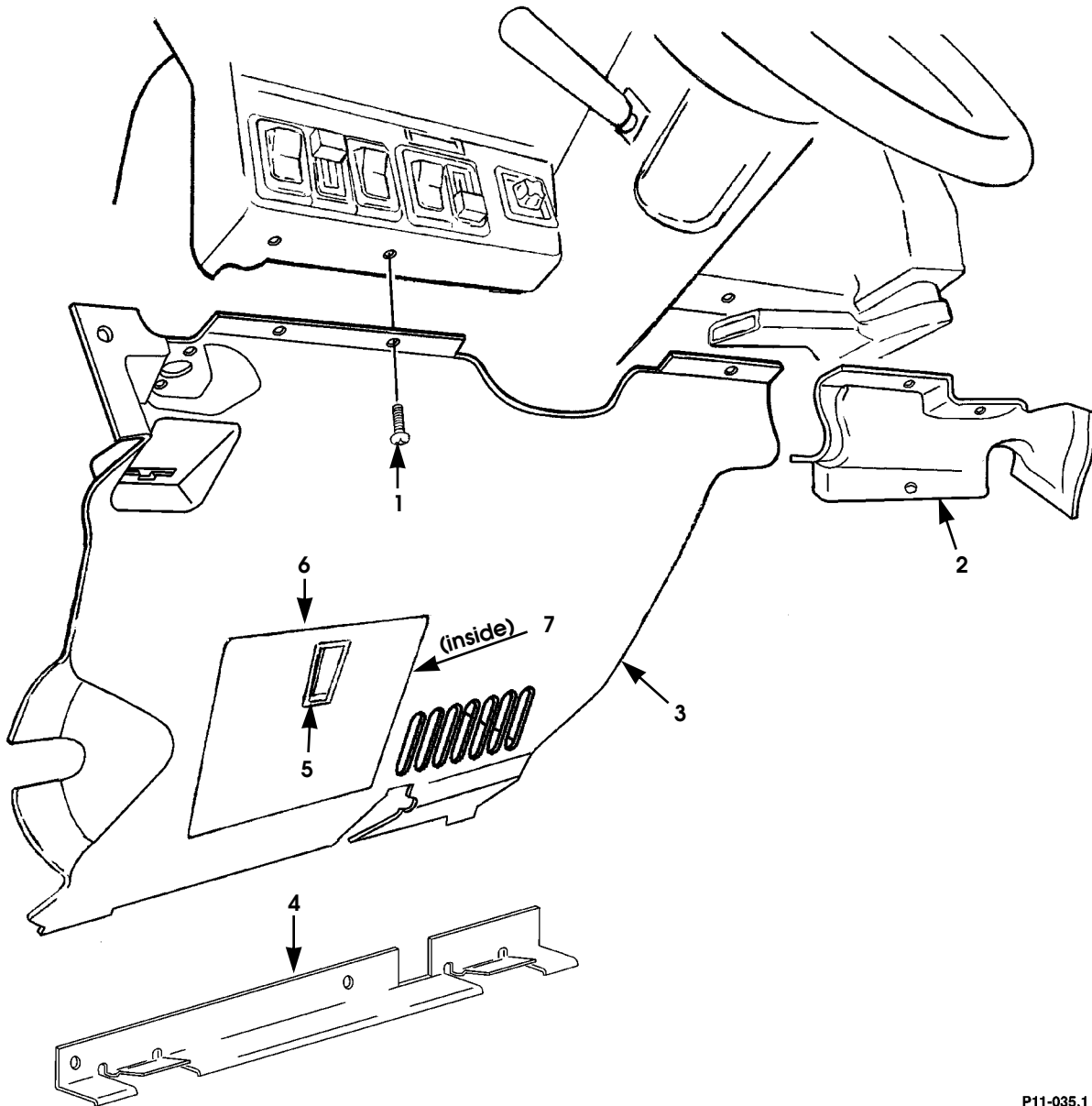

P11-035.1

Figure 11-10. Closeout Panel, Driver's.

# 2001 HUMMER PARTS CATALOG

## HEATING/VENTILATION/AIR CONDITIONING 11-21

ITEM	PART NUMBER	DESCRIPTION	QTY
		<b>Figure 11-10. Closeout Panel, Driver's.</b>	
1	6005624	SCREW, trim, #8 -18 x 1 . . . . .	10
2	6006970	COVER, I/P harness . . . . .	1
3	6008757	PANEL, closeout . . . . .	1
4	6005497	•BRACKET, closeout panel . . . . .	1
5	6007240	•LATCH, closeout panel door . . . . .	1
6	6006973	•DOOR, closeout panel . . . . .	1
7	6010697	DECAL ASSEMBLY, fuse box . . . . .	1
8	6010694	COVER, DLC test connector (not illustrated) . . . . .	1



# 2001 HUMMER PARTS CATALOG

## 11-22 HEATING/VENTILATION/AIR CONDITIONING

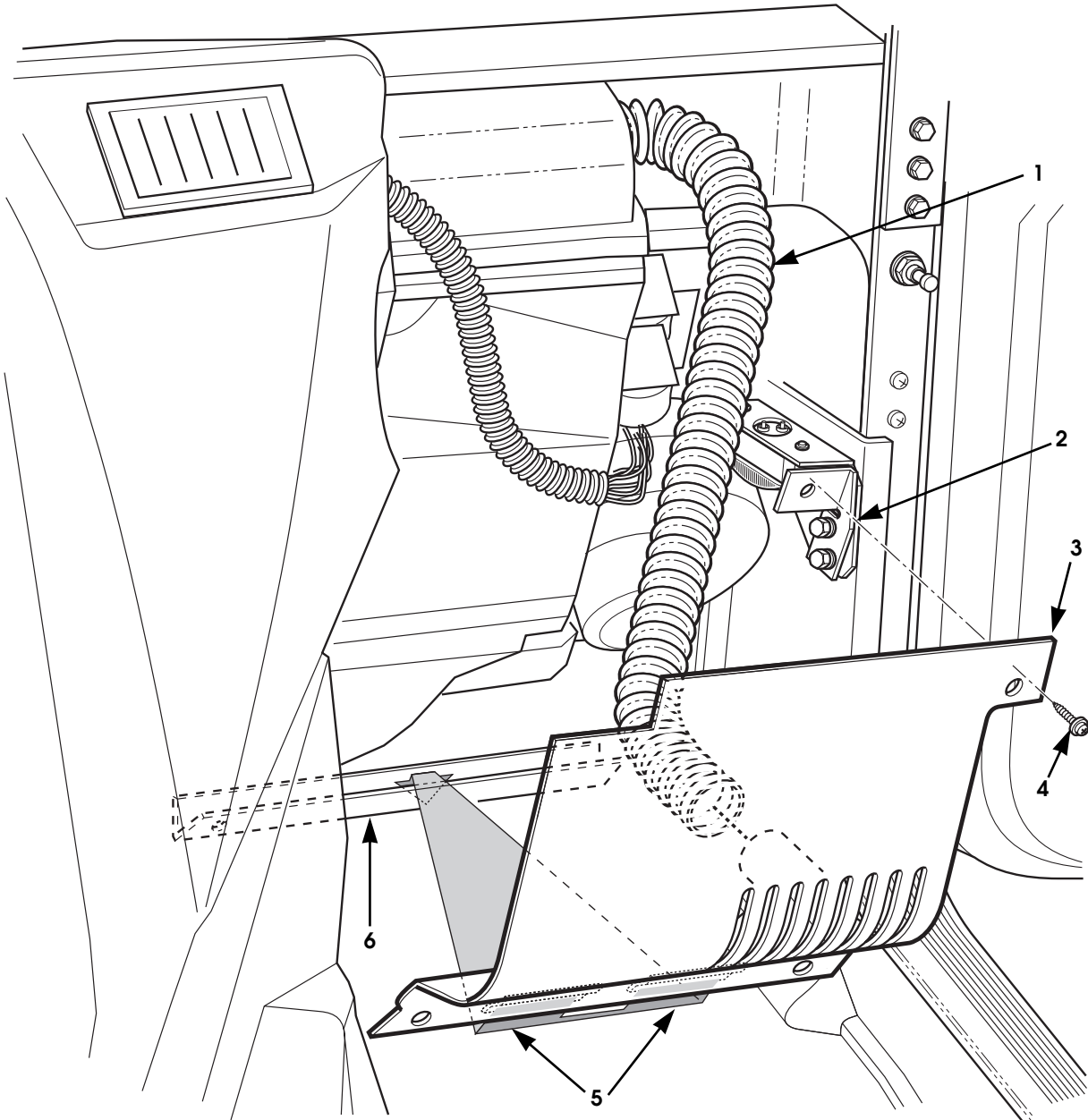

Figure 11-11. Closeout Panel, Passenger's.

# 2001 HUMMER PARTS CATALOG

## HEATING/VENTILATION/AIR CONDITIONING 11-23

ITEM	PART NUMBER	DESCRIPTION	QTY
		<b>Figure 11-11. Closeout Panel, Passenger's.</b>	
1	N/S	FLEXIBLE DUCT, 2" ID x 42", to passenger's foot vent, SEE NOTE 1 . . . . .	1
2	6009524B9	BRACKET, upper closeout panel . . . . .	1
3	6009520	PASSENGER'S CLOSEOUT PANEL . . . . .	1
4	6000243	SCREW, tapping, trim. . . . .	1
5	6007191	BRACKET, crash pad mounting . . . . .	2
6	6009525B9	BRACKET, lower closeout panel mounting . . . . .	1
		 NOTE 1: CUT FROM BULK HOSE P/N 5743542	

# 2001 HUMMER PARTS CATALOG

## 11-24 HEATING/VENTILATION/AIR CONDITIONING

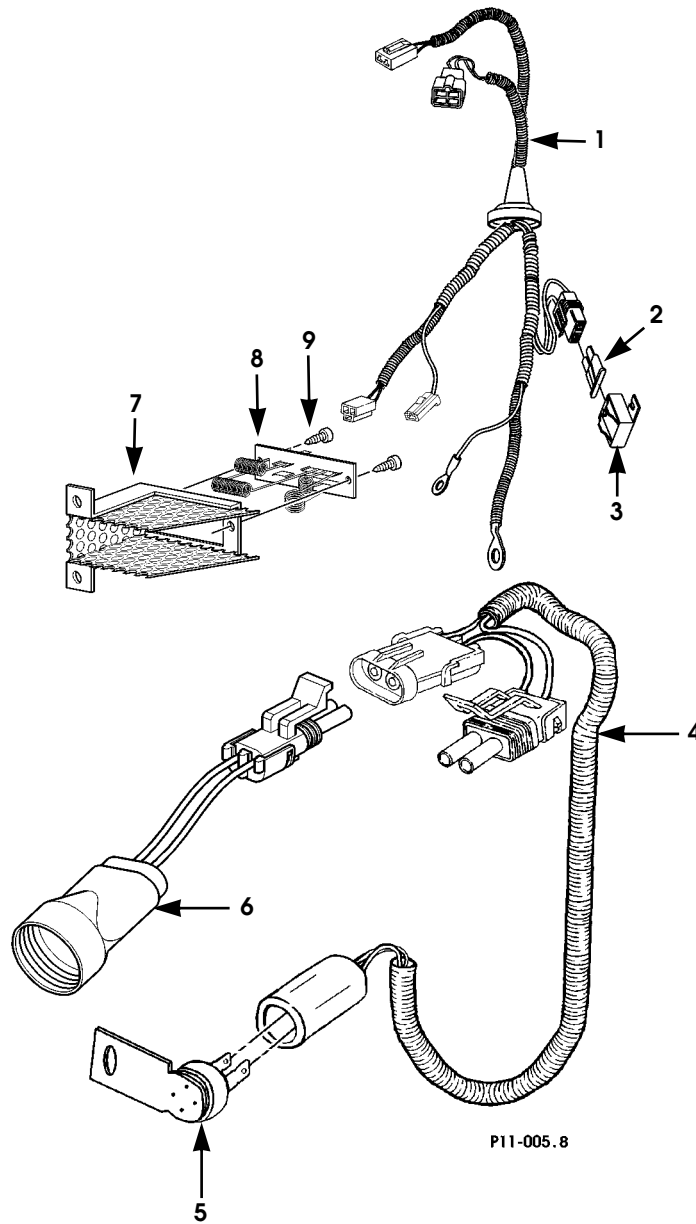

Figure 11-12. Wiring Harnesses, A/C-Heat.

# 2001 HUMMER PARTS CATALOG

## HEATING/VENTILATION/AIR CONDITIONING 11-25

ITEM	PART NUMBER	DESCRIPTION	QTY
		<b>Figure 11-12. Wiring Harnesses, A/C-Heat.</b>	
1	6009304	HARNESS ASSEMBLY , engine compartment. . . . .	1
2	5939408	•FUSE, 30-amp . . . . .	1
3	6000023	•COVER, 30-amp fuse . . . . .	1
4	5743468	HARNESS, ambient temperature switch . . . . .	1
5	5743469	•SWITCH, ambient temperature . . . . .	1
6	5743767	JUMPER, low pressure switch . . . . .	1
7	6009439B9	BRACKET, blower resistor mounting . . . . .	1
8	6009438	RESISTOR, HVAC blower. . . . .	1
9	N/S	SCREW, tapping, #10 - 24 x 1/4. . . . .	2

# 2001 HUMMER PARTS CATALOG

## 11-26 HEATING/VENTILATION/AIR CONDITIONING

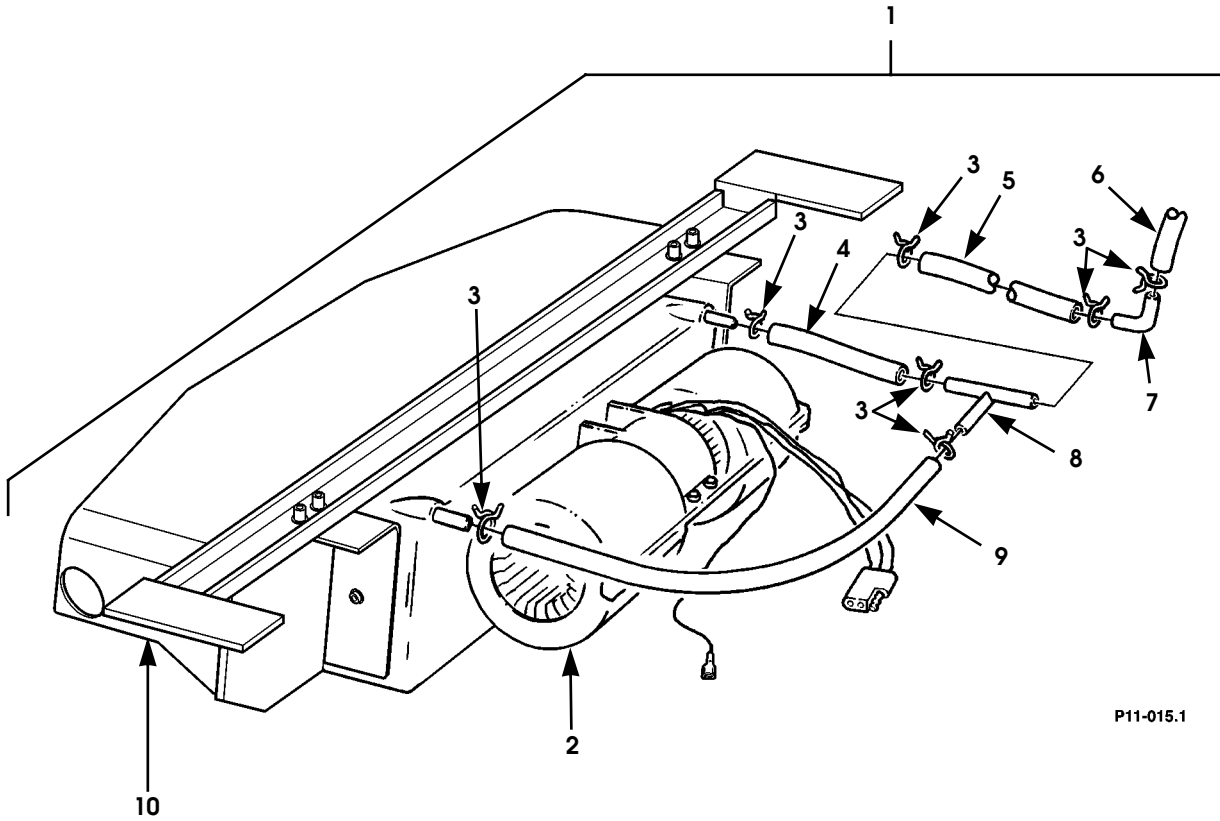

Figure 11-13. Auxiliary A/C-Heat.

# 2001 HUMMER PARTS CATALOG

## HEATING/VENTILATION/AIR CONDITIONING 11-27

ITEM	PART NUMBER	DESCRIPTION	QTY
		<b>Figure 11-13. Auxiliary A/C-Heat.</b>	
1	6009414	KIT, auxiliary A/C-Heat .....	1
2	5744788	•HEAT/COOL POWER, heavy duty, .....	1
3	5743172	••CLAMP, hose, 3/8" .....	7
4	5743582	••HOSE, drain, 3/8" x 5", SEE NOTE 1 .....	1
5	5743586	••HOSE, drain, 3/8" x 13", SEE NOTE 1 .....	1
6	5743587	••HOSE, drain 3/8" x 15", SEE NOTE 1 .....	1
7	5743170	••ELBOW, drain hose, 3/8" .....	1
8	5743171	••TEE, drain, 3/8" .....	1
9	5743583	••HOSE, drain, 3/8" x 17", SEE NOTE 1 .....	1
10	5744765	•PLENUM, auxiliary HVAC .....	1
		NOTE 1: CUT FROM HOSE 3/8" X 4', P/N 5743169, OR FROM BULK HOSE 3.8" X 50', P/N 5743584.	

# 2001 HUMMER PARTS CATALOG

## 11-28 HEATING/VENTILATION/AIR CONDITIONING

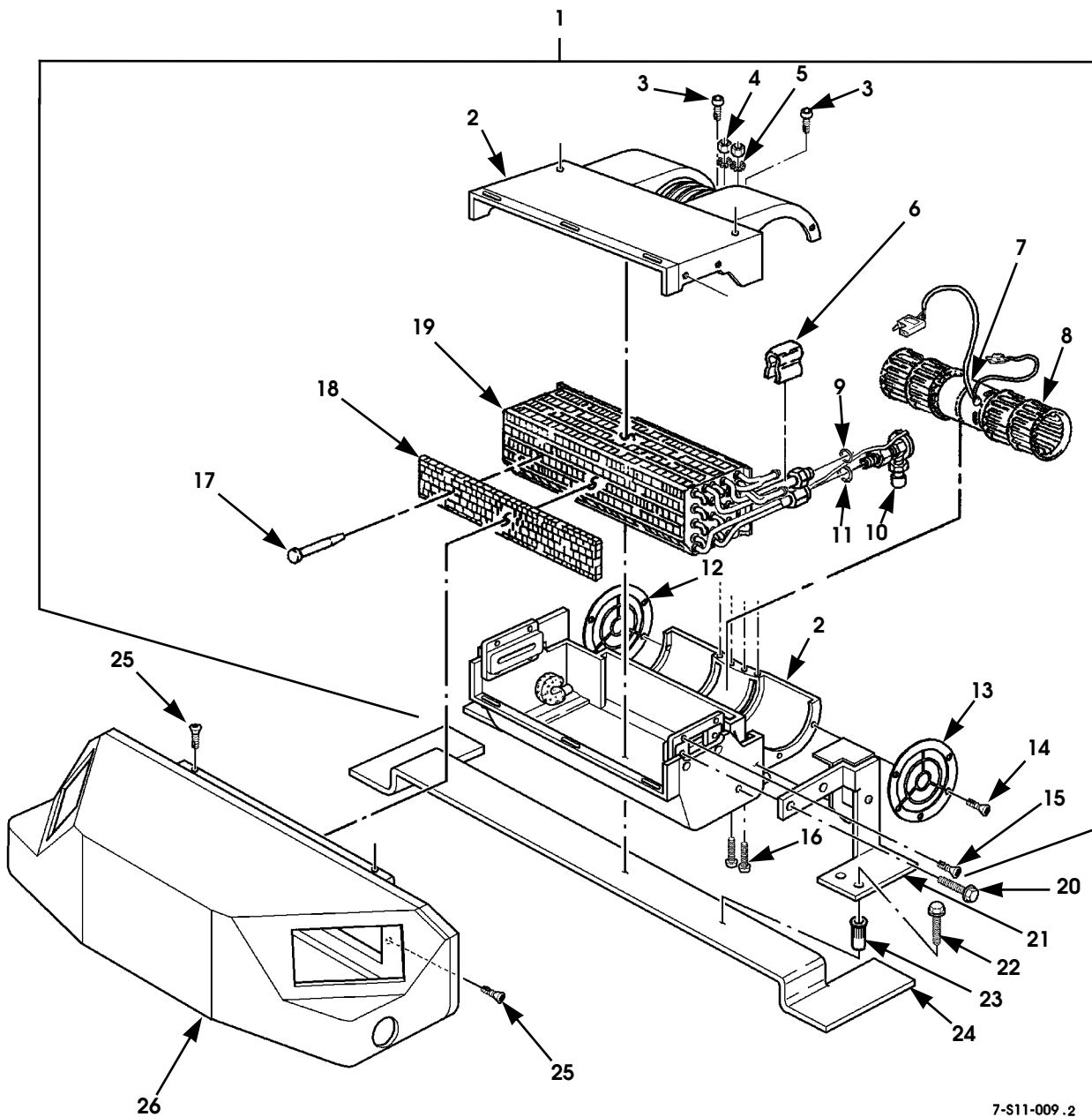

7-S11-009 .2

Figure 11-14. Auxiliary HVAC Unit.

# 2001 HUMMER PARTS CATALOG

## HEATING/VENTILATION/AIR CONDITIONING 11-29

ITEM	PART NUMBER	DESCRIPTION	QTY
		<b>Figure 11-14. Auxiliary HVAC Unit.</b>	
1	5744788	AUXILIARY A/C-HEAT POWER HEAD ASSEMBLY . . . . .	1
2	5745033	•CASE, top and bottom . . . . .	1
3	S.I.A.	•SCREW, tapping, #10 - 16 x 5/8. . . . .	2
4	S.I.A.	•NUT . . . . .	2
5	S.I.A.	•LOCKWASHER, external tooth . . . . .	2
6	5743453	•CLAMP, bulb . . . . .	1
7	5743497	•MOTOR, blower . . . . .	1
8	5743498	•WHEEL, blower . . . . .	1
9	6006175	•O-RING, #10 . . . . .	1
10	5743496	•VALVE, expansion, auxiliary HVAC, R134a. . . . .	1
11	6006174	•O-RING, #8 . . . . .	1
12	S.I.A.	•END GUARD, auxiliary blower wheel, L.H. . . . .	1
13	S.I.A.	•END GUARD, auxiliary blower wheel, R.H. . . . .	1
14	S.I.A.	•SCREW, countersunk, cr . . . . .	8
15	S.I.A.	•SCREW, tapping, countersunk, cr. . . . .	4
16	S.I.A.	•BOLT, #10 - 24 x 3/4 . . . . .	2
17	5744196	PIN, insulation. . . . .	3
18	5744195	SCREEN, coil . . . . .	1
19	5744894	COIL, evaporator and heater . . . . .	1
20	5744236	SCREW, 1/4 - 20 x 1/2. . . . .	2
21	N/S	BRACKET, left, aux. A/C mounting, SEE NOTE 1 . . . . .	1
21	N/S	BRACKET, right, aux. A/C mounting, SEE NOTE 1 . . . . .	1
22	N/S	SCREW, 1/4 - 20 x 1/2. . . . .	8
23	N/S	NUT INSERT, 1/4 - 20 . . . . .	4
24	5743534	BRACKET, aux. A/C mounting. . . . .	1
25	N/S	SCREW, tapping, #6 - 32 x 3/8, plenum-to-powerhead	4
26	5744765	PLENUM, rear . . . . .	1
NOTE 1: MOUNTING BRACKETS COME WITH AUXILIARY HVAC KIT, 6009414.			



# 2001 HUMMER PARTS CATALOG

## 11-30 HEATING/VENTILATION/AIR CONDITIONING

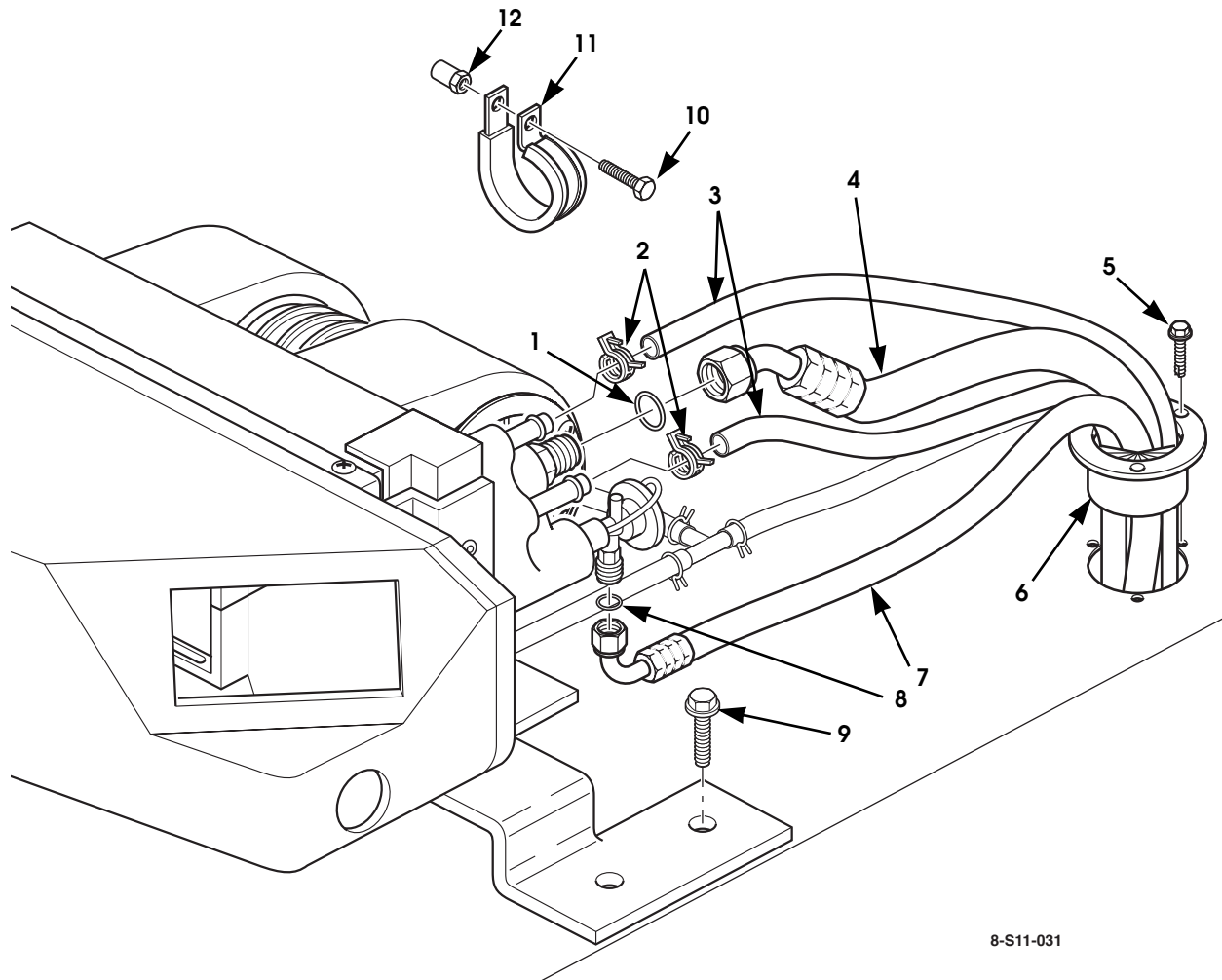

8-S11-031

Figure 11-15. Auxiliary A/C-Heat Hoses.

# 2001 HUMMER PARTS CATALOG

## HEATING/VENTILATION/AIR CONDITIONING 11-31

ITEM	PART NUMBER	DESCRIPTION	QTY
		<b>Figure 11-15.</b> <b>Auxiliary A/C-Heat Hoses.</b>	
1	6006175	O-RING, #10, A/C . . . . .	1
2	N/S	CLAMP, hose . . . . .	2
3	5744152	HOSE, heater, 5/8" SEE NOTE 1 . . . . .	1
4	6009772	HOSE, #10, suction, low pressure . . . . .	1
5	5743187	SCREW, tapping, flanged, #10 - 16 x 3/4 . . . . .	3
6	5743166	GROMMET, 3" . . . . .	1
7	6009301	HOSE, #6 liquid, high pressure . . . . .	1
8	6006173	O-RING, #6, A/C . . . . .	1
9	N/S	SCREW, tapping, phcr, #8 - 20 x 1/2 . . . . .	4
10	N/S	BOLT, 1/4 - 20 x 1/2, Gr5, ZN . . . . .	1
11	N/S	P-CLAMP, 2 1/2", SEE NOTE 2 . . . . .	2
12	N/S	LOCKNUT, Keps, 1/4 - 20, ZN . . . . .	1
	5743167	TAPE, permagum/prestite, 12" (not illustrated) . . . . .	AR
		NOTE 1: HEATER HOSE, P/N 5744152, COMES IN A 8' 4" LENGTH THAT IS TO BE CUT TO MAKE TWO 4' 2" HOSES FOR BOTH THE INLET AND OUTLET OF THE AUXILIARY A/C-HEAT UNIT OR CAN BE MADE FROM BULK HOSE 50', P/N 5740929.	
		NOTE 2: THIS CLAMP SECURES THE HEATER AND A/C HOSES, AFTER THEY PASS THROUGH THE GROMMET, TO THE INBOARD SIDE OF THE R.H. FRAME RAIL.	

# 2001 HUMMER PARTS CATALOG

## 11-32 HEATING/VENTILATION/AIR CONDITIONING

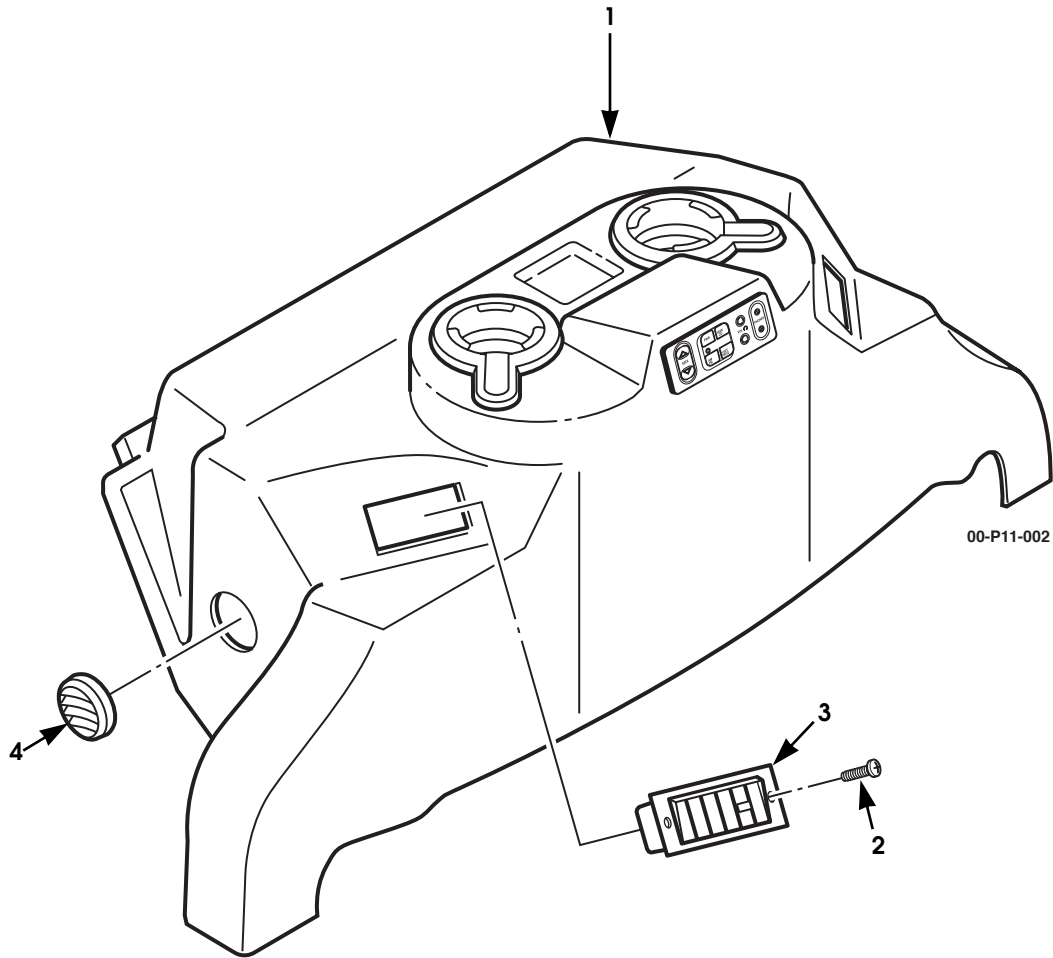

Figure 11-16. Rear Center Console.

# 2001 HUMMER PARTS CATALOG

## HEATING/VENTILATION/AIR CONDITIONING 11-33

ITEM	PART NUMBER	DESCRIPTION	QTY
		<b>Figure 11-16. Rear Center Console.</b>	
1	6010973	CONSOLE ASSEMBLY, rear, standard, tan. . . . .	1
1	6010973G	CONSOLE ASSEMBLY, rear, standard, gray. . . . .	1
1	6011049	CONSOLE ASSEMBLY, rear, with rear seat audio, tan . .	1
1	6011049G	CONSOLE ASSEMBLY, rear, with rear seat audio, gray .	1
2	N/S	SCREW, #6-32 x 3/4 . . . . .	4
3	5744793	LOUVER, rectangular, w/o adapter, SEE NOTE 1 . . . . .	2
4	5743504	LOUVER, circular, side vent . . . . .	3
		 NOTE 1: PART OF DASH KIT, P/N 6009548	

# 2001 HUMMER PARTS CATALOG

## 11-34 HEATING/VENTILATION/AIR CONDITIONING

# 2001 HUMMER PARTS CATALOG

ELECTRICAL 12-1

## Section 12

### ELECTRICAL

TITLE	PAGE NUMBER
124-AMP Alternator Assembly . . . . .	12-12
Batteries, Cables, And Mounting Hardware . . . . .	12-4
Clearance Marker Light Assembly. . . . .	12-34
Console Harness Assembly . . . . .	12-100
Cowl Top Harness . . . . .	12-131
Cross Body Harness. . . . .	12-126
CTIS Interior Harness Assembly. . . . .	12-110
Daytime Running Light Jumper and Harness . . . . .	12-72
Delco Monsoon Stereo System Harness, Hard Top, Models 83 & 84. . . . .	12-64
Delco Standard Stereo Harness Two-Speaker, Two-Door, Model 89 . . . . .	12-60
Delco Standard Stereo Harness, Four-Speaker, Open Top, Model 90 . . . . .	12-66
Delco Standard Stereo Harness, Four-Speaker, Hard Top, Models 83 & 84 . . . . .	12-62
Door Harness Assembly, Front . . . . .	12-84
Dual Horns . . . . .	12-48
Engine Harness Assembly, AM General . . . . .	12-98
Engine Harness Assembly, GM . . . . .	12-142
Exterior Fuse Box Power Cable . . . . .	12-118
Front Turn Signal Light and Mounting Hardware . . . . .	12-28
Fuse Boxes, Internal & External . . . . .	12-92
Glow Plug Power Cable Assembly . . . . .	12-114
Harness Assembly, Monsoon, Soft-Top. . . . .	12-68
Harness Assembly, Slant-Back Cargo Door, Model 91 . . . . .	12-134
Harness Assembly, Slant-Back Rear Defrost, Model 91 . . . . .	12-136
Harness Assembly, Station Wagon Rear Door Jumper (RH Side) . . . . .	12-140
Headlight Assembly and Running Lights . . . . .	12-32
Heated Power Exterior Mirrors . . . . .	12-86
Hood Wiring Harness. . . . .	12-51
Identification Lamp Assembly Jumper. . . . .	12-58
Instrument Panel Cluster . . . . .	12-23
Instrument Panel Harness. . . . .	12-122
Interior Courtesy Lights, Underhood Light, and Door Jamb Switch. . . . .	12-40
Interior Dome Lights . . . . .	12-36
Interior Ground Cable Assembly. . . . .	12-116
Miscellaneous Electrical Items. . . . .	12-146
Monsoon System, Soft-Top . . . . .	12-70
PCM and Digital Ratio Adapter . . . . .	12-144
Power Door Locks . . . . .	12-76
Power Mirror Jumper Harness Assembly . . . . .	12-88
Power Mirror Jumper Harness Assembly, Heated. . . . .	12-90
Power Mirror Switch Harness Assembly . . . . .	12-120
Power Window. . . . .	12-95

# 2001 HUMMER PARTS CATALOG

## 12-2 ELECTRICAL

TITLE	PAGE NUMBER
Rear Seat Audio . . . . .	12-74
Rear Turn Signal Light/Taillight, License Plate Bracket, and Mounting Hardware . . . . .	12-30
Reflectors . . . . .	12-42
Remote Entry Transmitter and Receiver . . . . .	12-148
Right Front Wheel Sensor Jumper Harness Assembly . . . . .	12-112
Roof Wiring Harness Assembly, Four-Door, Model 83 . . . . .	12-106
Roof Wiring Harness Assembly, Station Wagon, Model 84. . . . .	12-108
Roof Wiring Harness Assembly, Two-Door, Model 89 . . . . .	12-104
Roof Wiring Harness, Open Top . . . . .	12-54
Sensors, Sending Units, and Switches . . . . .	12-14
Slant-Back Harness, Model 91 . . . . .	12-138
Starter Motor And Mounting Hardware . . . . .	12-6
Starter Motor Assembly . . . . .	12-8
Stereo, Speakers, and Mounting Hardware, Standard and Monsoon (Delco) . . . . .	12-44
Trailer Towing Wiring . . . . .	12-56
Transmission Harness Assembly . . . . .	12-102
Underbody Harness, Rear. . . . .	12-124
Windshield Wiper Motor, Wiper Assembly, and Washer Bottle . . . . .	12-16
Wiper Motor And Blade, Slant-Back Rear Window . . . . .	12-20





# 2001 HUMMER PARTS CATALOG

## 12-4 ELECTRICAL

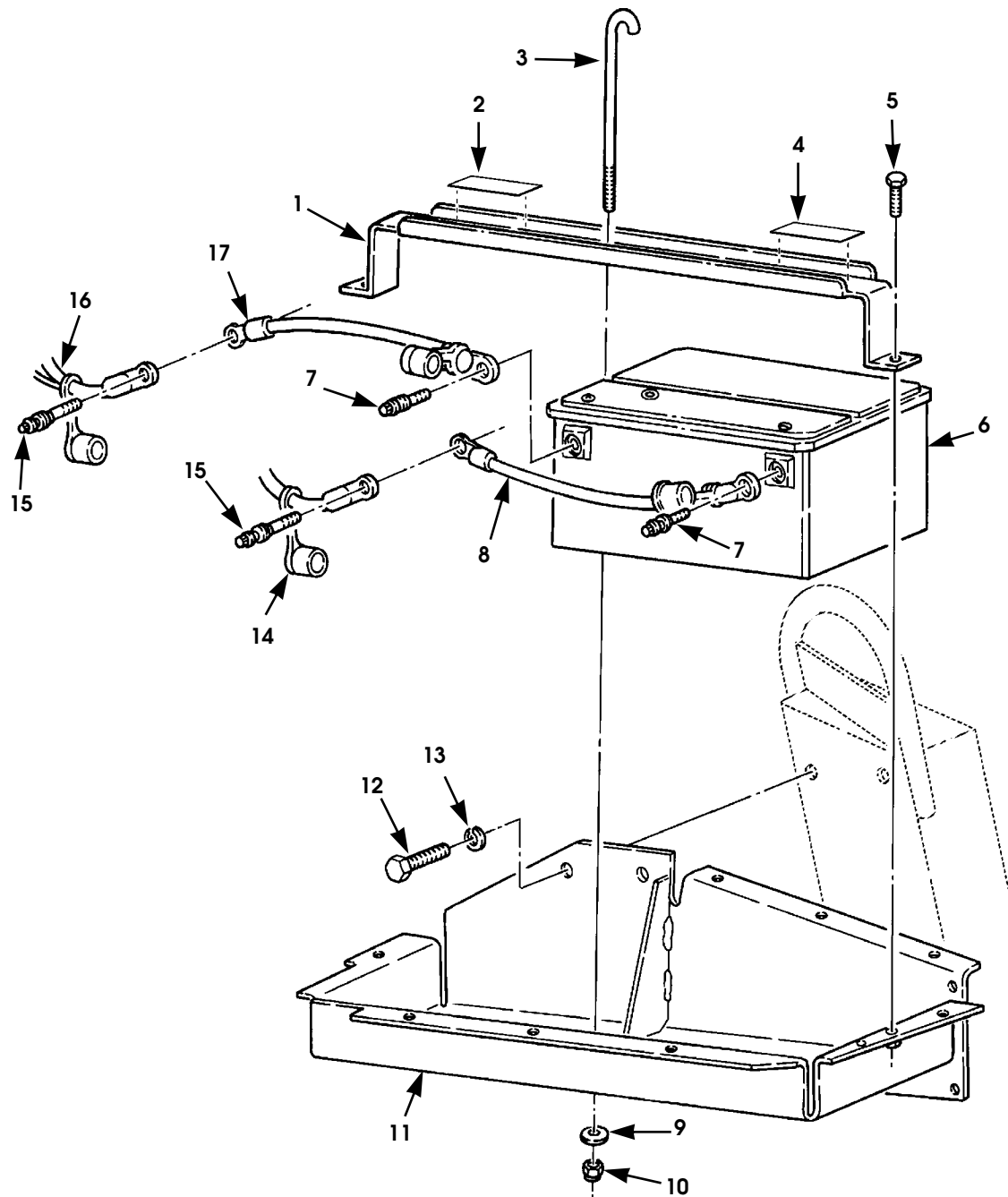

P12-001

Figure 12-1. Batteries, Cables, And Mounting Hardware.

# 2001 HUMMER PARTS CATALOG

## ELECTRICAL 12-5

ITEM	PART NUMBER	DESCRIPTION	QTY
		<b>Figure 12-1. Batteries, Cables, And Mounting Hardware.</b>	
1	6002911B9	BRACKET, battery holddown . . . . .	1
2	6006813	LABEL, accessory drive belt routing, English . . . . .	1
3	6002912	J-BOLT, 5/16 - 18 x 8, ZN, battery holddown . . . . .	1
4	6003864	LABEL, battery warning, English . . . . .	1
4	6004096	LABEL, battery warning, French . . . . .	1
4	6004178	LABEL, battery warning, Spanish . . . . .	1
4	6004179	LABEL, battery warning, Arabic . . . . .	1
5	N/S	BOLT, 5/16 - 18 x 3/4, Gr8, ZN, battery holddown . . . . .	2
6	6009922	BATTERY, 12-volt . . . . .	2
7	6003471	BOLT, battery, side terminal, 5/8" long . . . . .	2
8	6003128	CABLE, black, negative . . . . .	1
9	12340058	WASHER, hardened . . . . .	1
10	N/S	NUT, 5/16 - 18, Gr8, CAD . . . . .	1
11	6002907B9	BATTERY TRAY . . . . .	1
12	N/S	BOLT, 3/8 - 16 x 1, Gr8, CAD . . . . .	2
13	N/S	LOCKWASHER, med, 3/8, ZN . . . . .	2
14	6009471	CABLE, starter, negative . . . . .	1
15	5744361	BOLT, battery, side terminal, 1" long . . . . .	2
16	6009470	CABLE, starter, positive . . . . .	1
17	6003129	CABLE, red, positive . . . . .	1

# 2001 HUMMER PARTS CATALOG

## 12-6 ELECTRICAL

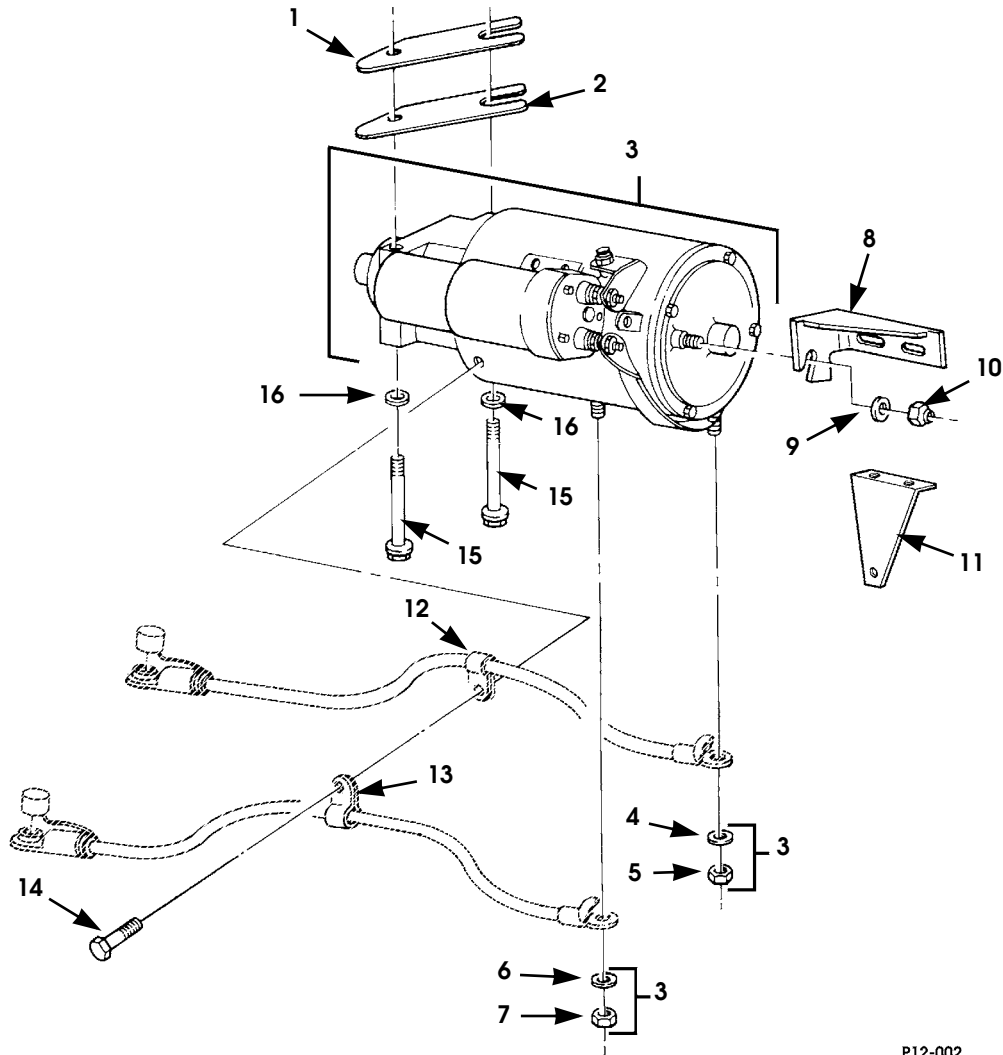

P12-002

Figure 12-2. Starter Motor And Mounting Hardware.

# 2001 HUMMER PARTS CATALOG

## ELECTRICAL 12-7

ITEM	PART NUMBER	DESCRIPTION	QTY
		<b>Figure 12-2. Starter Motor And Mounting Hardware.</b>	
1	12338789-2	SHIM .....	V
2	12338789-1	SHIM .....	V
3	5937124	STARTER MOTOR ASSEMBLY .....	1
3	5744719	STARTER MOTOR ASSEMBLY, remanufactured.....	1
4	S.I.A.	•LOCKWASHER, 1/2 med, ZN.....	1
5	S.I.A.	•NUT, 1/2 Gr 5, CAD .....	1
6	S.I.A.	•LOCKWASHER, 3/8 med, ZN.....	1
7	S.I.A.	•NUT, 3/8-16 Gr 5 CAD .....	1
8	ECEX4939	BRACKET, starter motor .....	1
9	N/S	WASHER, bracket 3/8 Hard Type B, Flat ZN .....	1
10	N/S	LOCKNUT, bracket 3/8-16-GR 8 .....	1
11	6003475	BRACKET, starter cable .....	1
12	N/S	CLAMP, positive cable 3/4 cushioned.....	1
13	N/S	CLAMP, ground cable 7/8 cushioned .....	1
14	12340844	SCREW, cable clamps .....	1
15	12339413	BOLT, starter .....	2
16	12341856	WASHER, starter .....	2

# 2001 HUMMER PARTS CATALOG

## 12-8 ELECTRICAL

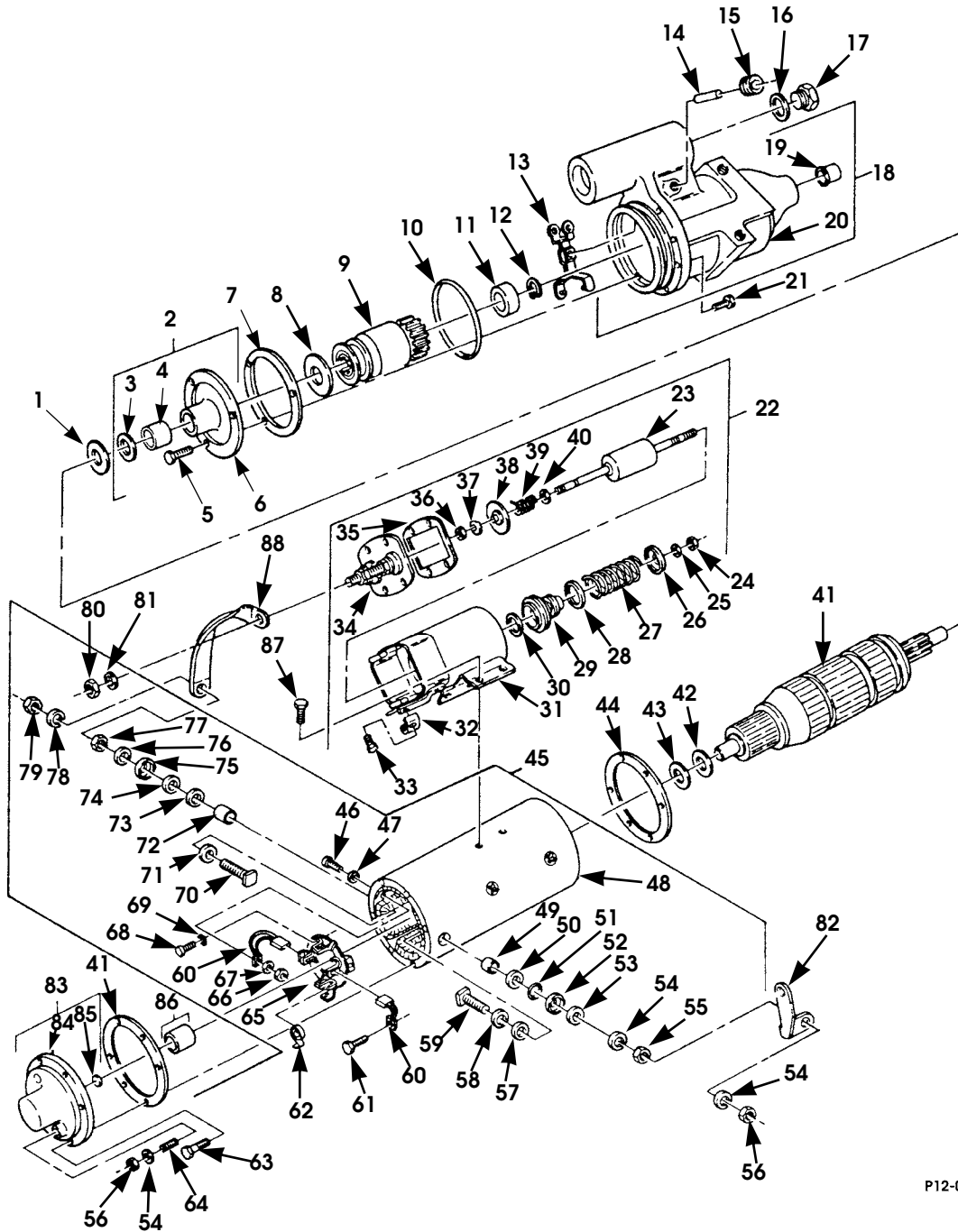

P12-003

Figure 12-3. Starter Motor Assembly.

# 2001 HUMMER PARTS CATALOG

## ELECTRICAL 12-9

ITEM	PART NUMBER	DESCRIPTION	QTY
		<b>Figure 12-3. Starter Motor Assembly.</b>	
1	S.I.K.	WASHER, flat, SEE NOTE 1 . . . . .	1
2	5741114	BEARING ASSEMBLY, intermediate . . . . .	1
3	5929739	•SEAL . . . . .	1
4	5929738	•BEARING, ABS, bronze . . . . .	1
5	S.I.A.	•SCREW, SEE NOTE 2 . . . . .	3
6	S.I.A.	•HOUSING, intermediate bearing assembly . . . . .	1
7	S.I.K.	GASKET, SEE NOTE 3 . . . . .	1
8	S.I.K.	SPACER, starter clutch, SEE NOTE 1 . . . . .	1
9	5740926	CLUTCH, starter . . . . .	1
10	5929752	O-RING, pinion housing . . . . .	1
11	S.I.K.	PINION STOP, SEE NOTE 4 . . . . .	1
12	S.I.K.	SNAP RING, SEE NOTE 4 . . . . .	1
13	5929764	YOKE ASSEMBLY . . . . .	1
14	S.I.K.	PIN, SEE NOTE 5 . . . . .	2
15	S.I.K.	PLUG, SEE NOTE 5 . . . . .	1
16	S.I.K.	GASKET, SEE NOTE 5 . . . . .	1
17	S.I.K.	PLUG, SEE NOTE 5 . . . . .	1
18	5742921	HOUSING ASSEMBLY, pinion . . . . .	1
19	5741174	•BEARING, bronze . . . . .	1
20	S.I.A.	•HOUSING . . . . .	1
21	S.I.K.	SCREW, SEE NOTE 6 . . . . .	7
22	5742738	SOLENOID SWITCH ASSEMBLY . . . . .	1
23	5742922	•CORE ASSEMBLY, moving . . . . .	1
24	S.I.A.	•NUT, SEE NOTE 5 . . . . .	1
25	S.I.A.	•SNAP RING, SEE NOTE 7 . . . . .	1
26	S.I.A.	•RETAINER, SEE NOTE 7 . . . . .	1
27	S.I.A.	•SPRING, SEE NOTE 7 . . . . .	1
28	S.I.A.	•RETAINER, SEE NOTE 7 . . . . .	1
29	5929759	•BOOT, moving core, SEE NOTE 7 . . . . .	1
30	S.I.A.	•WASHER, SEE NOTE 7 . . . . .	1
31	S.I.A.	•HOUSING, solenoid . . . . .	1
32	5741916	•LOCKWASHER, solenoid . . . . .	1
33	N/S	•MACHINE SCREW . . . . .	1
34	5740968	•COVER AND CONTACT STUD ASSEMBLY . . . . .	1
35	S.I.A.	•GASKET, SEE NOTE 8 . . . . .	1
36	S.I.A.	•NUT, SEE NOTE 9 . . . . .	1
37	S.I.A.	•WASHER, SEE NOTE 9 . . . . .	1
38	S.I.A.	•CONTACT, SEE NOTE 9 . . . . .	1
39	S.I.A.	•SPRING, SEE NOTE 9 . . . . .	1

# 2001 HUMMER PARTS CATALOG

## 12-10 ELECTRICAL

ITEM	PART NUMBER	DESCRIPTION	QTY
		<b>Figure 12-3. Starter Motor Assembly. (Cont'd)</b>	
40	S.I.A.	•WASHER, SEE NOTE 9 . . . . .	1
41	5742918	ARMATURE ASSEMBLY . . . . .	1
42	S.I.K.	THRUST WASHER, SEE NOTE 1 . . . . .	1
43	S.I.K.	THRUST WASHER, SEE NOTE 1 . . . . .	8
44	S.I.K.	GASKET, SEE NOTE 10 . . . . .	2
45	5742920	FRAME AND FIELD ASSEMBLY . . . . .	1
46	N/S	•SCREW . . . . .	2
47	5741118	•WASHER . . . . .	2
48	S.I.A.	•HOUSING, frame and field assembly . . . . .	1
49	S.I.A.	•BUSHING, SEE NOTE 11 . . . . .	1
50	S.I.A.	•WASHER, neoprene, SEE NOTE 11 . . . . .	1
51	S.I.A.	•WASHER, insulating, SEE NOTE 11 . . . . .	1
52	S.I.A.	•WASHER, cap, SEE NOTE 11 . . . . .	1
53	S.I.A.	•WASHER, plain, SEE NOTE 11 . . . . .	1
54	S.I.A.	•LOCKWASHER, SEE NOTE 11 . . . . .	4
55	S.I.A.	•NUT, SEE NOTE 11 . . . . .	1
56	S.I.A.	•NUT, SEE NOTE 11 . . . . .	4
57	S.I.A.	•WASHER, insulating, SEE NOTE 11 . . . . .	1
58	S.I.A.	•WASHER, plain, SEE NOTE 11 . . . . .	1
59	S.I.A.	•STUD, terminal, SEE NOTE 11 . . . . .	1
60	5740960	•BRUSH SET . . . . .	1
61	N/S	•SCREW . . . . .	2
62	5740961	•SPRING SET, brush . . . . .	1
63	S.I.A.	•SCREW, SEE NOTE 6 . . . . .	4
64	S.I.A.	•STUD, terminal, SEE NOTE 11 . . . . .	1
65	5741666	•PLATE ASSEMBLY, brush . . . . .	1
66	N/S	•NUT . . . . .	2
67	5741107	•LOCKWASHER . . . . .	2
68	N/S	•SCREW . . . . .	3
69	5741169	•SEAL PACKAGE, brush plate mounting . . . . .	1
70	S.I.A.	•STUD, terminal, SEE NOTE 11 . . . . .	1
71	S.I.A.	•WASHER, insulating, SEE NOTE 11 . . . . .	1
72	S.I.A.	•BUSHING, insulating, SEE NOTE 11 . . . . .	1
73	S.I.A.	•WASHER, neoprene, SEE NOTE 11 . . . . .	1
74	S.I.A.	•WASHER, insulating, SEE NOTE 11 . . . . .	1
75	S.I.A.	•WASHER, cap, SEE NOTE 11 . . . . .	1
76	S.I.A.	•WASHER, plain, SEE NOTE 11 . . . . .	1
77	S.I.A.	•NUT, SEE NOTE 11 . . . . .	1
78	S.I.A.	•LOCKWASHER, SEE NOTE 11 . . . . .	2

# 2001 HUMMER PARTS CATALOG

## ELECTRICAL 12-11

ITEM	PART NUMBER	DESCRIPTION	QTY
		<b>Figure 12-3. Starter Motor Assembly. (Cont'd)</b>	
79	S.I.A.	•NUT, SEE NOTE 11 .....	3
80	N/S	•NUT .....	2
81	N/S	•WASHER .....	2
82	5741120	CONNECTOR switch .....	1
83	5742919	HEAD ASSEMBLY, commutator end .....	1
84	S.I.A.	•HEAD, commutator end .....	1
85	S.I.A.	•OIL RETAINER, felt, SEE NOTE 2 .....	1
86	S.I.A.	•BEARING, bronze , SEE NOTE 2 .....	1
87	5741117	CONNECTOR, switch .....	1
88	S.I.K.	SCREW, solenoid , SEE NOTE 6 .....	4
		NOTE 1: PART OF BEARING AND RETAINER KIT (THRUST WASHER PACKAGE), P/N 5741171	
		NOTE 2: PART OF BEARING AND OIL RETAINER KIT, P/N 5741167	
		NOTE 3: PART OF GASKET KIT, INTERMEDIATE BEARING P/N 5740964	
		NOTE 4: PART OF PINION STOP AND LOCK RING KIT, P/N 5741173	
		NOTE 5: PART OF YOKE ADJUSTING PARTS KIT P/N 5929744	
		NOTE 6: PART OF MOUNTING SCREW KIT, P/N 5740922	
		NOTE 7: PART OF STARTER RELAY KIT (CORE YOKE END PARTS PACKAGE), P/N 5929758	
		NOTE 8: PART OF GASKET SWITCH KIT, P/N 5929755	
		NOTE 9: PART OF CORE CONTACT KIT, P/N 5929757	
		NOTE 10: PART OF GASKET KIT (GASKET PACKAGE, C.E. AND D.E. HEAD), P/N 5741168	
		NOTE 11: PART OF TERMINAL STUD KIT, P/N 5740963	



# 2001 HUMMER PARTS CATALOG

## 12-12 ELECTRICAL

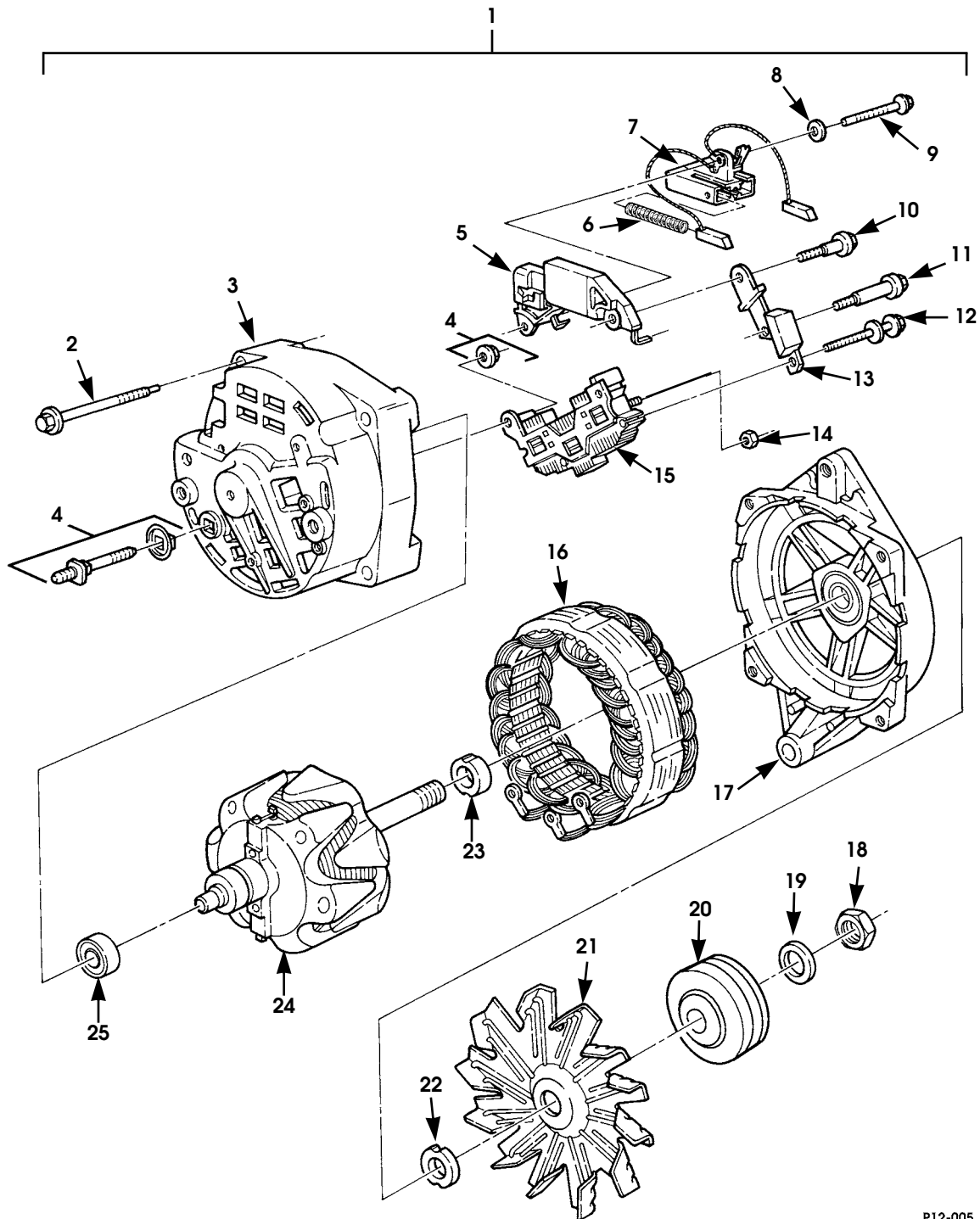

P12-005

Figure 12-4. 124-AMP Alternator Assembly.

# 2001 HUMMER PARTS CATALOG

## ELECTRICAL 12-13

ITEM	PART NUMBER	DESCRIPTION	QTY
		<b>Figure 12-4. 124-AMP Alternator Assembly.</b>	
1	6006776	ALTERNATOR ASSEMBLY, 124-Amp . . . . .	1
1	5744687	ALTERNATOR ASSEMBLY, 124-Amp, remanufactured . .	1
2	5742662	•BOLT, frame . . . . .	4
3	5742663	•FRAME, 124-amp alternator, includes bearings . . . .	1
4	8125185	•TERMINAL PACKAGE, battery . . . . .	1
5	5742664	•REGULATOR . . . . .	1
6	5742665	•SPRING, brush . . . . .	2
7	5742666	•BRUSH HOLDER AND BRUSH ASSEMBLY . . . . .	1
8	NPN	•WASHER . . . . .	1
9	5733274	•SCREW, brush holder . . . . .	1
10	5742667	•SCREW, regulator . . . . .	1
11	5742668	•SCREW, rectifier bridge . . . . .	1
12	5742669	•SCREW AND WASHER, rectifier bridge . . . . .	2
13	5742670	•CAPACITOR . . . . .	1
14	453996	•NUT, rectifier bridge . . . . .	3
15	5742672	•RECTIFIER BRIDGE . . . . .	1
16	5742673	•STATOR ASSEMBLY . . . . .	1
17	5742674	•FRAME, D.E., includes bearings . . . . .	1
18	8125242	•NUT, pulley . . . . .	1
19	8125186	•LOCKWASHER, shaft nut, D.E. . . . .	1
20	S.I.A.	•PULLEY, alternator . . . . .	1
21	8125193	•FAN . . . . .	1
22	5742676	•COLLAR, outside . . . . .	1
23	5742677	•COLLAR, inside . . . . .	1
24	5742678	•ROTOR ASSEMBLY . . . . .	1
25	5742679	•BALL BEARING, S.R.E. . . . .	1

# 2001 HUMMER PARTS CATALOG

## 12-14 ELECTRICAL

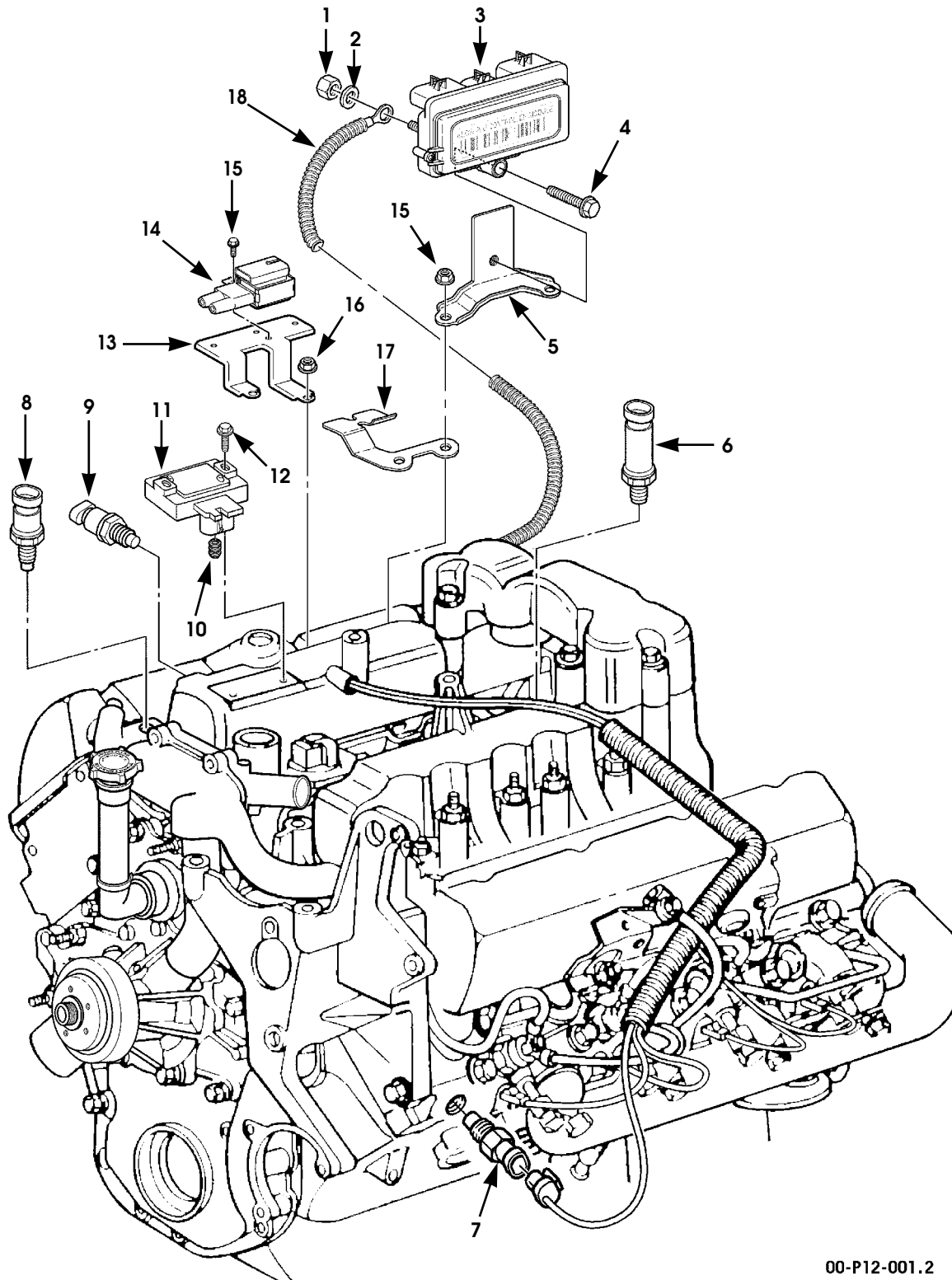

00-P12-001.2

Figure 12-5. Sensors, Sending Units, and Switches.

# 2001 HUMMER PARTS CATALOG

## ELECTRICAL 12-15

ITEM	PART NUMBER	DESCRIPTION	QTY
		<b>Figure 12-5. Sensors, Sending Units, and Switches.</b>	
1	N/S	NUT, flanged, 5/16-18. . . . .	1
2	N/S	WASHER, flat, M10 . . . . .	1
3	5745246	GLOWPLUG CONTROLLER . . . . .	1
4	N/S	BOLT, flanged, 5/16-18 x 1 1/4. . . . .	1
5	N/S	BRACKET, glowplug controller . . . . .	1
6	5745120	SENDER SWITCH, oil pressure. . . . .	1
7	5744032	SENDER, temperature gauge. . . . .	1
8	5744030	SENSOR, coolant temperature. . . . .	1
9	5744430	SENSOR, air intake temperature . . . . .	1
10	5744468	SEAL, pressure sensor. . . . .	1
11	5745121	SENSOR, turbo pressure. . . . .	1
12	5744467	BOLT, pressure sensor. . . . .	2
13	5744442	BRACKET, solenoid valve mounting . . . . .	1
14	5745247	SOLENOID VALVE, boost control . . . . .	1
15	5744472	BOLT, solenoid valve . . . . .	1
16	N/S	NUT, hex flange, M10 - 1.5. . . . .	4
17	N/S	BRACKET . . . . .	1
18	6010339	CABLE, glow plug controller-to-starter . . . . .	1

# 2001 HUMMER PARTS CATALOG

## 12-16 ELECTRICAL

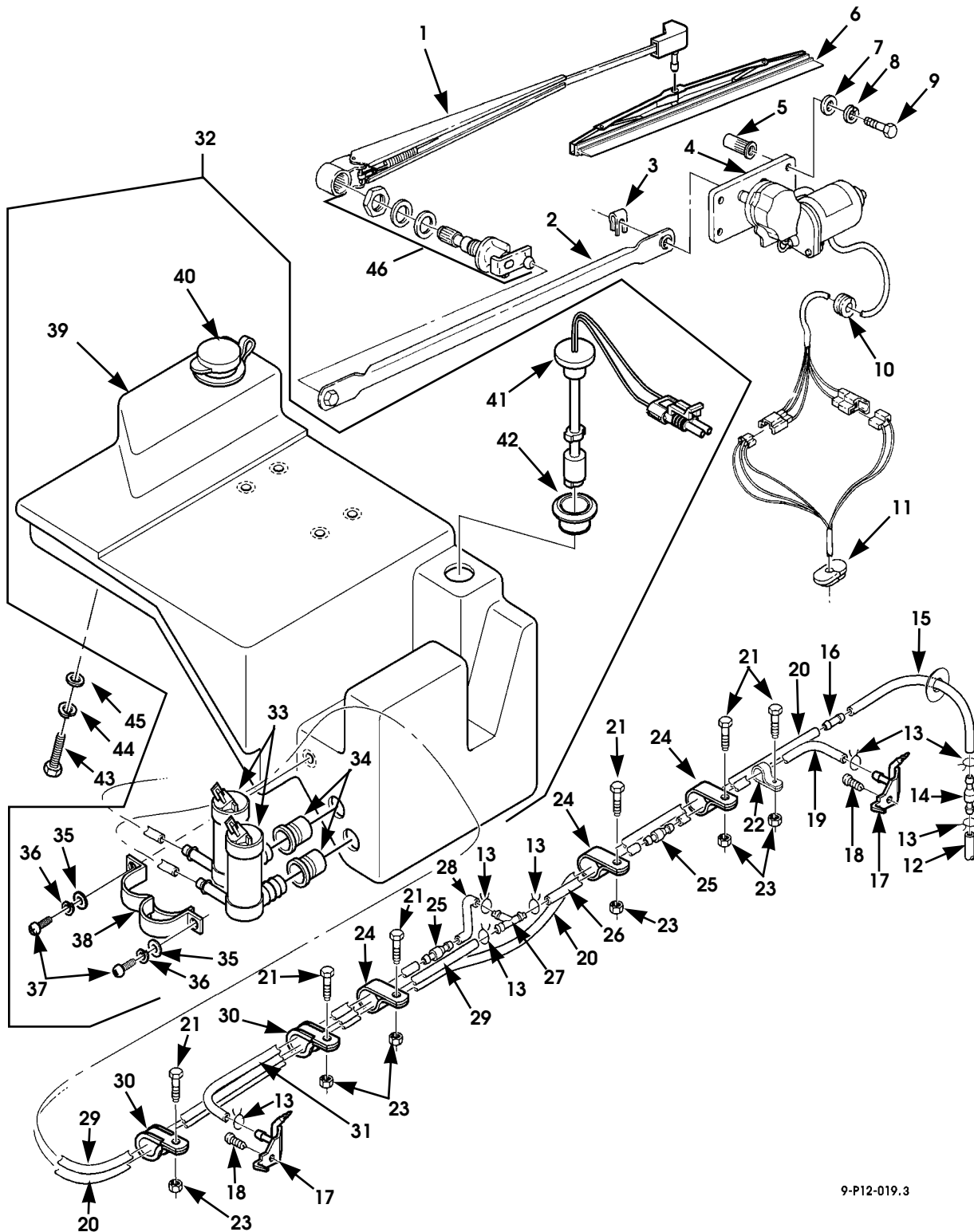

9-P12-019.3

Figure 12-6. Windshield Wiper Motor, Wiper Assembly, and Washer Bottle.

# 2001 HUMMER PARTS CATALOG

## ELECTRICAL 12-17

ITEM	PART NUMBER	DESCRIPTION	QTY
		<b>Figure 12-6. Windshield Wiper Motor, Wiper Assembly, and Washer Bottle.</b>	
1	6003900	WIPER ARM ASSEMBLY, pivot assembly, less blade . . .	2
2	12338831	CONNECTING ARM, pivot assembly . . . . .	2
3	12339427	RETAINER. . . . .	1
4	5938822B2	WIPER MOTOR ASSEMBLY, windshield . . . . .	1
5	N/S	NUT INSERT, 1/4 - 20, 3/8" O.D. x 1" long . . . . .	3
6	6003901	BLADE, wiper arm assembly . . . . .	2
7	N/S	WASHER, flat, 1/4, CAD, wiper motor . . . . .	3
8	N/S	LOCKWASHER, med, 1/4, ZN, wiper motor. . . . .	3
9	N/S	SCREW, 1/4 - 20 x 3/4, Gr5, CAD, wiper motor. . . . .	3
10	MS35489-41S	GROMMET, w/s wiper motor lead . . . . .	1
11	12339340	GROMMET, w/s wiper motor harness . . . . .	1
12	N/S	HOSE, check valve-to-rear window washer, 254" SEE NOTE 1 91	1
13	WWC440-3/8	CLAMP, w/s washer hose . . . . .	7
14	6010771	CHECK VALVE, rear window washer hose, SEE NOTE 2 91	1
15	6011554	HOSE, connector-to-check valve . . . . .	1
16	6011552	CONNECTOR, hose . . . . .	1
17	6006600	NOZZLE, windshield washer . . . . .	2
18	N/S	SCREW, phcr, tapping, #8 - 32 x 5/8, CAD, nozzle . . . . .	2
19	N/S	HOSE, RH, 13-inch, check valve-to-nozzle, SEE NOTE 3.	1
20	6011553	HOSE, pump to connector. . . . .	1
21	N/S	SCREW, slotted hex head, #10 - 24 x 3/4, CAD . . . . .	6
22	N/S	P-CLIP, 3/8", windshield washer hose . . . . .	1
23	N/S	LOCKNUT, #10 - 24, CAD, w/s washer hose P-clip . . . . .	4
24	N/S	P-CLIP, 7/8", windshield washer hose . . . . .	3
25	6005960	CHECK VALVE, windshield washer hose, SEE NOTE 2 . . . . .	2
26	N/S	HOSE, RH, 13-inch, tee-to-check valve, SEE NOTE 3 . . . . .	1
27	6010625	TEE, windshield washer hose . . . . .	1
28	N/S	HOSE, LH, 3-inch, tee-to-check valve, SEE NOTE 3 . . . . .	1
29	6010626	HOSE, w/s washer pump-to-tee. . . . .	1
30	N/S	P-CLIP, 5/8", cushioned, windshield washer hose . . . . .	2
31	N/S	HOSE, LH, 13-inch, check valve-to-nozzle, SEE NOTE 3.	1
32	6010005	RESERVOIR AND PUMP ASSEMBLY, windshield washer . 83, 84, 89, 90	1
32	6010935	RESERVOIR AND PUMP ASSEMBLY, windshield washer . 91	3
33	6010252	•PUMP, windshield washer . . . . . 83, 84, 89, 90	1
33	6010252	•PUMP, windshield and slant-back door window washer 91	2

# 2001 HUMMER PARTS CATALOG

## 12-18 ELECTRICAL

ITEM	PART NUMBER	DESCRIPTION	QTY
		<b>Figure 12-6. Windshield Wiper Motor, Wiper Assembly, and Washer Bottle.</b>	
34	S.I.A.	•SEAL, windshield washer pump . . . . . 83, 84, 89, 90	1
34	S.I.A.	•SEAL, windshield and slant-back door window washer pump . . . . . 91	2
35	S.I.A.	•WASHER, flat, #10 . . . . .	2
36	S.I.A.	•LOCKWASHER, #10. . . . .	2
37	S.I.A.	•SCREW, phcr #10 - 24 x 1/2 . . . . .	2
38	6010970	•RETAINER, windshield washer pump . . . . .	1
39	6010284	•RESERVOIR, windshield washer . . . . .	1
40	S.I.A.	•CAP, windshield washer reservoir . . . . .	1
41	S.I.A.	•SEAL, windshield washer low level switch . . . . .	1
42	6010250	•SWITCH ASSEMBLY, low level w/s washer fluid . . . . .	1
43	N/S	SCREW, 1/4-20 x 3/4 . . . . .	4
44	N/S	LOCKWASHER, 1/4 . . . . .	4
45	N/S	WASHER, flat, 1/4 . . . . .	4
46	12340660	PIVOT ASSEMBLY, windshield wiper motor . . . . .	2
		NOTE 1: CUT TO LENGTH FROM 50' ROLL BULK HOSE, P/N 5741211.	
		NOTE 2: CHECK VALVES P/NS 6005960 AND 6010771 ARE INTERCHANGEABLE AS REPLACEMENT PARTS.	
		NOTE 3: MAKE FROM BULK HOSE P/N 5741211	

# 2001 HUMMER PARTS CATALOG

ELECTRICAL 12-19



# 2001 HUMMER PARTS CATALOG

## 12-20 ELECTRICAL

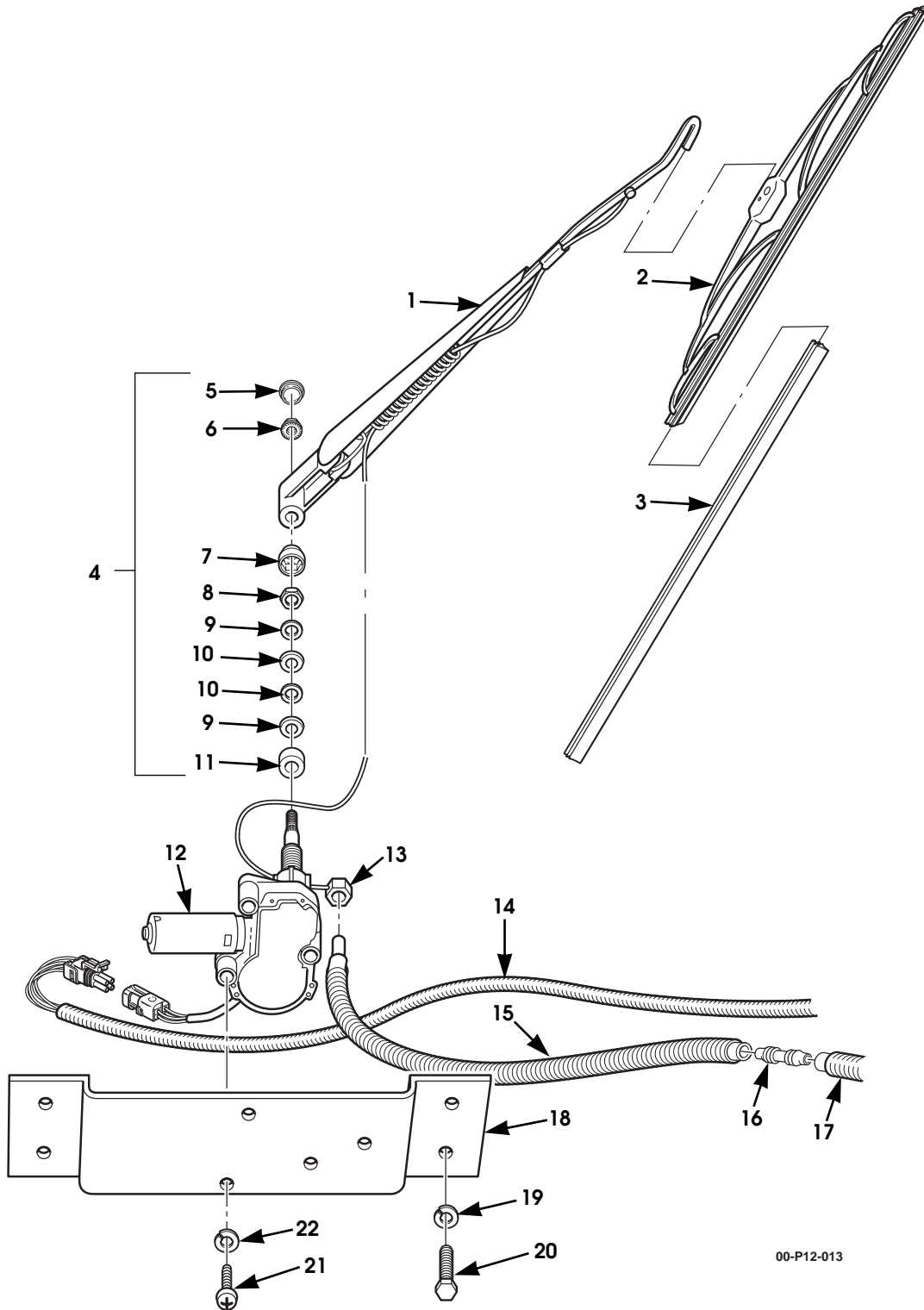

00-P12-013

Figure 12-7. Wiper Motor And Blade, Slant-Back Rear Window.

# 2001 HUMMER PARTS CATALOG

## ELECTRICAL 12-21

ITEM	PART NUMBER	DESCRIPTION	QTY
		<b>Figure 12-7.</b> <b>Wiper Motor And Blade, Slant-Back Rear Window.</b>	
1	6010967	WIPER ARM . . . . .	1
2	6010968	WIPER BLADE . . . . .	1
3	N/S	BLADE REFILL . . . . .	1
4	6010969	WIPER HARDWARE KIT . . . . .	1
5	S.I.K.	•PLASTIC CAP . . . . .	1
6	S.I.K.	•NUT, 8mm . . . . .	1
7	S.I.K.	•WEATHER CAP . . . . .	1
8	S.I.K.	•NUT . . . . .	1
9	S.I.K.	•WASHER COVER . . . . .	2
10	S.I.K.	•RUBBER WASHER . . . . .	2
11	S.I.K.	•SPACER . . . . .	1
12	6010966	WIPER MOTOR ASSEMBLY . . . . .	1
13	6010817	ADAPTER ASSEMBLY, wet arm . . . . .	1
14	6011057	HARNESS, slant-back door . . . . .	1
15	N/S	HOSE, window washer, 254" SEE NOTE 1 . . . . .	1
16	6011552	CONNECTOR, hose . . . . .	1
17	6011554	HOSE, washer. . . . .	1
18	6010887	WIPER MOTOR MOUNTING BRACKET . . . . .	1
19	9424257	LOCKWASHER . . . . .	4
20	N/S	BOLT, 1/4 - 20 x 1 . . . . .	4
21	N/S	SCREW, M6-1.00 x 15 . . . . .	3
22	11503962	LOCKWASHER . . . . .	3
		NOTE 1: CUT TO LENGTH FROM 50' ROLL BULK HOSE, P/N 5741211.	



# 2001 HUMMER PARTS CATALOG

ELECTRICAL 12-23

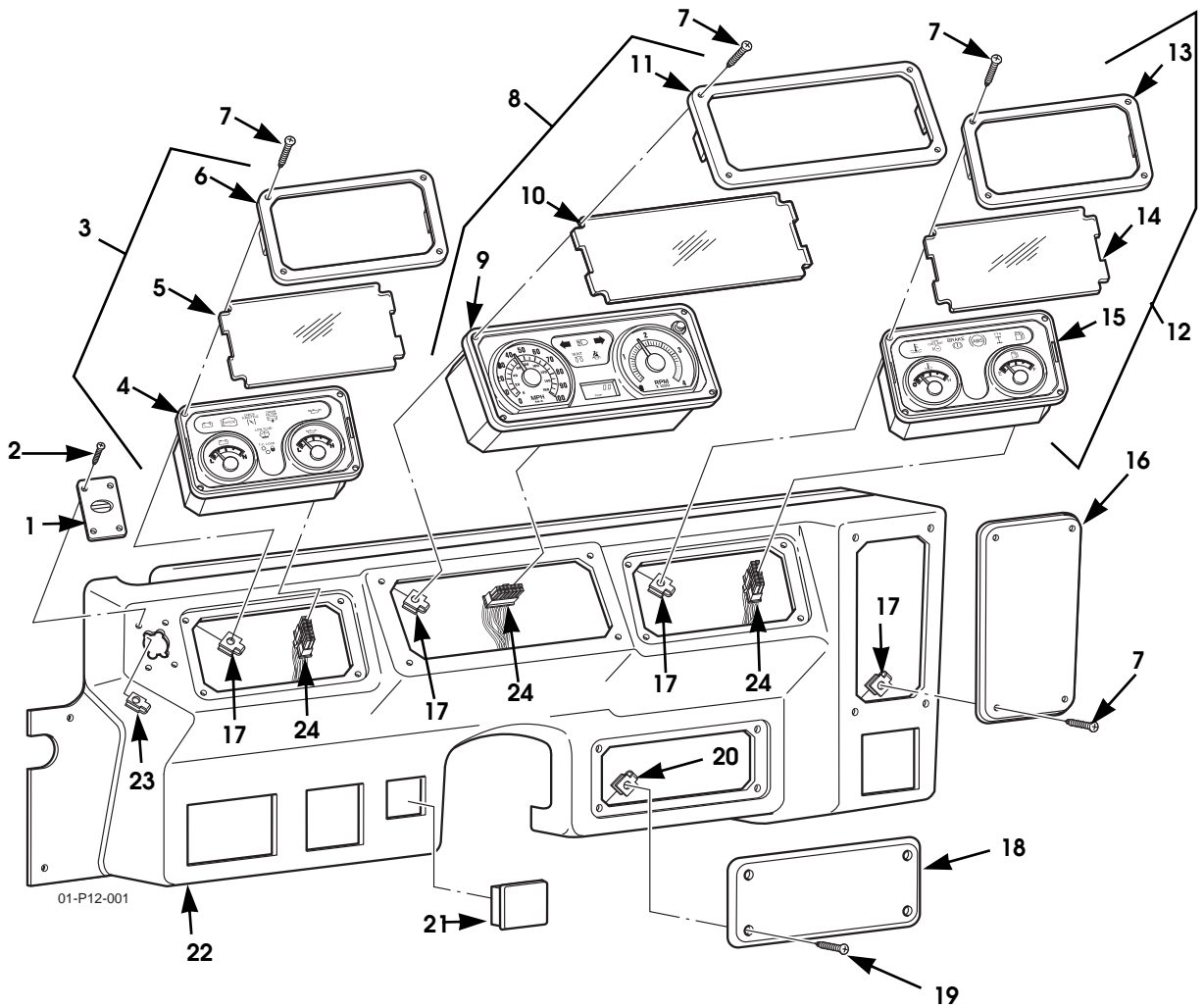

Figure 12-8. Instrument Panel Cluster  
(Sheet 1 of 2).

AM General Corporation

# 2001 HUMMER PARTS CATALOG

## 12-24 ELECTRICAL

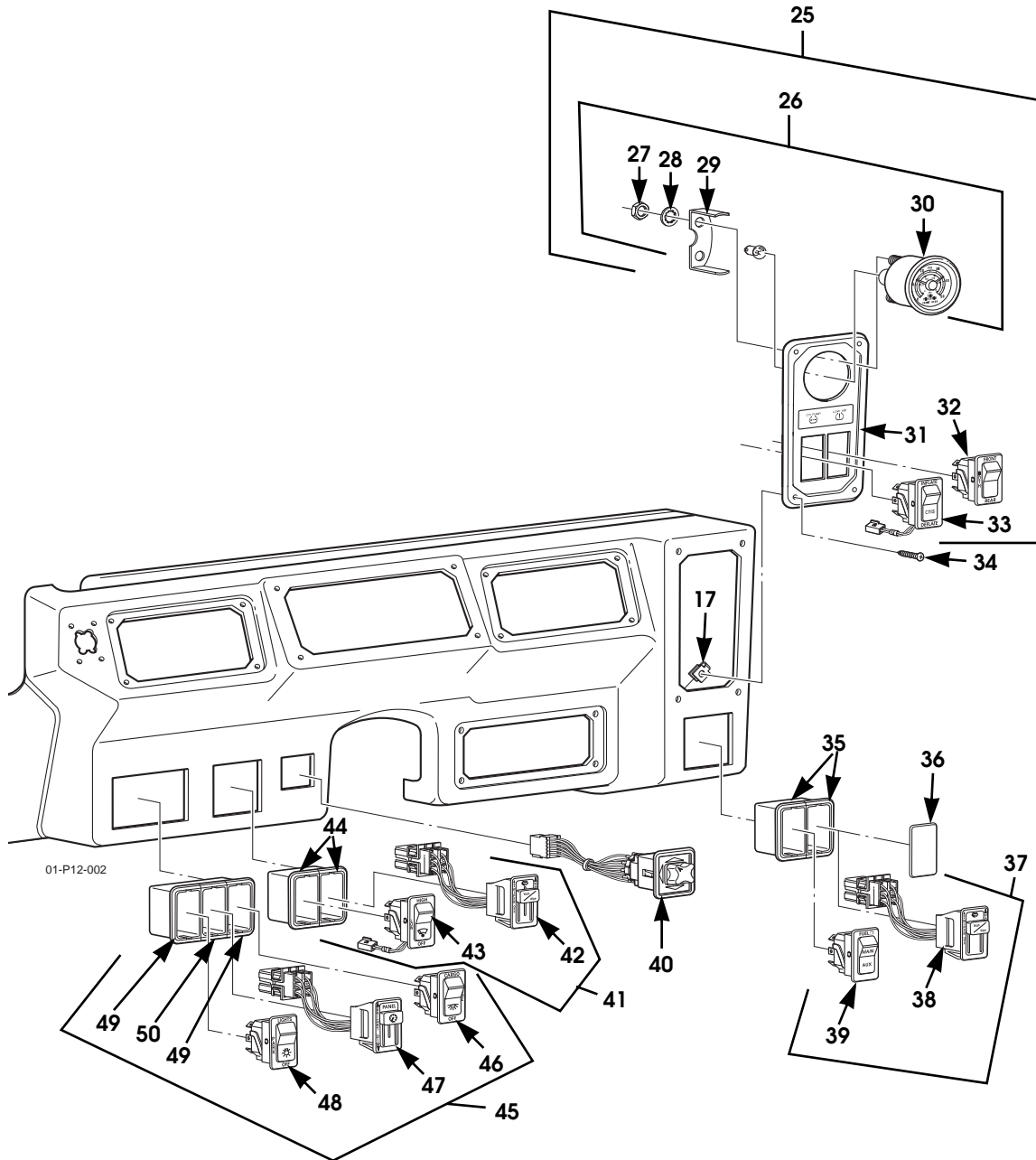

Figure 12-8. Instrument Panel Cluster  
(Sheet 2 of 2)

# 2001 HUMMER PARTS CATALOG

## ELECTRICAL 12-25

ITEM	PART NUMBER	DESCRIPTION	QTY
		<b>Figure 12-8. Instrument Panel Cluster</b>	
1	6003558	NOZZLE, defrost . . . . .	1
2	N/S	SCREW, #8 - 32 x 1/2, ZN . . . . .	4
3	6011559	MODULE ASSEMBLY, volt/oil. . . . .	1
4	S.I.A.	•MODULE, volt/oil . . . . .	1
5	5745391	•LENS . . . . .	1
6	5745392	•BEZEL . . . . .	1
7	N/S	SCREW, phcr, #8 - 32 x 3/4 . . . . .	16
8	6011555	MODULE ASSEMBLY, speedometer/tach, SEE NOTE 1 . . . . .	1
8	6011556	MODULE ASSEMBLY, speedometer/tach, SEE NOTE 2 . . . . .	1
8	6011557	MODULE ASSEMBLY, speedometer/tach, SEE NOTE 3 . . . . .	1
9	S.I.A.	•MODULE, speedometer/tach . . . . .	1
10	5745389	•LENS . . . . .	1
11	5745390	•BEZEL . . . . .	1
12	6011558	MODULE ASSEMBLY, fuel/temperature gauges . . . . .	1
13	5745392	•BEZEL . . . . .	1
14	5745391	•LENS . . . . .	1
15	S.I.A.	•MODULE, fuel/temperature gauges . . . . .	1
16	6011765	PANEL, blank. . . . .	1
17	6011568	SPEED NUT, J-type, #8. . . . .	16
18	5939270	PANEL, blank. . . . .	1
19	5939651P2	SCREW . . . . .	4
20	6000302	SPEED NUT, J-type, #10. . . . .	4
21	6007199	PLUG, instrument panel . . . . .	1
22	6011487	INSTRUMENT PANEL . . . . .	1
23	12341352	SPEED NUT, J-type, #8 - 32 . . . . .	4
24	6011636	HARNES ASSEMBLY, instrument panel. . . . .	1
25	6011764	MODULE ASSEMBLY and harness, CTIS tire pressure. . . . .	1
26	5745388	•GAUGE ASSEMBLY, CTIS tire pressure . . . . .	1
27	S.I.A.	••NUT . . . . .	2
28	S.I.A.	••LOCKWASHER . . . . .	2
29	S.I.A.	••MOUNTING BRACKET, CTIS panel . . . . .	1
30	S.I.A.	••GAUGE, CTIS tire pressure. . . . .	1
31	S.I.A.	•PANEL, CTIS. . . . .	1
32	6006604	•SWITCH, CTIS selector . . . . .	1
33	6006603	•SWITCH, CTIS inflate/deflate. . . . .	1
34	MS35206-347P2	SCREW . . . . .	4
35	6010666	BEZEL END . . . . .	2
36	6010667	PANEL, blank. . . . .	1
37	6010142	SWITCH ASSEMBLY, wiper/washer. . . . .	1
38	6010860	•SWITCH, wiper/washer . . . . .	1

# 2001 HUMMER PARTS CATALOG

## 12-26 ELECTRICAL

ITEM	PART NUMBER	DESCRIPTION	QTY
		<b>Figure 12-8. Instrument Panel Cluster (Cont'd)</b>	
39	6010143	•SWITCH, fuel tank, main/auxillary . . . . .	1
40	6010091	SWITCH, remote mirror. . . . .	1
41	6010142	SWITCH ASSEMBLY, wiper/washer . . . . .	1
42	6010141	•SWITCH, wiper/washer. . . . .	1
43	5939550	•SWITCH, wiper . . . . .	1
44	5939042	•BEZEL, switch bank, end . . . . .	2
45	6010146	SWITCH ASSEMBLY, lights/dimmer/dome 83, 84, 89, 91 . . . . .	1
45	6010147	SWITCH ASSEMBLY, lights/dimmer/dome 90 . . . . .	1
46	5939549	•SWITCH, dome lamp 83, 84, 89, 91 . . . . .	1
46	6000895	•SWITCH, dome lamp 90 . . . . .	1
47	6010145	•MODULE, panel light dimmer . . . . .	1
48	5939547	•SWITCH, head lamp. . . . .	1
49	5939042	•BEZEL, end, switch bank . . . . .	2
50	5939043	•BEZEL, center, switch bank . . . . .	1
		NOTE 1: ENGLISH/METRIC	
		NOTE 2: METRIC/ENGLISH	
		NOTE 3: METRIC/AUSTRALIAN	





# 2001 HUMMER PARTS CATALOG

## 12-28 ELECTRICAL

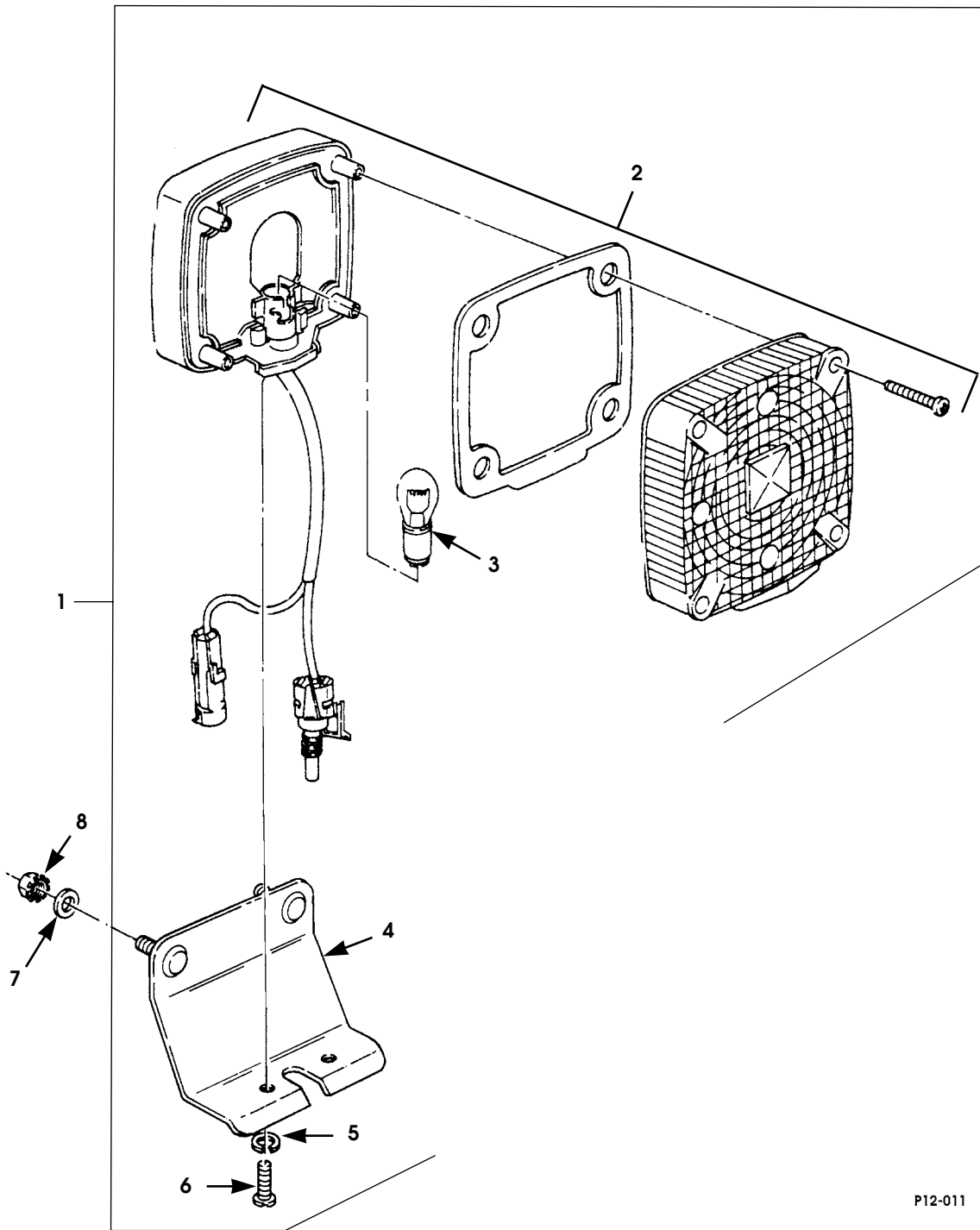

P12-011

Figure 12-9. Front Turn Signal Light and Mounting Hardware.

# 2001 HUMMER PARTS CATALOG

## ELECTRICAL 12-29

ITEM	PART NUMBER	DESCRIPTION	QTY
		<b>Figure 12-9. Front Turn Signal Light and Mounting Hardware.</b>	
1	5939092	LAMP ASSEMBLY, turn signal . . . . .	2
2	5939420	•LAMP, turn signal, amber. . . . .	2
3	N/S	•• BULB (trade #1157). . . . .	2
4	5939093B9	•BRACKET, front turn signal lamp. . . . .	2
5	N/S	•LOCKWASHER, spring, med, 1/4, ZN . . . . .	4
6	N/S	•BOLT, 1/4 - 20 x 1/2, Gr5. . . . .	4
7	N/S	WASHER, flat, 5/16 (.344"), CAD . . . . .	4
8	N/S	NUT AND LOCKWASHER ASSEMBLY, 5/16 - 18, Gr5, keps	4

# 2001 HUMMER PARTS CATALOG

## 12-30 ELECTRICAL

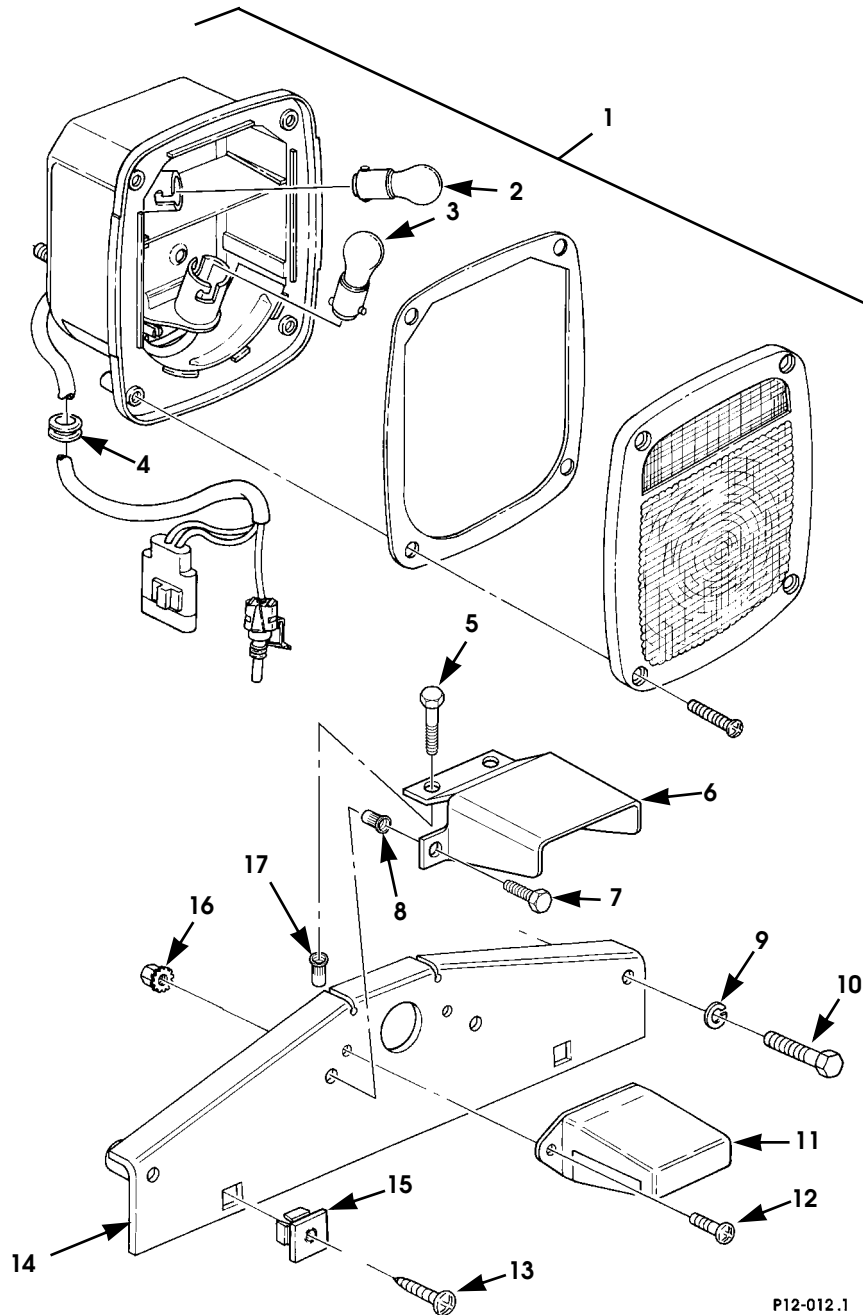

Figure 12-10. Rear Turn Signal Light/Taillight, License Plate Bracket, and Mounting Hardware.

# 2001 HUMMER PARTS CATALOG

## ELECTRICAL 12-31

ITEM	PART NUMBER	DESCRIPTION	QTY
		<b>Figure 12-10. Rear Turn Signal Light/Taillight, License Plate Bracket, and Mounting Hardware.</b>	
1	5939089	TAILLIGHT ASSEMBLY . . . . .	2
2	N/S	•BULB, backup (trade #1156). . . . .	1
3	N/S	•BULB, stop, turn, taillight (trade #1157) . . . . .	1
4	MS35489-41	•GROMMET, hole, 3/8", 1.25" . . . . .	1
5	N/S	SCREW, 1/4 - 20 x 1 1/4, protective bracket, from top	2
6	6009594	PROTECTIVE BRACKET, license plate lamp shield . . . . .	1
7	N/S	SCREW, 1/4 - 20 x 5/8, protective bracket, from rear . .	2
8	N/S	NUT INSERT, 1/4 - 20, grip range .080 - .165 . . . . .	2
9	N/S	LOCKWASHER, 1/4 . . . . .	2
10	N/S	SCREW, tapping, 1/4 - 20 x 1 1/4, ZN . . . . .	2
11	5937030	LAMP ASSEMBLY, license plate . . . . .	1
12	N/S	SCREW, phcr, #8 - 32 x 1/2, ZN . . . . .	2
13	N/S	SCREW, 1/4 - 28 x 5/8, ZN . . . . .	2
14	6009592B9	BRACKET ASSEMBLY, license plate mount . . . . .	1
15	5939483	NUT, square head grommet. . . . .	2
16	N/S	NUT AND LOCKWASHER ASSEMBLY, keps, #8 - 32 . . . . .	2
17	N/S	NUT INSERT, 1/4 - 20, grip range .080 - .260 . . . . .	2

# 2001 HUMMER PARTS CATALOG

## 12-32 ELECTRICAL

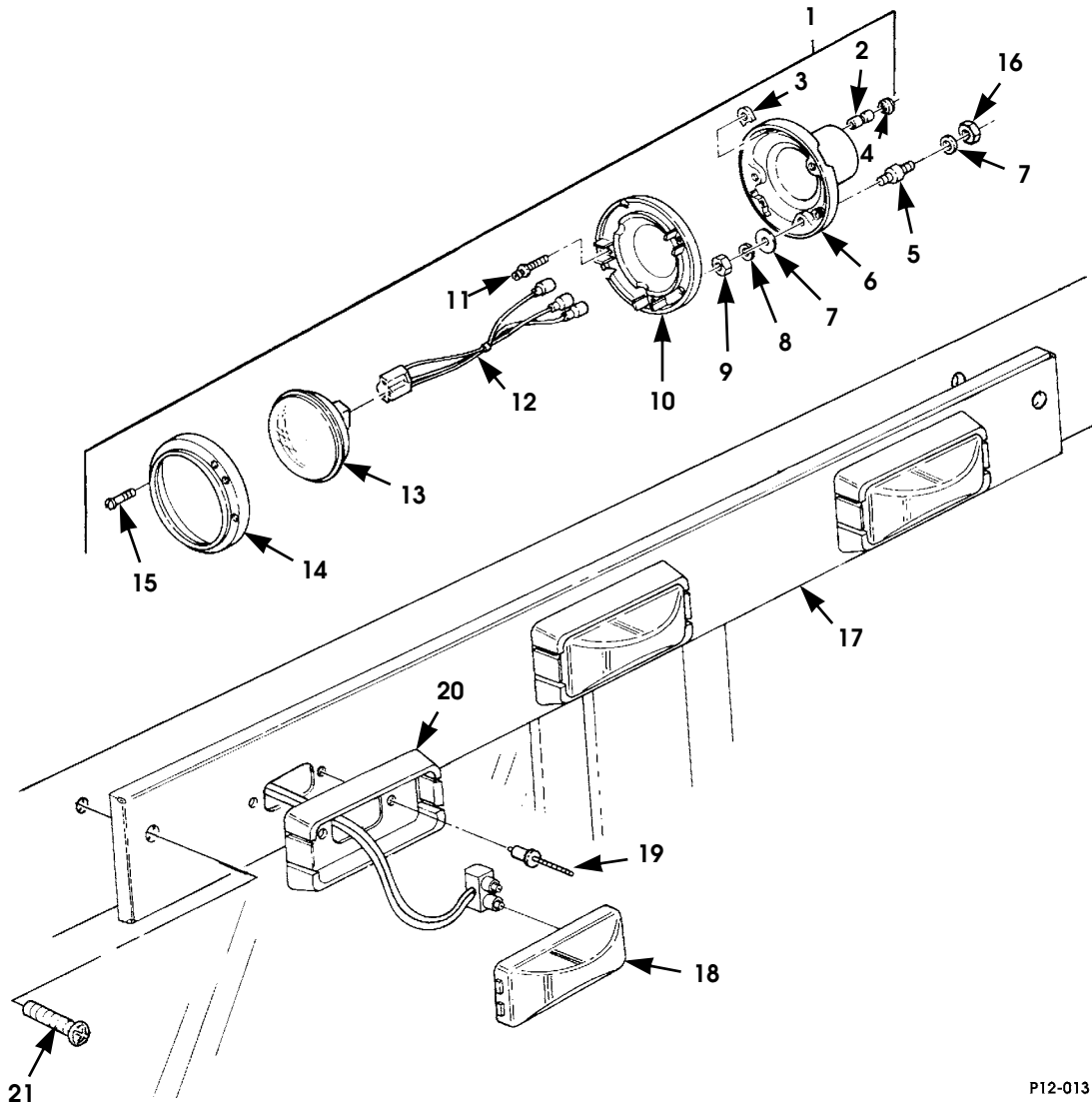

P12-013

Figure 12-11. Headlight Assembly and Running Lights.

# 2001 HUMMER PARTS CATALOG

## ELECTRICAL 12-33

ITEM	PART NUMBER	DESCRIPTION	QTY
		<b>Figure 12-11. Headlight Assembly and Running Lights.</b>	
1	5938841	HEADLIGHT ASSEMBLY . . . . .	2
2	8741492	•CONNECTOR, headlight . . . . .	3
3	8741435	•NUT . . . . .	2
4	8741442	•GROMMET . . . . .	3
5	12338607	•MOUNT . . . . .	3
6	5928841	•HEADLAMP HOUSING . . . . .	1
7	9414920	•WASHER, flat, 1/4, headlight assembly . . . . .	9
8	N/S	•LOCKWASHER, med, 1/4, ZN . . . . .	3
9	N/S	•NUT, 1/4 - 28, Gr5, CAD . . . . .	3
10	8741447	•HEADLAMP MOUNT ASSEMBLY . . . . .	1
11	7538146	•SCREW, head lamp . . . . .	2
12	5935897	•HARNES ASSEMBLY, jumper . . . . .	1
13	5938842	•LAMP, halogen . . . . .	1
14	8741446	•RETAINING RING . . . . .	1
15	8741437P2	•SCREW, headlight bezel . . . . .	3
16	N/S	LOCKNUT, w/washer, keps, 1/4 - 28, ZN, headlight assembly . . . . .	6
17	5937037P	BRACKET ASSEMBLY . . . . .	1
18	5937027	LAMP, yellow . . . . .	5
19	M24243/5-A404	RIVET . . . . .	10
20	5937024	BRACKET, lamp assembly mount . . . . .	5
21	N/S	SCREW, phcr, 1/4 - 20 x 1 1/4, CAD . . . . .	2

# 2001 HUMMER PARTS CATALOG

## 12-34 ELECTRICAL

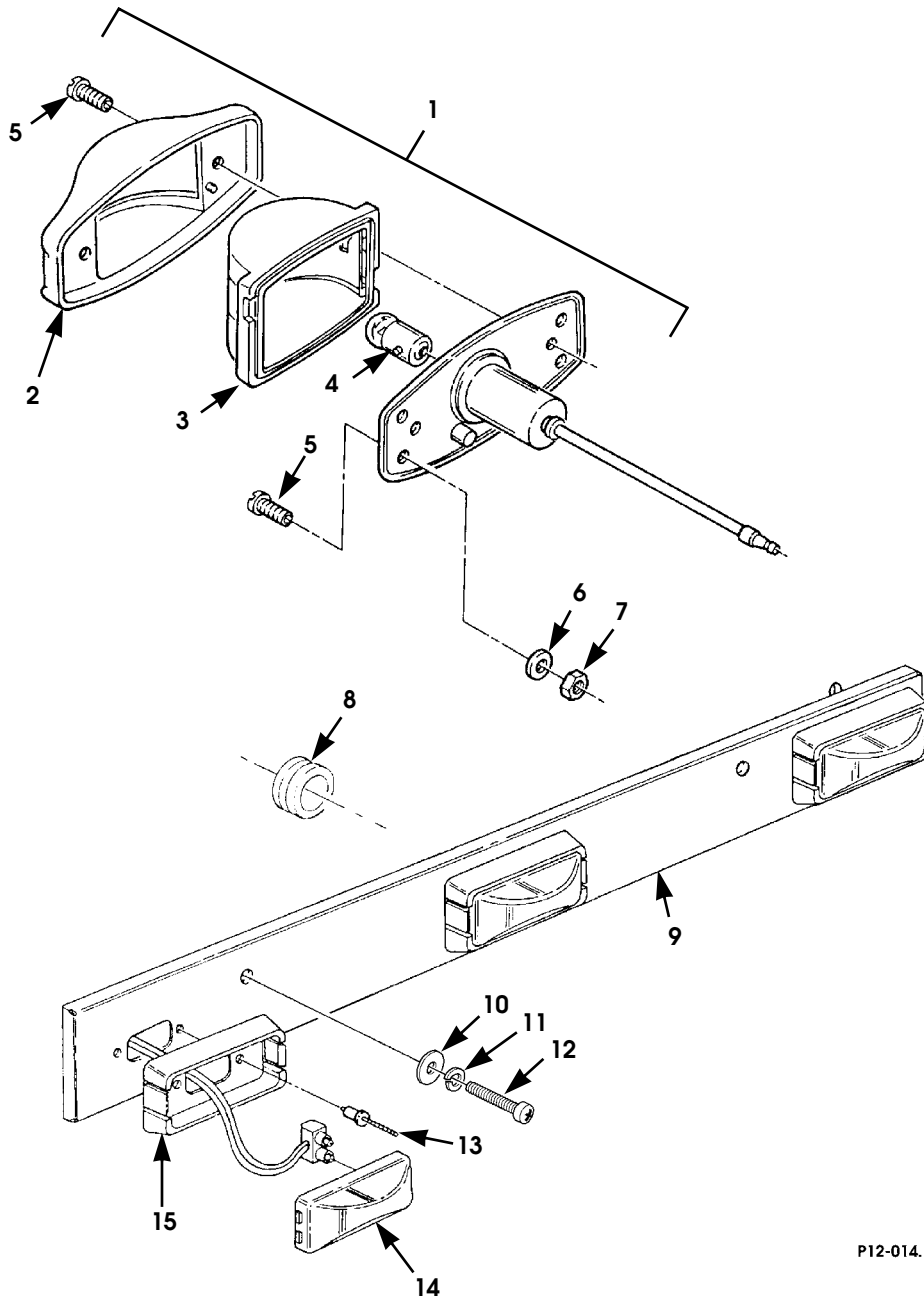

P12-014.2

Figure 12-12. Clearance Marker Light Assembly.

# 2001 HUMMER PARTS CATALOG

## ELECTRICAL 12-35

ITEM	PART NUMBER	DESCRIPTION	QTY
		<b>Figure 12-12. Clearance Marker Light Assembly.</b>	
1	5937035	LAMP, marker, rear . . . . .	2
1	5937036	LAMP, marker, front . . . . .	2
2	S.I.A.	•LAMP HOLDER . . . . .	4
3	MS35421-1	•LENS, light, amber, front . . . . .	2
3	MS35421-2	•LENS, light, red, rear . . . . .	2
4	S.I.A.	•BULB (trade #67) . . . . .	1
5	N/S	SCREW, #10-24 x .75" PH mach cad . . . . .	16
6	N/S	WASHER, flat, #10, CAD . . . . .	16
7	N/S	LOCKNUT, #10 - 24, Gr8, CAD . . . . .	16
8	6006453	GROMMET . . . . . 83, 89, 90	1
8	6006827	GROMMET . . . . . 84	1
8	6011071	GROMMET . . . . . 91	1
9	6007362P	BRACKET ASSEMBLY, rear . . . . .	1
10	N/S	WASHER, flat, 1/4 . . . . .	2
11	N/S	LOCKWASHER, 1/4 . . . . .	2
12	N/S	SCREW, phcr, 1/4 - 20 x 1 3/4, CAD . . . . .	2
13	M24243/5-A404	RIVET . . . . .	10
14	5937026	LAMP ASSEMBLY, red . . . . .	5
15	5937024	BRACKET, lens assembly mounting . . . . .	5



# 2001 HUMMER PARTS CATALOG

## 12-36 ELECTRICAL

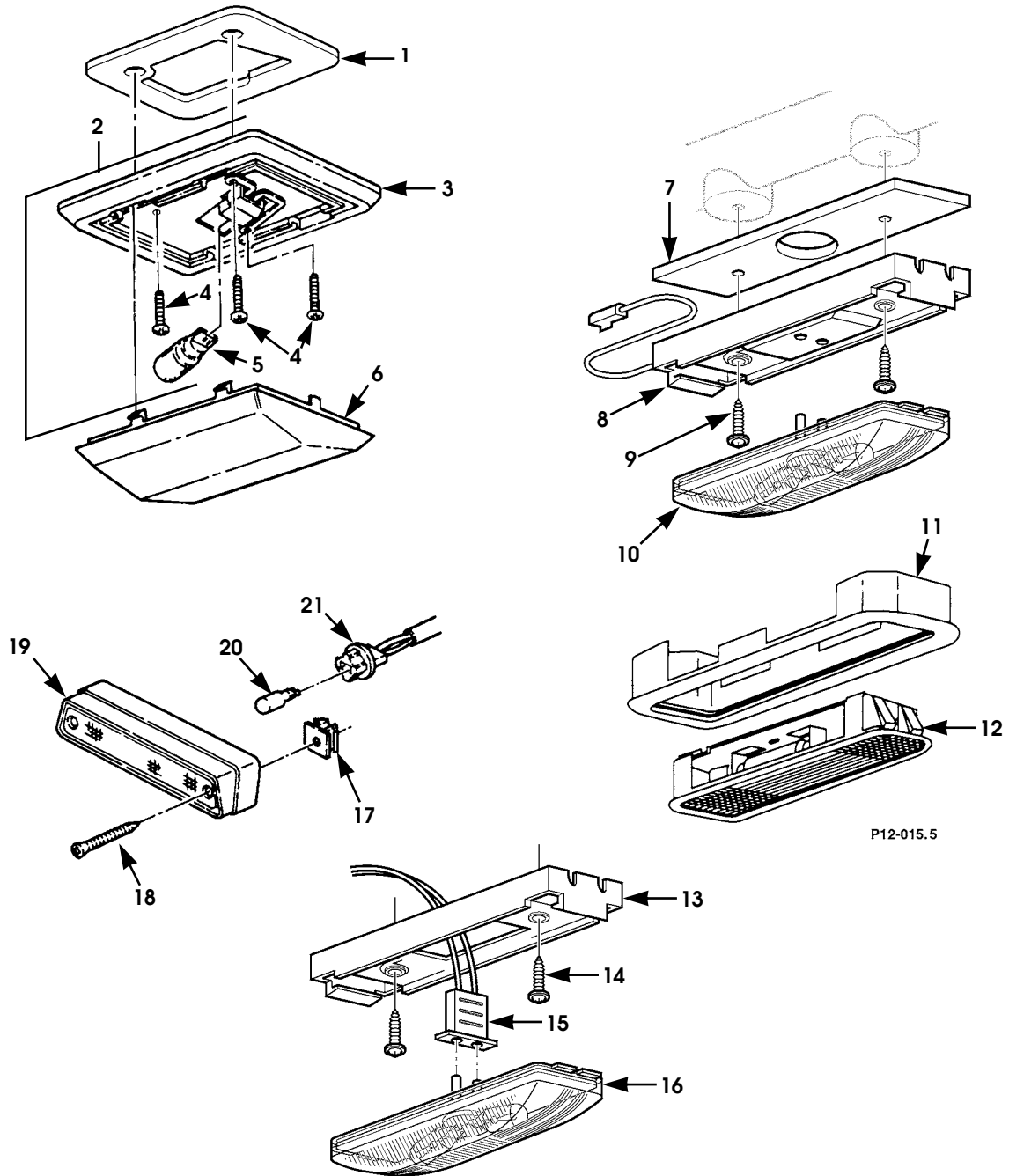

Figure 12-13. Interior Dome Lights.

# 2001 HUMMER PARTS CATALOG

## ELECTRICAL 12-37

ITEM	PART NUMBER	DESCRIPTION	QTY
		<b>Figure 12-13. Interior Dome Lights.</b>	
1	6003013	GASKET, dome light, overhead console, SEE NOTE 1 . . . 83, 84, 91	1
2	5939057	DOMELAMP ASSEMBLY, standard . . . . . 89	1
2	5939057	DOMELAMP ASSEMBLY, standard . . . . . 83, 91	2
2	5939057	DOMELAMP ASSEMBLY, standard . . . . . 84	3
3	S.I.A.	BASE, dome light . . . . . 89	1
3	S.I.A.	BASE, dome light . . . . . 83, 91	2
3	S.I.A.	BASE, dome light . . . . . 84	3
4	S.I.A.	•SCREW . . . . . 89	3
4	S.I.A.	•SCREW . . . . . 83, 91	6
4	S.I.A.	•SCREW . . . . . 84	9
5	S.I.A.	•LAMP (trade #912) . . . . . 89	1
5	S.I.A.	•LAMP (trade #912) . . . . . 83, 91	2
5	S.I.A.	•LAMP (trade #912) . . . . . 84	3
6	5939652	LENS, dome lamp . . . . . 89	1
6	5939652	LENS, dome lamp . . . . . 83, 91	2
6	5939652	LENS, dome lamp . . . . . 84	3
7	6009494	SUPPORT, dome lamp . . . . . 90	1
8	6009496	BASE, dome light . . . . . 90	1
9	N/S	SCREW, tapping, #8 - 32 x 3/4. . . . . 90	2
10	6009495	DOMELAMP ASSEMBLY, . . . . . 90	1

# 2001 HUMMER PARTS CATALOG

## 12-38 ELECTRICAL

ITEM	PART NUMBER	DESCRIPTION	QTY
		<b>Figure 12-13. Interior Dome Lights. (Cont'd)</b>	
11	6004087	BEZEL, map light . . . . . 89	2
11	6004087	BEZEL, map light . . . . . 83, 84, 91	4
12	6004088	LIGHT, assembly, map . . . . . 89	2
12	6004088	LIGHT, assembly, map . . . . . 83, 84, 91	4
13	6011035	BASE, dome light . . . . . 91	2
14	S.I.A.	SCREW, tapping, #8 - 32 x 1 3/4 . . . . . 91	4
15	6011057	HARNES, rear door jumper . . . . . 91	1
16	6009495	DOM LAMP ASSEMBLY . . . . . 91	2
17	5939659	GROMMET . . . . . 83, 89	2
18	S.I.A.	SCREW, tapping, #8 - 32 x 1 1/2 . . . . . 83, 89	2
19	6000894	CARGO LAMP ASSEMBLY . . . . . 83, 89	1
20	S.I.A.	LAMP (trade #912) . . . . . 83, 89	1
21	6000893	WIRING AND SOCKET ASSEMBLY . . . . . 83, 89	1
		NOTE 1: FOR USE ON VEHICLES WITH DELUXE RADIO	



# 2001 HUMMER PARTS CATALOG

## 12-40 ELECTRICAL

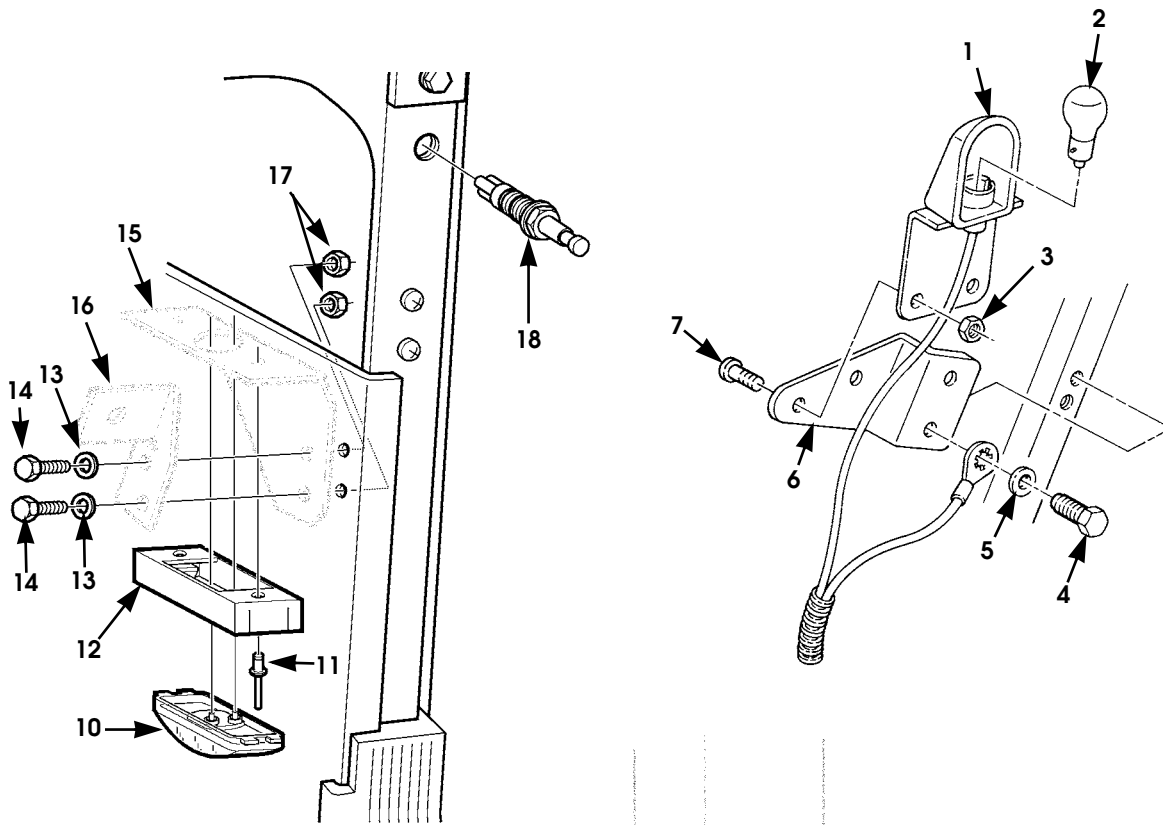

PASSENGER'S SIDE

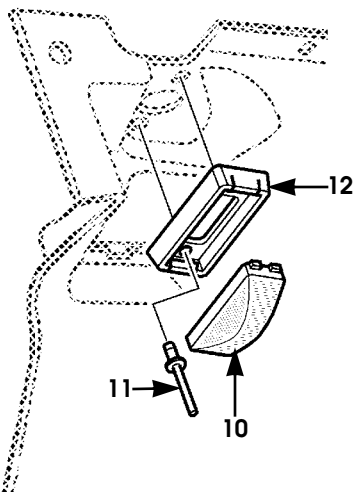

DRIVER'S SIDE

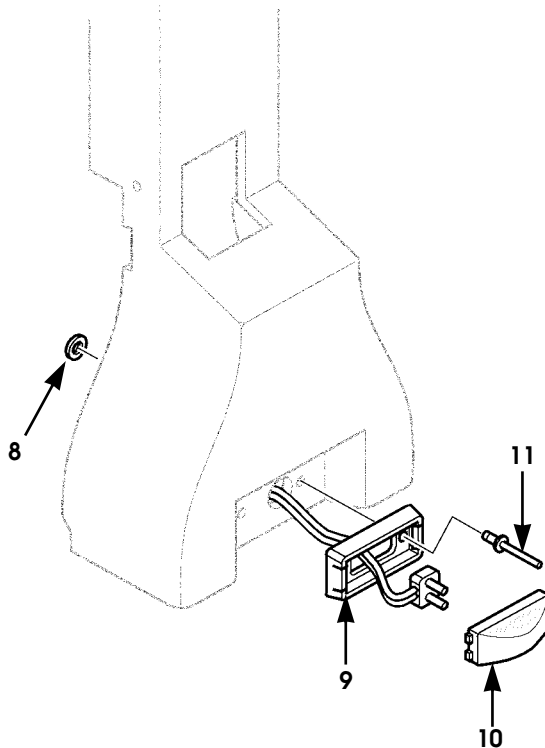

P12-016.2

Figure 12-14. Interior Courtesy Lights, Underhood Light, and Door Jamb Switch

# 2001 HUMMER PARTS CATALOG

## ELECTRICAL 12-41

ITEM	PART NUMBER	DESCRIPTION	QTY
		<b>Figure 12-14. Interior Courtesy Lights, Underhood Light, and Door Jamb Switch</b>	
1	5939456	LAMP ASSEMBLY, underhood . . . . .	1
2	N/S	BULB (trade #93) . . . . .	1
3	271169	NUT, #10 - 32, underhood lamp bracket . . . . .	2
4	N/S	SCREW, tapping, #10 - 32 x 5/8. . . . .	2
5	MS27183-8	WASHER . . . . .	2
6	5939819	BRACKET, underhood lamp . . . . .	1
7	N/S	SCREW, #10 - 32 x 1/2, underhood lamp bracket. . . . .	2
8	MS27183-8	WASHER . . . . .	2
9	5937024	BRACKET, lamp assembly mounting . . . . .	1
10	5939309	LAMP ASSEMBLY . . . . .	1
11	N/S	RIVET, .125 Dia, blind . . . . .	2
12	5937024	BRACKET, lamp assembly mounting . . . . .	1
13	N/S	WASHER, flat, hardened, 1/4, type B . . . . .	2
14	N/S	BOLT, 1/4 - 20 x 1 1/2, Gr8, CAD . . . . .	2
15	6000093B9	BRACKET, courtesy lamp mounting . . . . .	1
16	6009524B9	BRACKET, closeout panel . . . . .	1
17	N/S	WELDNUT, 1/4 - 20, Gr8, CAD . . . . .	2
18	5939088	SWITCH, door jamb . . . . .	4
		83, 90	
18	5939088	SWITCH, door jamb . . . . .	2
		89	
18	5939088	SWITCH, door jamb . . . . .	5
		84, 91	

# 2001 HUMMER PARTS CATALOG

## 12-42 ELECTRICAL

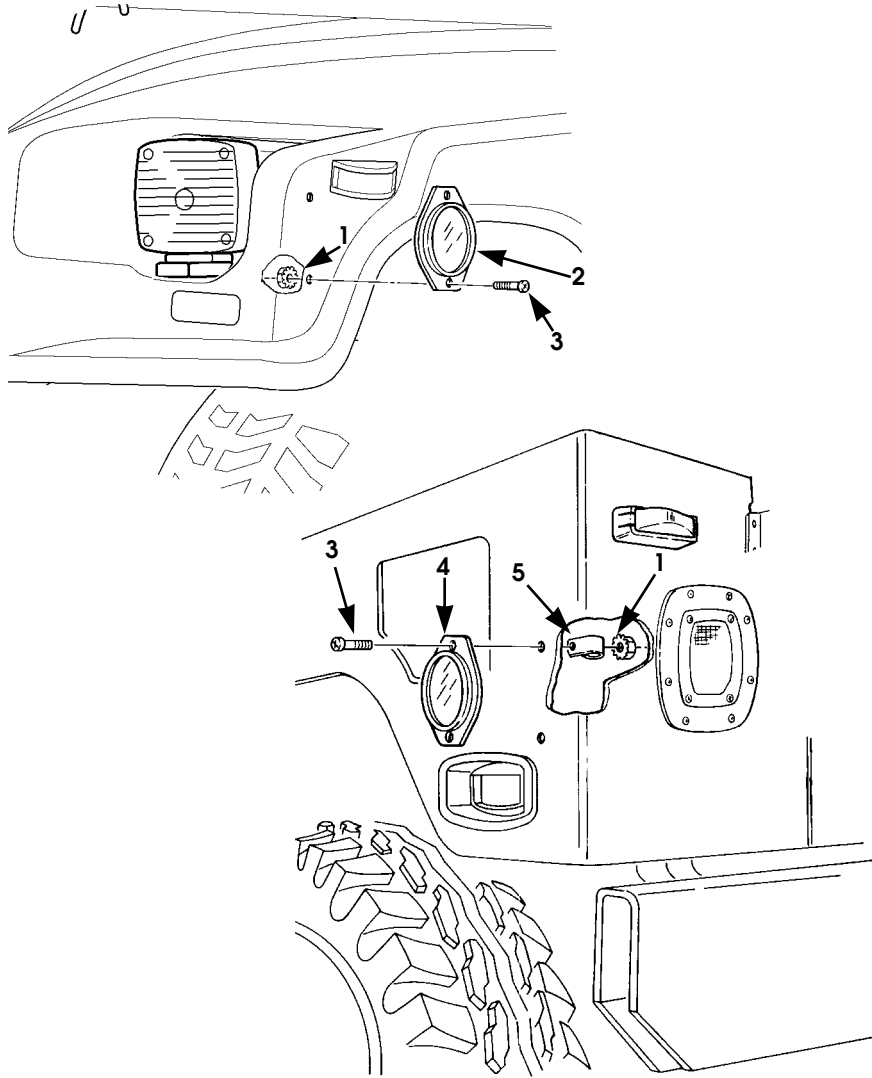

P12-017 .1

*Figure 12-15. Reflectors.*

# 2001 HUMMER PARTS CATALOG

## ELECTRICAL 12-43

ITEM	PART NUMBER	DESCRIPTION	QTY
		<b>Figure 12-15. Reflectors.</b>	
1	N/S	LOCKNUT AND WASHER ASSEMBLY, keps, 1/4 - 20, reflector mounting .....	8
2	5935715B2	AMBER REFLECTOR, front, side .....	2
3	N/S	SCREW, phcr, 1/4 - 20 x 5/8, ZN .....	8
4	5935714B2	RED REFLECTOR, rear, side. ....	2
5	MS21333-99	CLAMP, tube .....	4



# 2001 HUMMER PARTS CATALOG

## 12-44 ELECTRICAL

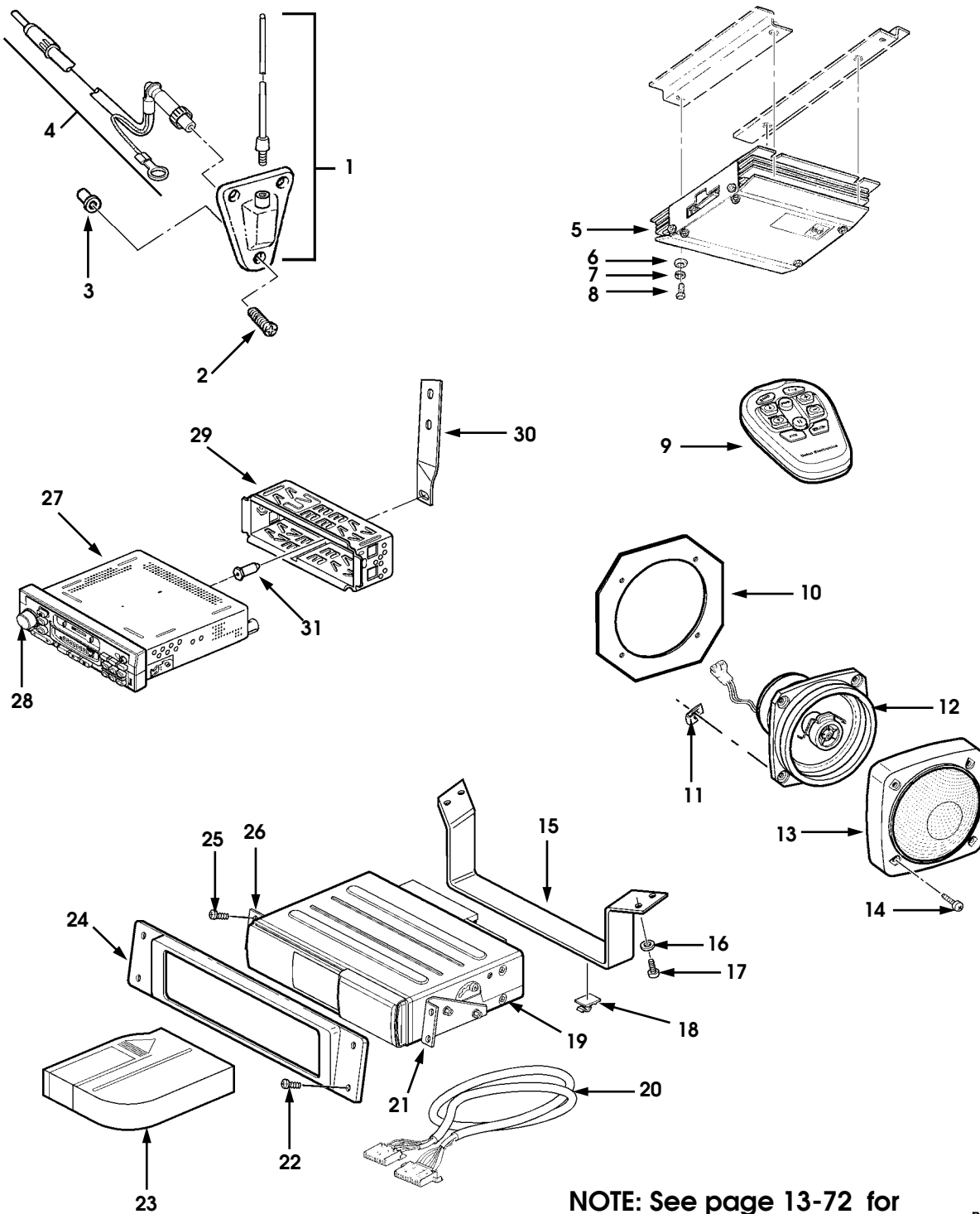

**NOTE: See page 13-72 for radio noise suppression filter.**

P12-066.4

*Figure 12-16. Stereo, Speakers, and Mounting Hardware, Standard and Monsoon (Delco).  
(Sheet 1 of 2)*

# 2001 HUMMER PARTS CATALOG

ELECTRICAL 12-45

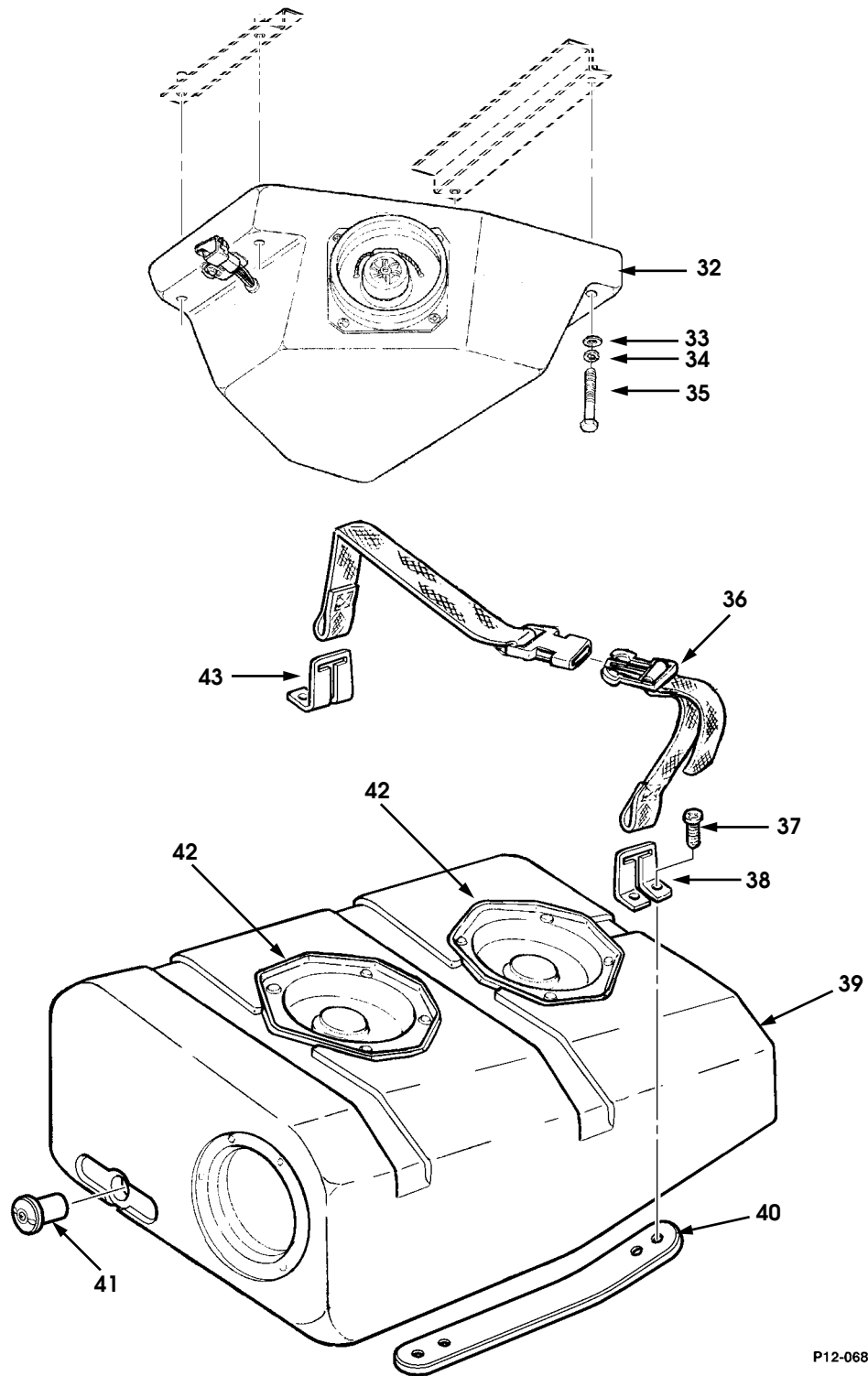

P12-068 .1

Figure 12-16. Stereo, Speakers, and Mounting Hardware, Standard and Monsoon.  
(Sheet 2 of 2)

# 2001 HUMMER PARTS CATALOG

## 12-46 ELECTRICAL

ITEM	PART NUMBER	DESCRIPTION	QTY
		<b>Figure 12-16. Stereo, Speakers, and Mounting Hardware, Standard and Monsoon (Delco).</b>	
1	6009394	ANTENNA AND BASE ASSEMBLY . . . . .	1
2	N/S	SCREW, ohcr, #8 - 32 x 1/2, ZN, radio antenna base . . . . .	3
3	6000337	NUT INSERT . . . . .	1
4	6009395	CABLE ASSEMBLY, antenna-to-radio . . . . .	1
5	6010850	AMPLIFIER, Monsoon . . . . . 83, 84, 90	1
6	N/S	WASHER, flat, #10, amplifier . . . . .	4
7	N/S	WASHER, lock, #10, med, ZN, amplifier . . . . .	4
8	MS51849-76	BOLT . . . . .	1
9	5744737	REMOTE CONTROL . . . . .	1
10	6009187	BACKING PLATE, speaker . . . . . 90	2
11	12341352	J-CLIP (four for each speaker) . . . . .	4
12	6009152	SPEAKER, 5 1/2" coaxial, standard system . . . . . 89	2
12	6009152	SPEAKER, 5 1/2" coaxial, standard system . . . . . 83, 84, 90	4
12	6009152	SPEAKER, 5 1/2" coaxial, Monsoon system . . . . . 83, 84	6
13	6009153	SPEAKER COVER, standard . . . . . 89	2
13	6009153	SPEAKER COVER, standard . . . . . 83, 84, 90	4
13	6009154	SPEAKER COVER, Monsoon . . . . . 83, 84	6
14	N/S	SCREW, phcr, #8 - 32 x 1 1/4, CAD (four for each speaker cover) . . . . .	4
15	6010786	BRACKET, CD changer, front, SEE NOTE 1 . . . . .	1
16	N/S	WASHER, flat, #10, bracket, CD changer . . . . .	4
17	N/S	SCREW, phcr, #10 - 32 x 3/4, SEE NOTE 1 . . . . .	4
18	6001543	CLIP, CD changer cable, SEE NOTE 1 . . . . .	2
19	6010797	CD CHANGER ASSEMBLY, SEE NOTE 1 . . . . .	1
20	6011001	•CABLE, CD changer . . . . .	1
21	6010788	BRACKET, CD changer, right, SEE NOTE 1 . . . . .	1
22	N/S	SCREW, oval head, #10 - 32 x 3/4, SEE NOTE 1 . . . . .	4
23	5745149	MAGAZINE, 6-CD, SEE NOTE 1 . . . . .	1
24	6010784	BEZEL, CD changer, SEE NOTE 1 . . . . .	1
25	N/S	SCREW, #10 - 16 x 7/8 . . . . .	4
26	6010787	BRACKET, CD changer, left, SEE NOTE 1 . . . . .	1

# 2001 HUMMER PARTS CATALOG

## ELECTRICAL 12-47

ITEM	PART NUMBER	DESCRIPTION	QTY
		<b>Figure 12-16. Stereo, Speakers, and Mounting Hardware, Standard and Monsoon (Delco).</b>	
27	6009145	RADIO HEAD, United States, standard . . . . .	1
27	6009146	RADIO HEAD, United States, Monsoon . . . . . 83, 84	1
27	6009147	RADIO HEAD, Middle East, standard and Monsoon . . . . .	1
27	6009149	RADIO HEAD, Australian, standard and Monsoon . . . . .	1
27	6009380	RADIO HEAD, Japanese, standard and Monsoon. . . . .	1
28	5745212	•KNOB, volume control, standard and Monsoon . . . . .	1
29	N/S	•SLEEVE, Delco radio, standard and Monsoon . . . . .	1
30	6009435	BRACKET, radio support . . . . .	1
31	6009434	BUSHING, radio, rear . . . . .	1
32	6009135	OVERHEAD CONSOLE SPEAKER ENCLOSURE, Monsoon 83, 84	1
33	N/S	WASHER, flat, #10, overhead console speaker . . . . . enclosure	4
34	N/S	WASHER, lock, #10, med, ZN, overhead console speaker	4
35	N/S	BOLT, 1/4 - 20 x 2 1/4 . . . . .	4
36	6009173	STRAP, subwoofer, Monsoon . . . . . 83, 84	2
37	N/S	SCREW, phcr, #10 - 24 x 3/4. . . . .	8
38	6009172	BRACKET, subwoofer, Monsoon . . . . . 83, 84	4
39	6009151	SUBWOOFER, Monsoon . . . . . 83, 84	1
40	6009803	PANEL, closeout, subwoofer mounting . . . . . 83, 84	1
41	12340000	DRAIN PLUG, subwoofer, Monsoon . . . . . 83, 84	1
42	5744822	•SPEAKER, 6" subwoofer . . . . . 83, 84	2
NOTE 1: PART OF CD CHANGER KIT P/N 5745336.			

# 2001 HUMMER PARTS CATALOG

## 12-48 ELECTRICAL

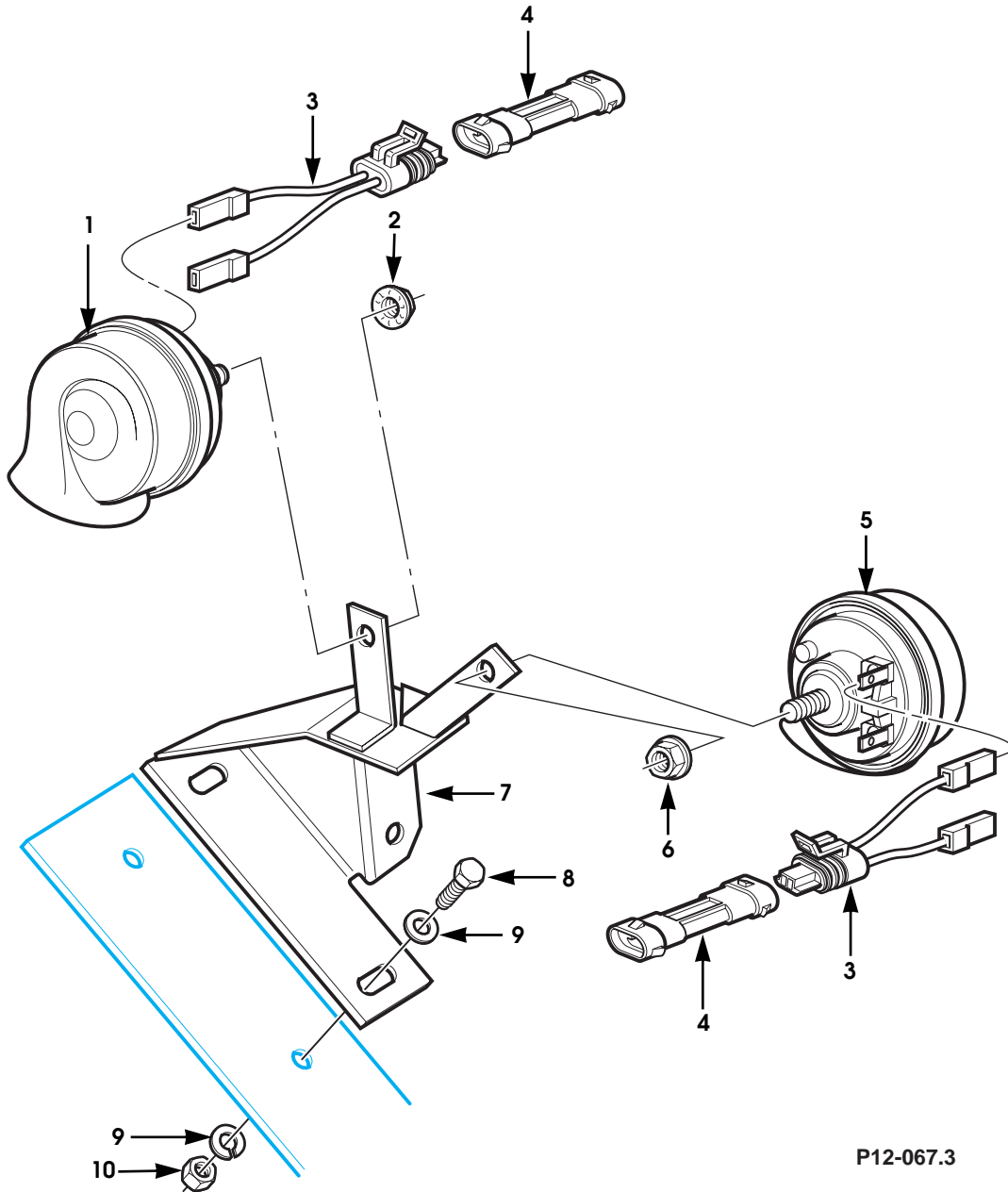

P12-067.3

Figure 12-17. Dual Horns.

# 2001 HUMMER PARTS CATALOG

## ELECTRICAL 12-49

ITEM	PART NUMBER	DESCRIPTION	QTY
		<b>Figure 12-17. Dual Horns.</b>	
1	6010950	HORN, 400 Hz . . . . .	1
2	S.I.A.	•LOCKNUT . . . . .	1
3	6010952	JUMPER, horn . . . . .	2
4	6010951	ADAPTER, female to female . . . . .	2
5	6010949	HORN, 500 Hz . . . . .	1
6	S.I.A.	•LOCKNUT . . . . .	1
7	6007345	BRACKET ASSEMBLY, horn/cruise actuator mounting .	1
8	N/S	BOLT, 1/4 - 20 x 3/4, Gr5, CAD . . . . .	2
9	N/S	WASHER, flat, hard, 1/4, type B . . . . .	4
10	N/S	LOCKNUT, 1/4 - 20, Gr8 . . . . .	2



# 2001 HUMMER PARTS CATALOG

ELECTRICAL 12-51

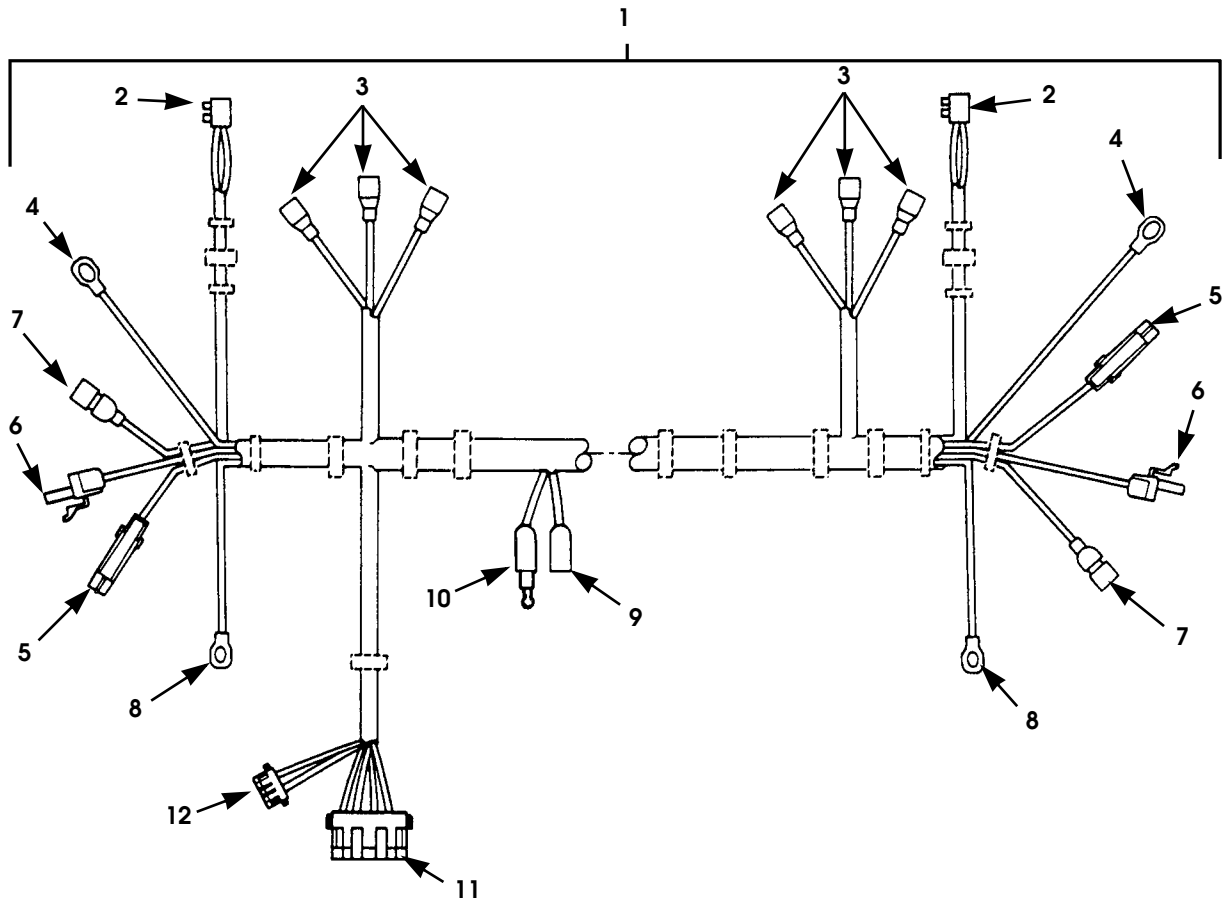







					
VIEW 2	VIEW 3	VIEW 4	VIEW 5	VIEW 6	VIEW 7
					
VIEW 8	VIEW 9	VIEW 10	VIEW 11	VIEW 12	



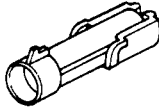
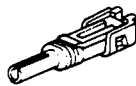

Figure 12-18. Hood Wiring Harness  
(Sheet 1 of 2).

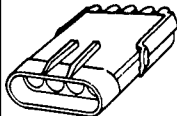
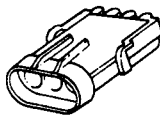
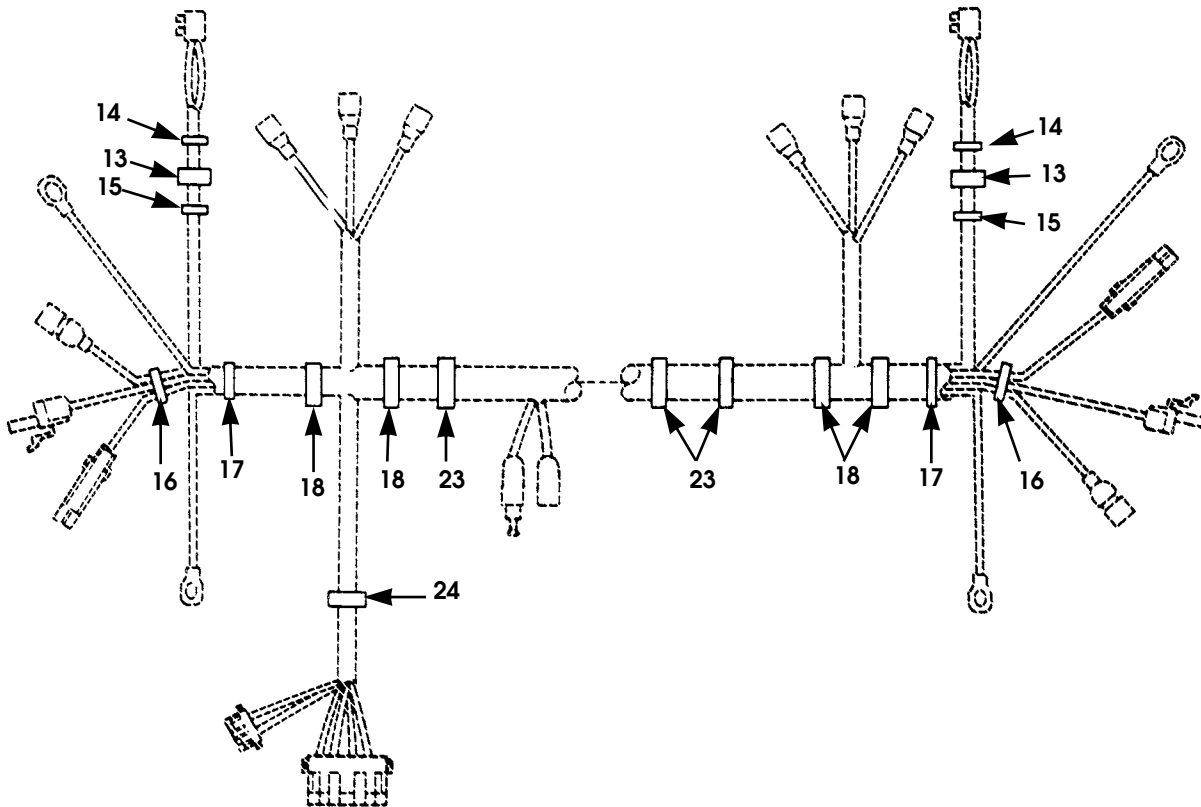

# 2001 HUMMER PARTS CATALOG

## 12-52 ELECTRICAL

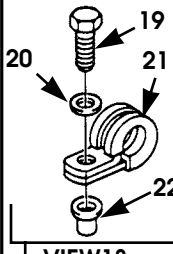
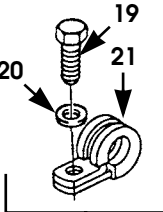
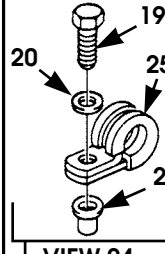

 <p>VIEW 13</p>	 <p>VIEW 14</p>	 <p>VIEW 15</p>	 <p>VIEW 16</p>	 <p>VIEW 17</p>	 <p>L VIEW 18</p>
 <p>VIEW 23</p>	 <p>L VIEW 24</p>				

P12-022.1

Figure 12-18. Hood Wiring Harness  
(Sheet 2 of 2).

# 2001 HUMMER PARTS CATALOG

## ELECTRICAL 12-53

ITEM	PART NUMBER	DESCRIPTION	QTY
		<b>Figure 12-18. Hood Wiring Harness</b>	
1	5936598	HOOD WIRING HARNESS . . . . .	1
2	5937021	•CONNECTOR, clearance lamps . . . . .	2
3	MS27142-2	•CONNECTOR PLUG, left and right head lamp. . . . .	6
4	N/S	•TERMINAL LUG, parking lamp ground. . . . .	2
5	5939236	•CONNECTOR PLUG, turn signal lamp . . . . .	2
6	5939237	•CONNECTOR PLUG, park light . . . . .	2
7	MS27144-2	•CONNECTOR PLUG, marker lamp . . . . .	2
8	N/S	•TERMINAL LUG, marker lamp ground . . . . .	2
9	N/S	•CONNECTOR PLUG, under hood lamp. . . . .	1
10	N/S	•CONNECTOR, under hood lamp. . . . .	1
11	5995732	•CONNECTOR PLUG, to body harness . . . . .	1
12	5939582	•CONNECTOR PLUG, under hood lamp. . . . .	1
13	MS21333-99	CLAMP, wiring harness, 1/4" . . . . .	2
14	MS35489-10S	GROMMET, wiring harness . . . . .	2
15	MS35489-39S	GROMMET, wiring harness . . . . .	2
16	12340573	CLIP, harness mounting . . . . .	2
17	MS35489-48S	GROMMET, wiring harness . . . . .	2
18	N/S	1/2" CLAMP ASSEMBLY, w/wellnut. . . . .	3
19	N/S	•SCREW, harness clamps 1/4-20 x 7/8" GR 5 cad SEE NOTE 1 . . . . .	6
20	N/S	•WASHER, harness clamps 1/4" cad, sae flat ,SEE NOTE 1 . . . . .	6
21	N/S	•CLAMP, wiring harness 1/2" cushioned, SEE NOTE 2 . . . . .	4
22	12339397-4	•WELLNUT, wiring harness, SEE NOTE 3 . . . . .	5
23	N/S	1/2" CLAMP ASSEMBLY w/o wellnut. . . . .	2
24	N/S	3/8" CLAMP ASSEMBLY . . . . .	1
25	N/S	•CLAMP, wiring harness, 3/8" cushioned. . . . .	1
		NOTE 1: USE ONE PER ITEMS 18, 23, & 24.	
		NOTE 2: USE ONE PER ITEMS 18 & 23.	
		NOTE 3: USE ONE PER ITEMS 18 & 24.	

# 2001 HUMMER PARTS CATALOG

## 12-54 ELECTRICAL

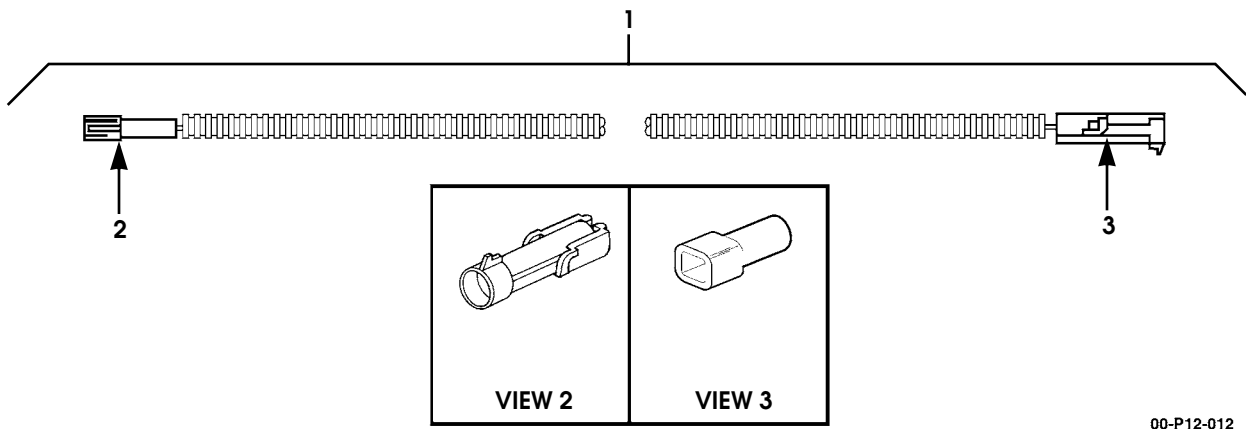

00-P12-012

Figure 12-19. Roof Wiring Harness, Open Top

# 2001 HUMMER PARTS CATALOG

## ELECTRICAL 12-55

ITEM	PART NUMBER	DESCRIPTION	QTY
		<b>Figure 12-19. Roof Wiring Harness, Open Top</b>	
1	6010672	JUMPER HARNESS ASSEMBLY, dome lamp, open body	1
2	6004020	•CONNECTOR, jumper harness to dome lamp . . . . .	1
3	5939237	•CONNECTOR, jumper harness to roof wiring harness	1

# 2001 HUMMER PARTS CATALOG

## 12-56 ELECTRICAL

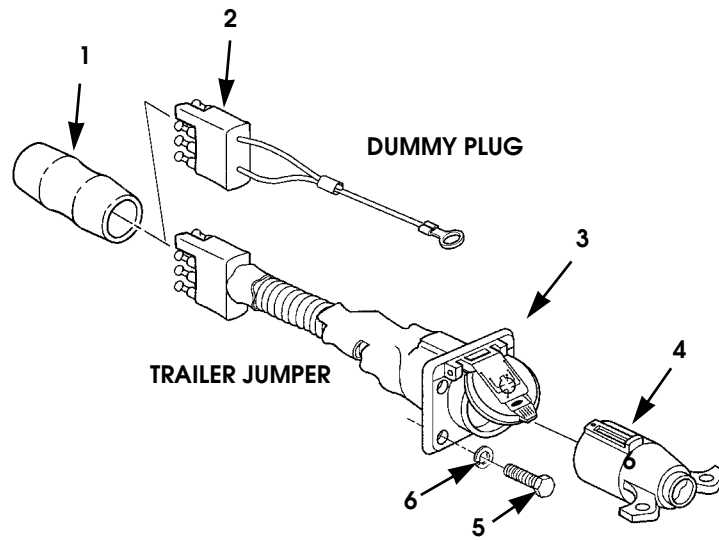

Figure 12-20. Trailer Towing Wiring.

# 2001 HUMMER PARTS CATALOG

## ELECTRICAL 12-57

ITEM	PART NUMBER	DESCRIPTION	QTY
		<b>Figure 12-20. Trailer Towing Wiring.</b>	
1	6002920	SHRINK TUBING . . . . .	1
2	5937211	PLUG, dummy, trailer jumper harness, with tether . . . .	1
3	6008780	TRAILER JUMPER HARNESS ASSEMBLY . . . . .	1
4	6008827	HARNESS ASSEMBLY, trailer plug . . . . .	1
5	N/S	SCREW, mach, 1/4 - 20 x 1, Gr8, CAD . . . . .	4
6	N/S	LOCKWASHER, med, 1/4, ZN . . . . .	4

# 2001 HUMMER PARTS CATALOG

## 12-58 ELECTRICAL

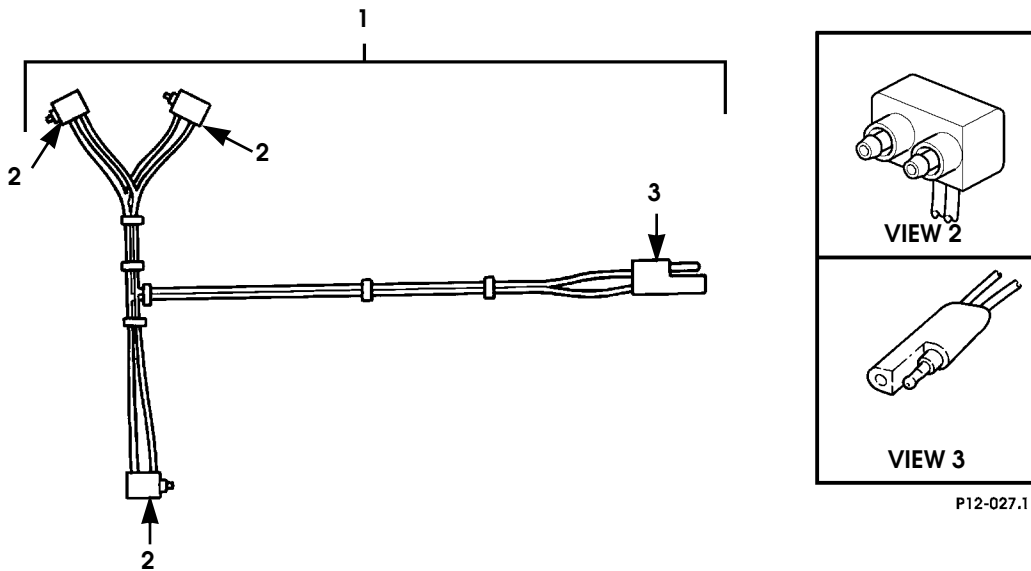

P12-027.1

Figure 12-21. Identification Lamp Assembly Jumper.

# 2001 HUMMER PARTS CATALOG

## ELECTRICAL 12-59

ITEM	PART NUMBER	DESCRIPTION	QTY
		<b>Figure 12-21.</b> <b>Identification Lamp Assembly Jumper.</b>	
1	5936493	IDENTIFICATION LAMP JUMPER HARNESS, front . . . . .	1
1	6000082	IDENTIFICATION LAMP JUMPER HARNESS, rear . . . . .	1
2	5937039	•CONNECTOR, lamp. . . . .	3
3	N/S	•INSULATOR, mold on . . . . .	1



# 2001 HUMMER PARTS CATALOG

## 12-60 ELECTRICAL

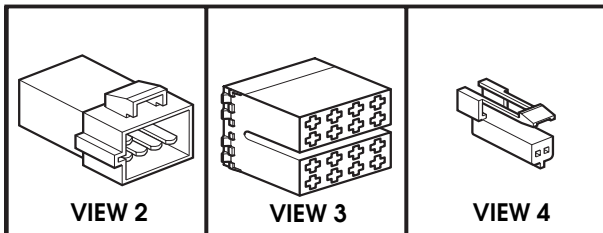
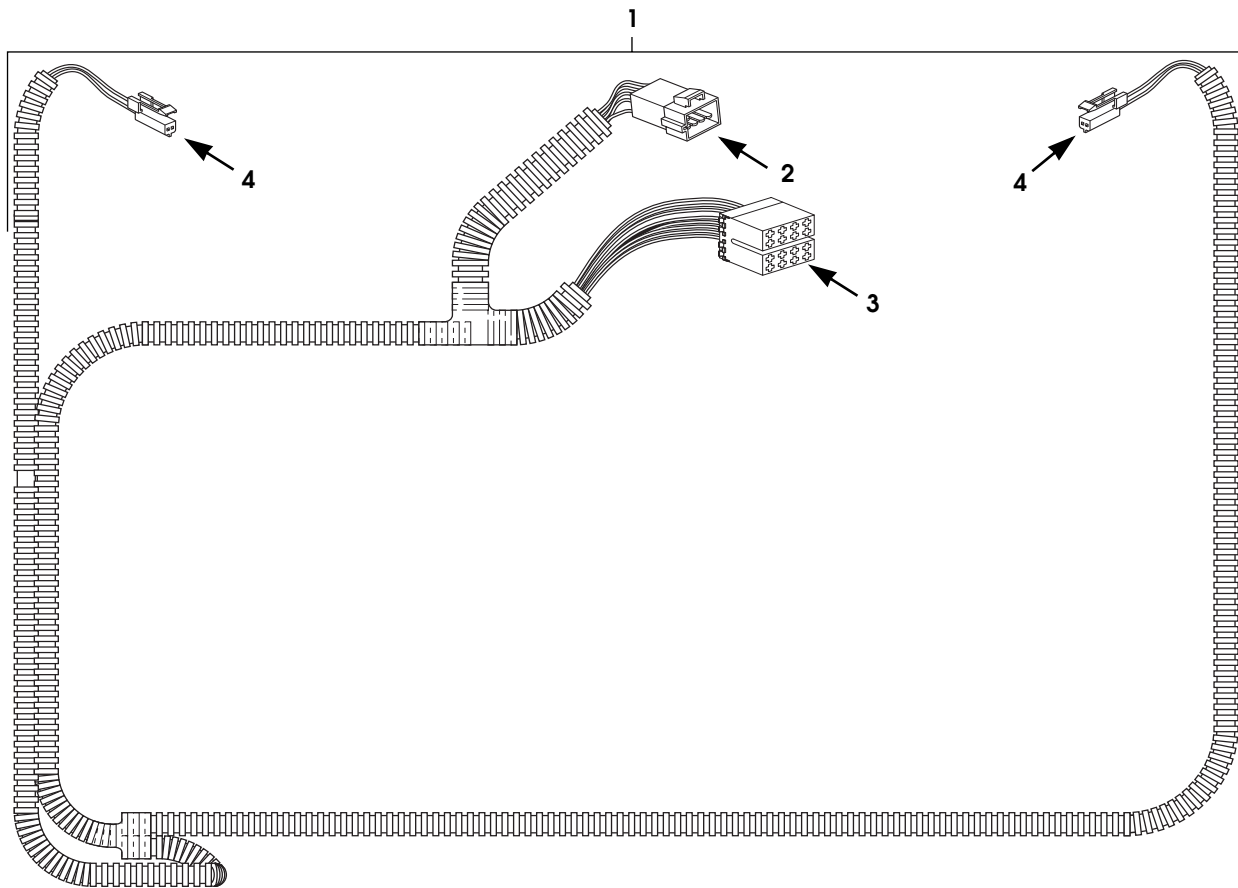

00-P12-006

Figure 12-22. Delco Standard Stereo Harness Two-Speaker, Two-Door, Model 89.

# 2001 HUMMER PARTS CATALOG

## ELECTRICAL 12-61

ITEM	PART NUMBER	DESCRIPTION	QTY
		<b>Figure 12-22. Delco Standard Stereo Harness Two-Speaker, Two-Door, Model 89.</b>	
1	6011012	HARNESS ASSEMBLY, Delco standard stereo, two-speaker. . . . .	1
2	6008670	•CONNECTOR, 8-way, body harness . . . . .	1
3	N/S	•CONNECTOR, 16-way, radio . . . . .	1
4	6009363	•CONNECTOR, 2-way, speaker . . . . .	2

# 2001 HUMMER PARTS CATALOG

## 12-62 ELECTRICAL

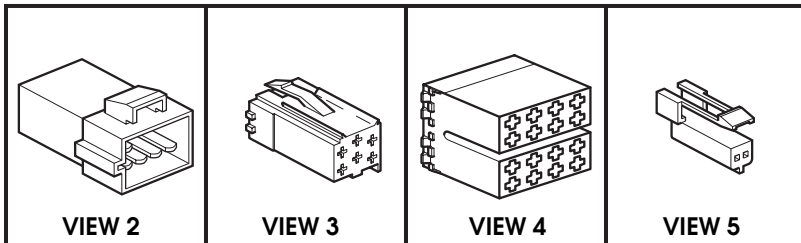
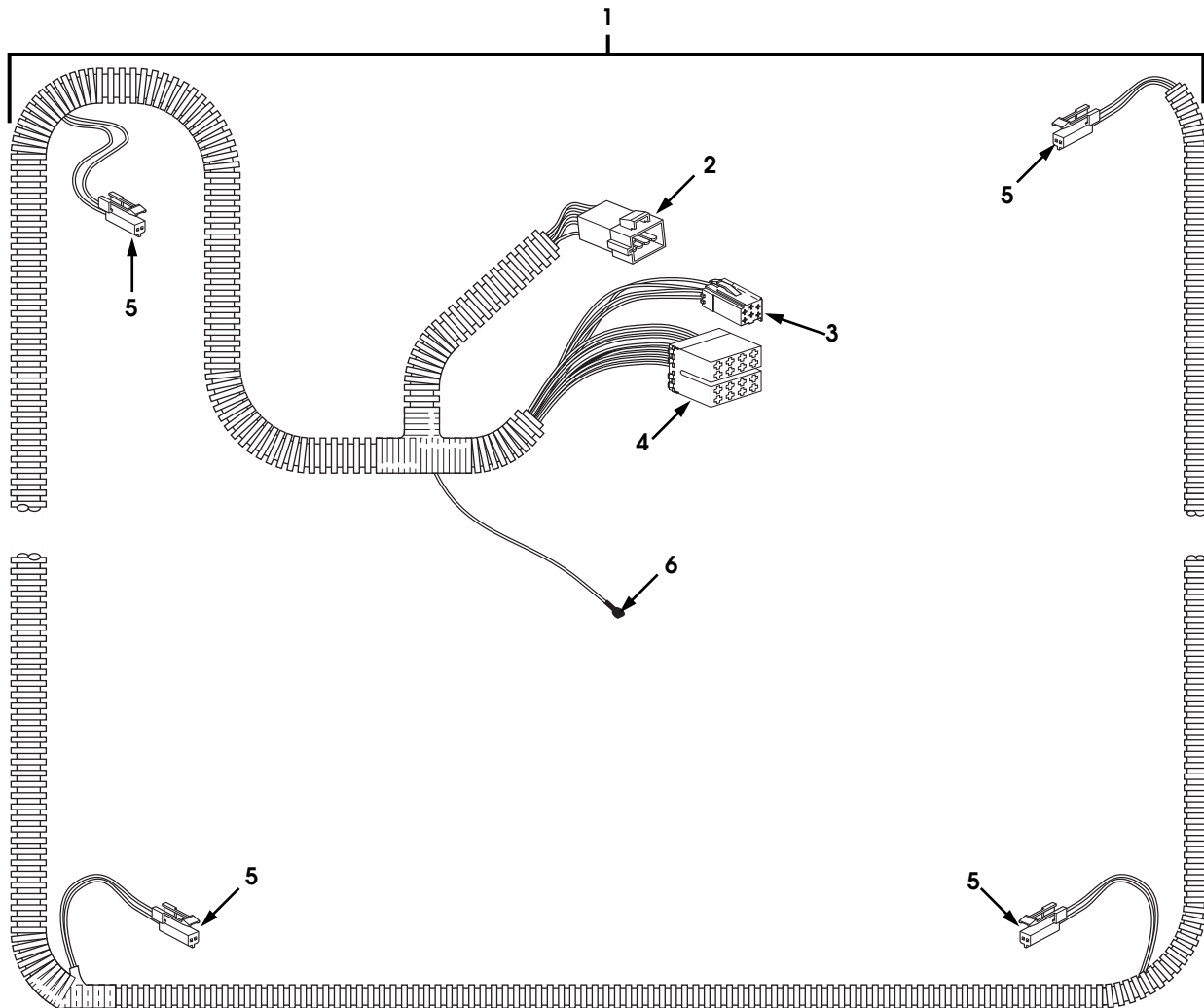

00-P12-007

Figure 12-23. Delco Standard Stereo Harness, Four-Speaker, Hard Top, Models 83 & 84.

# 2001 HUMMER PARTS CATALOG

**ELECTRICAL 12-63**

ITEM	PART NUMBER	DESCRIPTION	QTY
		<b>Figure 12-23. Delco Standard Stereo Harness, Four-Speaker, Hard Top, Models 83 &amp; 84.</b>	
1	6011013	HARNESS ASSEMBLY, Delco standard stereo, four-speaker ,hard top . . . . .	1
2	6008670	•CONNECTOR, 8-way, body harness . . . . .	1
3	N/S	•CONNECTOR, 6-way, radio . . . . .	1
4	N/S	•CONNECTOR, 16-way, radio . . . . .	1
5	6009363	•CONNECTOR, 2-way, speaker . . . . .	4
6	S.I.A.	•CELL PHONE MUTE. . . . .	1

# 2001 HUMMER PARTS CATALOG

## 12-64 ELECTRICAL

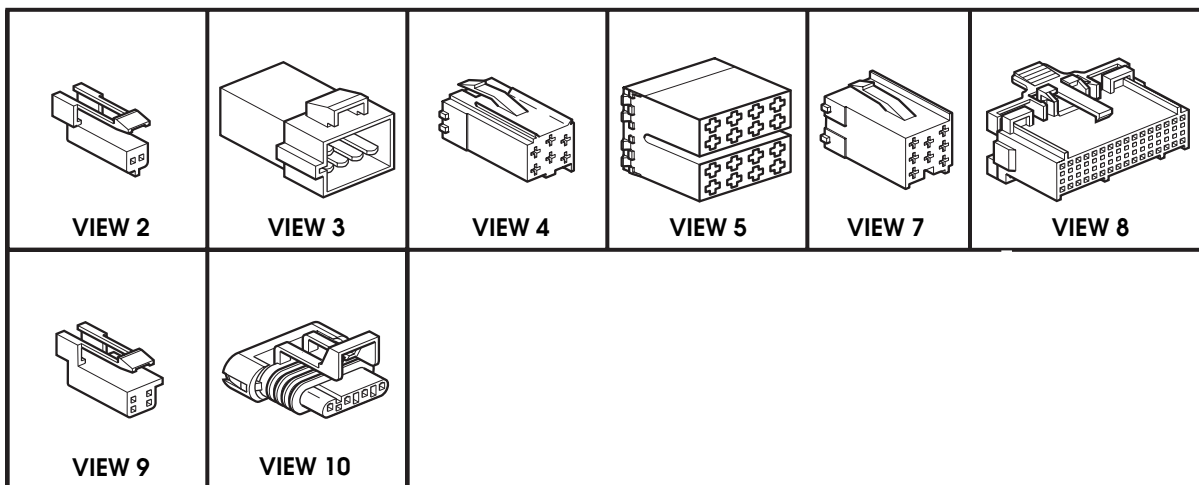
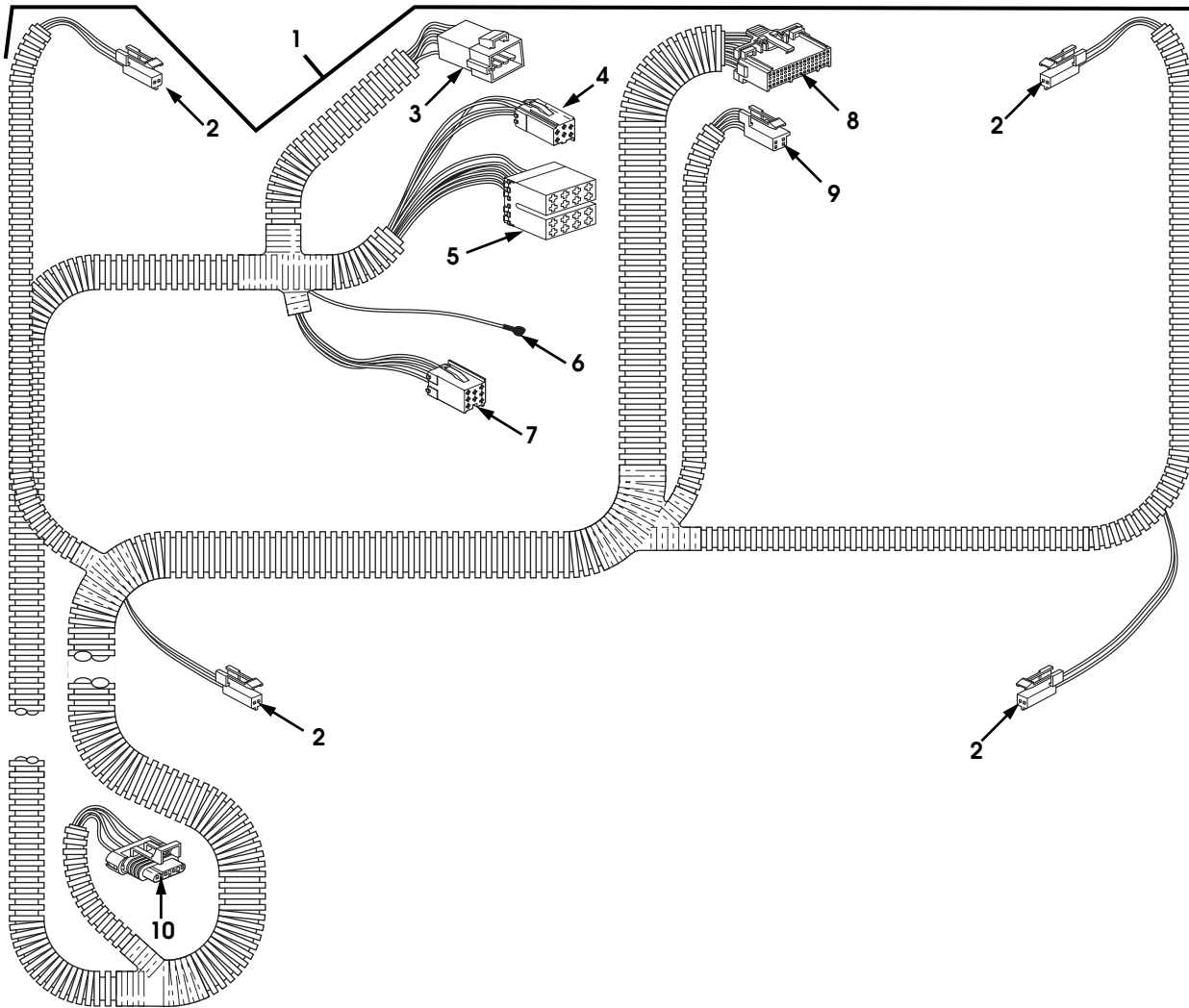

00-P12-005

Figure 12-24. Delco Monsoon Stereo System Harness, Hard Top, Models 83 & 84

# 2001 HUMMER PARTS CATALOG

## ELECTRICAL 12-65

ITEM	PART NUMBER	DESCRIPTION	QTY
		<b>Figure 12-24. Delco Monsoon Stereo System Harness, Hard Top, Models 83 &amp; 84</b>	
1	6011015	HARNES ASSEMBLY, Delco Monsoon stereo . . . . .	1
2	6009363	•CONNECTOR, speaker . . . . .	4
3	6008670	•CONNECTOR, 8-way, body harness . . . . .	1
4	N/S	•CONNECTOR, 6-way, radio . . . . .	1
5	N/S	•CONNECTOR, 16-way, radio . . . . .	1
6	S.I.A.	•CELL PHONE MUTE. . . . .	1
7	N/S	•CONNECTOR, 16-way, rear seat audio . . . . .	1
8	6004450	•CONNECTOR, 32-way, amplifier . . . . .	1
9	5939598	•CONNECTOR, 4-way, center-mount speakers. . . . .	1
10	6009362	•CONNECTOR, 4-way, subwoofer . . . . .	1

# 2001 HUMMER PARTS CATALOG

## 12-66 ELECTRICAL

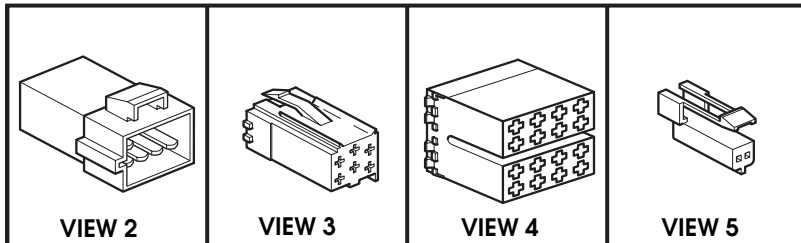
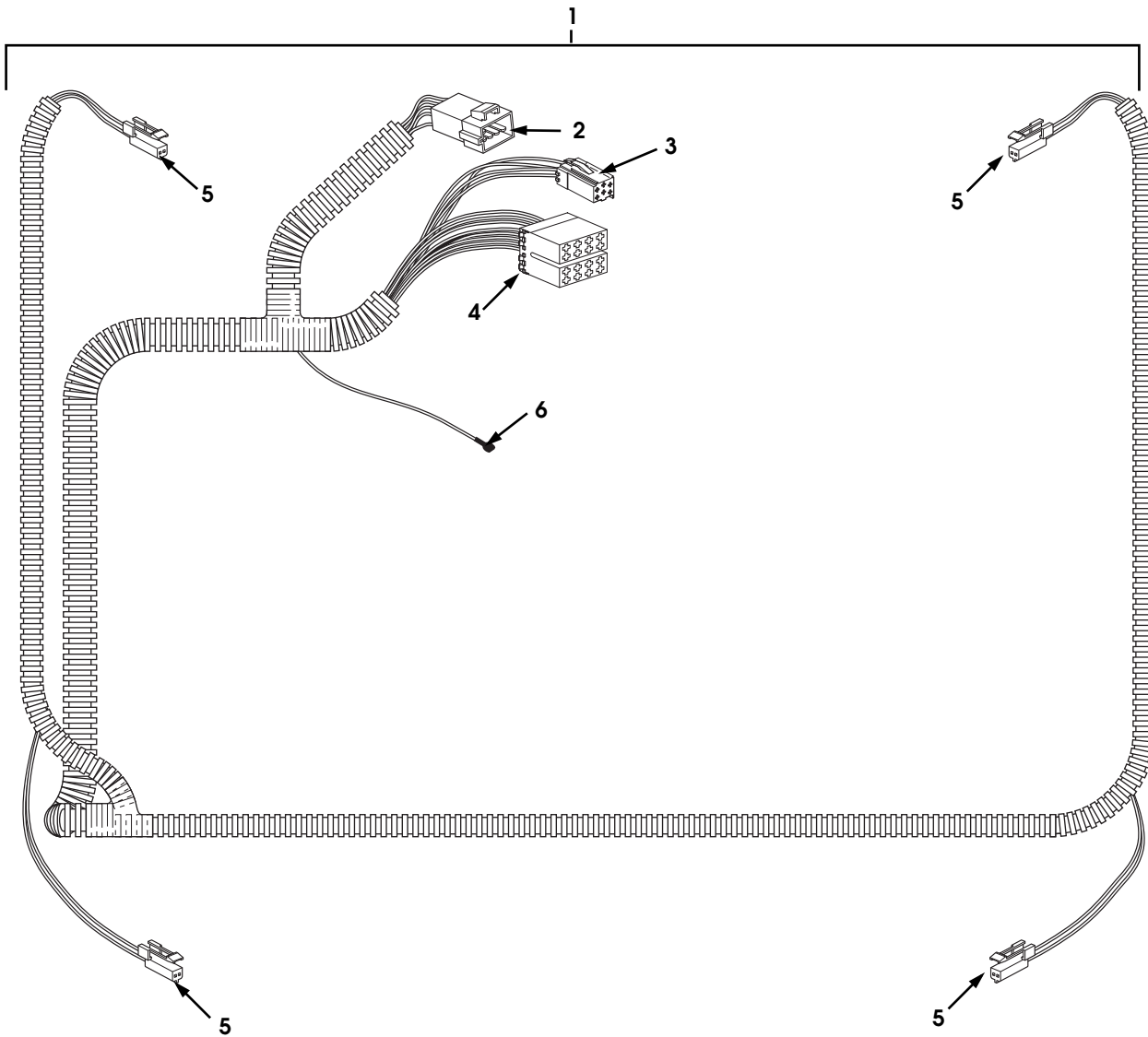

7-P12-003.1

Figure 12-25. Delco Standard Stereo Harness, Four-Speaker, Open Top, Model 90.

# 2001 HUMMER PARTS CATALOG

**ELECTRICAL 12-67**

ITEM	PART NUMBER	DESCRIPTION	QTY
		<b>Figure 12-25. Delco Standard Stereo Harness, Four-Speaker, Open Top, Model 90.</b>	
1	6011014	HARNESS ASSEMBLY, Delco standard stereo four-speaker, open top . . . . .	1
2	6008670	•CONNECTOR, 8-way, body harness . . . . .	1
3	S.I.A.	•CONNECTOR, 6-way, radio . . . . .	1
4	S.I.A.	•CONNECTOR, 16-way, radio . . . . .	1
5	5744900	•CONNECTOR, 2-way, speaker . . . . .	4
6	S.I.A.	•CELL PHONE MUTE. . . . .	1



# 2001 HUMMER PARTS CATALOG

## 12-68 ELECTRICAL

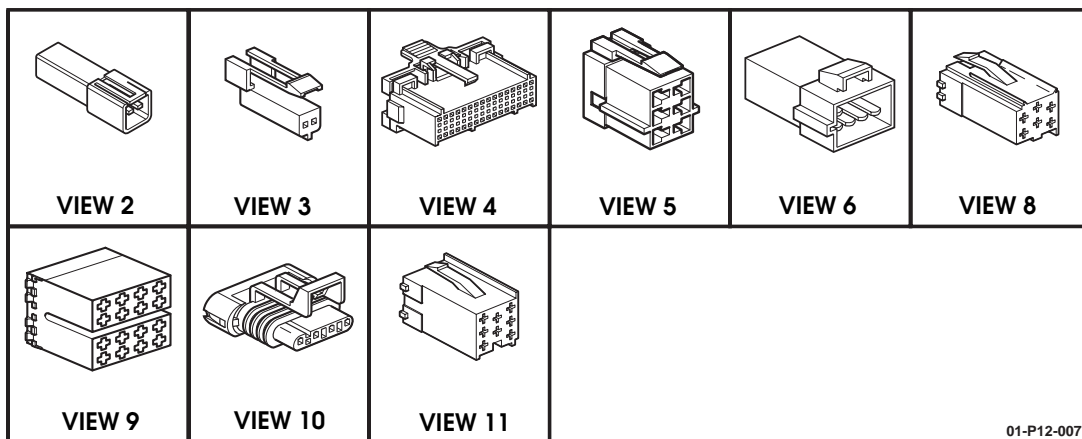
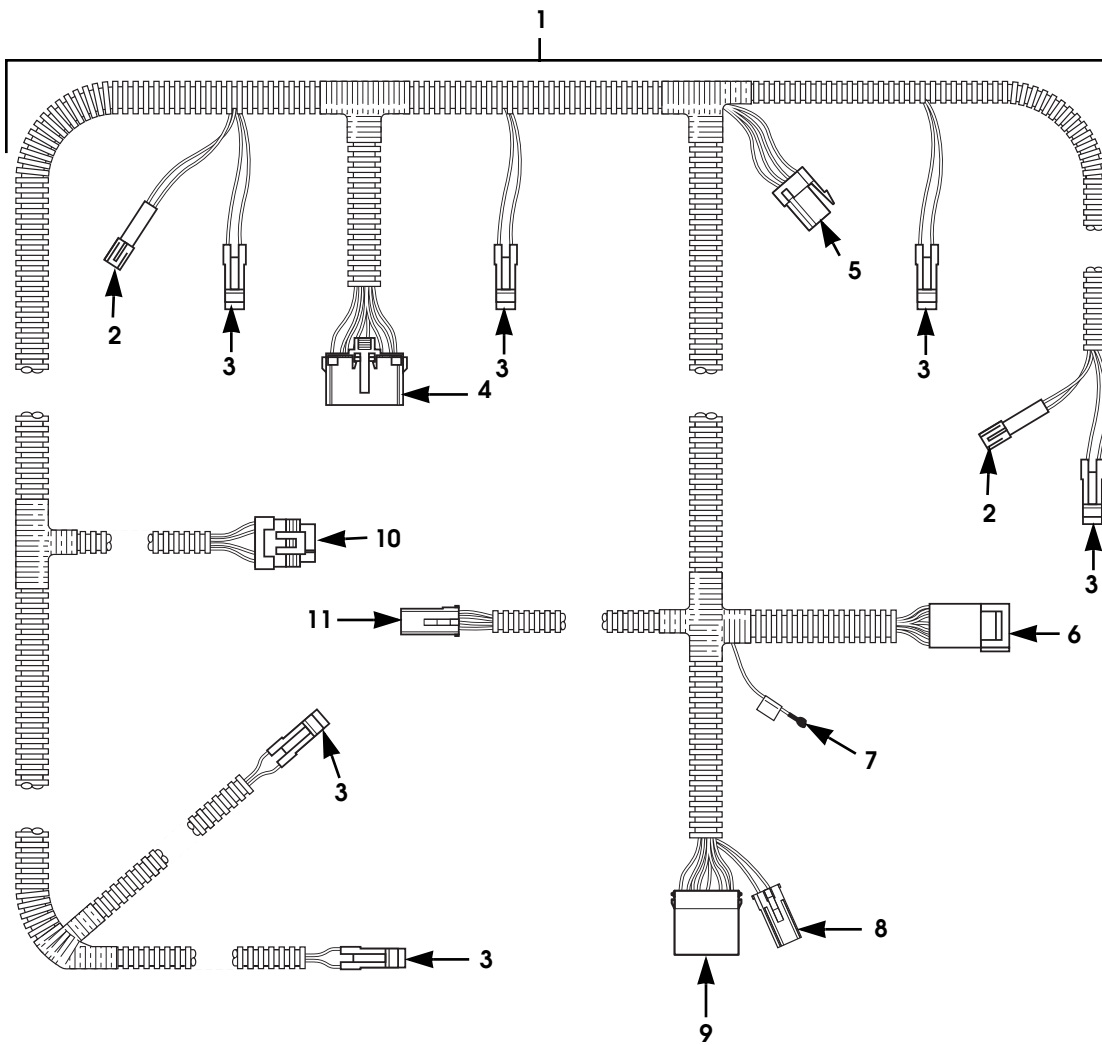

01-P12-007

Figure 12-26. Harness Assembly, Monsoon, Soft-Top.

# 2001 HUMMER PARTS CATALOG

## ELECTRICAL 12-69

ITEM	PART NUMBER	DESCRIPTION	QTY
		<b>Figure 12-26.</b> <b>Harness Assembly, Monsoon, Soft-Top.</b>	
1	6011670	HARNESS ASSEMBLY, soft-top Monsoon . . . . .	1
2	6003816	•CONNECTOR, 2-way, vanity mirror. . . . .	2
3	6009363	•CONNECTOR, 2-way, speaker . . . . .	6
4	6004450	•CONNECTOR, 32-way, amplifier. . . . .	1
5	6007029	•CONNECTOR, 6-way, cross body harness. . . . .	1
6	6008670	•CONNECTOR, 8-way, cross body harness. . . . .	1
7	N/S	•HEAT SHRINK. . . . .	1
8	6011023	•CONNECTOR, 6-way, radio. . . . .	1
9	6011024	•CONNECTOR, 16-way . . . . .	1
10	6009362	•CONNECTOR, 4-way, sub-woofer. . . . .	1
11	6011042	•CONNECTOR, 16-way, rear seat audio . . . . .	1

# 2001 HUMMER PARTS CATALOG

## 12-70 ELECTRICAL

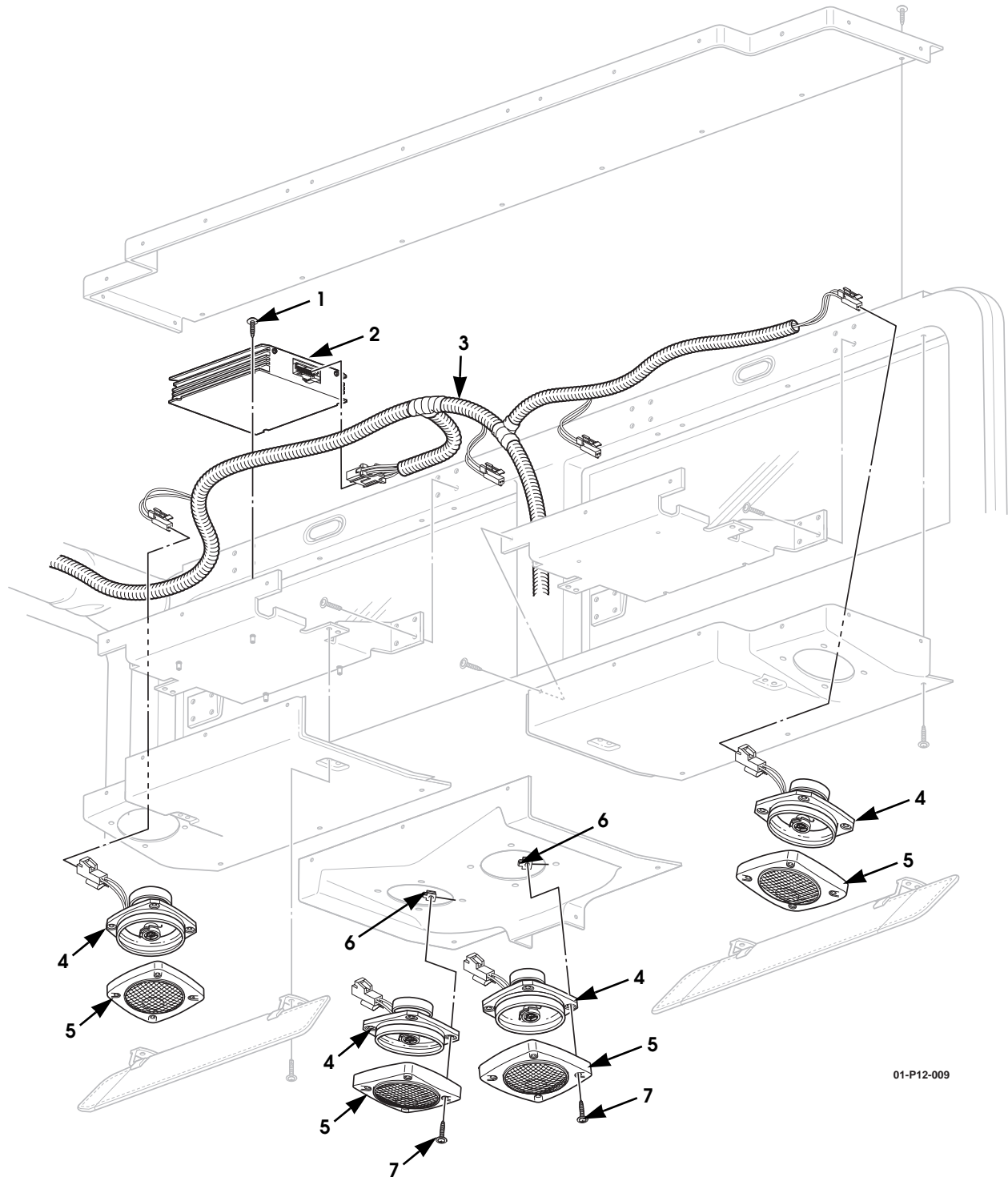

01-P12-009

Figure 12-27. Monsoon System, Soft-Top.

# 2001 HUMMER PARTS CATALOG

## ELECTRICAL 12-71

ITEM	PART NUMBER	DESCRIPTION	QTY
		<b>Figure 12-27. Monsoon System, Soft-Top.</b>	
1	N/S	SCREW, hhms, #10 - 24 x 3/4 . . . . .	4
2	6010850	AMPLIFIER, Monsoon . . . . .	1
3	6011670	HARNESS, Monsoon, soft-top . . . . .	1
4	6009152	SPEAKER . . . . .	4
5	6009154	COVER, speaker . . . . .	4
6	12341352	SPEED NUT . . . . .	16
7	159701P2	SCREW, phcr . . . . .	16

# 2001 HUMMER PARTS CATALOG

## 12-72 ELECTRICAL

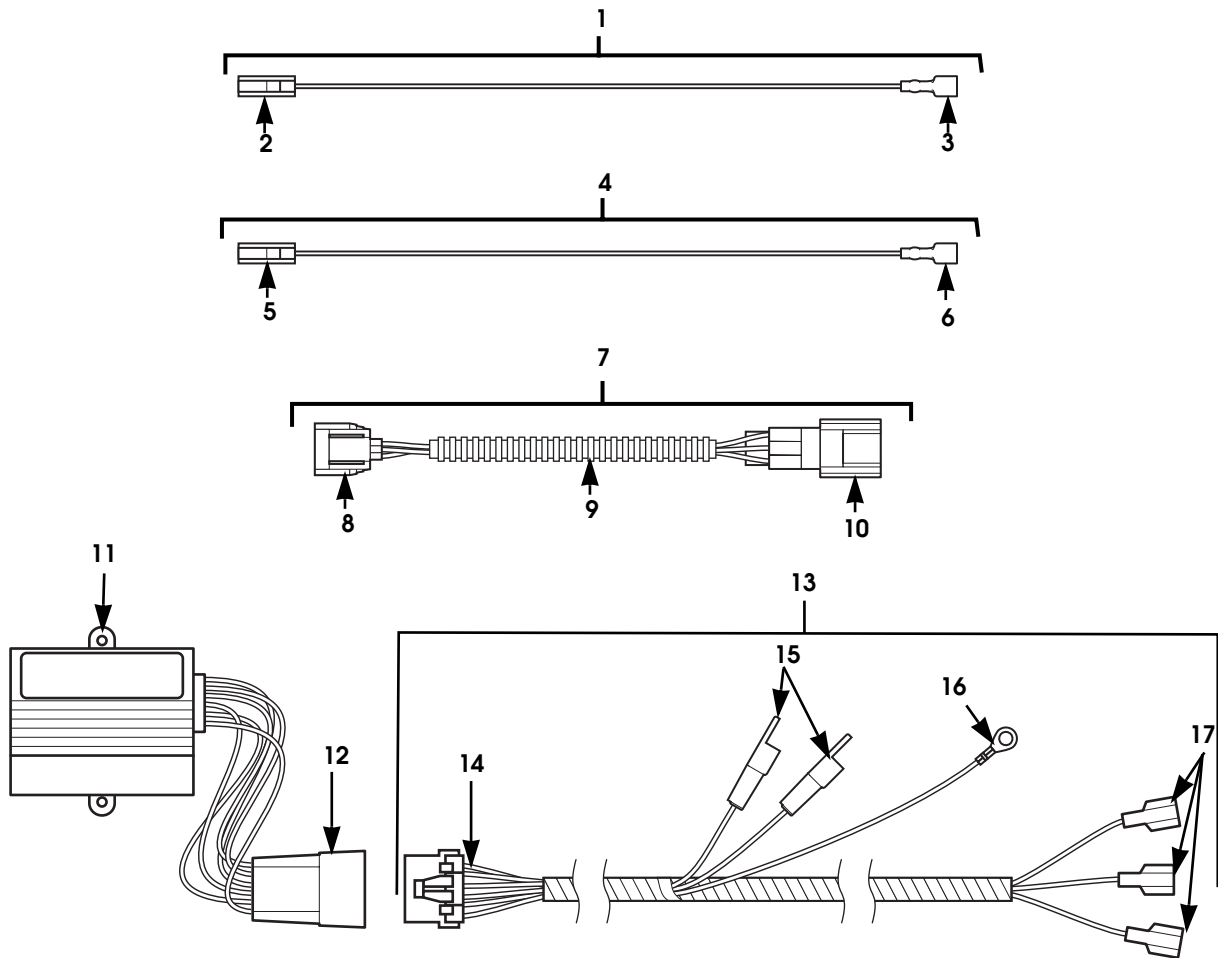

VIEW 2	VIEW 3	VIEW 5	VIEW 6	VIEW 8	VIEW 10
VIEW 12	VIEW 14	VIEW 15	VIEW 16	VIEW 17	

00-P12-009

Figure 12-28. Daytime Running Light Jumper and Harness.

# 2001 HUMMER PARTS CATALOG

## ELECTRICAL 12-73

ITEM	PART NUMBER	DESCRIPTION	QTY
		<b>Figure 12-28. Daytime Running Light Jumper and Harness.</b>	
1	6010839	JUMPER ASSEMBLY, daytime running light, (Canada only), yellow . . . . .	1
2	5903092	•INSULATOR, connector . . . . .	1
3	S.I.A.	•CONNECTOR . . . . .	1
4	6010837	JUMPER ASSEMBLY, ignition, DLR & GCC, white . . . . .	1
5	5903092	•INSULATOR, connector . . . . .	1
6	S.I.A.	•CONNECTOR . . . . .	1
7	6010841	JUMPER ASSEMBLY, brake fluid level, DRL . . . . .	1
8	S.I.A.	•CONNECTOR, 3-way, to master cylinder. . . . .	1
9	S.I.A.	•DIODE (in heat-shrinking tubing). . . . .	1
10	S.I.A.	•CONNECTOR, 3-way . . . . .	1
11	6002625	MODULE ASSEMBLY, daytime running light . . . . .	1
12	S.I.A.	•CONNECTOR . . . . .	1
13	6002626	HARNESS, module, daytime running light (Canada only) . . . . .	1
14	6002769	•CONNECTOR, 8-way . . . . .	1
15	6002767	•CONNECTOR . . . . .	2
16	S.I.A.	•TERMINAL RING . . . . .	1
17	6002829	•CONNECTOR . . . . .	3

# 2001 HUMMER PARTS CATALOG

## 12-74 ELECTRICAL

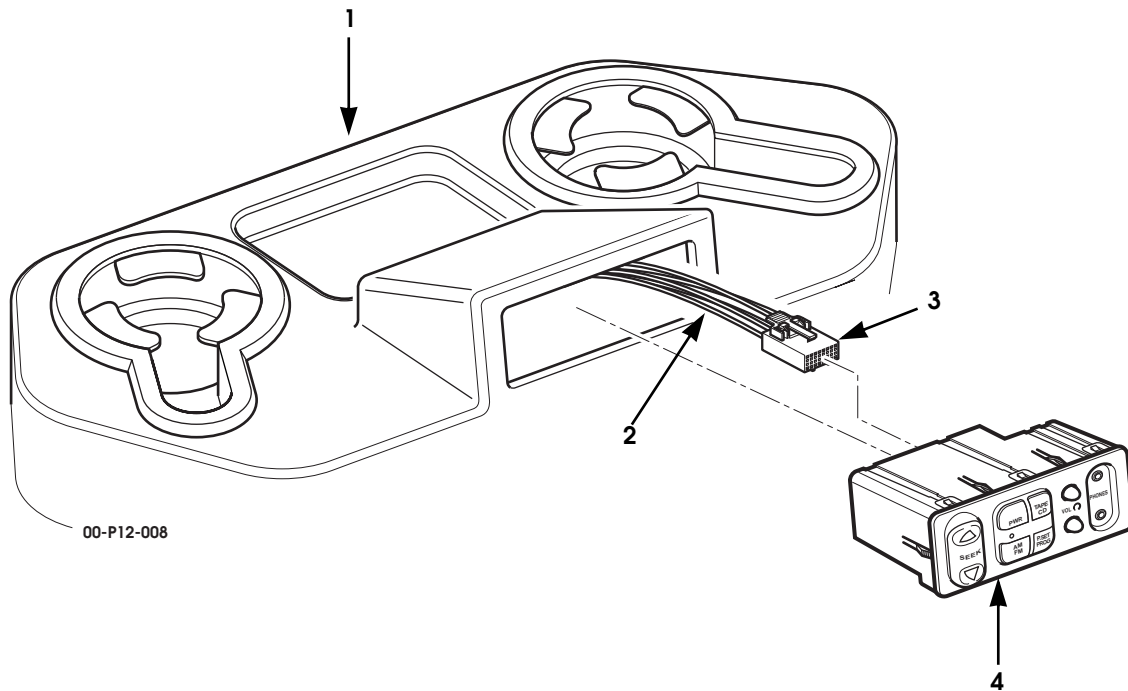

Figure 12-29. Rear Seat Audio

# 2001 HUMMER PARTS CATALOG

## ELECTRICAL 12-75

ITEM	PART NUMBER	DESCRIPTION	QTY
		<b>Figure 12-29. Rear Seat Audio</b>	
1	6011049G	REAR CONSOLE ASSEMBLY, gray .....	1
1	6011049	REAR CONSOLE ASSEMBLY, tan .....	1
2	6011015	MONSOON RADIO HARNESS .....	1
3	N/S	CONNECTOR, 16-way .....	1
4	6011039	REAR SEAT AUDIO MODULE .....	1



# 2001 HUMMER PARTS CATALOG

## 12-76 ELECTRICAL

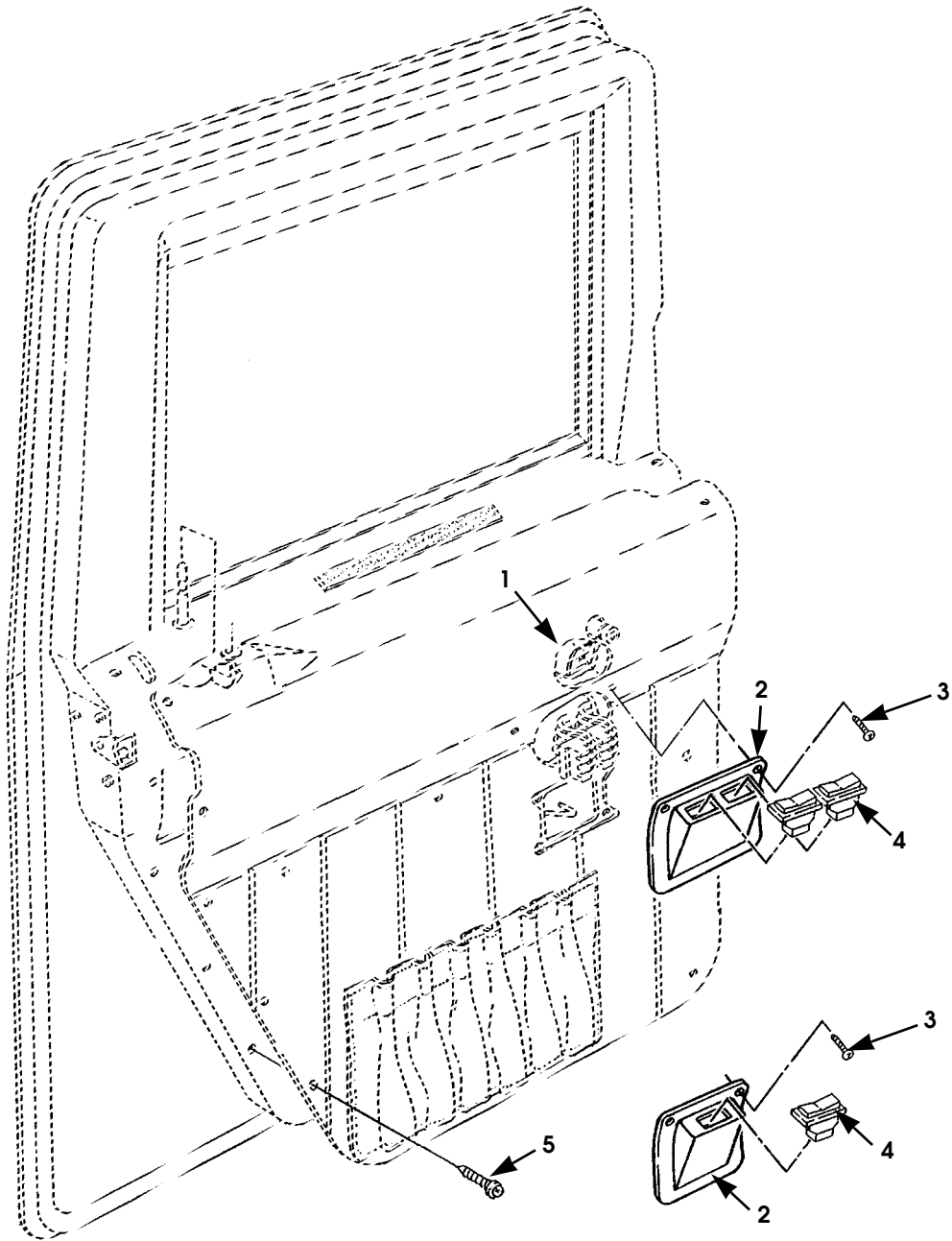

P12-052.1

*Figure 12-30. Power Door Locks  
(Sheet 1 of 6).*

# 2001 HUMMER PARTS CATALOG

ELECTRICAL 12-77

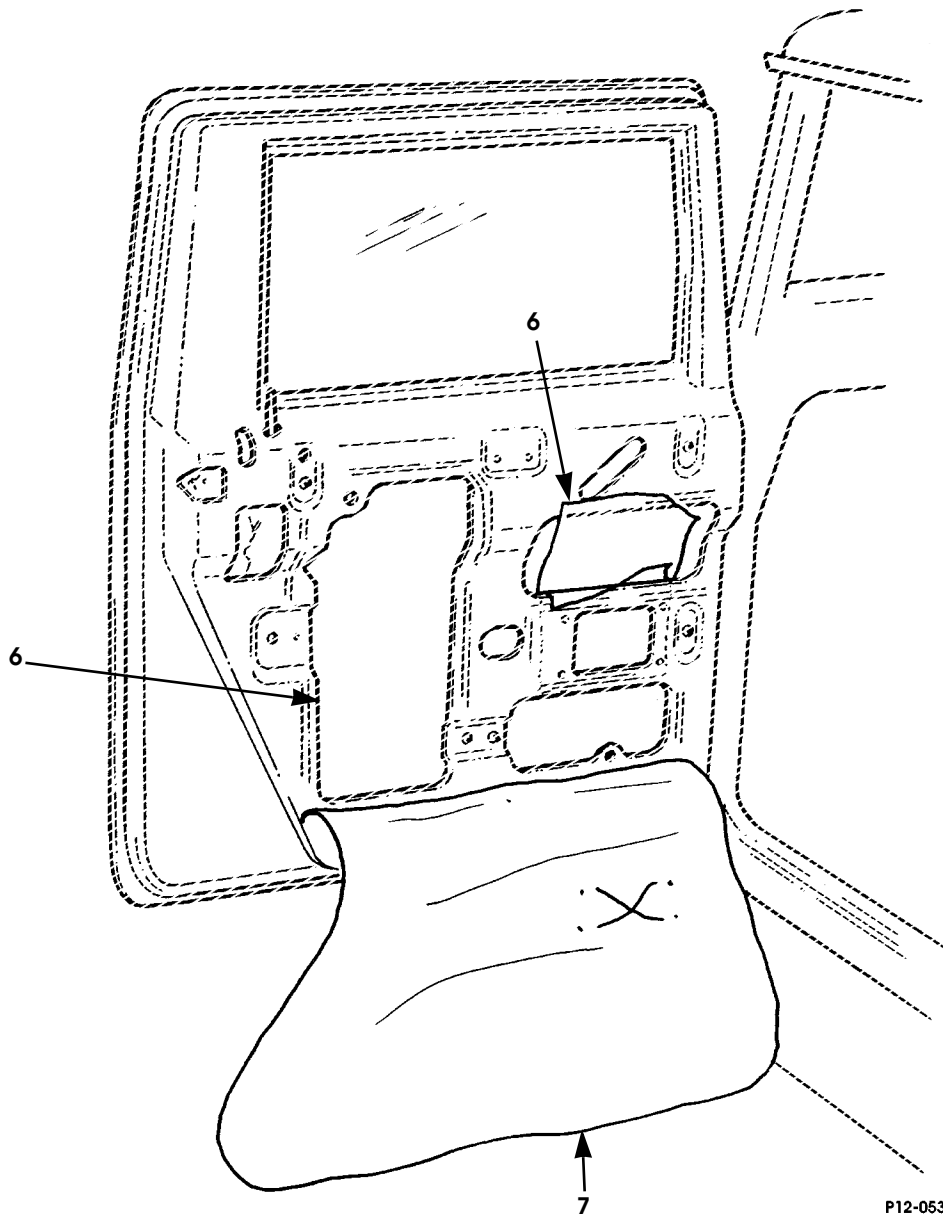

P12-053

Figure 12-30. Power Door Locks  
(Sheet 2 of 6).

AM General Corporation

# 2001 HUMMER PARTS CATALOG

## 12-78 ELECTRICAL

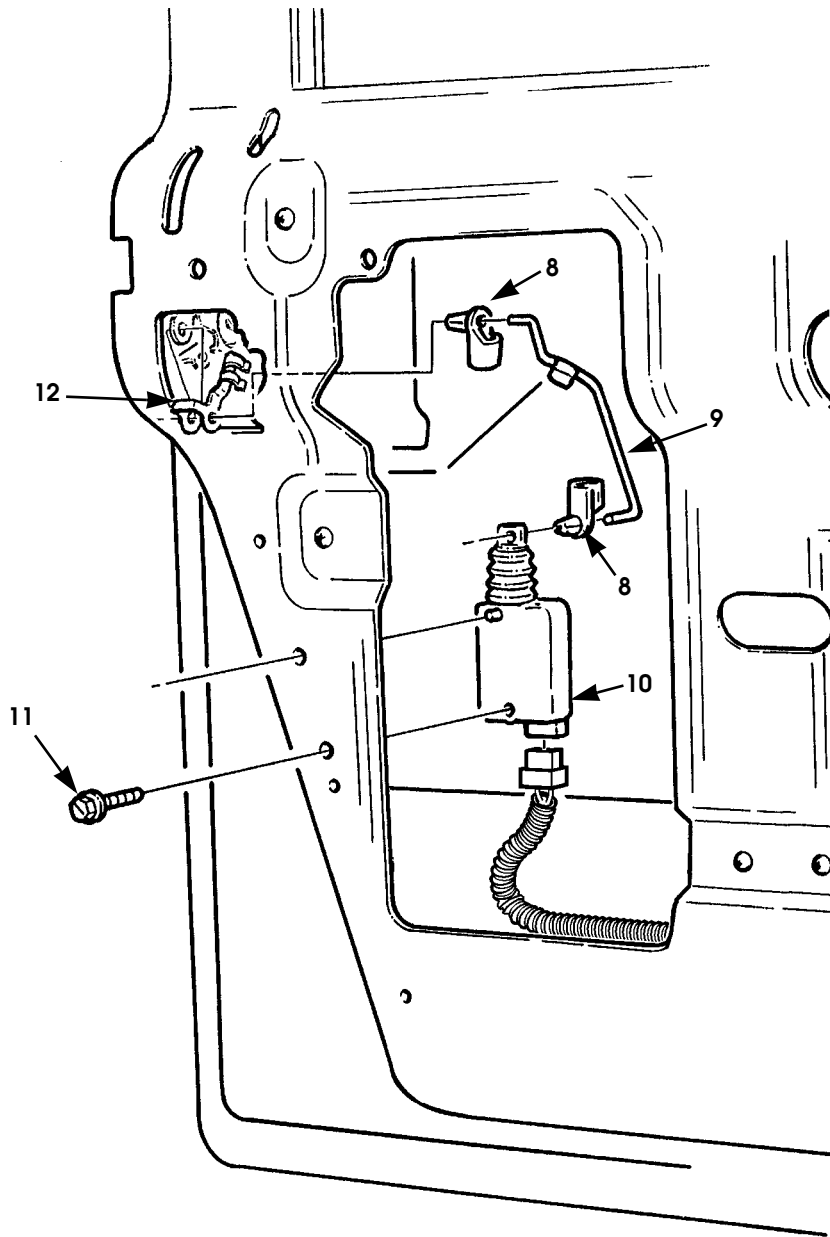

P12-055.1

Figure 12-30. Power Door Locks  
(Sheet 3 of 6).

REAR DOOR

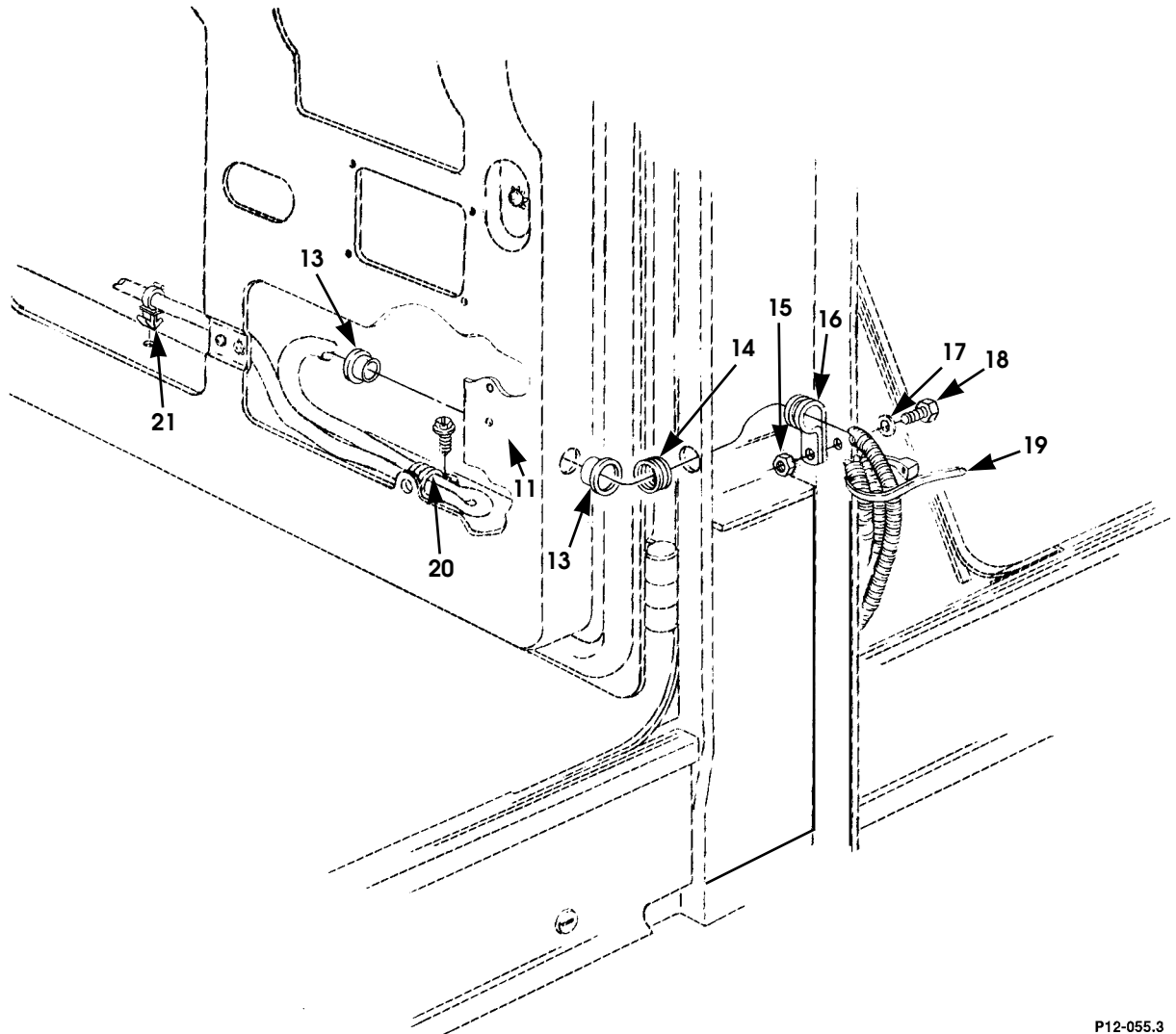

P12-055.3

Figure 12-30. Power Door Locks  
(Sheet 4 of 6).

# 2001 HUMMER PARTS CATALOG

## 12-80 ELECTRICAL

### FRONT DOOR

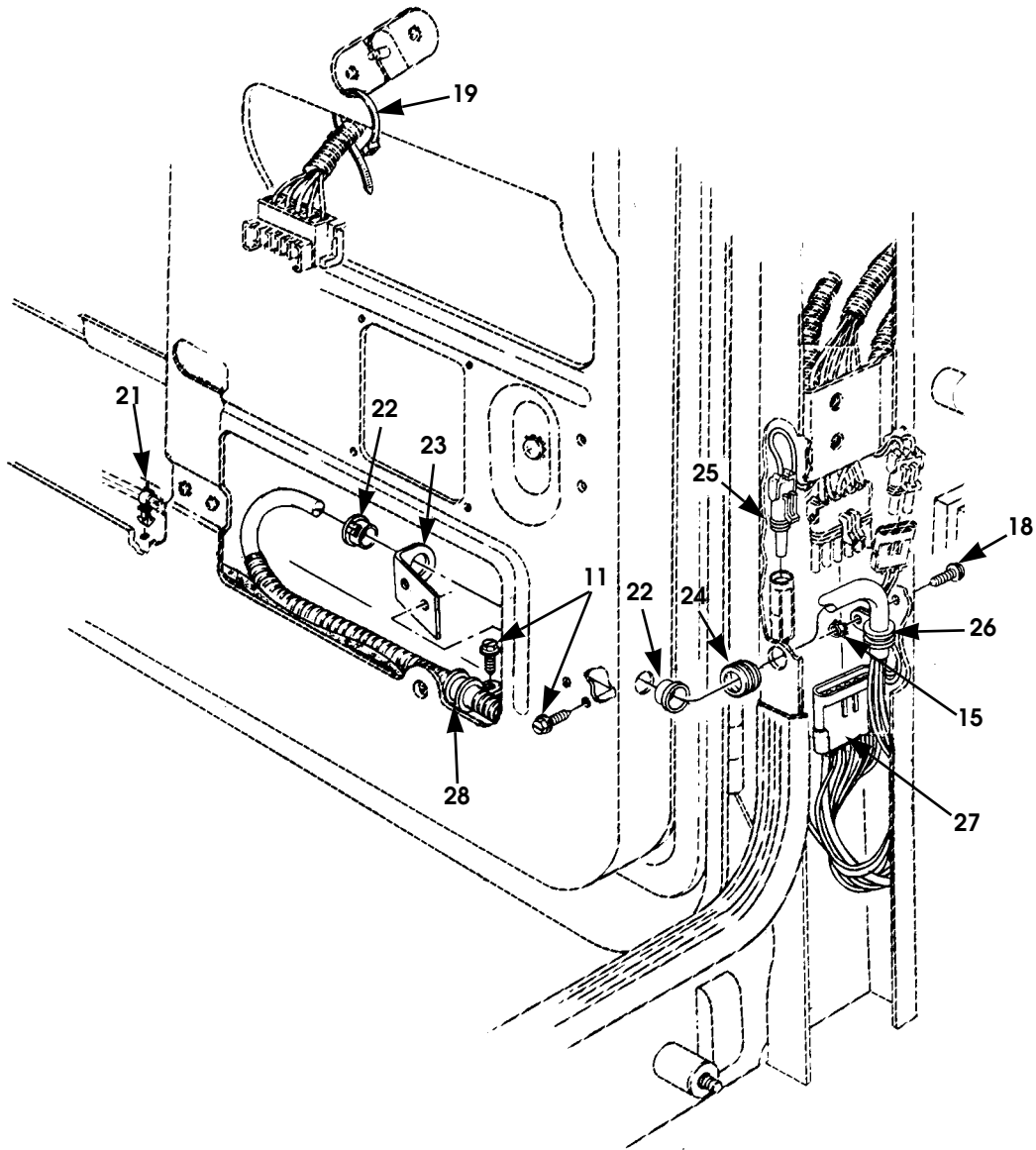

P12-056.2

Figure 12-30. Power Door Locks  
(Sheet 5 of 6).

# 2001 HUMMER PARTS CATALOG

ELECTRICAL 12-81

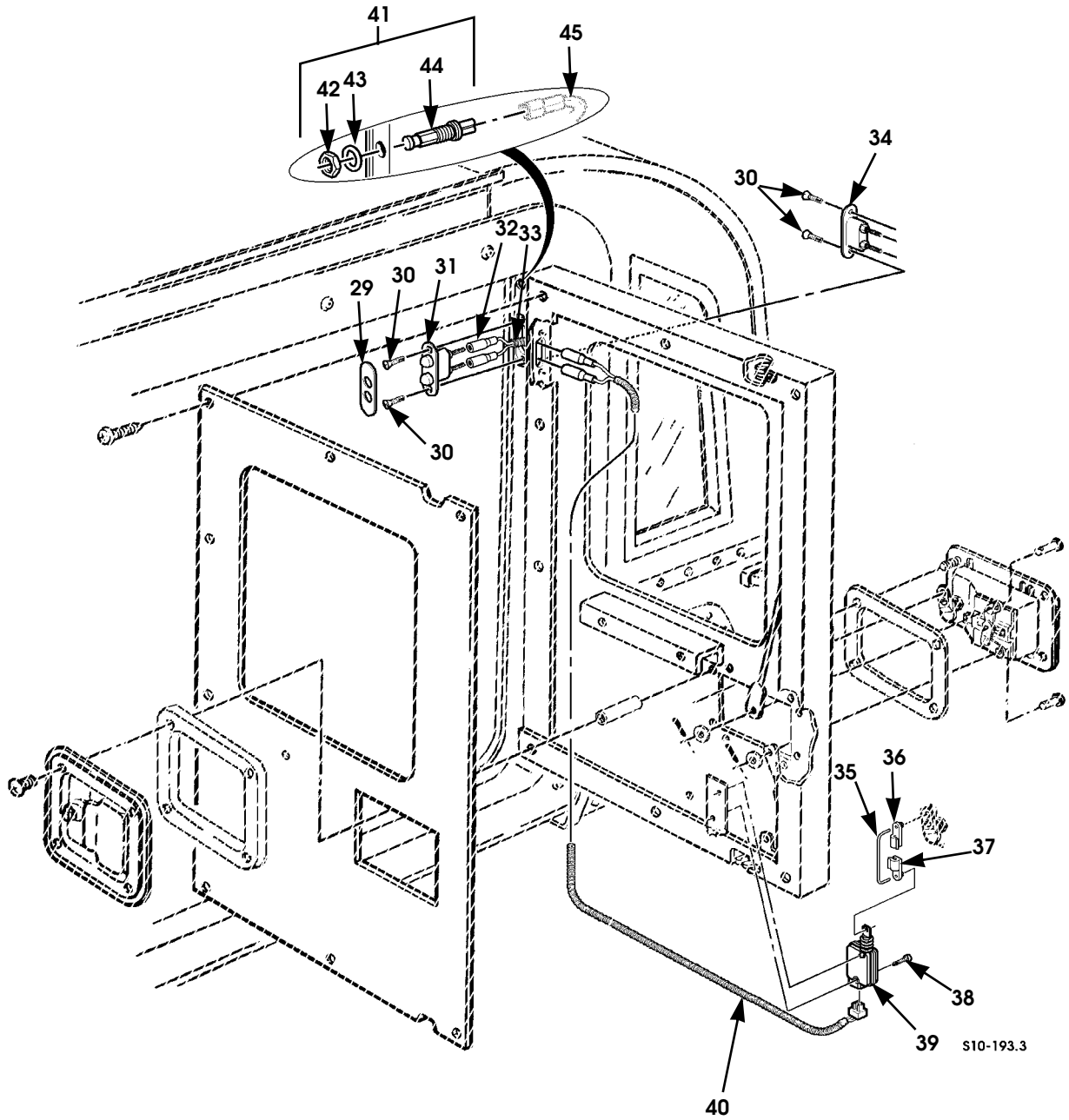

Figure 12-30. Power Door Locks  
(Sheet 6 of 6).

AM General Corporation

# 2001 HUMMER PARTS CATALOG

## 12-82 ELECTRICAL

ITEM	PART NUMBER	DESCRIPTION	QTY	
			2-Dr	4-Dr
		<b>Figure 12-30. Power Door Locks.</b>		
1	6003025	NUT, flat type. . . . .	4	4
2	6003023	BEZEL, door switch (single) . . . . .	2	2
2	6003024	BEZEL, door switch (dual) . . . . .	2	2
3	N/S	SCREW, phcr, tapping, #8 - 18 x 1/2 . . . . .	4	4
4	6002016	SWITCH, door lock . . . . .	2	2
5	N/S	SCREW & WASHER ASSEMBLY, trim, #8 - 18 x 1 . . . . .	2	2
6	6001694	WATERSHIELD, door latch . . . . .	2	4
7	6001623	WATERSHIELD, front, L.H. . . . .	1	1
7	6001624	WATERSHIELD, front, R.H. . . . .	1	1
7	6001625	WATERSHIELD, rear, L.H. . . . .		1
		83, 84, 90		
7	6001626	WATERSHIELD, rear, R.H. . . . .		1
		83, 84, 90		
8	5939037	CLIP, rod end. . . . .	4	8
9	6001831	ACTUATOR ROD, front, L.H. . . . .	1	1
9	6001832	ACTUATOR ROD, front, R.H. . . . .	1	1
9	6001833	ACTUATOR ROD, rear, L.H. . . . .		1
		83, 84, 90		
9	6001834	ACTUATOR ROD, rear, R.H. . . . .		1
		83, 84, 90		
10	6003590	ACTUATOR, power door lock, w/o pigtail . . . . .	2	4
11	N/S	SCREW, truss head, tapping, #8 - 18 x 5/8 . . . . .	8	16
12	6011276	ROD, door latch . . . . .	1	2
13	6001892	BUSHING, snap . . . . .		4
		83, 84, 90		
14	6002437	GROMMET, rubber, B-pillar. . . . .		2
		83, 84, 90		
15	N/S	LOCKNUT, nylon insert, #10 - 32. . . . .	2	4
16	N/S	CLAMP, cushioned 5/16" . . . . .		2
		83, 84, 90		
17	N/S	WASHER, flat, #10 . . . . .		2
18	N/S	SCREW, #10 - 32 x 3/4, ZN . . . . .	2	4
19	MS3367-1	TIEDOWN STRAP . . . . .	3	7
20	N/S	CLAMP, cushioned, 5/8" . . . . .		2
21	6002466	RETAINER, wire . . . . .	2	4
22	6001893	BUSHING, snap . . . . .	4	8

# 2001 HUMMER PARTS CATALOG

## ELECTRICAL 12-83

ITEM	PART NUMBER	DESCRIPTION	QTY	
			2-Dr	4-Dr
		<b>Figure 12-30. Power Door Locks (Cont'd.)</b>		
23	6001840	BRACKET, front, L.H. ....	1	1
23	6001841	BRACKET, front, R.H. ....	1	1
23	6001842	BRACKET rear L/H ....		1
23	6001843	BRACKET rear R/H ....		1
24	MS35489-16	GROMMET, rubber, A-pillar ....	2	2
25	N/S	PLUG, connector, male ....	2	2
26	N/S	CLAMP, cushioned, 7/16" ....	2	2
27	5995713	CONNECTOR, 6-way ....	2	2
28	N/S	CLAMP, cushioned, 11/16" ....	2	2
29	6008581	SEAL, door lock switch ....		1
30	N/S	SCREW, flat head, #6 - 32 x 5/8 ....		4
31	6008348	CONTACTS, power door lock, jamb-side ....		1
32	6009730	CONNECTOR, plug ....		2
33	6010117	HARNESS, jumper, rear door, R.H., S/W ....		1
34	6008347	CONTACTS, power door lock, door-side ....		1
35	6008346	ROD, power lock ....		1
36	6000747	ROD CLIP, interior handle rod ....		5
37	5939037	ROD END CLIP ....		1
38	6006283	SCREW, truss head ....		1
39	6003590	ACTUATOR, power door lock ....		1
40	6008553	HARNESS, power door lock, cargo door ....		1
41	5939088	SWITCH ASSEMBLY, door jamb ....		1
42	S.I.A.	•NUT ....		1
43	S.I.A.	•WASHER ....		1
44	S.I.A.	•SWITCH, door jamb ....		1
45	6010032	WIRING HARNESS, 4-door ....		1
	5939088	SWITCH, door jamb (not illustrated) ....		5
		84, 91		



# 2001 HUMMER PARTS CATALOG

## 12-84 ELECTRICAL

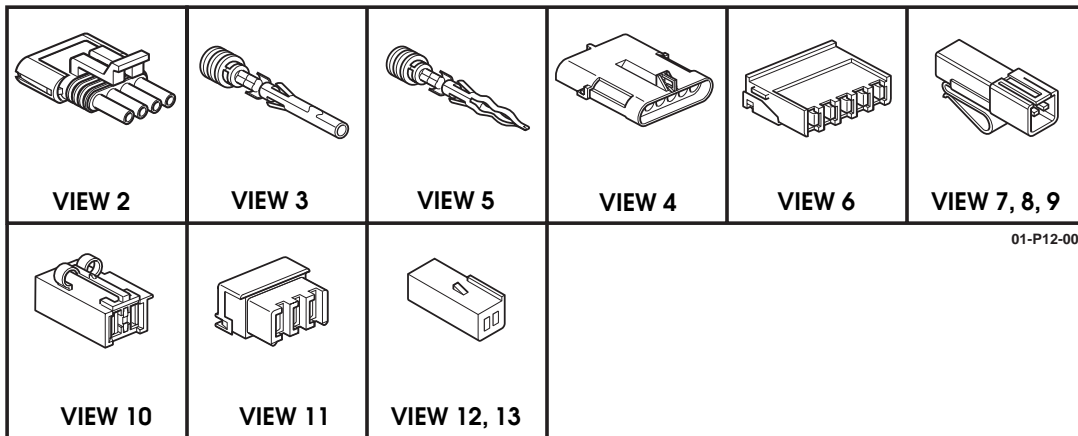
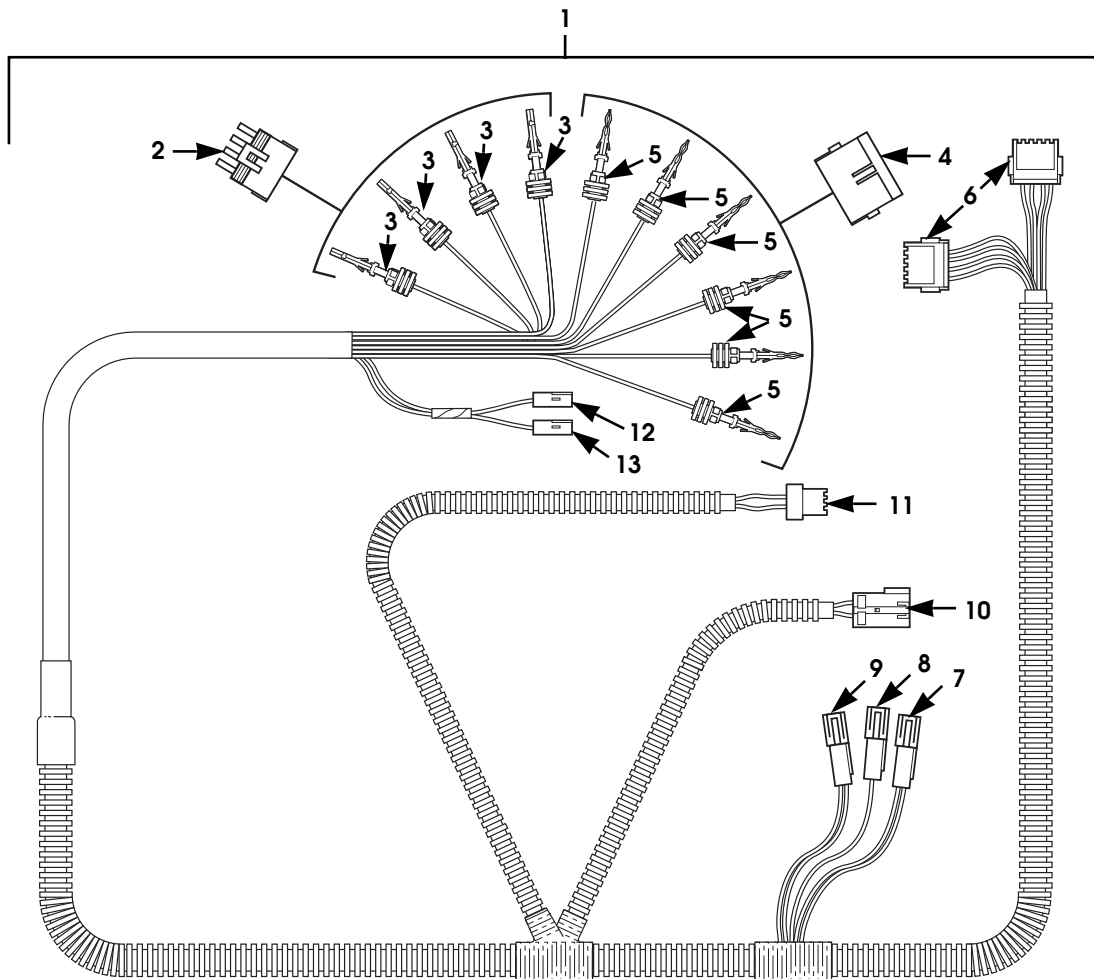

01-P12-006

Figure 12-31. Door Harness Assembly, Front.

# 2001 HUMMER PARTS CATALOG

## ELECTRICAL 12-85

ITEM	PART NUMBER	DESCRIPTION	QTY
		<b>Figure 12-31. Door Harness Assembly, Front.</b>	
1	6010864	HARNESS ASSEMBLY, R.H. front door . . . . .	1
1	6010865	HARNESS ASSEMBLY, L.H. front door . . . . .	1
2	5995715	•CONNECTOR, 4-way, cross body, SEE NOTE 1 . . . . .	1
3	6003941	••TERMINAL . . . . .	4
4	5995713	•CONNECTOR, 6-way, cross body, SEE NOTE 2 . . . . .	1
5	6003942	••TERMINAL . . . . .	6
6	6002930	•CONNECTOR, 5-way . . . . .	2
7	6000135	•CONNECTOR, 2-way, power mirror jumper harness . .	1
8	6010870	•CONNECTOR, 2-way, power mirror jumper harness . .	1
9	6003816	•CONNECTOR, 2-way, power mirror jumper harness . .	1
10	6002932	•CONNECTOR, 2-way, window regulator motor . . . . .	1
11	6003236	•CONNECTOR, 3-way, actuator. . . . .	1
12	6010415	•CONNECTOR, 4-way, mirror body harness . . . . .	1
13	6003815	•CONNECTOR, 2-way, mirror body harness . . . . .	1
		NOTE 1: THIS CONNECTOR DOES NOT COME WITH THE DOOR HARNESS. THE DOOR HARNESS ENDS WITH FOUR TERMINALS TO FIT THROUGH HOLES IN THE DOOR AND THEN INTO THIS CONNECTOR.	
		NOTE 2: THIS CONNECTOR DOES NOT COME WITH THE DOOR HARNESS. THE DOOR HARNESS ENDS WITH SIX TERMINALS TO FIT THROUGH HOLES IN THE DOOR AND THEN INTO THIS CONNECTOR.	

# 2001 HUMMER PARTS CATALOG

## 12-86 ELECTRICAL

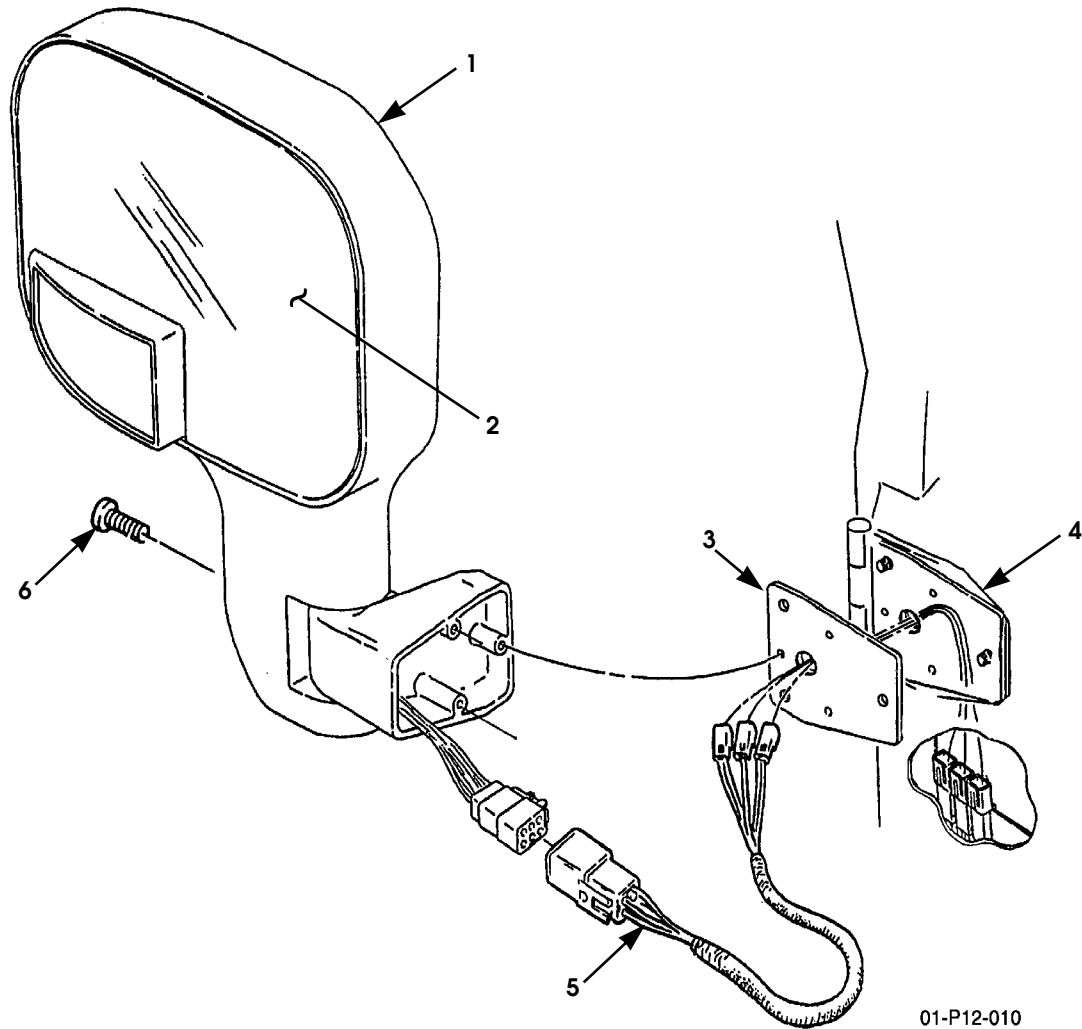

Figure 12-32. Heated Power Exterior Mirrors.

# 2001 HUMMER PARTS CATALOG

## ELECTRICAL 12-87

ITEM	PART NUMBER	DESCRIPTION	QTY
		<b>Figure 12-32. Heated Power Exterior Mirrors.</b>	
1	6011580	MIRROR, heated power, exterior, L.H. . . . .	1
1	6011581	MIRROR, heated power, exterior, R.H. . . . .	1
2	5745421	•GLASS, replacement, exterior power mirror, L.H. . . . .	1
2	5745422	•GLASS, replacement, exterior power mirror, R.H. . . . .	1
3	6003449	GASKET, heated power mirror . . . . .	1
4	6003618	PLATE, mirror mounting . . . . .	1
5	6010863	JUMPER HARNESS ASSEMBLY, heated power mirrors . .	1
6	N/S	SCREW, flat head, 1/4 - 20 x 3/4, ZN . . . . .	6

# 2001 HUMMER PARTS CATALOG

## 12-88 ELECTRICAL

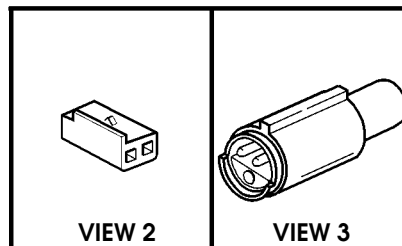
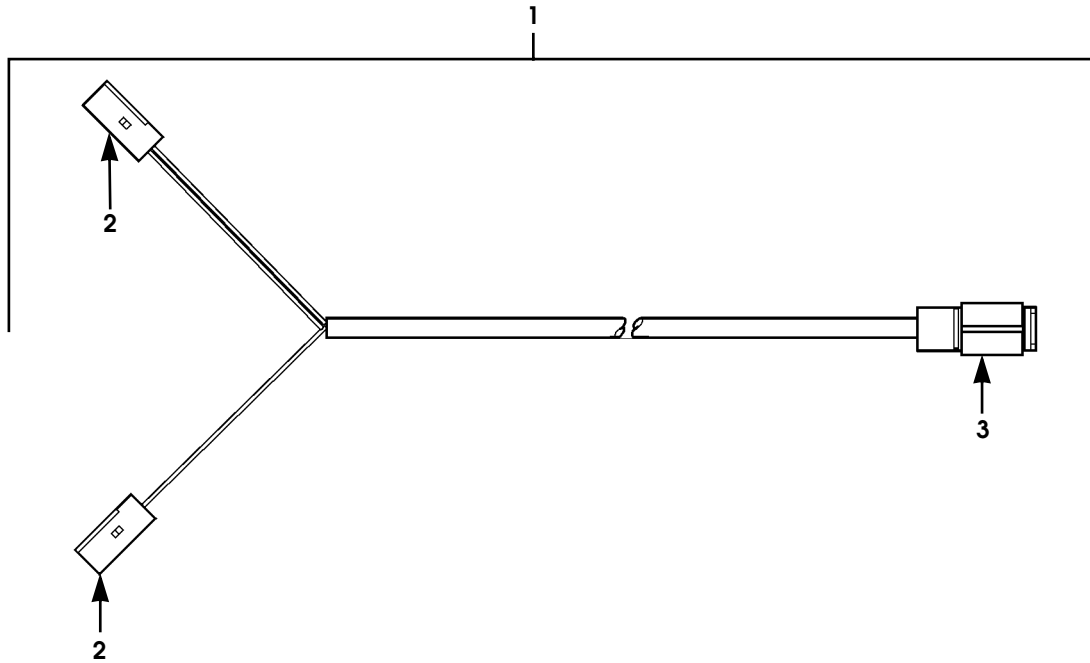

9-P12-014

Figure 12-33. Power Mirror Jumper Harness Assembly

# 2001 HUMMER PARTS CATALOG

**ELECTRICAL 12-89**

ITEM	PART NUMBER	DESCRIPTION	QTY
		<b>Figure 12-33. Power Mirror Jumper Harness Assembly</b>	
1	6010863	JUMPER HARNESS ASSEMBLY, power mirror . . . . .	2
2	S.I.A.	•CONNECTOR, body harness . . . . .	2
3	S.I.A.	•CONNECTOR, power mirror . . . . .	1

# 2001 HUMMER PARTS CATALOG

## 12-90 ELECTRICAL

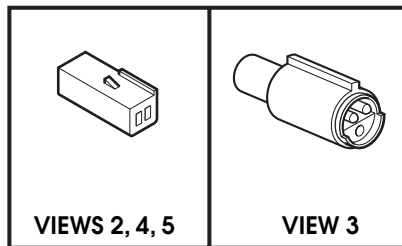
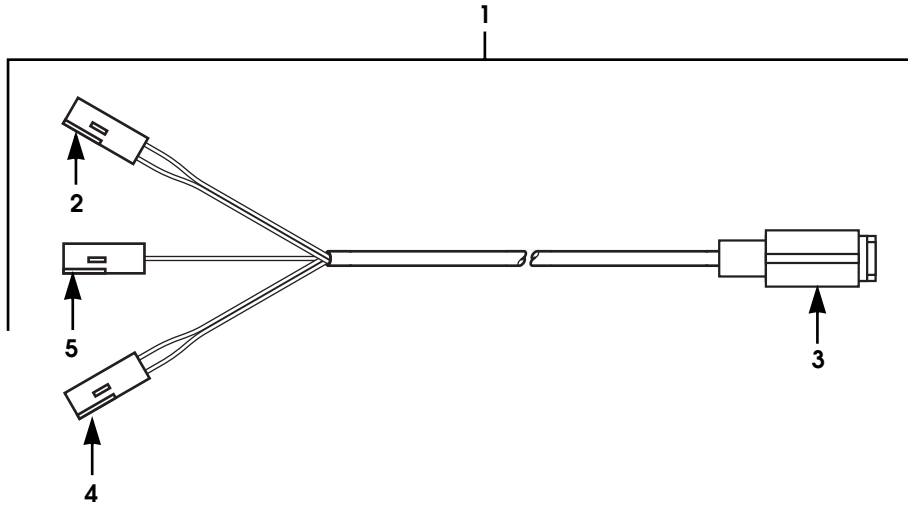

01-P12-005

Figure 12-34. Power Mirror Jumper Harness Assembly, Heated

# 2001 HUMMER PARTS CATALOG

**ELECTRICAL 12-91**

ITEM	PART NUMBER	DESCRIPTION	QTY
		<b>Figure 12-34. Power Mirror Jumper Harness Assembly, Heated</b>	
1	6010863	JUMPER HARNESS ASSEMBLY, heated power mirrors . .	1
2	6003815	•CONNECTOR, 2-way, door harness . . . . .	1
3	6011594	•CONNECTOR, 6-way, mirror harness . . . . .	1
4	6003071	•CONNECTOR, 2-way, door harness . . . . .	1
5	6010872	•CONNECTOR, 2-way, door harness . . . . .	1



# 2001 HUMMER PARTS CATALOG

## 12-92 ELECTRICAL

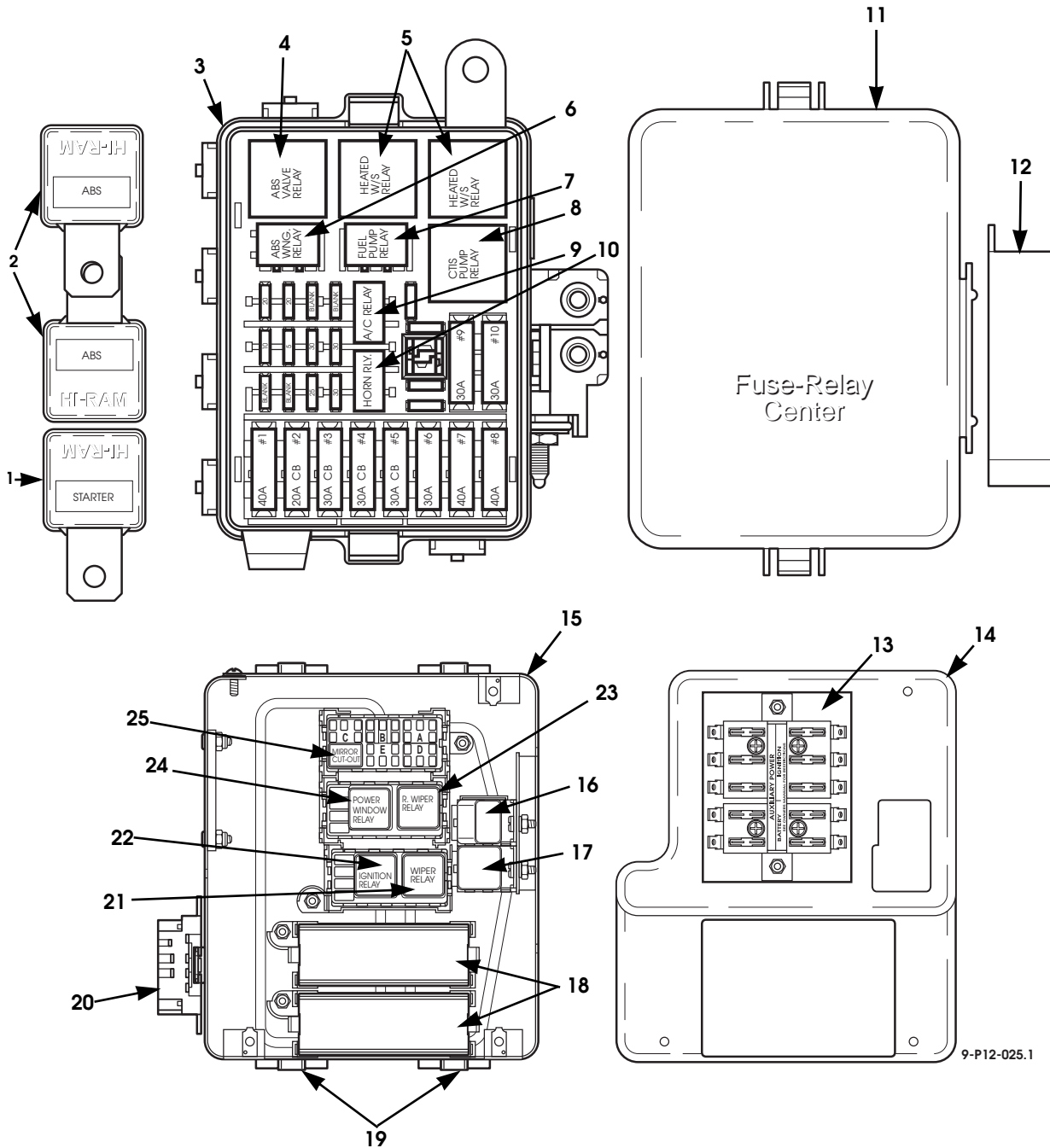

9-P12-025.1

Figure 12-35. Fuse Boxes, Internal & External

# 2001 HUMMER PARTS CATALOG

## ELECTRICAL 12-93

ITEM	PART NUMBER	DESCRIPTION	QTY
		<b>Figure 12-35.</b> <b>Fuse Boxes, Internal &amp; External</b>	
1	6010234	RELAY, 80-amp, starter . . . . .	1
2	6010234	RELAY, 80-amp, ABS . . . . .	2
3	N/S	FUSE BOX BASE, external . . . . .	1
4	6010442	RELAY, mini, ABS valve . . . . .	1
5	6010442	RELAY, heated windshield . . . . .	2
6	6010285	RELAY, micro (280 series), ABS warning . . . . .	1
7	6010285	RELAY, micro (280 series), fuel pump . . . . .	1
8	6010442	RELAY, mini, CTI . . . . .	1
9	6010285	RELAY, micro (280 series), A/C/ clutch . . . . .	1
10	6010285	RELAY, micro, (280 series), horn . . . . .	1
11	6010288	COVER, external fuse box . . . . .	1
12	6010255	COVER, external power studs . . . . .	1
13	6010403	FUSE PANEL, auxiliary . . . . .	1
14	6010127	COVER, internal fuse box . . . . .	1
15	6010140B9	FUSE BOX BASE, internal . . . . .	1
16	5939581	ALARM, CTI, low pressure . . . . .	1
17	6010136	FLASHER, turn signal and hazard . . . . .	1
18	5939722	COVER, fuse box . . . . .	2
19	5939908P	BRACKET ASSEMBLY, interior fuse box mounting . . . . .	2
20	6004890	CHIME MODULE . . . . .	1
21	6010442	RELAY, mini, windshield wiper . . . . .	1
22	6010442	RELAY, mini, ignition . . . . .	1
23	6010442	RELAY, mini, rear wiper . . . . .	1
24	6010442	RELAY, mini, power windows . . . . .	1
25	6010285	RELAY, micro, (280 series), power mirror cut-out . . . . .	1

**2001 HUMMER PARTS CATALOG**

**12-94 ELECTRICAL**

# 2001 HUMMER PARTS CATALOG

ELECTRICAL 12-95

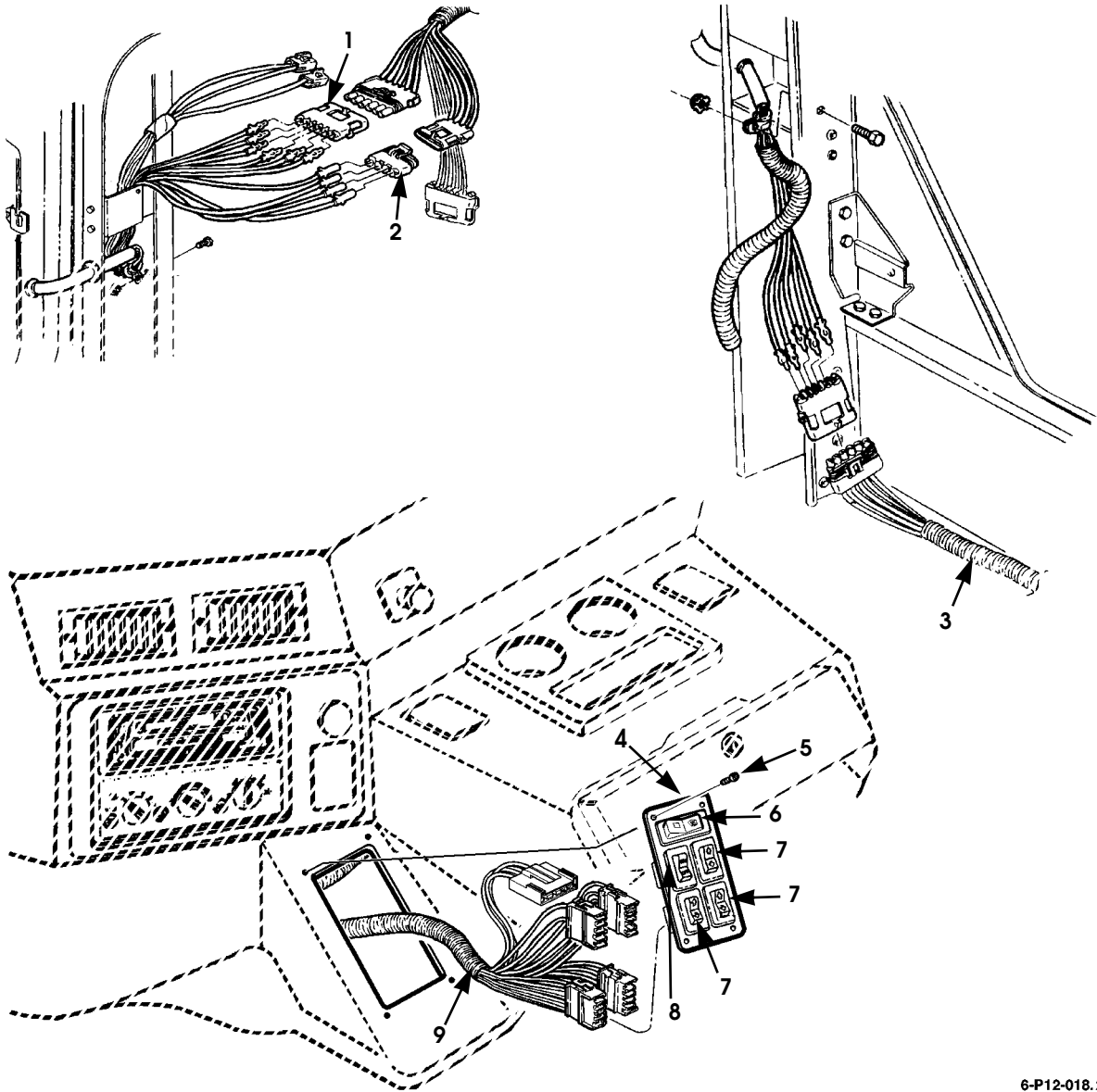

6-P12-018.2

Figure 12-36. Power Window  
(Sheet 1 of 2).

# 2001 HUMMER PARTS CATALOG

## 12-96 ELECTRICAL

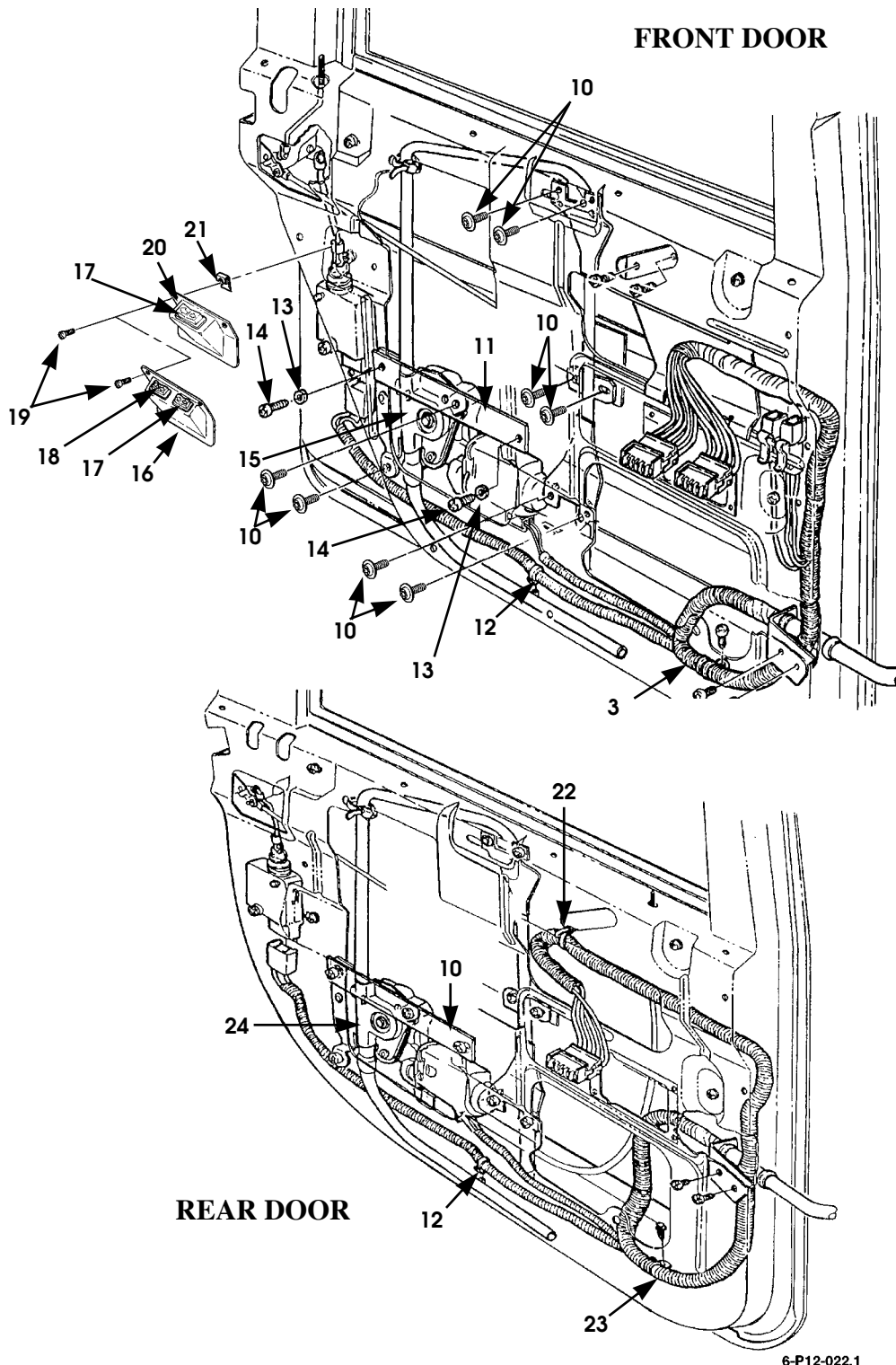

6-P12-022.1

Figure 12-36. Power Window (Sheet 2 of 2).

# 2001 HUMMER PARTS CATALOG

## ELECTRICAL 12-97

ITEM	PART NUMBER	DESCRIPTION	QTY
		<b>Figure 12-36. Power Windows.</b>	
1	5995713	CONNECTOR, 6-way . . . . .	2
2	5995715	CONNECTOR, 4-way . . . . .	2
3	6010864	HARNESS ASSEMBLY, front door, L.H. . . . .	1
3	6010865	HARNESS ASSEMBLY, front door, R.H. . . . .	1
4	6008742	PLATE, closeout . . . . .	1
4	6008728	PLATE, power window, w/o heated windshield 89 . . . . .	1
4	6008730	PLATE, power window, w/o heated windshield 83, 84, 90, 91. . . . .	1
4	6008741	PLATE, heated windshield, w/o power windows, SEE NOTE 1. . . . .	1
4	6011333	PLATE, heated windshield, w/o power windows,, SEE NOTE 2 83, 84, 89, 90. . . . .	1
4	6008728	PLATE, power window with heated windshield 89, SEE NOTE 1 . . . . .	1
4	6011331	PLATE, power window with heated windshield 89, SEE NOTE 2 . . . . .	1
4	6008730	PLATE, power window with heated windshield 83, 84, 90, 91, SEE NOTE 1 . . . . .	1
4	6011332	PLATE, power window with heated windshield 83, 84, 90, 91, SEE NOTE 2 . . . . .	1
5	5939651P2	SCREW . . . . .	4
6	6008768	SWITCH AND TIMER ASSEMBLY, heated windshield SEE NOTE 1. . . . .	1
6	6011330	SWITCH AND TIMER ASSEMBLY, heated windshield SEE NOTE 2. . . . .	1
7	6004185	SWITCH, power windows 89 . . . . .	1
7	6004185	SWITCH, power windows 83, 84, 90, 91. . . . .	3
8	6010756	SWITCH, power window lock . . . . .	1
9	6010029	HARNESS, console . . . . .	1
10	6003484	SCREW, window regulator . . . . .	8
11	6002866	BRACKET, window . . . . .	4
12	6002466	RETAINER. . . . .	4
13	N/S	LOCKWASHER, #8. . . . .	2
14	N/S	SCREW, #8 - 32 x 3/4, ZN . . . . .	2
15	6002870	REGULATOR, window L.H. . . . .	2
16	6003024	BEZEL, dual switch . . . . .	2
17	6002016	SWITCH, power door lock . . . . .	2
18	6004185	SWITCH, power window . . . . .	2
19	N/S	SCREW, #8 - 32 x 1/2, CAD. . . . .	2
20	6003023	BEZEL, single switch . . . . .	2
21	6003025	J-NUT. . . . .	4
22	MS3367-1	CABLE TIES . . . . .	22
23	6003592	HARNESS, rear door. . . . .	2
24	6002871	REGULATOR, window R.H. . . . .	2
	6003916	CAP, door plug (not illustrated) . . . . .	4
		NOTE 1: FOR VEHICLES WITH VIN BEFORE YE188965. NOTE 2: FOR VEHICLES WITH VIN YE188965 AND LATER.	

# 2001 HUMMER PARTS CATALOG

## 12-98 ELECTRICAL

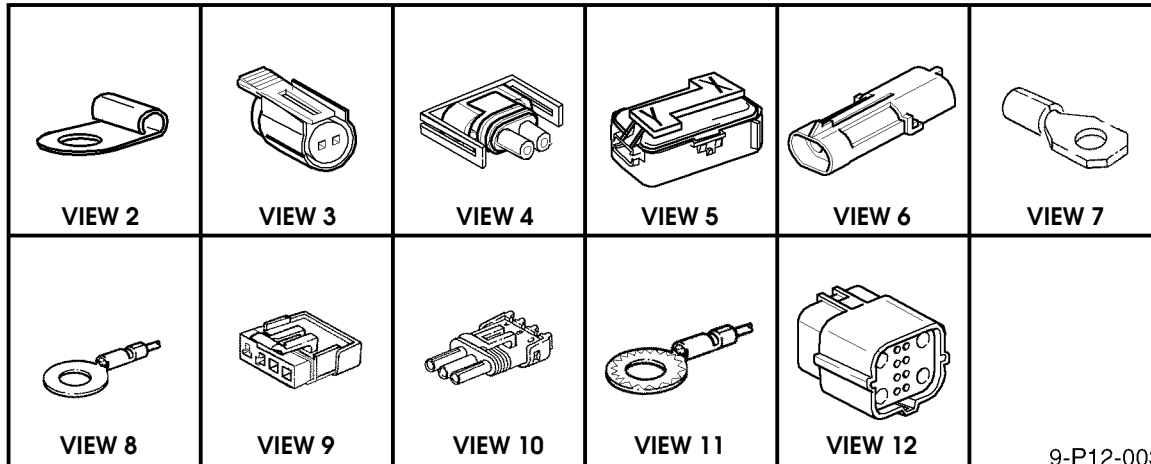
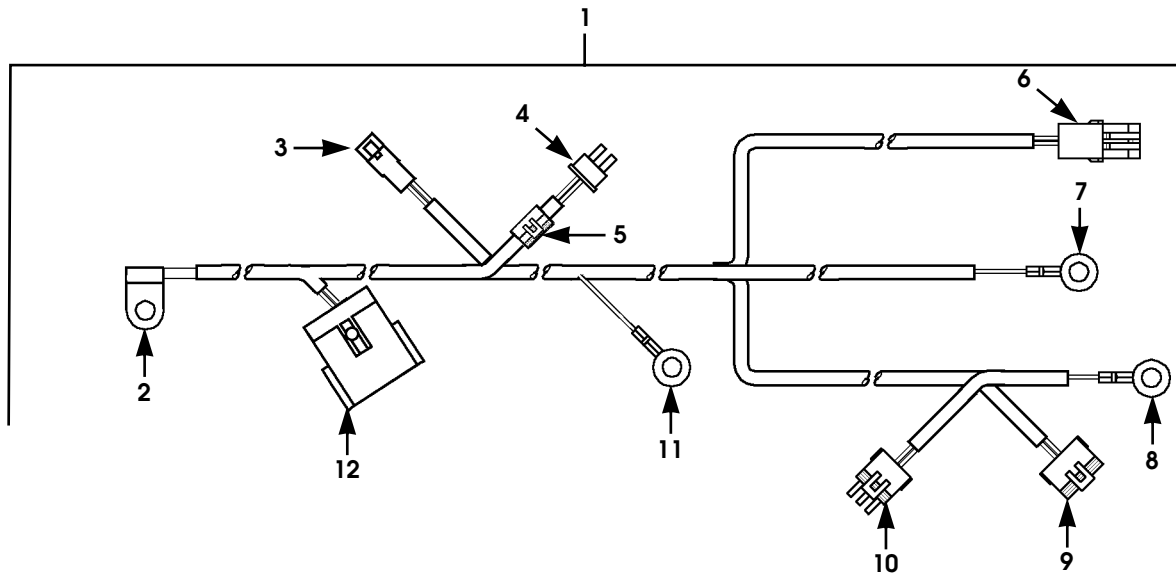

9-P12-003

Figure 12-37. Engine Harness Assembly, AM General.

# 2001 HUMMER PARTS CATALOG

## ELECTRICAL 12-99

ITEM	PART NUMBER	DESCRIPTION	QTY
		<b>Figure 12-37.</b> <b>Engine Harness Assembly, AM General.</b>	
1	6010026	HARNESS ASSEMBLY, engine . . . . .	1
2	S.I.A.	• POSITIVE POWER STUD . . . . .	1
3	S.I.A.	• CONNECTOR, A/C high pressure cut-out switch . . . .	1
4	S.I.A.	• CONNECTOR, A/C compressor . . . . .	1
5	S.I.A.	• DIODE, A/C compressor . . . . .	1
6	5939099	• CONNECTOR, A/C low pressure switch . . . . .	1
7	S.I.A.	• TERMINAL RING, starter solenoid . . . . .	1
8	S.I.A.	• TERMINAL RING, alternator . . . . .	1
9	5937091	• CONNECTOR, alternator . . . . .	1
10	5937082	• CONNECTOR, low coolant sensor . . . . .	1
11	S.I.A.	• TERMINAL RING, ground . . . . .	1
12	S.I.A.	• CONNECTOR, cowl harness . . . . .	1



# 2001 HUMMER PARTS CATALOG

## 12-100 ELECTRICAL

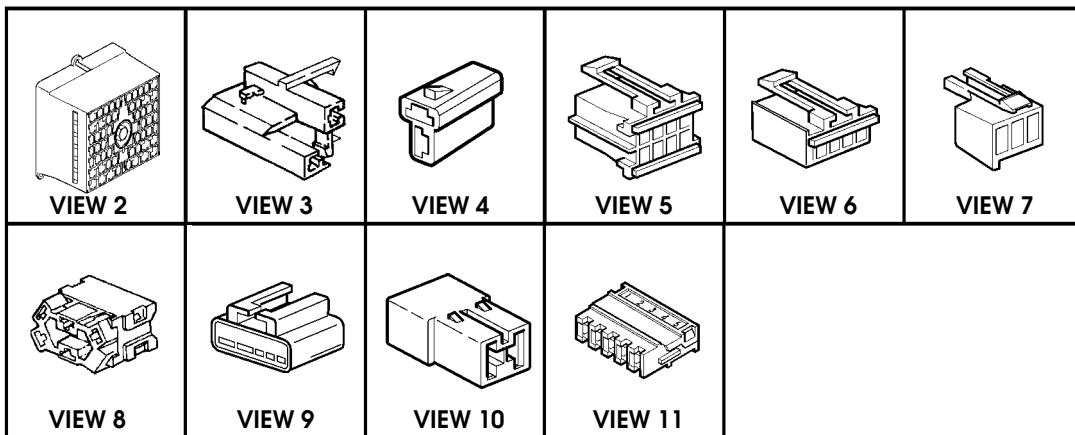
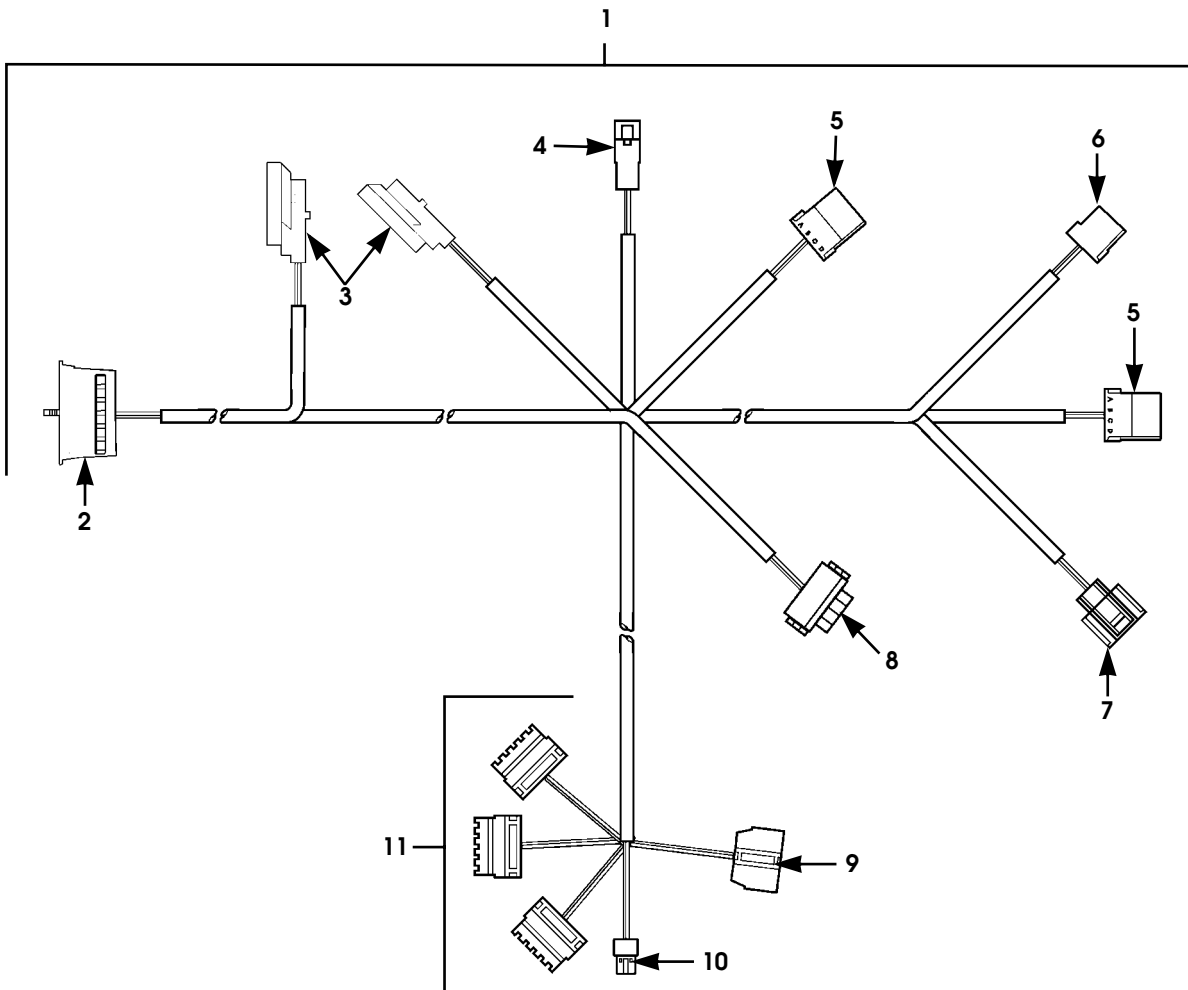

9-P12-005.1

Figure 12-38. Console Harness Assembly.

# 2001 HUMMER PARTS CATALOG

## ELECTRICAL 12-101

ITEM	PART NUMBER	DESCRIPTION	QTY
		<b>Figure 12-38. Console Harness Assembly.</b>	
1	6010029	HARNESS ASSEMBLY, console . . . . .	1
2	6010112	•CONNECTOR, console, 56 way . . . . .	1
3	5939641	•CONNECTOR, cigar lighter. . . . .	2
4	5903116	•CONNECTOR, auxiliary power outlet . . . . .	1
5	6002769	•CONNECTOR, main HVAC and audio harness . . . . .	2
6	6009408	•CONNECTOR, HVAC rear window defroster . . . . .	1
7	6009403	•CONNECTOR, HVAC blower. . . . .	1
8	5939891	•CONNECTOR, rear blower switch . . . . .	1
9	6005201	•CONNECTOR, heated windshield timer switch . . . . .	1
10	6010757	•CONNECTOR, window lock switch . . . . .	1
11	6002930	•CONNECTOR, power windows . . . . .	3

# 2001 HUMMER PARTS CATALOG

## 12-102 ELECTRICAL

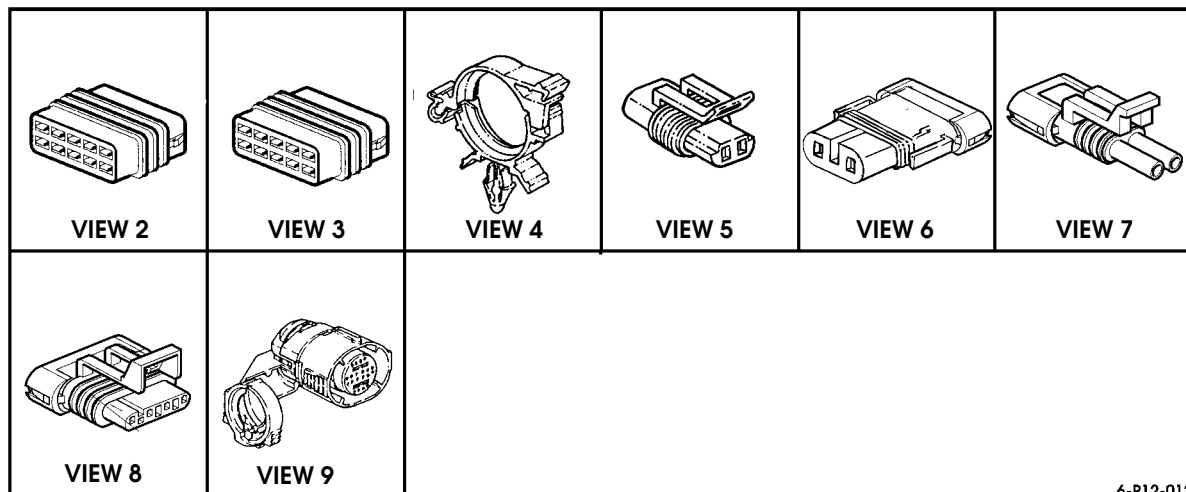
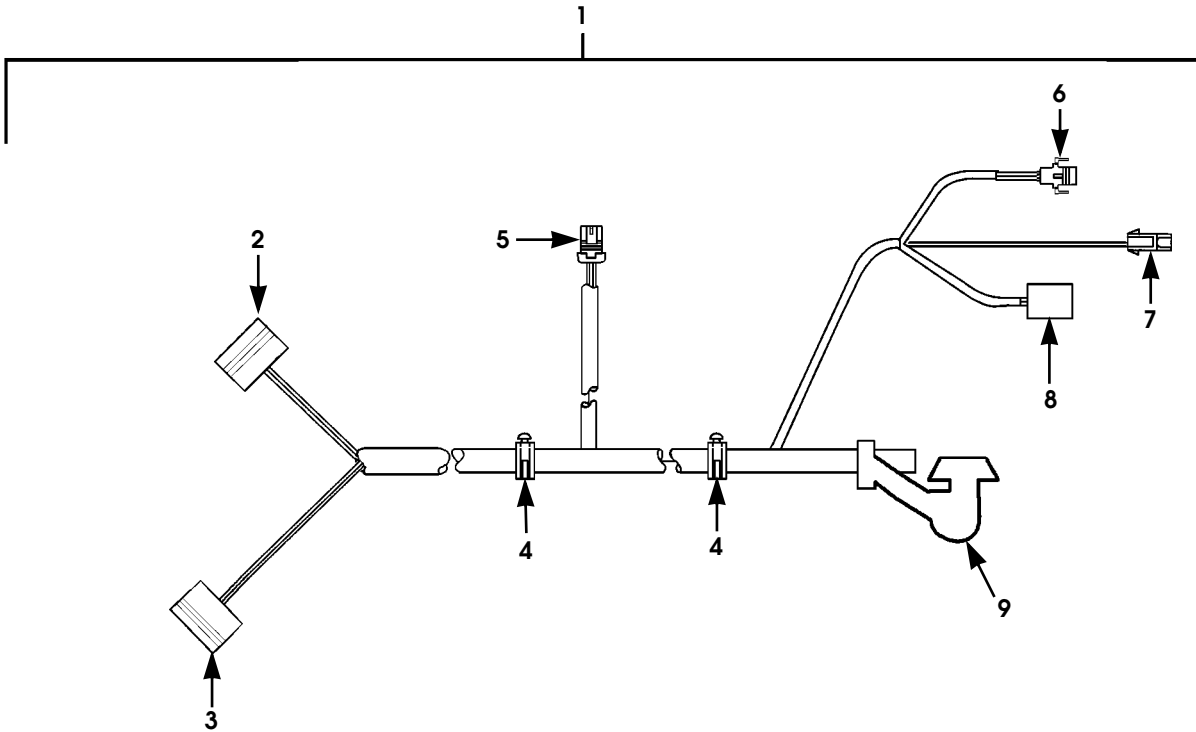

6-P12-012

Figure 12-39. Transmission Harness Assembly.

# 2001 HUMMER PARTS CATALOG

## ELECTRICAL 12-103

ITEM	PART NUMBER	DESCRIPTION	QTY
		<b>Figure 12-39.</b> <b>Transmission Harness Assembly.</b>	
1	6010027	HARNESS ASSEMBLY, transmission . . . . .	1
2	6006958	•CONNECTOR, 10-way, cowl harness . . . . .	1
3	S.I.A.	•CONNECTOR, cowl harness . . . . .	1
4	5903019	•CLIP, convoluted tubing . . . . .	2
5	6003235	•CONNECTOR, 2-way, transmission input speed sensor	1
6	6005118	•CONNECTOR, vehicle speed sensor . . . . .	1
7	S.I.A.	•CONNECTOR, transfer case lock switch . . . . .	1
8	6004449	•CONNECTOR, 3-way, transfer range switch . . . . .	1
9	S.I.A.	•CONNECTOR, transmission . . . . .	1

# 2001 HUMMER PARTS CATALOG

## 12-104 ELECTRICAL

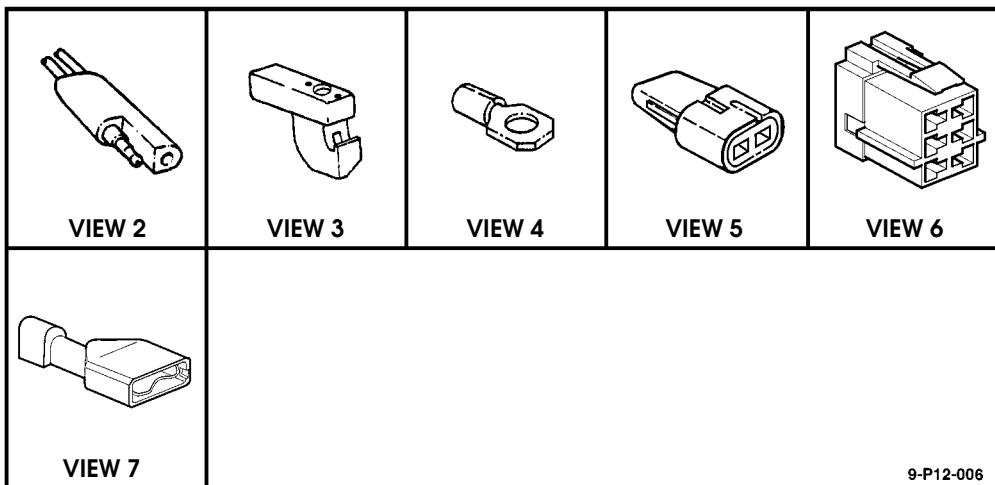
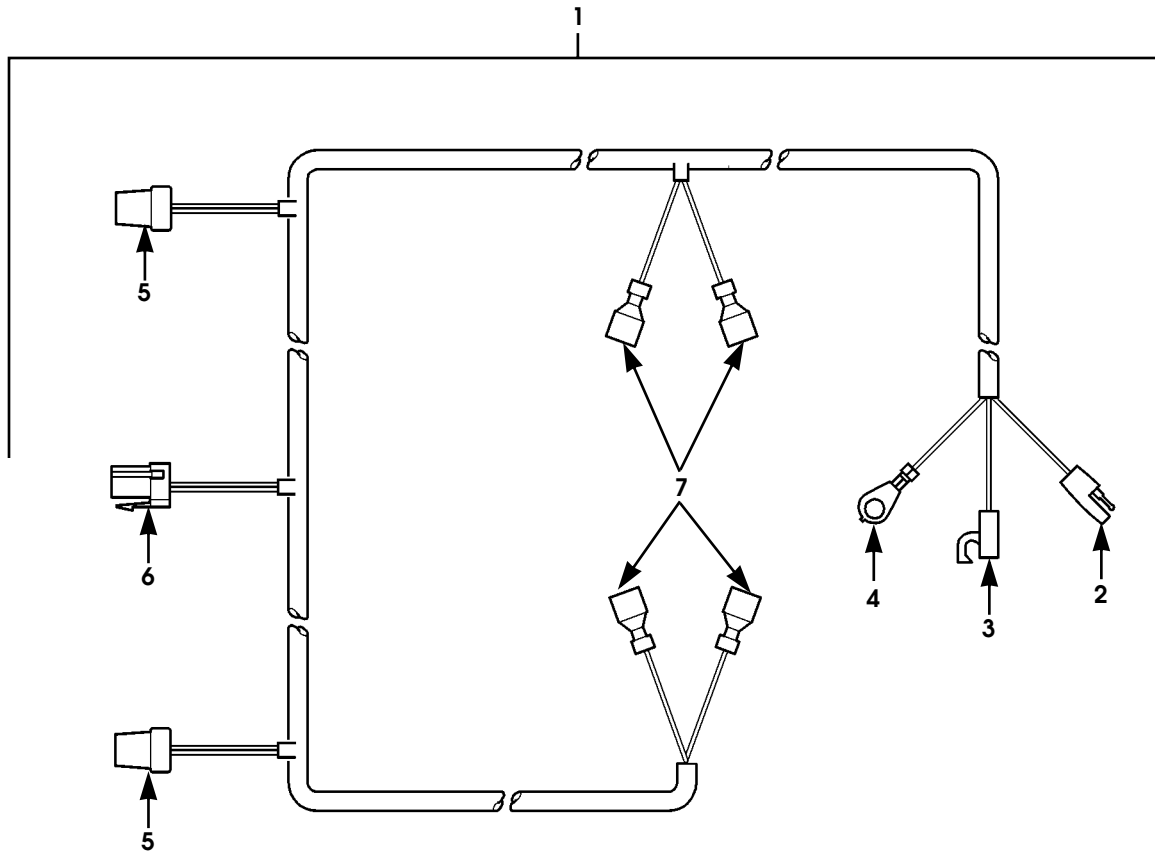

9-P12-006

Figure 12-40. Roof Wiring Harness Assembly, Two-Door, Model 89.

# 2001 HUMMER PARTS CATALOG

## ELECTRICAL 12-105

ITEM	PART NUMBER	DESCRIPTION	QTY
		<b>Figure 12-40. Roof Wiring Harness Assembly, Two-Door, Model 89.</b>	
1	6010030	HARNESS ASSEMBLY, roof wiring, two-door . . . . . 89	1
2	6000972	•CONNECTOR, cargo light . . . . .	1
3	5939096	•CONNECTOR, dome lamp . . . . .	1
4	S.I.A.	•TERMINAL RING, dome lamp . . . . .	1
5	S.I.A.	•CONNECTOR, visor light . . . . .	2
6	S.I.A.	•CONNECTOR, cross body harness . . . . .	1
7	S.I.A.	•TERMINAL, crimp-on spade, female . . . . .	4

# 2001 HUMMER PARTS CATALOG

## 12-106 ELECTRICAL

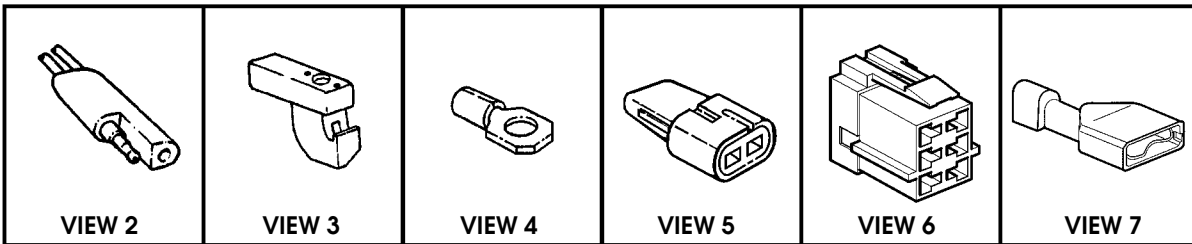
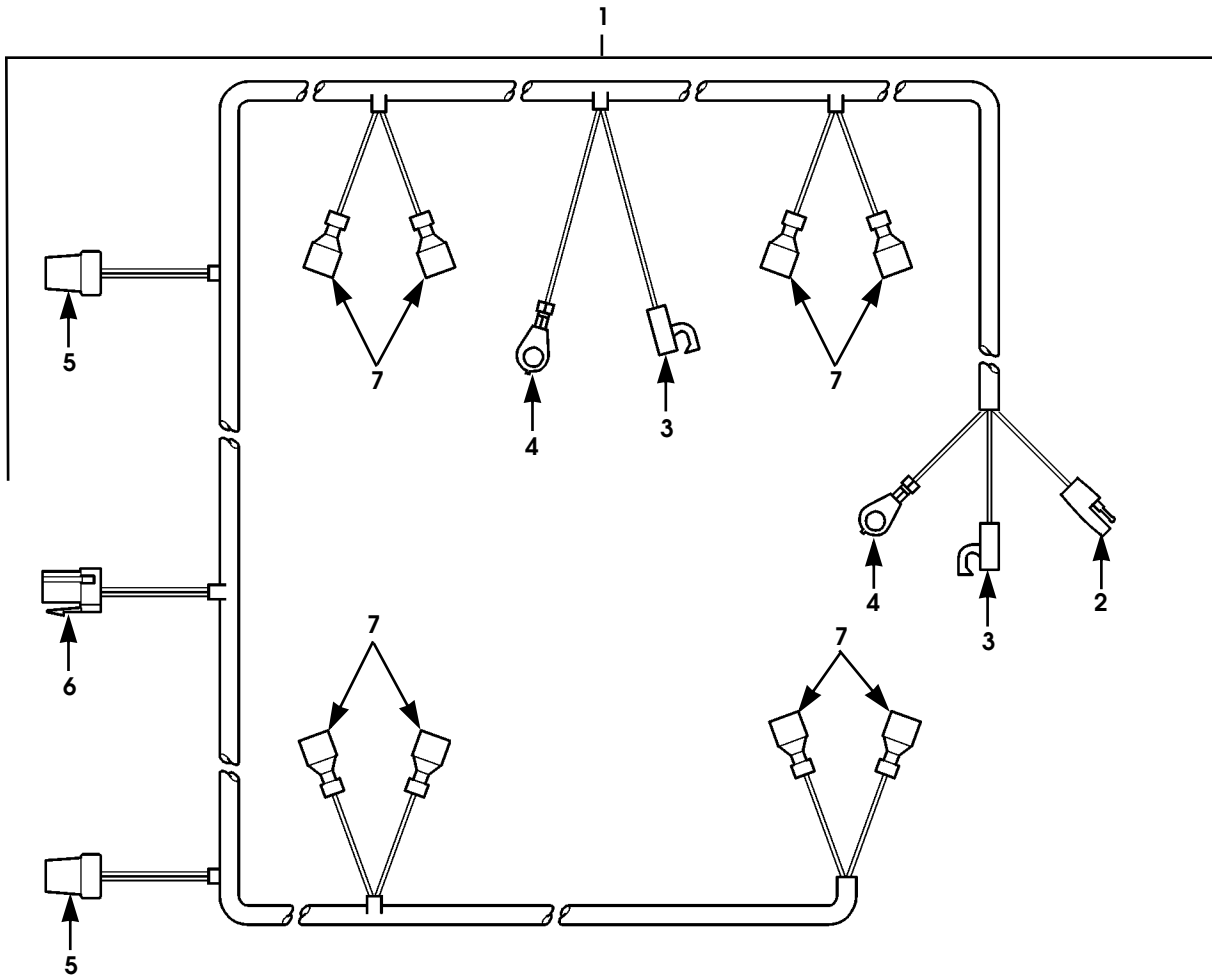

9-P12-008

Figure 12-41. Roof Wiring Harness Assembly, Four-Door, Model 83.

# 2001 HUMMER PARTS CATALOG

## ELECTRICAL 12-107

ITEM	PART NUMBER	DESCRIPTION	QTY
		<b>Figure 12-41. Roof Wiring Harness Assembly, Four-Door, Model 83.</b>	
1	6010031	HARNESS ASSEMBLY, roof wiring, four-door . . . . . 83	1
2	6000972	•CONNECTOR, cargo light . . . . .	1
3	5939096	•CONNECTOR, dome lamp . . . . .	1
4	S.I.A.	•TERMINAL RING, dome lamp . . . . .	1
5	S.I.A.	•CONNECTOR, visor light . . . . .	2
6	S.I.A.	•CONNECTOR, cross body harness . . . . .	1
7	S.I.A.	•TERMINAL, crimp-on spade, female . . . . .	4



# 2001 HUMMER PARTS CATALOG

## 12-108 ELECTRICAL

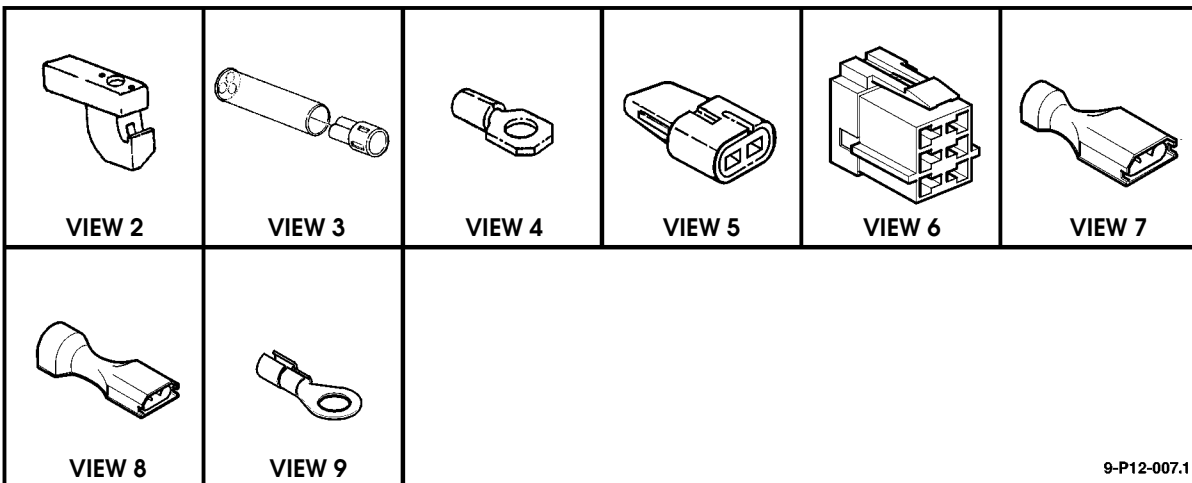
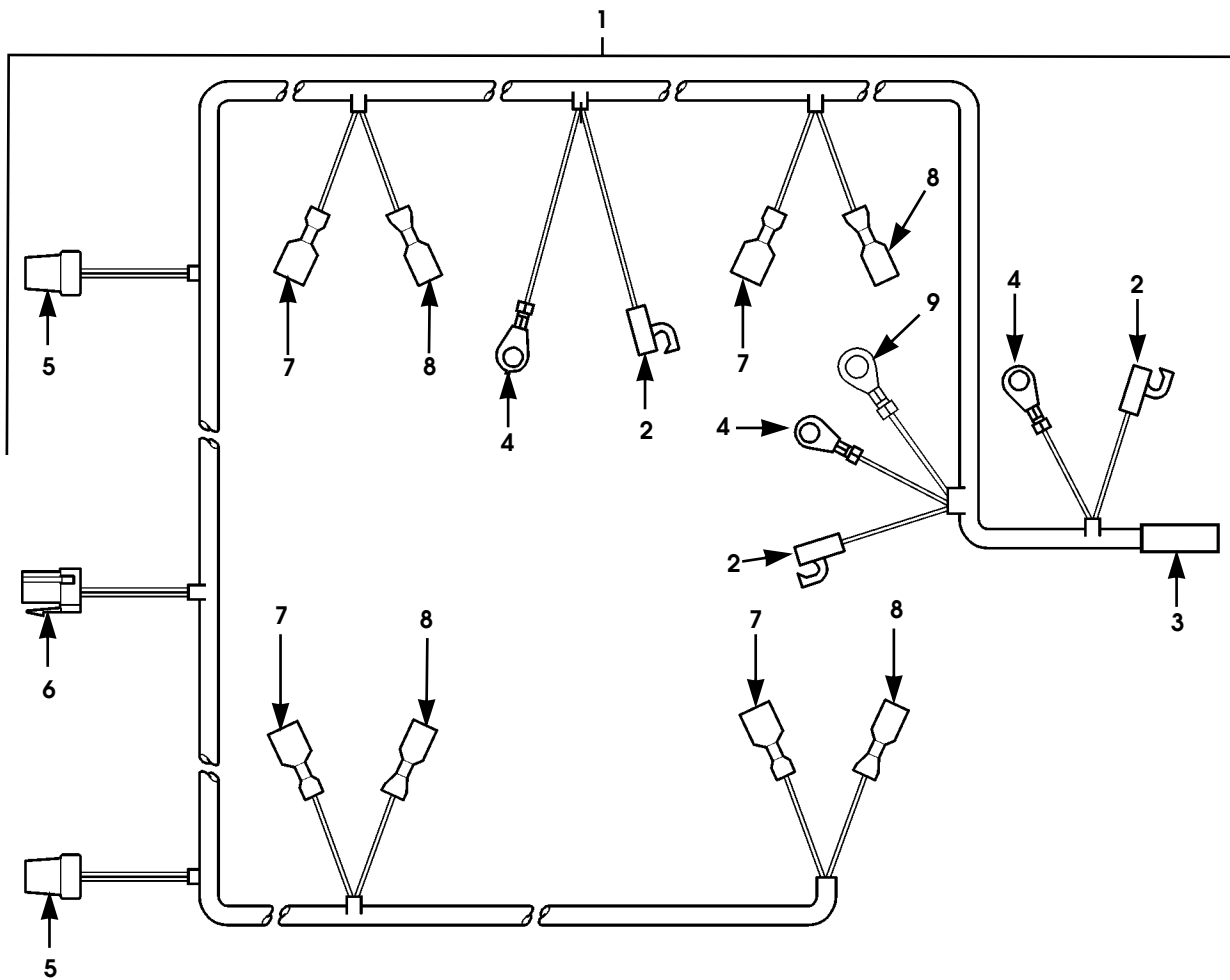

9-P12-007.1

Figure 12-42. Roof Wiring Harness Assembly, Station Wagon, Model 84.

# 2001 HUMMER PARTS CATALOG

## ELECTRICAL 12-109

ITEM	PART NUMBER	DESCRIPTION	QTY
		<b>Figure 12-42.</b> <b>Roof Wiring Harness Assembly, Station Wagon, Model 84.</b>	
1	6010032	HARNESS ASSEMBLY, roof wiring, station wagon . . . . . 84	1
2	5939096	•CONNECTOR, dome light switch . . . . .	1
3	5939085	•CONNECTOR, rear door cargo lamp switch . . . . .	1
4	S.I.A.	•RING TERMINAL, dome light . . . . .	1
5	S.I.A.	•CONNECTOR, visor light . . . . .	2
6	S.I.A.	•CONNECTOR, cross body harness . . . . .	1
7	S.I.A.	•TERMINAL, crimp-on spade, female . . . . .	4
8	S.I.A.	•TERMINAL, crimp-on spade, female . . . . .	4
9	S.I.A.	•RING TERMINAL, rear dome lamp . . . . .	1

# 2001 HUMMER PARTS CATALOG

## 12-110 ELECTRICAL

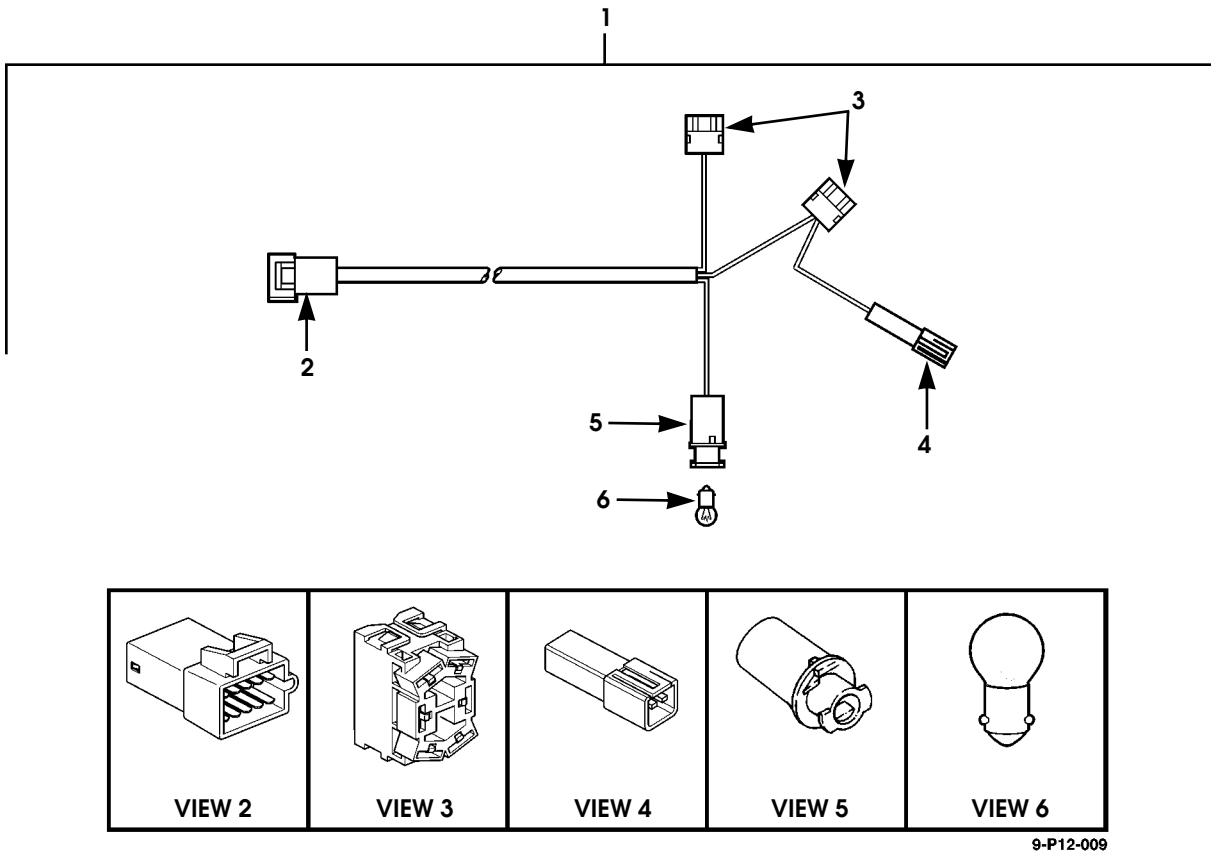

Figure 12-43. CTIS Interior Harness Assembly

# 2001 HUMMER PARTS CATALOG

## ELECTRICAL 12-111

ITEM	PART NUMBER	DESCRIPTION	QTY
		<b>Figure 12-43.</b> <b>CTIS Interior Harness Assembly</b>	
1	6010028	HARNESS ASSEMBLY, CTIS interior .....	1
2	S.I.A.	•CONNECTOR, I.P.harness .....	1
3	S.I.A.	•CONNECTOR, compressor switch .....	2
4	5939154	•CONNECTOR, switch illumination .....	1
5	S.I.A.	•LAMP SOCKET, CTIS gauge. ....	1
6	S.I.A.	•BULB, #1815 .....	1

# 2001 HUMMER PARTS CATALOG

## 12-112 ELECTRICAL

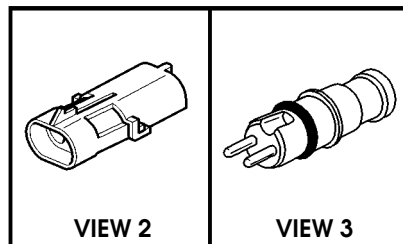
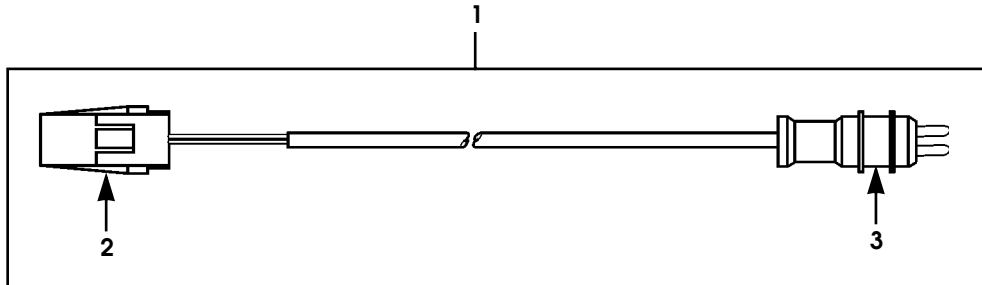

9-P12-010

Figure 12-44. Right Front Wheel Sensor Jumper Harness Assembly.

# 2001 HUMMER PARTS CATALOG

## ELECTRICAL 12-113

ITEM	PART NUMBER	DESCRIPTION	QTY
		<b>Figure 12-44.</b> <b>Right Front Wheel Sensor Jumper Harness Assembly.</b>	
1	6010137	JUMPER HARNESS ASSEMBLY, right front wheel sensor.	1
2	N/S	•CONNECTOR, underbody harness . . . . .	1
3	N/S	•CONNECTOR, wheel sensor, right front . . . . .	1

# 2001 HUMMER PARTS CATALOG

## 12-114 ELECTRICAL

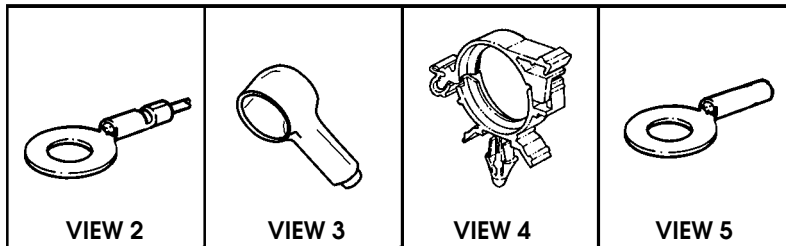
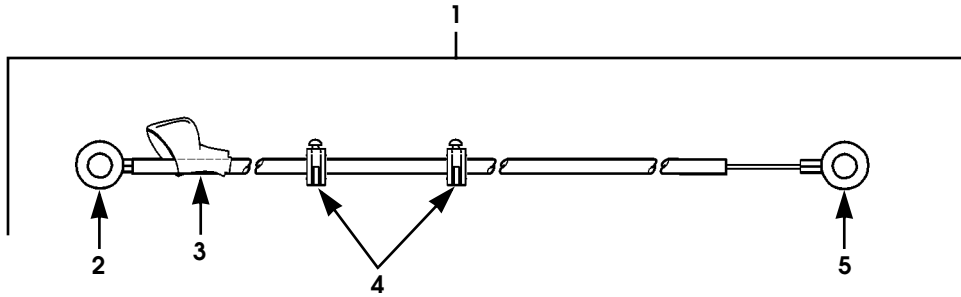

9-P12-013

Figure 12-45. Glow Plug Power Cable Assembly.

# 2001 HUMMER PARTS CATALOG

## ELECTRICAL 12-115

ITEM	PART NUMBER	DESCRIPTION	QTY
		<b>Figure 12-45. Glow Plug Power Cable Assembly.</b>	
1	6010339	CABLE ASSEMBLY, glow plug power. . . . .	1
2	S.I.A.	•RING TERMINAL, glow plug controller . . . . .	1
3	S.I.A.	•BOOT, terminal. . . . .	1
4	5903019	•CLIP, conduit. . . . .	2
5	S.I.A.	•RING TERMINAL, starter . . . . .	1



# 2001 HUMMER PARTS CATALOG

## 12-116 ELECTRICAL

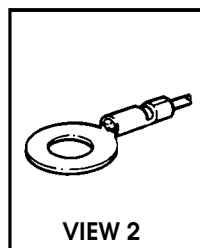
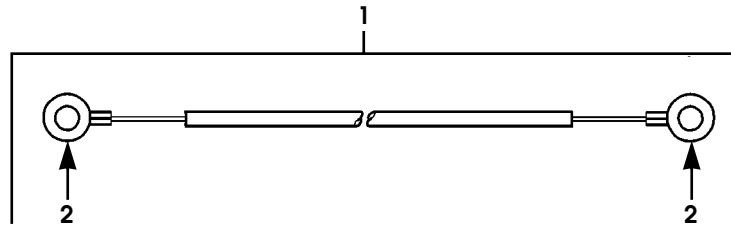

9-P12-012

*Figure 12-46. Interior Ground Cable Assembly.*

# 2001 HUMMER PARTS CATALOG

**ELECTRICAL 12-117**

ITEM	PART NUMBER	DESCRIPTION	QTY
1	6010377	<b>Figure 12-46.</b> <b>Interior Ground Cable Assembly.</b>  CABLE ASSEMBLY, interior ground. . . . .	1
2	N/S	•RING TERMINAL, ground . . . . .	2

# 2001 HUMMER PARTS CATALOG

## 12-118 ELECTRICAL

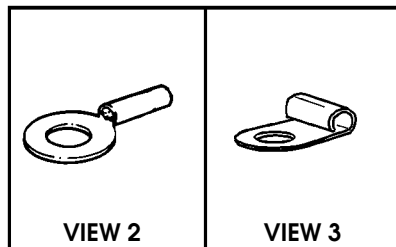
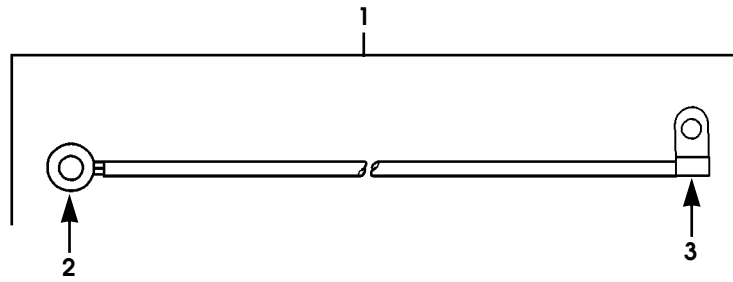

9-P12-011

*Figure 12-47. Exterior Fuse Box Power Cable.*

# 2001 HUMMER PARTS CATALOG

**ELECTRICAL 12-119**

ITEM	PART NUMBER	DESCRIPTION	QTY
		<b>Figure 12-47.</b> <b>Exterior Fuse Box Power Cable.</b>	
1	6010349	CABLE, power, exterior fuse box. ....	1
2	S.I.A.	•RING TERMINAL .....	1
3	S.I.A.	•FLAG TERMINAL .....	1

# 2001 HUMMER PARTS CATALOG

## 12-120 ELECTRICAL

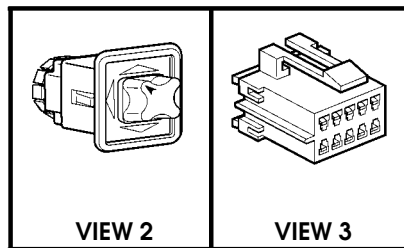
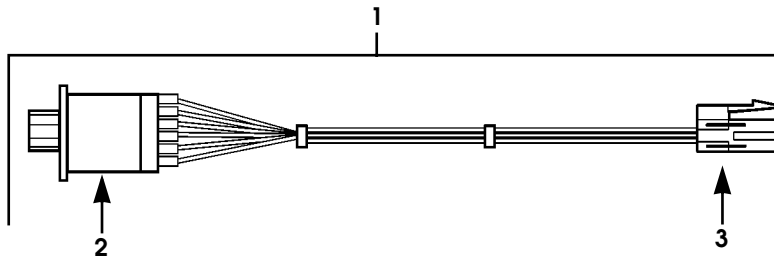

9-P12-015

Figure 12-48. Power Mirror Switch Harness Assembly.

# 2001 HUMMER PARTS CATALOG

## ELECTRICAL 12-121

ITEM	PART NUMBER	DESCRIPTION	QTY
		<b>Figure 12-48.</b> <b>Power Mirror Switch Harness Assembly.</b>	
1	6010091	HARNESS ASSEMBLY, power mirror switch . . . . .	1
2	6003849	•SWITCH, power mirror . . . . .	1
3	6003227	•CONNECTOR, engine harness . . . . .	1

# 2001 HUMMER PARTS CATALOG

## 12-122 ELECTRICAL

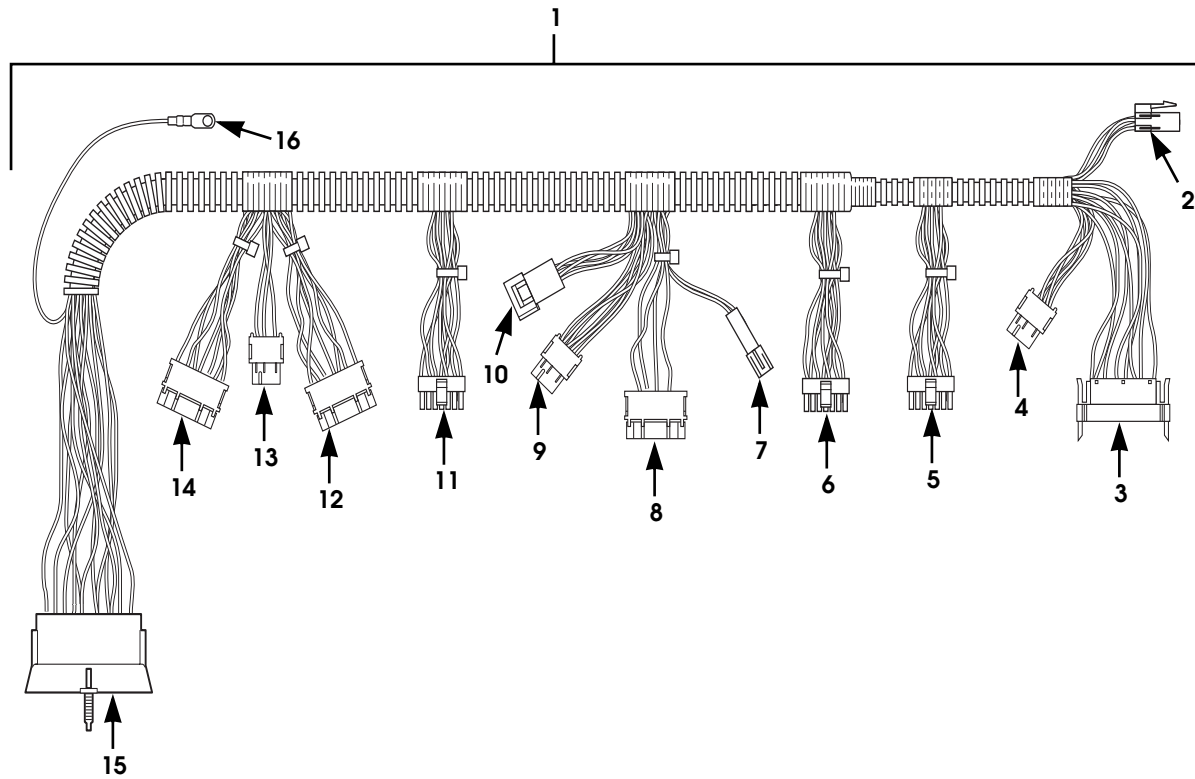

VIEW 2	VIEW 3	VIEW 4, 9	VIEW 5, 6, 11	VIEW 7	VIEW 8
VIEW 10	VIEW 12	VIEW 13	VIEW 14	VIEW 15	VIEW 16

01-P12-008

Figure 12-49. Instrument Panel Harness.

# 2001 HUMMER PARTS CATALOG

## ELECTRICAL 12-123

ITEM	PART NUMBER	DESCRIPTION	QTY
		<b>Figure 12-49.</b> <b>Instrument Panel Harness.</b>	
1	6011636	HARNESS ASSEMBLY, instrument panel. . . . .	1
2	6003227	•CONNECTOR, 10-way, CTI harness . . . . .	1
3	6010230	•CONNECTOR, 10-way, fuel tank selector switch . . . .	1
4	6010228	•CONNECTOR, 6-way, gray, rear wiper/washer switch	1
5	6011648	•CONNECTOR, 14-way, water ramp, fuel gauges . . . .	1
6	6011648	•CONNECTOR, 14-way, speedometer tach. . . . .	1
7	6000135	•CONNECTOR, 2-way, wiper switch illumination . . . . .	1
8	5939891	•CONNECTOR, 6-way, wiper switch . . . . .	1
9	6010228	•CONNECTOR, 6-way, gray, intermitant switch . . . . .	1
10	6003256	•SWITCH, power mirror . . . . .	1
11	6011648	•CONNECTOR, 14-way, volt/oil pressure . . . . .	1
12	5939900	•CONNECTOR, 6-way, dome lamp switch . . . . .	1
13	6010227	•CONNECTOR, 6-way, black, panel dimmer . . . . .	1
14	5939898	•CONNECTOR, 6-way, light switch. . . . .	1
15	6010112	•CONNECTOR, 56-way, cross body harness. . . . .	1
16	6011650	•RING TERMINAL, ground . . . . .	1



# 2001 HUMMER PARTS CATALOG

## 12-124 ELECTRICAL

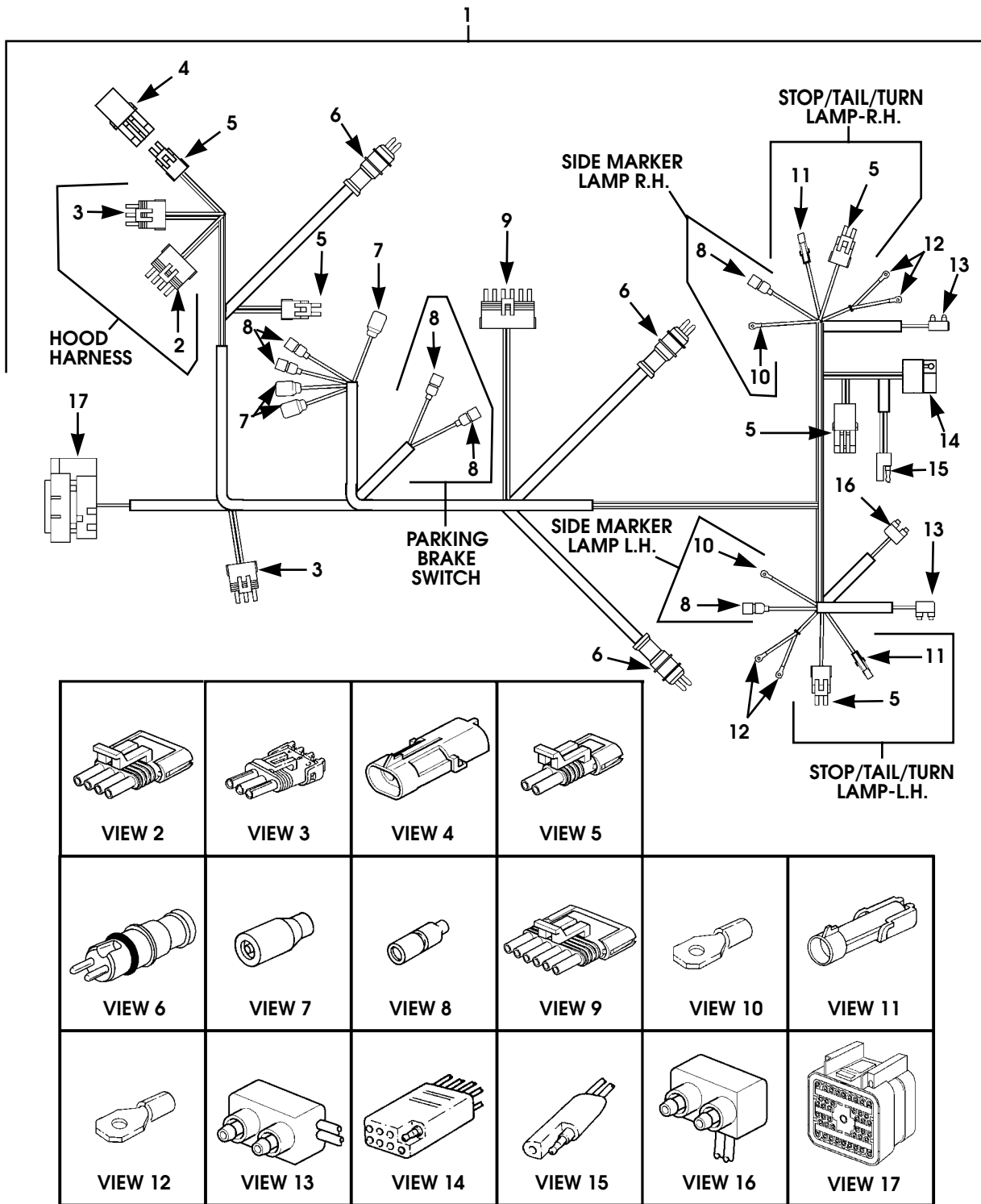

9-P12-018.1

Figure 12-50. Underbody Harness, Rear.

# 2001 HUMMER PARTS CATALOG

## ELECTRICAL 12-125

ITEM	PART NUMBER	DESCRIPTION	QTY
		<b>Figure 12-50. Underbody Harness, Rear.</b>	
1	6011021	HARNESS ASSEMBLY, underbody, rear . . . . .	1
2	5995715	•CONNECTOR, 4-way . . . . .	1
3	5937082	•CONNECTOR, 3-way . . . . .	2
4	5939099	•CONNECTOR, ambient temperature . . . . .	1
5	6005581	•CONNECTOR, 2-way, gray . . . . .	1
5	S.I.A.	•CONNECTOR, 2-way, black . . . . .	1
6	S.I.A.	•CABLE ASSEMBLY, wheel sensor, left front . . . . .	1
6	S.I.A.	•CABLE ASSEMBLY, wheel sensor, right rear. . . . .	1
6	S.I.A.	•CABLE ASSEMBLY, wheel sensor, left rear. . . . .	1
7	MS27142-3	•CONNECTOR . . . . .	3
8	MS27144-2	•CONNECTOR . . . . .	6
9	S.I.A.	•CONNECTOR, main fuel tank. . . . .	1
10	5903147	•RING TERMINAL . . . . .	2
11	5939237	•PLUG, connector, male. . . . .	2
12	S.I.A.	•RING TERMINAL . . . . .	4
13	5937021	•CONNECTOR, mold-on. . . . .	2
14	5937038	•CONNECTOR, mold-on, trailer connection . . . . .	1
15	S.I.A.	•CONNECTOR, mold-on, rear identification lights. . . . .	1
16	5937039	•CONNECTOR, mold-on. . . . .	1
17	S.I.A.	•CONNECTOR, cowl harness. . . . .	1

# 2001 HUMMER PARTS CATALOG

## 12-126 ELECTRICAL

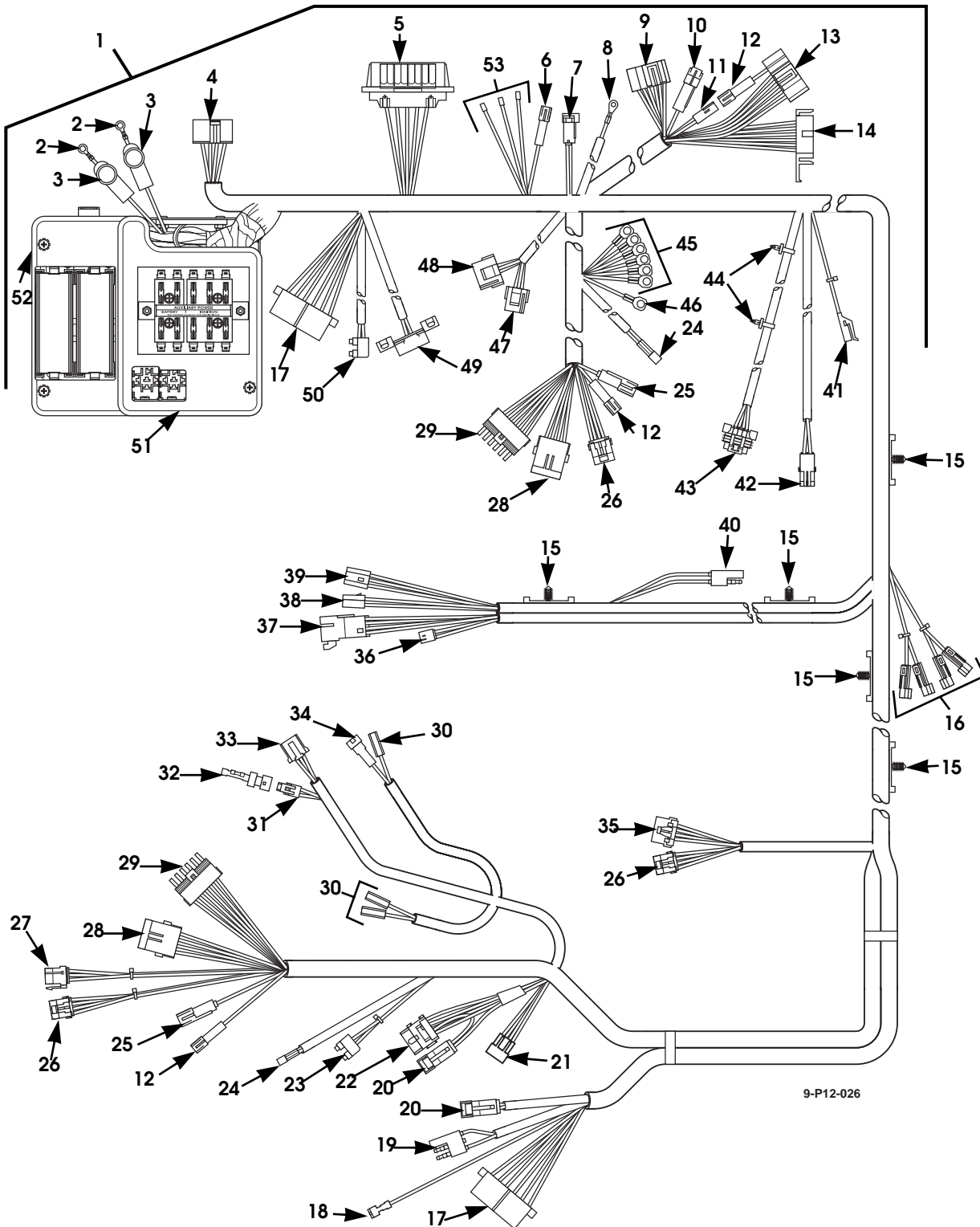

9-P12-026

Figure 12-51. Cross Body Harness  
(Sheet 1 of 3).

# 2001 HUMMER PARTS CATALOG

## ELECTRICAL 12-127

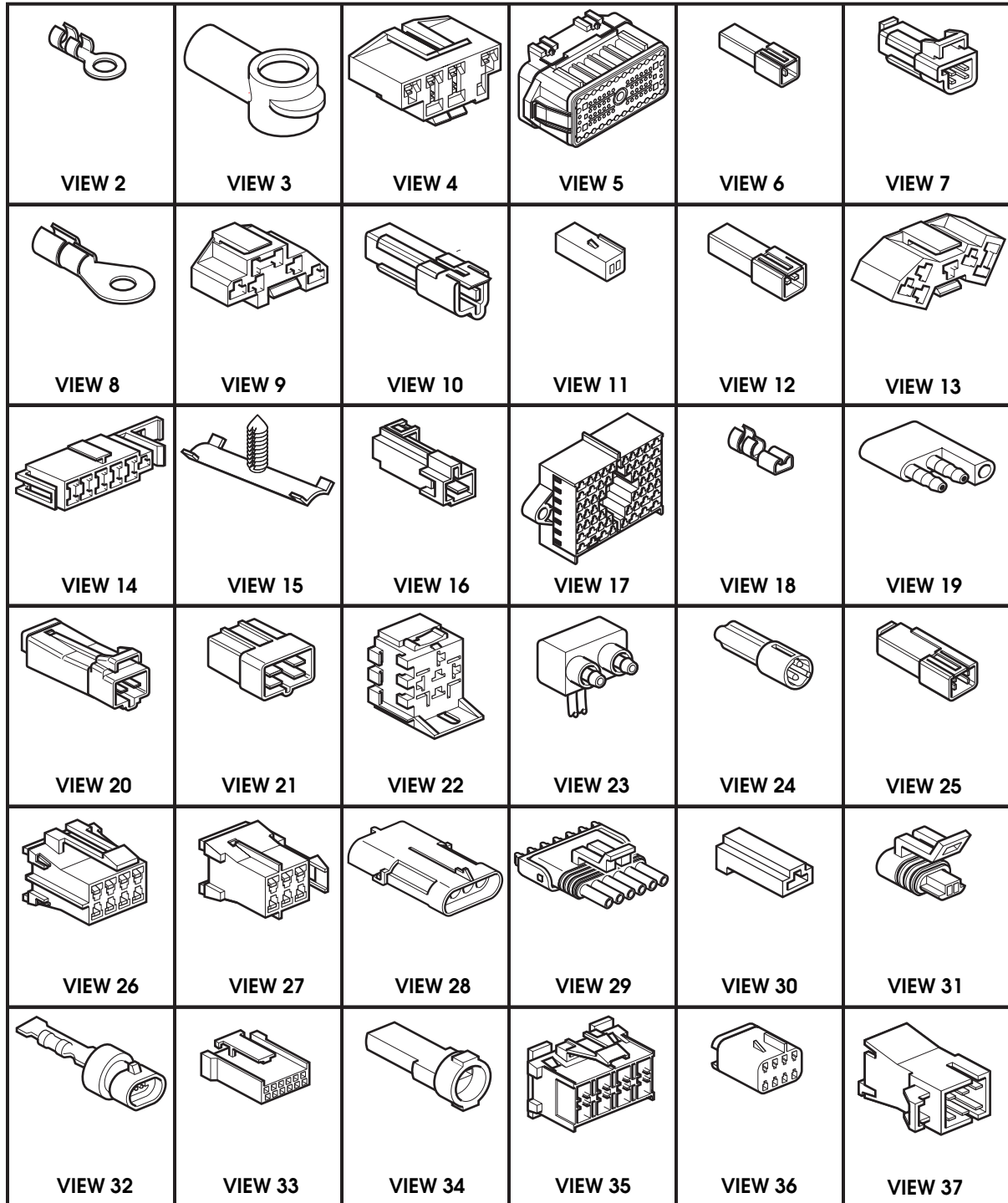

9-P12-026A

Figure 12-51. Cross Body Harness  
(Sheet 2 of 3).

# 2001 HUMMER PARTS CATALOG

## 12-128 ELECTRICAL

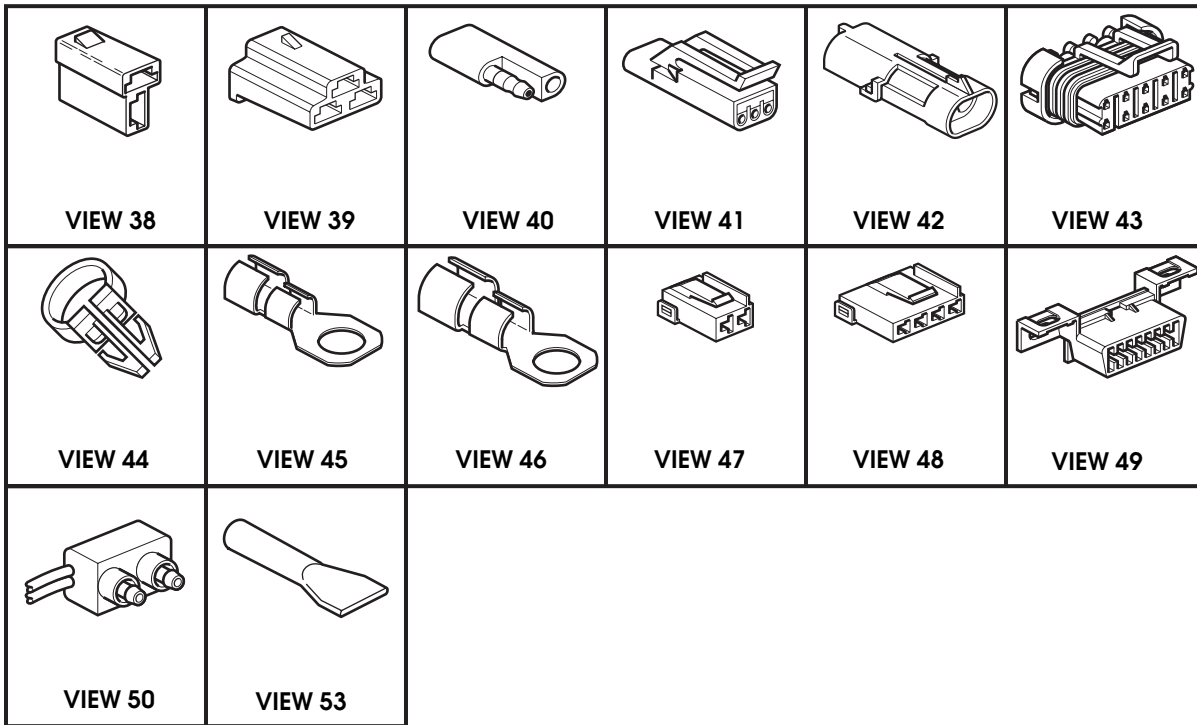

9-P12-026B

*Figure 12-51. Cross Body Harness  
(Sheet 3 of 3).*

# 2001 HUMMER PARTS CATALOG

## ELECTRICAL 12-129

ITEM	PART NUMBER	DESCRIPTION	QTY
		<b>Figure 12-51. Cross Body Harness.</b>	
1	6011635	CROSS BODY HARNESS ASSEMBLY . . . . .	1
2	S.I.A.	•EYELET, terminal . . . . .	2
3	S.I.A.	•BOOT, red . . . . .	2
4	S.I.A.	•CONNECTOR, male . . . . .	1
5	S.I.A.	•CONNECTOR, 76-way . . . . .	1
6	6004020	•CONNECTOR, male . . . . .	1
7	5939599	•CONNECTOR . . . . .	1
8	5903147	•TERMINAL RING . . . . .	1
9	6000134	•SLEEVE . . . . .	1
10	6000141	•SLEEVE . . . . .	1
11	S.I.A.	•CONNECTOR . . . . .	1
12	S.I.A.	•CONNECTOR . . . . .	3
13	6000142	•SLEEVE . . . . .	1
14	6000143	•SLEEVE . . . . .	1
15	S.I.A.	•CLIP . . . . .	5
16	S.I.A.	•CONNECTOR, one-way . . . . .	4
17	S.I.A.	•CONNECTOR, 56-way . . . . .	2
18	S.I.A.	•TERMINAL, amp . . . . .	1
19	S.I.A.	•CONNECTOR . . . . .	1
20	S.I.A.	•CONNECTOR . . . . .	2
21	S.I.A.	•CONNECTOR . . . . .	1
22	S.I.A.	•CONNECTOR . . . . .	1
23	5937039	•CONNECTOR . . . . .	1
24	5939085	•CONNECTOR, door switch . . . . .	2
25	S.I.A.	•CONNECTOR . . . . .	2
26	6002769	•CONNECTOR . . . . .	3
27	S.I.A.	•CONNECTOR . . . . .	1
28	5995732	•INSULATOR, hard shell . . . . .	2
29	5995714	•CONNECTOR, six-way . . . . .	2
30	5903092	•INSULATOR . . . . .	3
31	6003235	•CONNECTOR, two-way . . . . .	1
32	S.I.A.	•RESISTOR MODULE . . . . .	1
33	S.I.A.	•CONNECTOR . . . . .	1
34	S.I.A.	•JUMPER ASSEMBLY . . . . .	1
35	6002769	•CONNECTOR . . . . .	1
36	6007226	•CONNECTOR . . . . .	1
37	S.I.A.	•CONNECTOR . . . . .	1

# 2001 HUMMER PARTS CATALOG

## 12-130 ELECTRICAL

ITEM	PART NUMBER	DESCRIPTION	QTY
		<b>Figure 12-51.</b> <b>Cross Body Harness (Cont'd)</b>	
38	5936490	•CONNECTOR . . . . .	1
39	5962328	•CONNECTOR . . . . .	1
40	S.I.A.	•INSULATOR AND SOCKET . . . . .	1
41	6000150	•CONNECTOR . . . . .	1
42	5939099	•CONNECTOR . . . . .	1
43	6006958	•CONNECTOR, 10-way . . . . .	1
44	S.I.A.	•CLIP, wire harness . . . . .	2
45	S.I.A.	•TERMINAL RING (M-8 stud) . . . . .	6
46	S.I.A.	•TERMINAL RING . . . . .	1
47	6003221	•CONNECTOR, two-way . . . . .	1
48	S.I.A.	•CONNECTOR, four-way . . . . .	1
49	6003224	•CONNECTOR, 16-way . . . . .	1
50	5937021	•CONNECTOR, molded . . . . .	1
51	6010127	•FUSE BOX COVER . . . . .	1
52	6010140B9	•FUSE BOX. . . . .	1
53	S.I.A.	•TRAILER LEADS, unterminated . . . . .	3

# 2001 HUMMER PARTS CATALOG

## ELECTRICAL 12-131

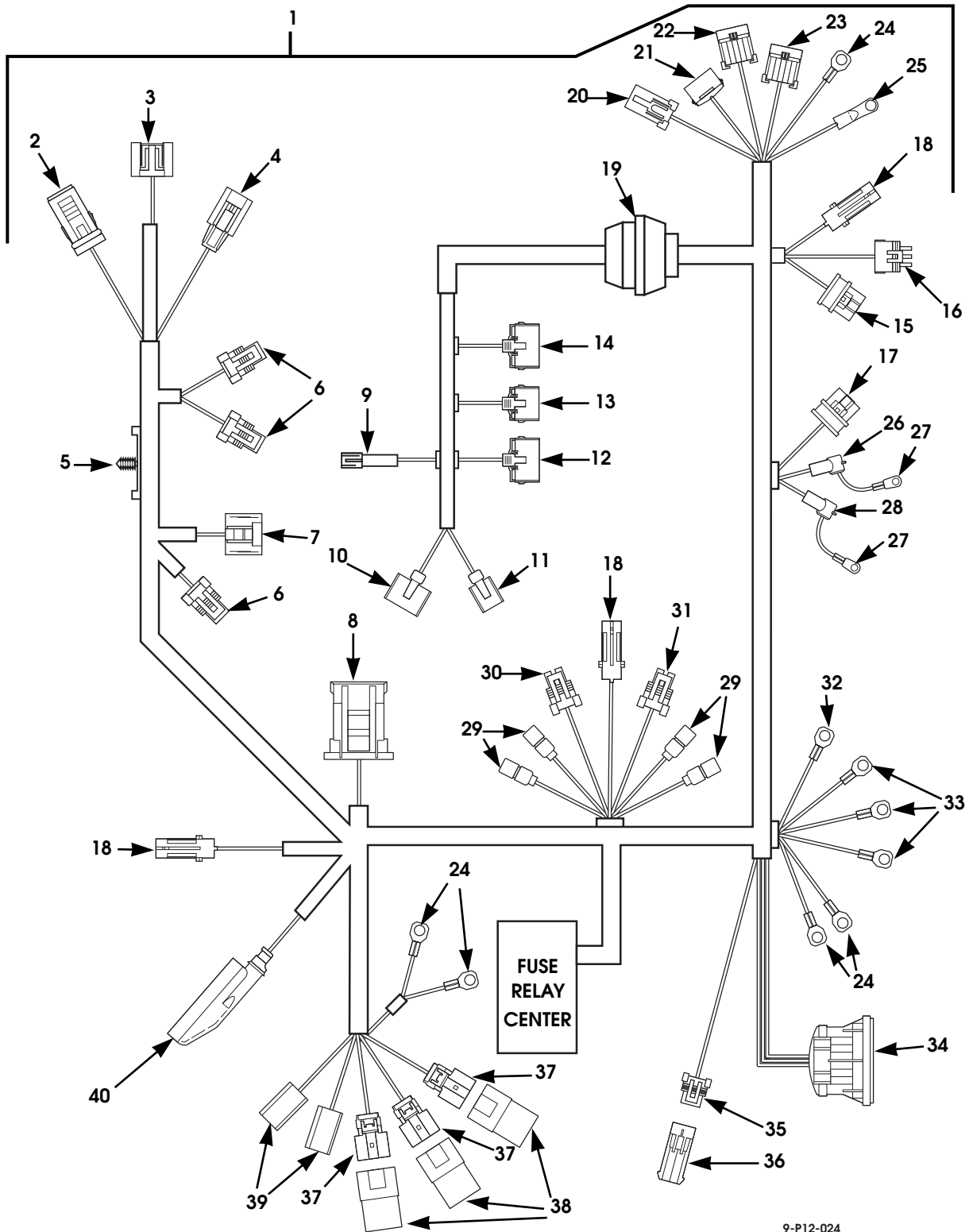

9-P12-024

Figure 12-52. Cowl Top Harness  
(Sheet 1 of 2).



# 2001 HUMMER PARTS CATALOG

## 12-132 ELECTRICAL

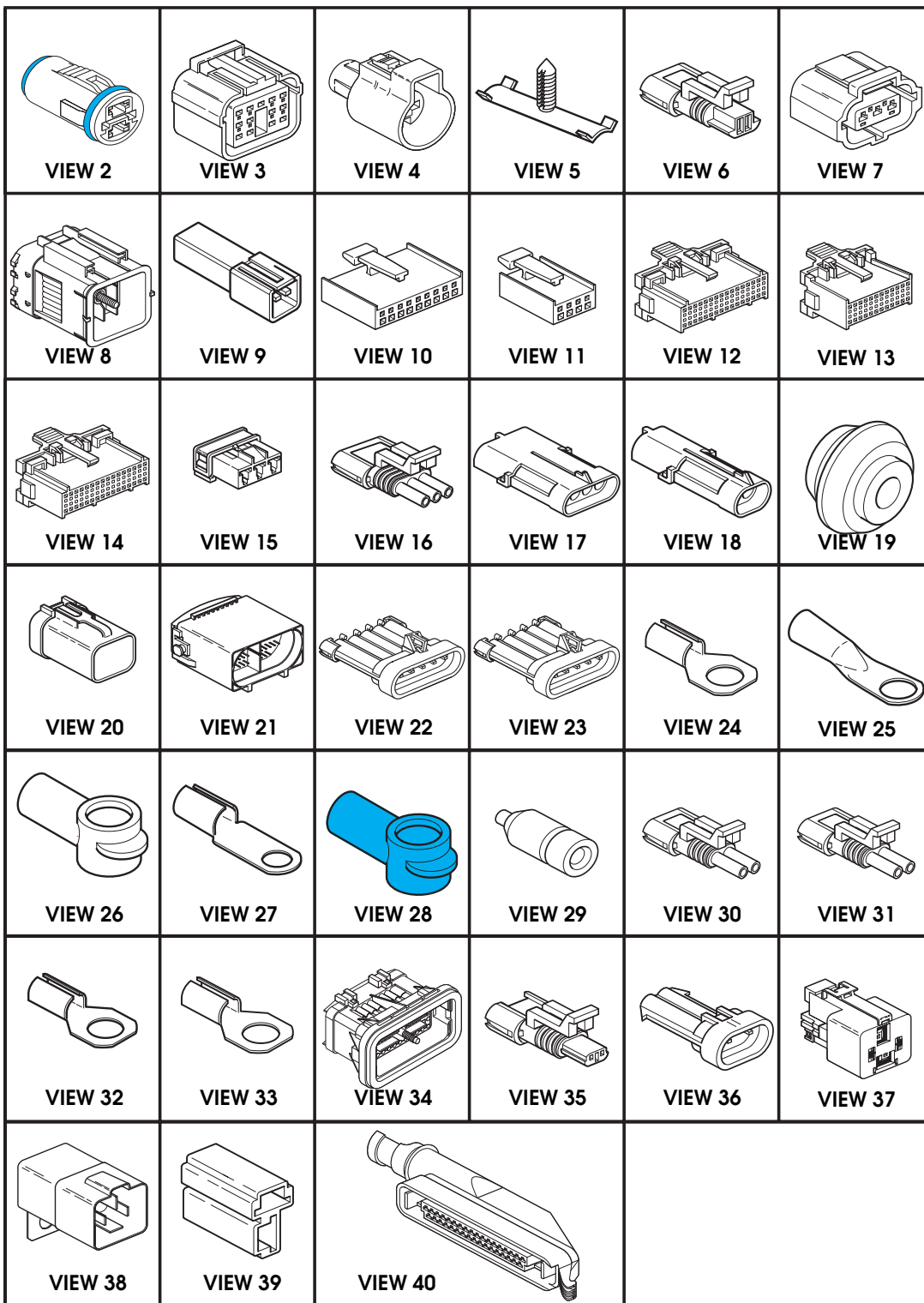

9-P12-024A

Figure 12-52. Cowl Top Harness  
(Sheet 2 of 2).

# 2001 HUMMER PARTS CATALOG

## ELECTRICAL 12-133

ITEM	PART NUMBER	DESCRIPTION	QTY
		<b>Figure 12-52. Cowl Top Harness</b>	
1	6011634	COWL TOP HARNESS ASSEMBLY . . . . .	1
2	S.I.A.	•CONNECTOR, 2-way . . . . .	1
3	S.I.A.	•CONNECTOR, 13-way . . . . .	1
4	S.I.A.	•CONNECTOR, ABS, ground. . . . .	1
5	S.I.A.	•RETAINER CLIP . . . . .	1
6	S.I.A.	•CONNECTOR, 2-way . . . . .	3
7	S.I.A.	•CONNECTOR, 3-way . . . . .	1
8	S.I.A.	•CONNECTOR, 42-way . . . . .	1
9	S.I.A.	•CONNECTOR, 2-way . . . . .	1
10	S.I.A.	•CONNECTOR, 9-way . . . . .	1
11	6004843	•CONNECTOR, 4-way . . . . .	1
12	6006953	•CONNECTOR, 32-way . . . . .	1
13	6006956	•CONNECTOR, 24-way . . . . .	1
14	6006955	•CONNECTOR, 32-way . . . . .	1
15	5937060	•CONNECTOR, 3-way . . . . .	1
16	5937082	•CONNECTOR, 3-way . . . . .	1
17	5939582	•CONNECTOR, 3-way . . . . .	1
18	5939099	•CONNECTOR, 2-way . . . . .	3
19	S.I.A.	•GROMMET, mold-on . . . . .	1
20	S.I.A.	•CONNECTOR, 12-way . . . . .	1
21	S.I.A.	•CONNECTOR, 40-way . . . . .	1
22	S.I.A.	•CONNECTOR, 10-way . . . . .	1
23	S.I.A.	•CONNECTOR, 10-way . . . . .	1
24	S.I.A.	•RING TERMINAL . . . . .	5
25	S.I.A.	•RING TERMINAL . . . . .	1
26	S.I.A.	•RUBBER BOOT, red . . . . .	1
27	S.I.A.	•CTI EYELET. . . . .	2
28	S.I.A.	•RUBBER BOOT, black . . . . .	1
29	MS27144-2	•CONNECTOR . . . . .	4
30	S.I.A.	•CONNECTOR, 2-way . . . . .	1
31	S.I.A.	•CONNECTOR, 2-way . . . . .	1
32	S.I.A.	•RING TERMINAL, (16 GA). . . . .	1
33	S.I.A.	•RING TERMINAL, (10 GA). . . . .	3
34	S.I.A.	•CONNECTOR, 76-way . . . . .	1
35	6008195	•CONNECTOR, 2-way . . . . .	1
36	6008196	•CONNECTOR, 2-way . . . . .	1
37	S.I.A.	•CONNECTOR, 4-way . . . . .	3
38	6010234	•RELAY, 80-amp . . . . .	3
39	S.I.A.	•CONNECTOR, 2-way . . . . .	2
40	S.I.A.	•CONNECTOR KIT . . . . .	1

# 2001 HUMMER PARTS CATALOG

## 12-134 ELECTRICAL

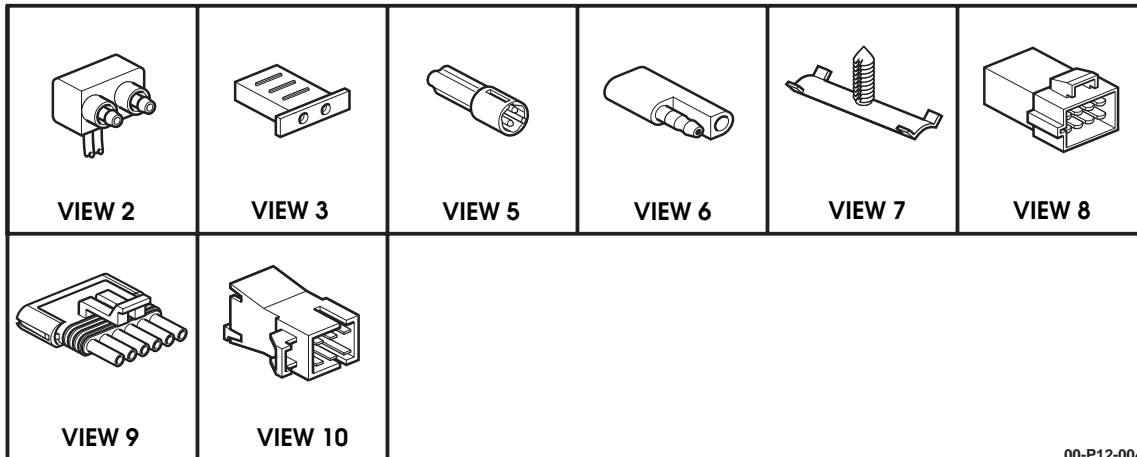
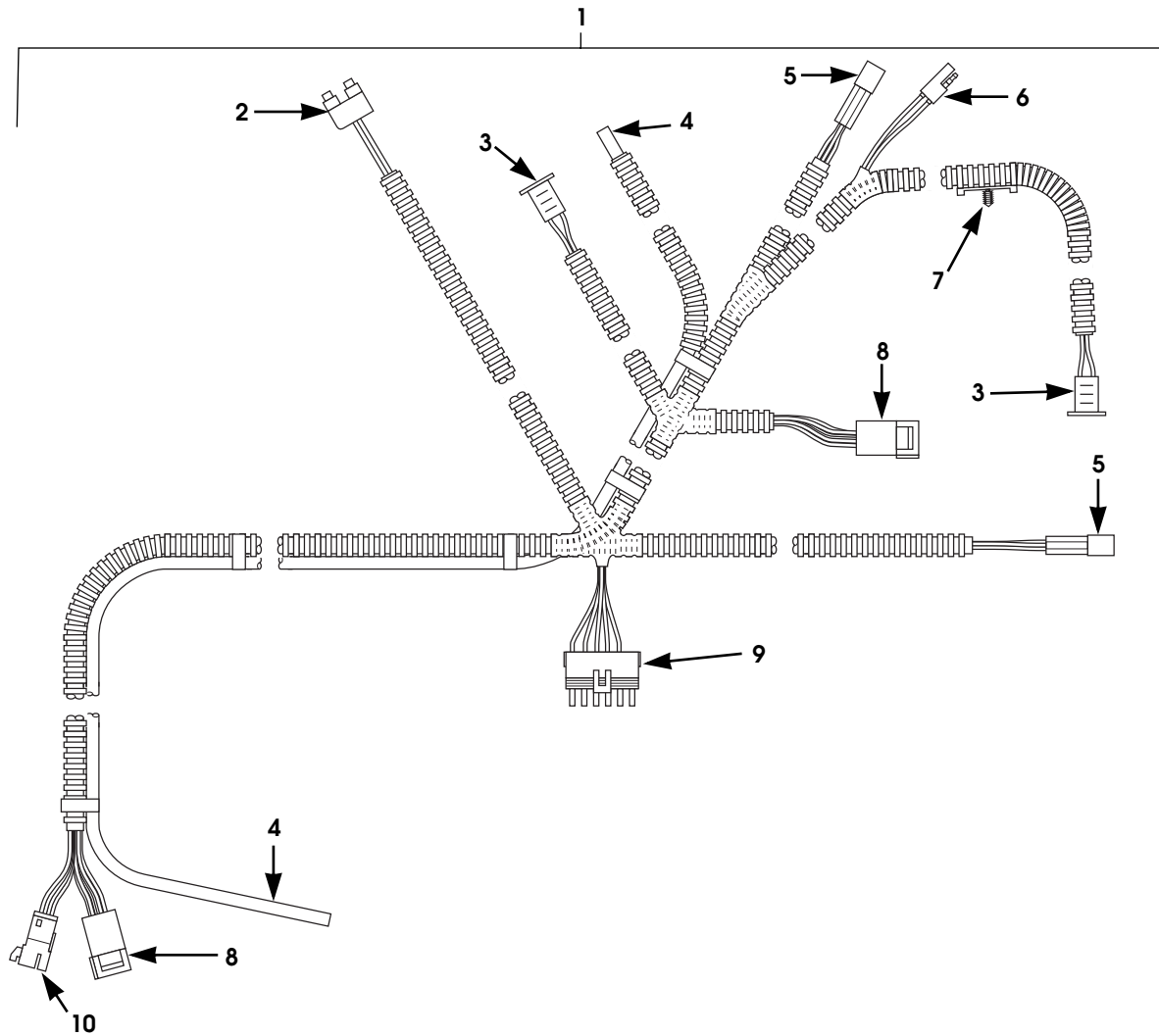

00-P12-004.1

Figure 12-53. Harness Assembly, Slant-Back Cargo Door, Model 91.

# 2001 HUMMER PARTS CATALOG

## ELECTRICAL 12-135

ITEM	PART NUMBER	DESCRIPTION	QTY
		<b>Figure 12-53.</b> <b>Harness Assembly, Slant-Back Cargo Door, Model 91.</b>	
1	6011057	HARNESS ASSEMBLY, slant-back door, jumper. . . . .	1
2	5937039	•CONNECTOR, 2-way mold on, to rear courtesy light	1
3	N/S	•CONNECTOR, 2-way mold on, to R.H. cargo light . . .	1
3	N/S	•CONNECTOR, 2-way mold on, to L.H. cargo light . . .	1
4	6011553	•HOSE, window washer fluid . . . . .	1
5	5939085	•CONNECTOR, 3-way to lift gate door jam switch . . .	1
5	5939085	•CONNECTOR, 3-way to rear door jam switch . . . . .	1
6	6000972	•CONNECTOR, 2-way mold on, to roof cargo lamp harness connector. . . . .	1
7	N/S	•RETAINER CLIP . . . . .	1
8	6008670	•CONNECTOR, 8-way . . . . .	2
9	5995714	•CONNECTOR, 6-way to rear door window and lock harness . . . . .	1
10	N/S	•CONNECTOR, 3-way to cross body harness. . . . .	1

# 2001 HUMMER PARTS CATALOG

## 12-136 ELECTRICAL

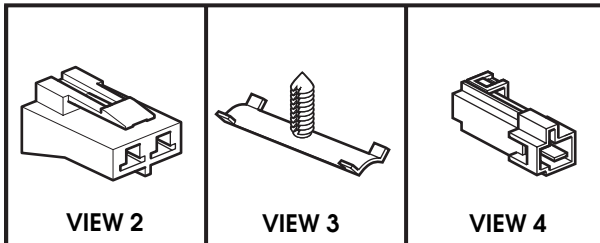
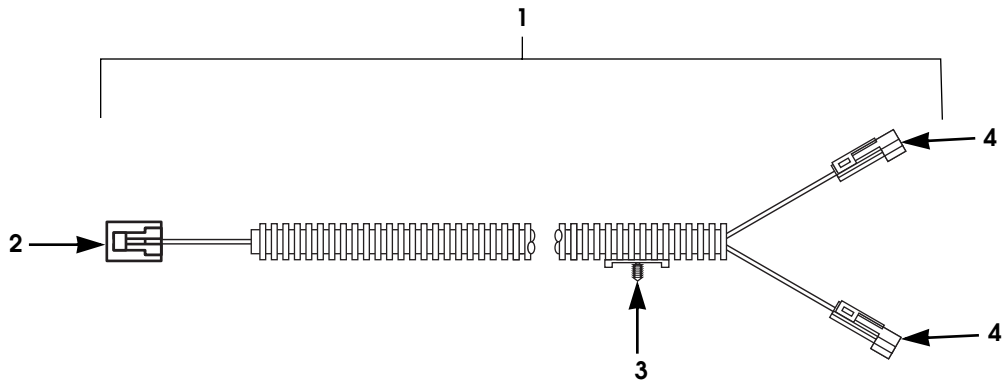

00-P12-002

Figure 12-54. Harness Assembly, Slant-Back Rear Defrost, Model 91.

# 2001 HUMMER PARTS CATALOG

## ELECTRICAL 12-137

ITEM	PART NUMBER	DESCRIPTION	QTY
		<b>Figure 12-54.</b> <b>Harness Assembly, Slant-Back Rear Defrost, Model 91.</b>	
1	6011056	HARNESS ASSEMBLY, slant-back defrost. . . . .	1
2	N/S	•CONNECTOR, 2-way . . . . .	1
3	N/S	•RETAINER CLIP . . . . .	1
4	N/S	•CONNECTOR, 1-way to R.H. rear window. . . . .	1
4	N/S	•CONNECTOR, 1-way to L.H. rear window. . . . .	1

# 2001 HUMMER PARTS CATALOG

## 12-138 ELECTRICAL

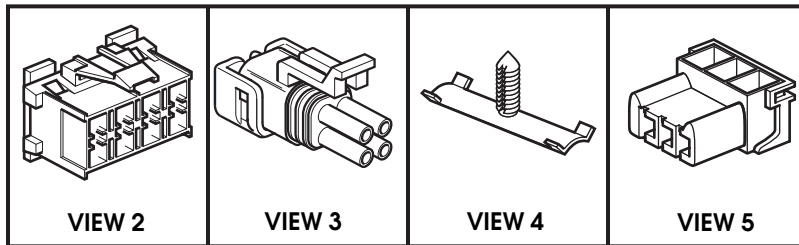
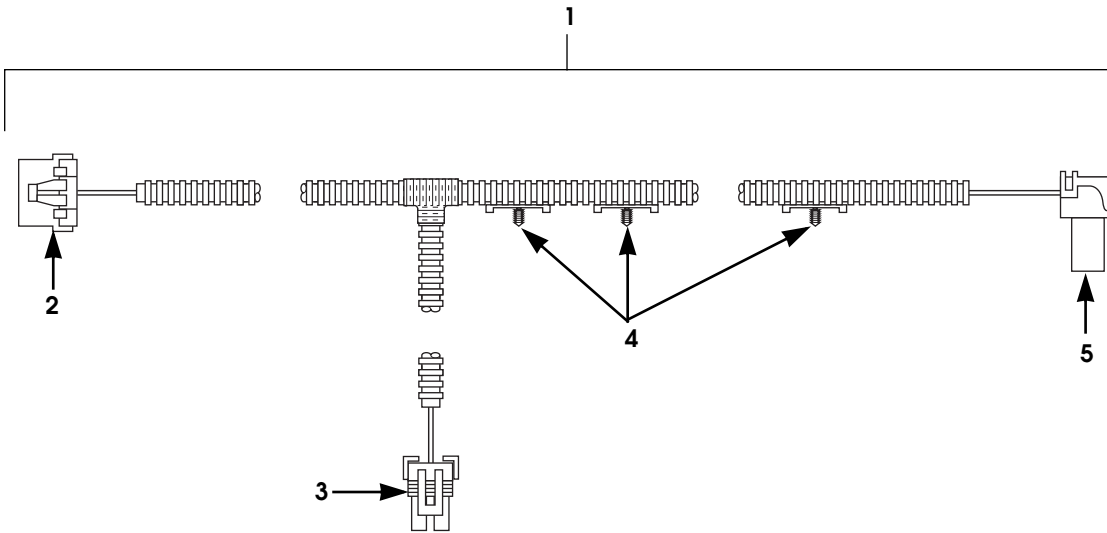

00-P12-003

Figure 12-55. Slant-Back Harness, Model 91.

# 2001 HUMMER PARTS CATALOG

## ELECTRICAL 12-139

ITEM	PART NUMBER	DESCRIPTION	QTY
		<b>Figure 12-55. Slant-Back Harness, Model 91.</b>	
1	6011051	HARNES ASSEMBLY, slant-back door .....	1
2	6002769	•CONNECTOR, 8-way to rear door and liftgate jumper	1
3	N/S	•CONNECTOR, 4-way to wiper motor .....	1
4	N/S	•RETAINER CLIP .....	3
5	N/S	•CONNECTOR, 3-way to lock actuator .....	1



# 2001 HUMMER PARTS CATALOG

## 12-140 ELECTRICAL

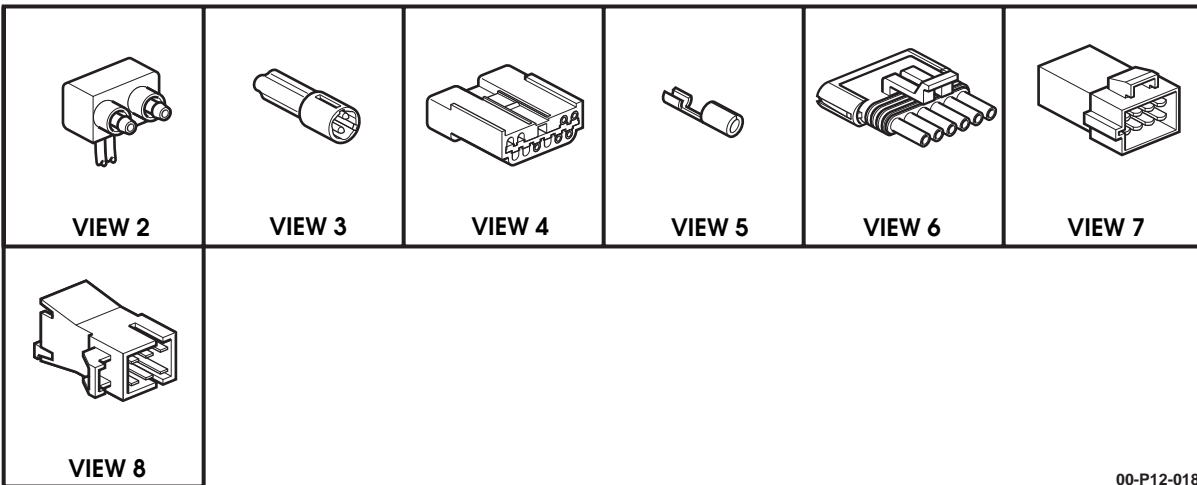
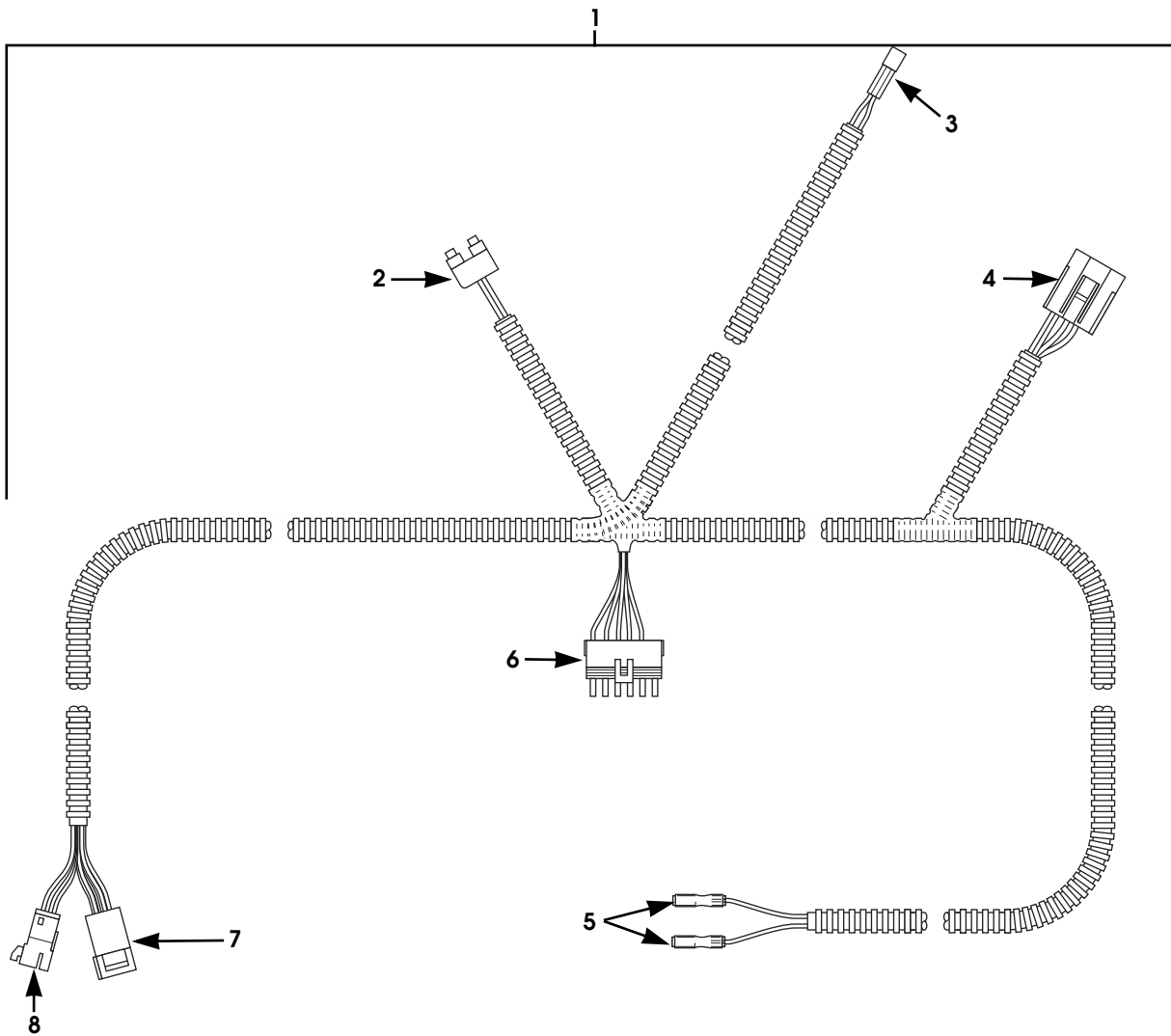

00-P12-018

Figure 12-56. Harness Assembly, Station Wagon Rear Door Jumper (RH Side).

# 2001 HUMMER PARTS CATALOG

## ELECTRICAL 12-141

ITEM	PART NUMBER	DESCRIPTION	QTY
		<b>Figure 12-56. Harness Assembly, Station Wagon Rear Door Jumper (RH Side).</b>	
1	6010117	HARNESS ASSEMBLY, rear door jumper . . . . .	1
2	5937039	•CONNECTOR, 2-way mold-on, to rear courtesy light	1
3	5939085	•CONNECTOR, 3-way, to rear door jamb switch . . . . .	1
4	6009107	•CONNECTOR, 10-way, to rear door lock module . . .	1
5	6009730	•TERMINAL, female, to rear vertical door contacts. . .	2
6	5995714	•CONNECTOR, 6-way, to rear door window and locks harness . . . . .	1
7	6008670	•CONNECTOR, 8-way, to cross-body harness . . . . .	1
8	6010129	•CONNECTOR, 6-way, to cross-body harness . . . . .	1

# 2001 HUMMER PARTS CATALOG

## 12-142 ELECTRICAL

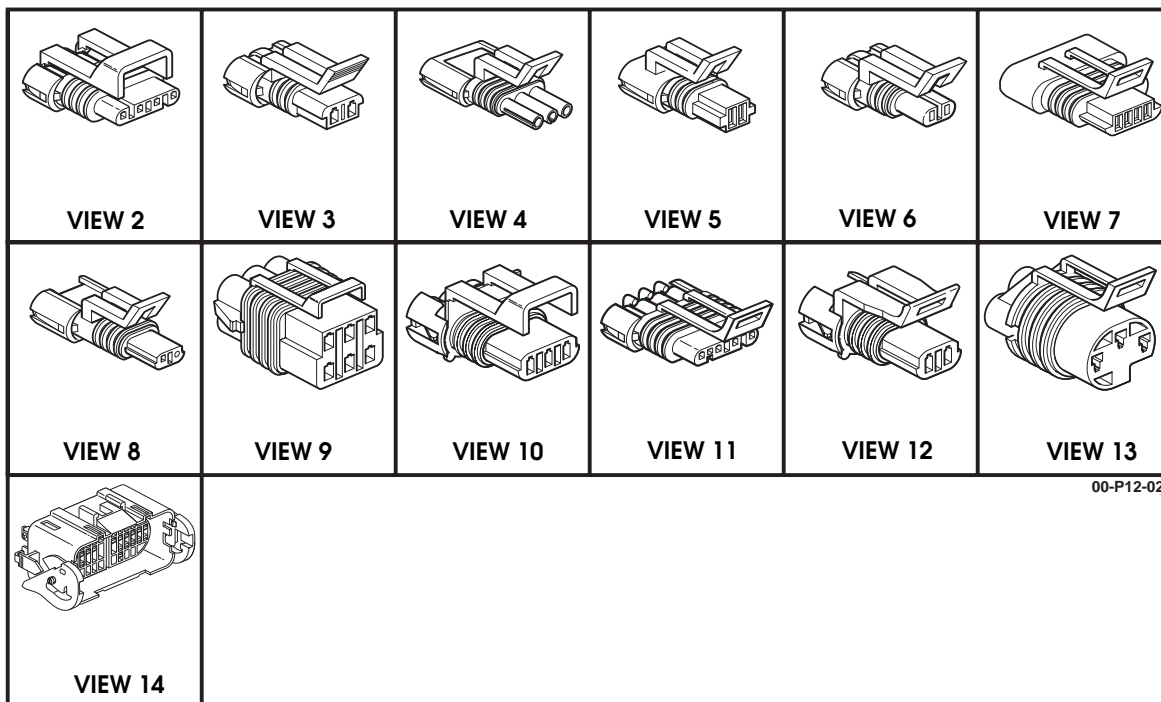
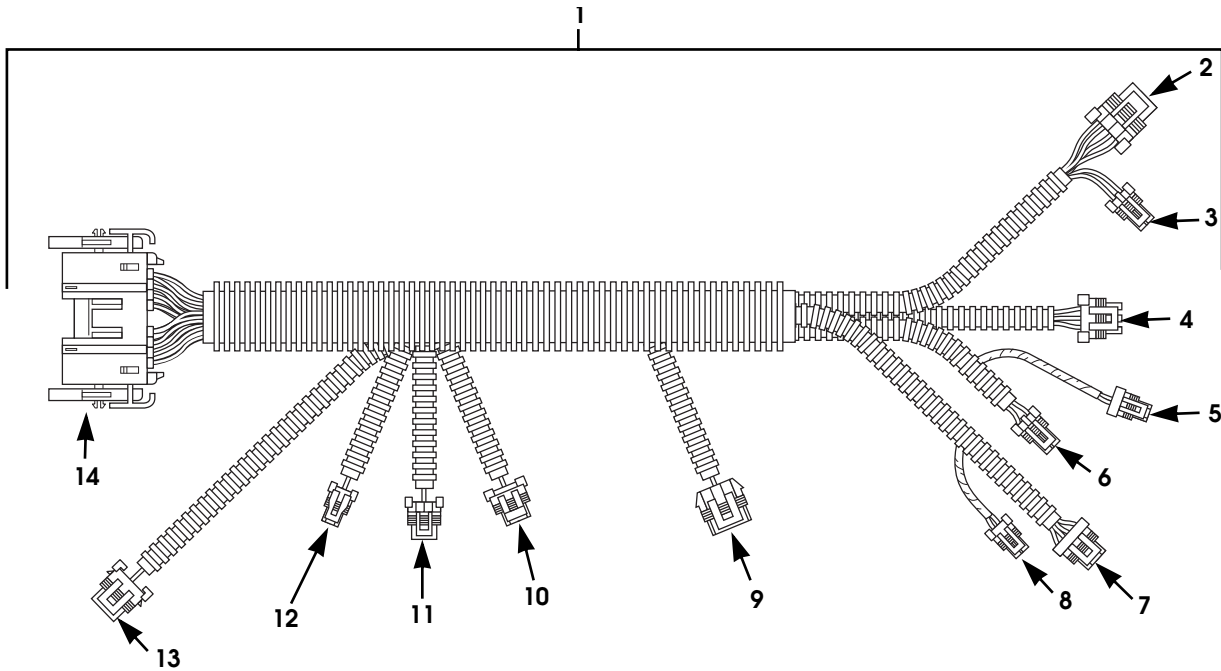

Figure 12-57. Engine Harness Assembly, GM.

# 2001 HUMMER PARTS CATALOG

## ELECTRICAL 12-143

ITEM	PART NUMBER	DESCRIPTION	QTY
		<b>Figure 12-57. Engine Harness Assembly, GM.</b>	
1	5745363	HARNESS ASSEMBLY, engine . . . . .	1
2	S.I.A.	•CONNECTOR, 4-way . . . . .	1
3	S.I.A.	•CONNECTOR, 2-way . . . . .	1
4	S.I.A.	•CONNECTOR, 3-way . . . . .	1
5	S.I.A.	•CONNECTOR, 2-way . . . . .	1
6	S.I.A.	•CONNECTOR, 2-way . . . . .	1
7	S.I.A.	•CONNECTOR, 4-way . . . . .	1
8	S.I.A.	•CONNECTOR, 2-way . . . . .	1
9	S.I.A.	•CONNECTOR, 6-way . . . . .	1
10	S.I.A.	•CONNECTOR, 3-way . . . . .	1
11	S.I.A.	•CONNECTOR, 4-way . . . . .	1
12	S.I.A.	•CONNECTOR, 2-way . . . . .	1
13	S.I.A.	•CONNECTOR, 3-way . . . . .	1
14	S.I.A.	•CONNECTOR, 40-way . . . . .	1
		NOTE 1: ENGINE HARNESS ASSEMBLY P/N 5745363 COMES WITH ENGINE.	

# 2001 HUMMER PARTS CATALOG

## 12-144 ELECTRICAL

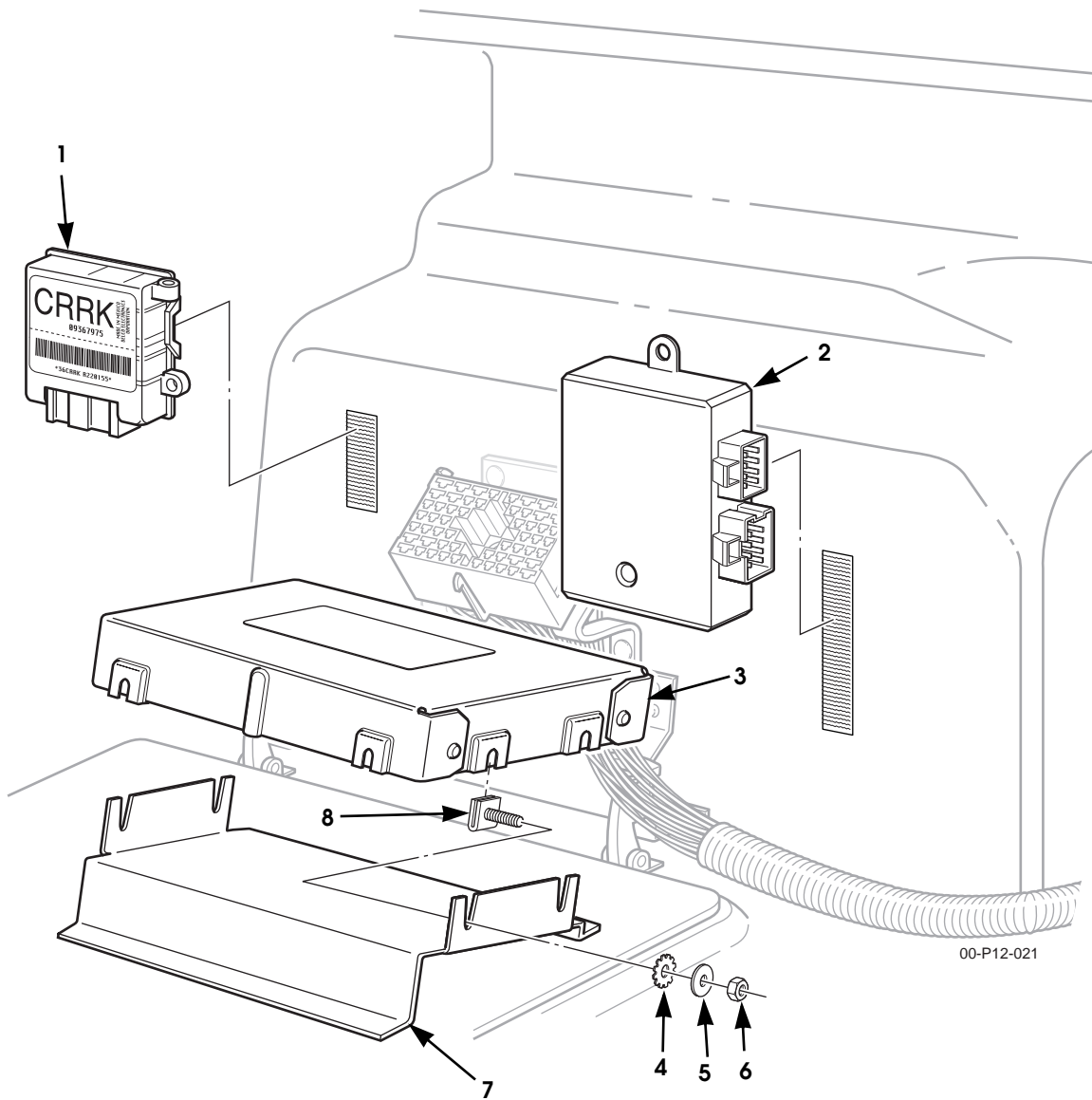

Figure 12-58. PCM and Digital Ratio Adapter.

# 2001 HUMMER PARTS CATALOG

## ELECTRICAL 12-145

ITEM	PART NUMBER	DESCRIPTION	QTY
		<b>Figure 12-58. PCM and Digital Ratio Adapter.</b>	
1	6009716	ADAPTER, digital ratio, 2.56:1 axle ratio . . . . .	1
1	6009717	ADAPTER, digital ratio, 3.08:1 axle ratio . . . . .	1
2	6010412	RECEIVER MODULE, keyless entry . . . . .	1
3	6010811	MODULE, powertrain control, domestic . . . . .	1
3	6010812	MODULE, powertrain control, export . . . . .	1
4	B18245B05	NUT . . . . .	4
5	9416128	WASHER, flat . . . . .	4
6	MS45904-60	LOCKWASHER, external-tooth . . . . .	4
7	6010432B9	BRACKET, PCM mounting . . . . .	1
8	6003831	CLIP AND STUD ASSEMBLY . . . . .	4

# 2001 HUMMER PARTS CATALOG

## 12-146 ELECTRICAL

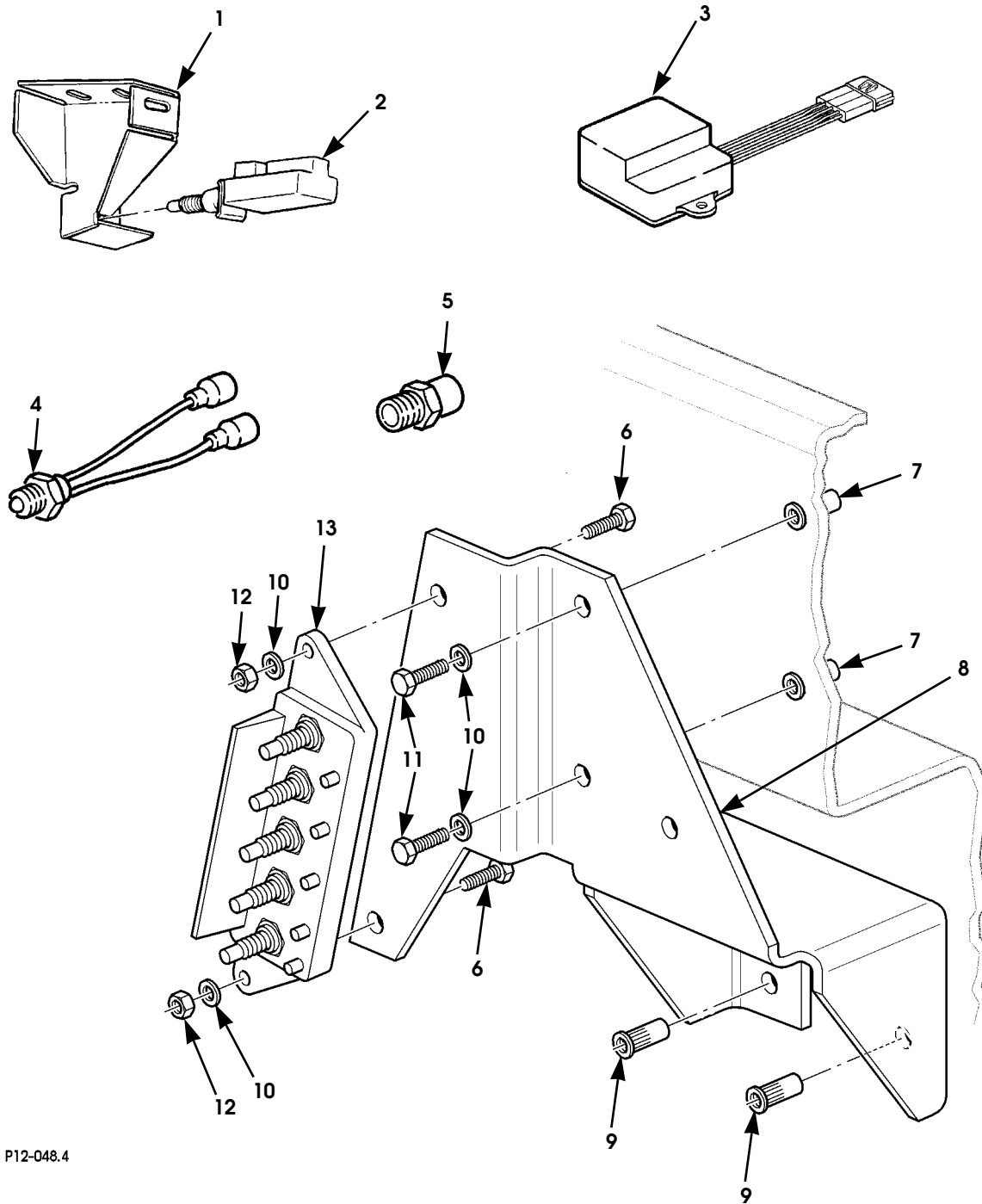

P12-048.4

Figure 12-59. Miscellaneous Electrical Items.

# 2001 HUMMER PARTS CATALOG

## ELECTRICAL 12-147

ITEM	PART NUMBER	DESCRIPTION	QTY
		<b>Figure 12-59. Miscellaneous Electrical Items.</b>	
1	6002810	BRAKE LIGHT SWITCH BRACKET .....	1
2	6002811	BRAKE LIGHT/CRUISE SWITCH .....	1
3	6002625	DAYTIME RUNNING LIGHT MODULE (Canada Only) ..	1
4	12356704	PARKING BRAKE SWITCH .....	1
5	5938686	TRANSFER LOCK SWITCH .....	1
6	N/S	SCREW, 1/4 - 20 x 3/4. ....	2
7	5937842	NUT INSERT .....	3
8	6010328	BRACKET ASSEMBLY, junction block & connector mounting. ....	1
9	5939712	•NUT INSERT .....	2
10	N/S	FLAT WASHER, 1/4. ....	5
11	N/S	BOLT, 1/4 - 20 x 5/8. ....	3
12	N/S	NUT, 1/4 - 20 .....	2
13	6007329	JUNCTION BLOCK .....	1



# 2001 HUMMER PARTS CATALOG

## 12-148 ELECTRICAL

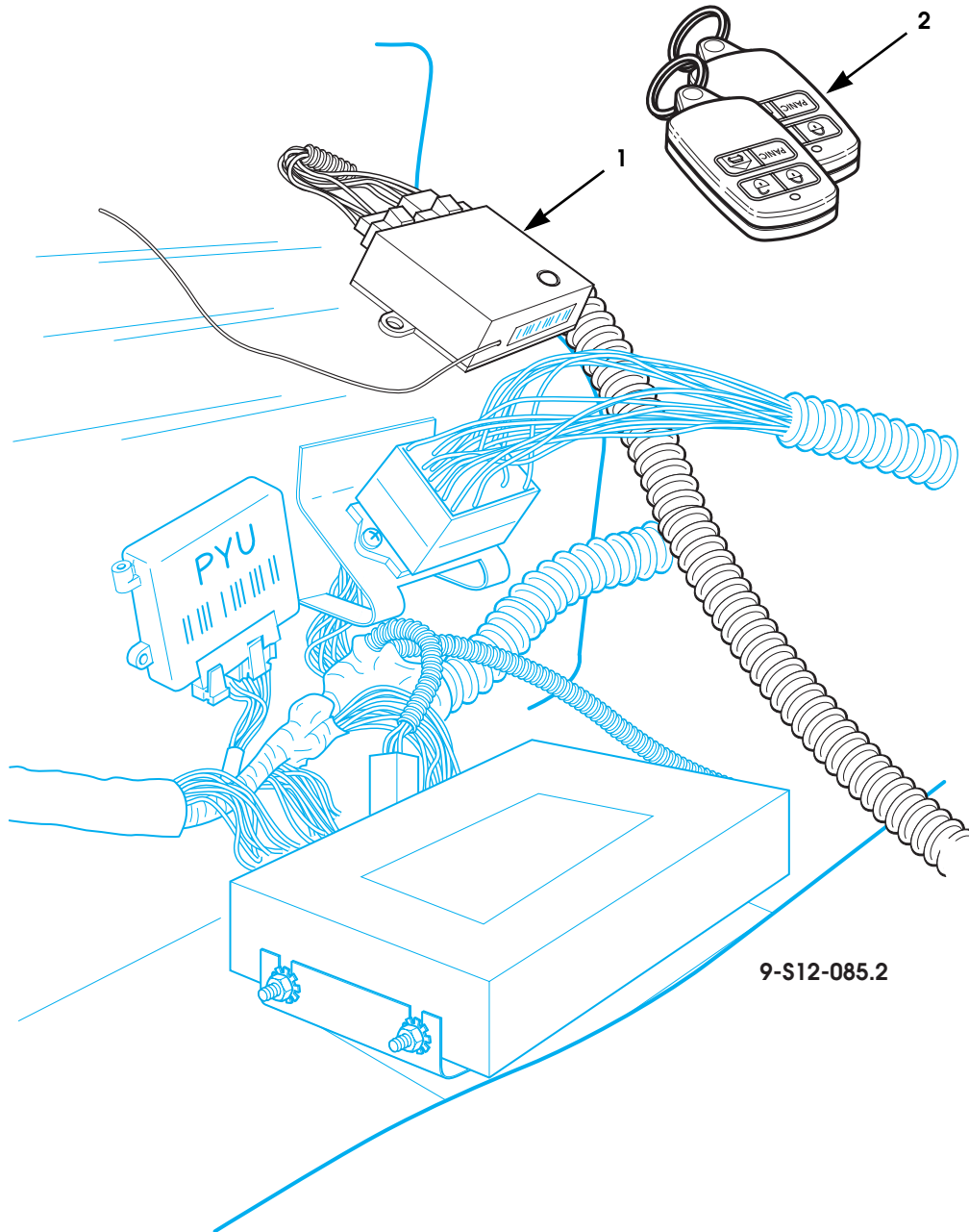

Figure 12-60. Remote Entry Transmitter and Receiver

# 2001 HUMMER PARTS CATALOG

## ELECTRICAL 12-149

ITEM	PART NUMBER	DESCRIPTION	QTY
1	6010412	<p><b>Figure 12-60.</b>  <b>Remote Entry Transmitter and Receiver</b></p> <p>RECEIVER MODULE, remote entry . . . . .</p>	1
2	6010411	<p>TRANSMITTER, four-button, remote entry, SEE NOTE 1 . .</p> <p>            NOTE 1: THE FOUR-BUTTON TRANSMITTER IS THE REPLACEMENT FOR THE FACTORY-SUPPLIED THREE-BUTTON TRANSMITTER. SEE REMOTE ENTRY KIT, P/N 5745076, IN ACCESSORIES, CHAPTER 13. THE THREE BUTTON TRANSMITTER IS NOT AVAILABLE.</p>	2



# 2001 HUMMER PARTS CATALOG

## ACCESSORIES 13-1

### Section 13 ACCESSORIES

TITLE	PAGE NUMBER
Air Filter Restriction Gauge Kit . . . . .	13-62
Auxiliary Air Hose Kit . . . . .	13-46
Bedliner Kit . . . . .	13-118
Bike Rack Kit . . . . .	13-112
Brushguard Kit and Mounting Hardware . . . . .	13-12
Brushguard Kit, Heavy Duty Accessory Frontal-Coverage . . . . .	13-14
Brushguard Kit, Heavy Duty Accessory Wrap-Around . . . . .	13-16
Bumper (Front with Brushguard and without Winch) Cover Kit, Polished or Brushed Stainless Steel . . . . .	13-102
Bumper (Front with Winch) Cover Kit, Polished or Brushed Stainless Steel . . . . .	13-100
Bumper (Rear) Cover, Polished or Brushed Stainless Steel . . . . .	13-104
Cargo Area Liner, Station Wagon . . . . .	13-54
CD Changer and Remote Control . . . . .	13-84
Dash Trim Appliqué Kit, 1993 - 2000 . . . . .	13-86
Door Handle and Bezel Covers, Polished and Brushed Stainless Steel . . . . .	13-116
Driveline Protection and Mounting Hardware . . . . .	13-28
Driveline Protection Skid Plates . . . . .	13-30
Dual Oil Filter Kit . . . . .	13-94
Electric Seat Heater Kit . . . . .	13-88
Floor Mats . . . . .	13-56
Grille (Front) Cover, Polished or Brushed Stainless Steel . . . . .	13-108
Grille (Upper) Cover, Polished or Brushed Stainless Steel . . . . .	13-106
Hourmeter Kit . . . . .	13-70
Leather Upholstery . . . . .	13-60
Off-Road Accessory Kit, 4-Door Hard Top and 4-Door Soft Top, Models 83 and 90 . . . . .	13-92
Off-Road Accessory Kit, Station Wagon, Model 84 . . . . .	13-90
Off-Road Light Kit . . . . .	13-80
Pioneer Tool Kit . . . . .	13-22
Radio Noise Suppression Filter Kit . . . . .	13-72
Rear Defroster . . . . .	13-48
Reflective Triangle Warning Device, Jack Assembly, and Mounting Hardware . . . . .	13-18
Remote Entry Kits . . . . .	13-34
Rocker Panel Guard Accessory Kit . . . . .	13-32
Roof Rack Kit, Aluminum, Round Tube . . . . .	13-124
Roof Rack Kit, Side Load . . . . .	13-114
Roof Rack Kit, Steel, Square Tube . . . . .	13-122
Running Board Kit . . . . .	13-42
Seat Covers . . . . .	13-58
Seat, Auxiliary . . . . .	13-50
Side Step Bars Kit . . . . .	13-44
Ski Rack Kit . . . . .	13-120
Skid Plate Cover, Polished Stainless Steel . . . . .	13-110
Slant-Back (Soft) Kit (Four-Door Soft Top) . . . . .	13-74

# 2001 HUMMER PARTS CATALOG

## 13-2 ACCESSORIES

TITLE	PAGE NUMBER
Soft Square Back Kit, Model 90 . . . . .	13-76
Spare Tire Carrier Kit, Swing-Away (Steel Wheels Only) . . . . .	13-24
Spare Tire Carrier, Bed-Mounted (Steel Wheels Only) . . . . .	13-26
Tire (Tubeless) Repair Kit, External . . . . .	13-66
Tire (Tubeless) Repair Kit, Internal . . . . .	13-68
Tire Chains . . . . .	13-98
Tire Repair Accessory Kit, External . . . . .	13-96
Tonneau Cover 4-Door Hardtop . . . . .	13-52
Tow Ball Assembly . . . . .	13-10
Traveler's Survival Kit . . . . .	13-64
Universal Roof Mounting Rack Kit . . . . .	13-40
Utility Step . . . . .	13-20
Wheel and Tire Assembly, SpaceSaver Spare . . . . .	13-36
Wheel Cover Kit, Stainless Steel . . . . .	13-82
Wheel, Tire, and Runflat Assembly, One-Piece Aluminum Rim, 16.5" (Optional) . . . . .	13-38
Winch Accessory Kit . . . . .	13-8
Winch Assembly, Mounting Hardware, and Related Parts (Winch Kit) . . . . .	13-3
Winch Assembly . . . . .	13-6
Winch Roller Fairlead . . . . .	13-78

# 2001 HUMMER PARTS CATALOG

## ACCESSORIES 13-3

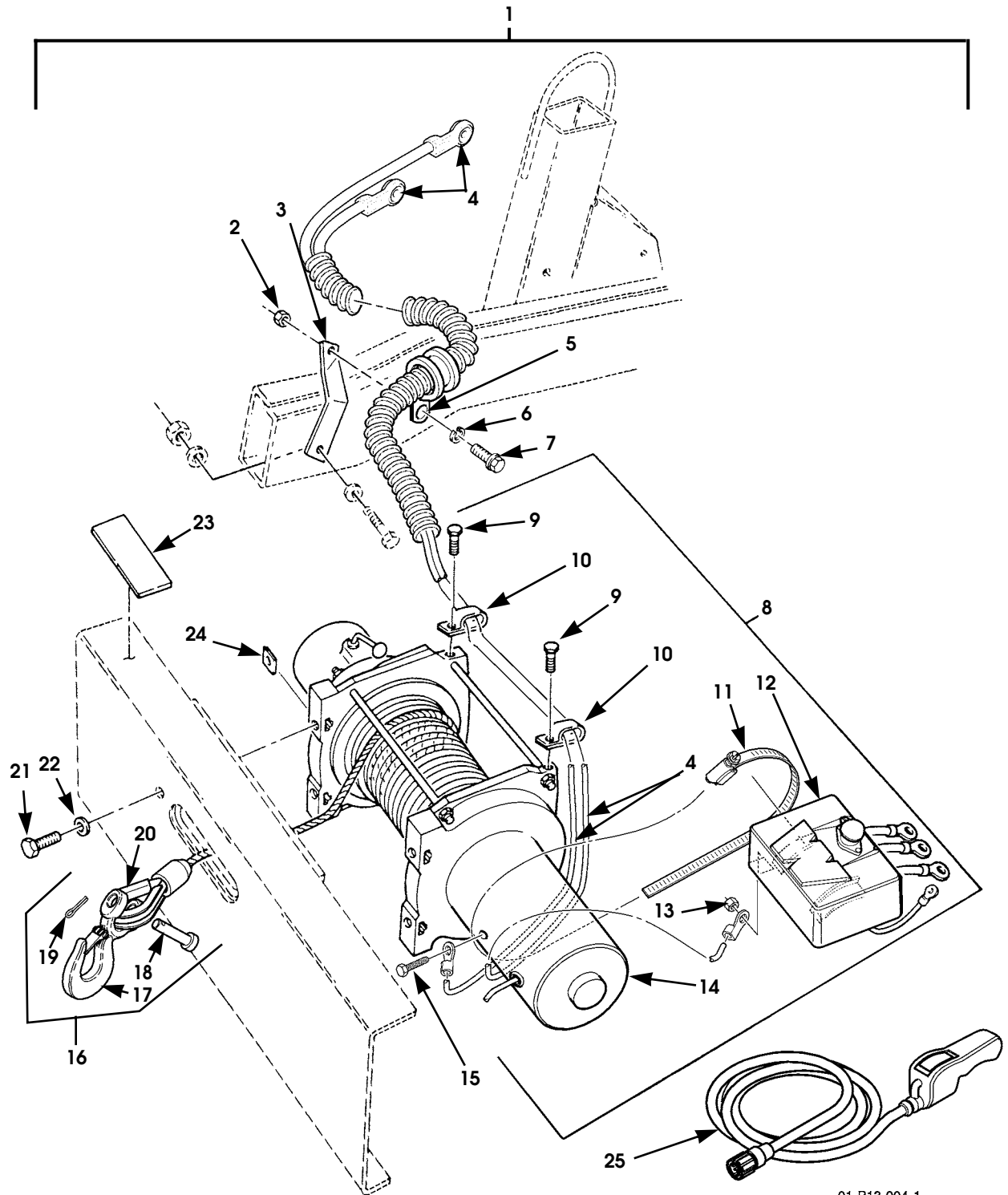

01-P13-004.1

Figure 13-1. Winch Assembly, Mounting Hardware, and Related Parts (Winch Kit)  
Sheet 1 of 2.

# 2001 HUMMER PARTS CATALOG

## 13-4 ACCESSORIES

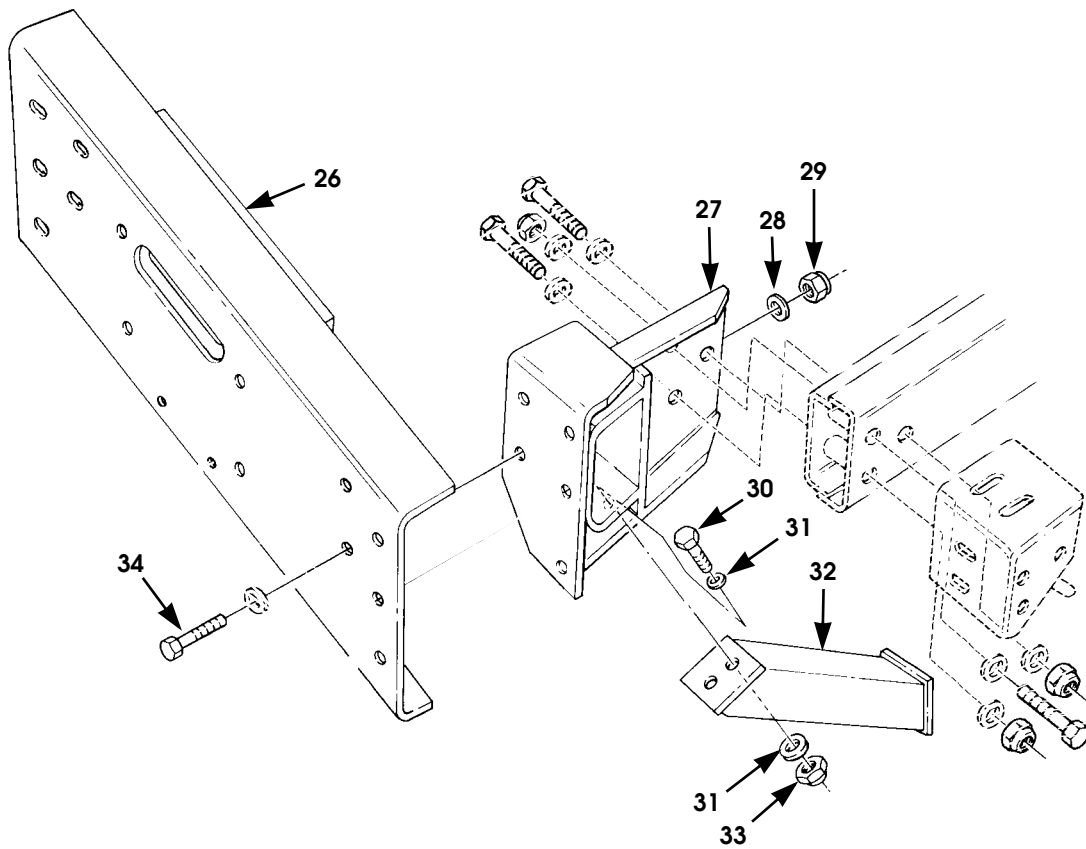

P09-009.2

Figure 13-1. Winch Assembly, Mounting Hardware, and Related Parts (Winch Kit)  
Sheet 2 of 2.

# 2001 HUMMER PARTS CATALOG

## ACCESSORIES 13-5

ITEM	PART NUMBER	DESCRIPTION	QTY
		<b>Figure 13-1. Winch Assembly, Mounting Hardware, and Related Parts (Winch Kit).</b>	
1	5745286	KIT, winch, 12V, 12000-lb capacity, SEE NOTES 1, 2, and 3.	1
2	S.I.K.	•NUT, clamp, 1/4 - 2,0 Gr8 . . . . .	1
3	12338481	•BRACKET, clamp . . . . .	1
4	5744290	•CABLE ASSEMBLY, winch-to-battery . . . . .	1
5	7385182	•CLAMP, positive and ground cables. . . . .	1
6	S.I.K.	•LOCKWASHER, med, 1/4, ZN, clamp . . . . .	1
7	S.I.K.	•SCREW, 1/4 - 20 x 3/4, ZN, clamp . . . . .	1
8	6011149	•WINCH ASSEMBLY . . . . .	1
9	S.I.A.	••SCREW, clamp. . . . .	2
10	MS21334-28	••CLAMP, positive and ground cables . . . . .	2
11	5741028	••CLAMP, winch motor-to-cover assembly, . . . . .	2
12	5745269	••CONTROL PACK . . . . .	1
13	S.I.A.	••NUT, winch cable-to-motor stud . . . . .	1
14	S.I.A.	••WINCH . . . . .	1
15	S.I.A.	••SCREW, winch cable-to-motor . . . . .	1
16	5744739	•HOOK ASSEMBLY . . . . .	1
17	S.I.A.	••HOOK, winch. . . . .	1
18	S.I.A.	••CLEVIS PIN, winch hook . . . . .	1
19	S.I.A.	••COTTER PIN, 1/8 x 1 1/4 . . . . .	1
20	5742974	•WIRE ROPE, 75 feet long. . . . .	1
21	5741152	•BOLT, winch, M12 - 1.75 x 35. . . . .	4
22	S.I.K.	•WASHER, M12. . . . .	4
23	6000236	•DECAL, winch . . . . .	1
24	MS27040-13	•NUT, winch . . . . .	4
25	5745267	•REMOTE CONTROLLER, winch. . . . .	1
26	5935666B5	•BUMPER, front . . . . .	1
27	12342388B5	•FRAME EXTENSION, front bumper, R.H. . . . .	1
27	12342387B5	•FRAME EXTENSION, front bumper, L.H. . . . .	1
28	S.I.K.	•WASHER, flat, hard, 1/2, type B. . . . .	18
29	S.I.K.	•LOCKNUT, 1/2 - 13, front bumper . . . . .	8
30	S.I.K.	•BOLT, 5/8 - 16 x 1, brace assembly . . . . .	4
31	S.I.K.	•WASHER, flat, 3/8, brace assembly . . . . .	8
32	12342389	•BRACE ASSEMBLY, L.H. . . . .	1
32	12342390	•BRACE ASSEMBLY, R.H. . . . .	1
33	S.I.K.	•NUT, 3/8 - 16, brace assembly . . . . .	4
34	S.I.K.	•BOLT, 1/2 - 13 x 1 1/2, frame extension. . . . .	6
		NOTE 1: MUST ALSO ORDER SKID PLATE, P/N 5935669, FOR VEHICLES WITH UNDERBODY PROTECTION.	
		NOTE 2: TO KEEP VEHICLE WARRANTY IN EFFECT, UPGRADED HEAVY DUTY FRONT SPRINGS MUST BE USED ON VEHICLES EQUIPPED WITH WINCH. SEE SERVICE INFORMATION BULLETIN 98-13-06.	
		NOTE 3: FOR MOUNTING HARDWARE, REFER TO FRONT BUMPER AND LIFTING SHACKLE (WINCH KIT) IN SECTION 9.	



# 2001 HUMMER PARTS CATALOG

## 13-6 ACCESSORIES

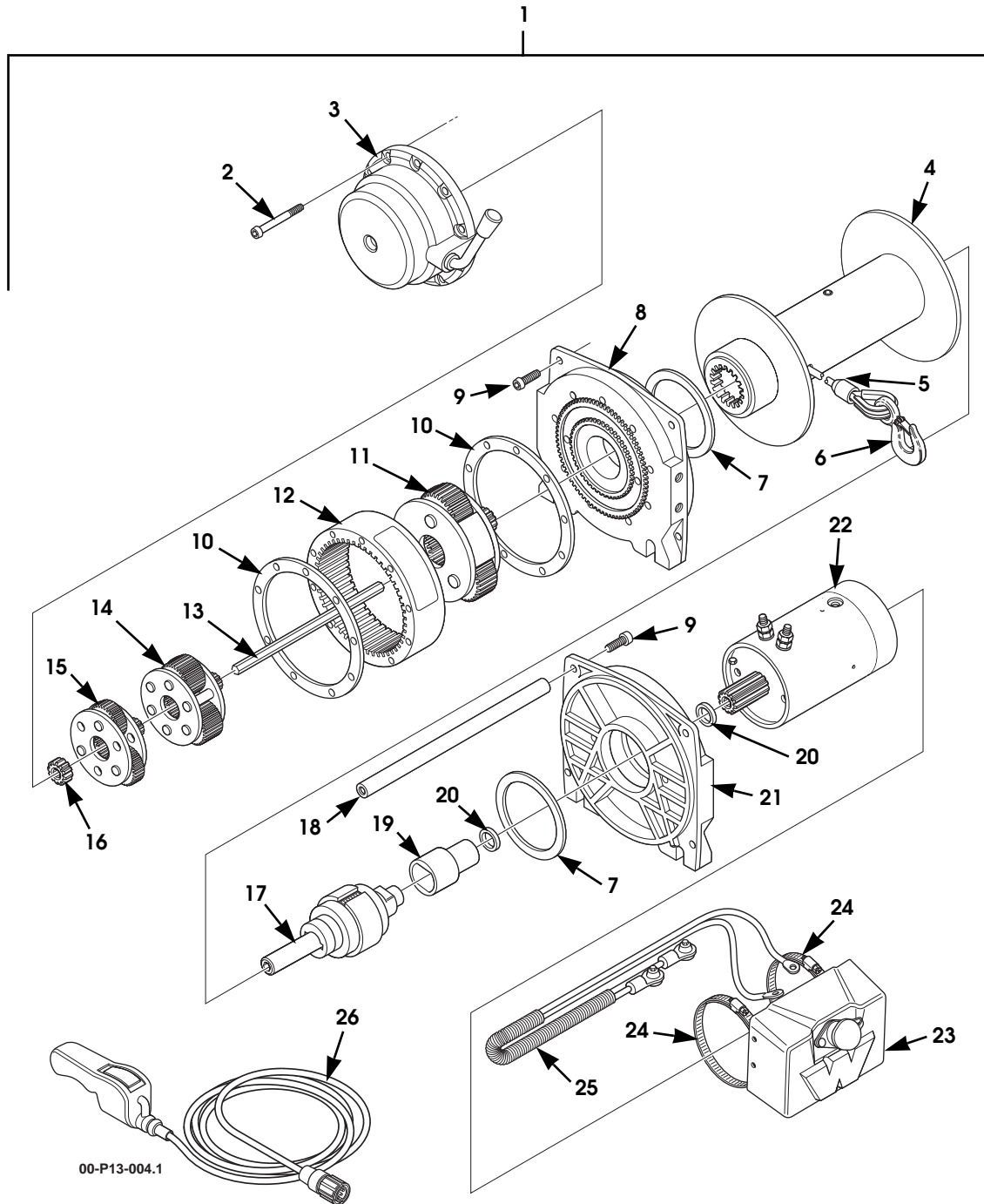

Figure 13-2. Winch Assembly.

# 2001 HUMMER PARTS CATALOG

## ACCESSORIES 13-7

ITEM	PART NUMBER	DESCRIPTION	QTY
		<b>Figure 13-2. Winch Assembly.</b>	
1	6011149	WINCH ASSEMBLY .....	1
2	5742884	•CAPSCREW, allen head, 1/4 - 20 x 3 .....	10
3	5745266	•GEAR HOUSING ASSEMBLY .....	1
4	5745261	•DRUM ASSEMBLY .....	1
5	5742974	•WIRE ROPE, 7/16-inch DIA. x 64.5-feet long .....	1
6	5744739	•HOOK AND CABLE .....	1
7	5714481	•THRUST WASHER .....	2
8	5745262	•DRUM SUPPORT, gear end .....	1
9	5745259	•CAPSCREW, allenhead, 3/8 - 16 x 1 .....	6
10	5745263	•GASKET .....	2
11	5714484	•CARRIER ASSEMBLY, stage 3 .....	1
12	5745264	•RING GEAR, output stage .....	1
13	5714498	•DRIVE SHAFT .....	1
14	5745265	•CARRIER GEAR, stage 2 .....	1
15	5742886	•CARRIER GEAR, stage 1 .....	1
16	5742888	•SUN GEAR .....	1
17	5714499	•BRAKE ASSEMBLY .....	1
18	5745260	•TIE ROD .....	3
19	5714478	•BRAKE DRIVER .....	1
20	5742882	•SPACER .....	2
21	5745258	•DRUM SUPPORT, motor end .....	1
22	5745257	•MOTOR ASSEMBLY, winch .....	1
23	5745269	•CONTROL PACK ASSEMBLY .....	1
24	5741028	•CLAMP .....	2
25	5745268	•CABLE ASSEMBLY, battery .....	1
26	5745267	•REMOTE CONTROLLER .....	1

# 2001 HUMMER PARTS CATALOG

## 13-8 ACCESSORIES

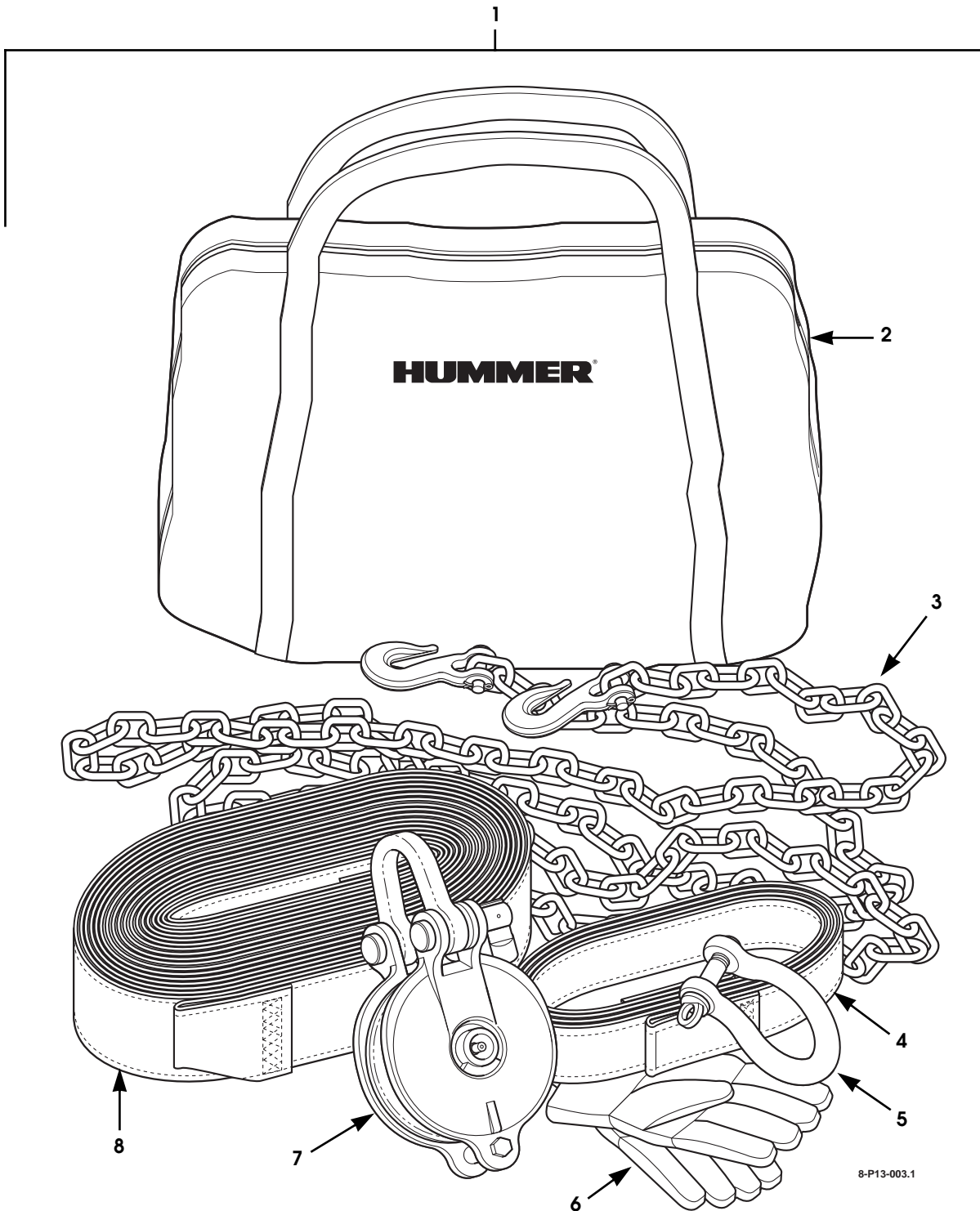

8-P13-003.1

Figure 13-3. Winch Accessory Kit.

# 2001 HUMMER PARTS CATALOG

## ACCESSORIES 13-9

ITEM	PART NUMBER	DESCRIPTION	QTY
		<b>Figure 13-3. Winch Accessory Kit.</b>	
1	5745019	KIT, winch accessory . . . . .	1
2	S.I.K.	•BAG, camouflage . . . . .	1
3	S.I.K.	•CHAIN . . . . .	1
4	S.I.K.	•TRUNK PROTECTOR, 2-inch . . . . .	1
5	S.I.K.	•SHACKLE 3/4-inch . . . . .	1
6	S.I.K.	•GLOVES . . . . .	1 pair
7	S.I.K.	•SNATCH BLOCK . . . . .	1
8	5744881	•STRAP, 3-inch 30 feet . . . . .	1

# 2001 HUMMER PARTS CATALOG

## 13-10 ACCESSORIES

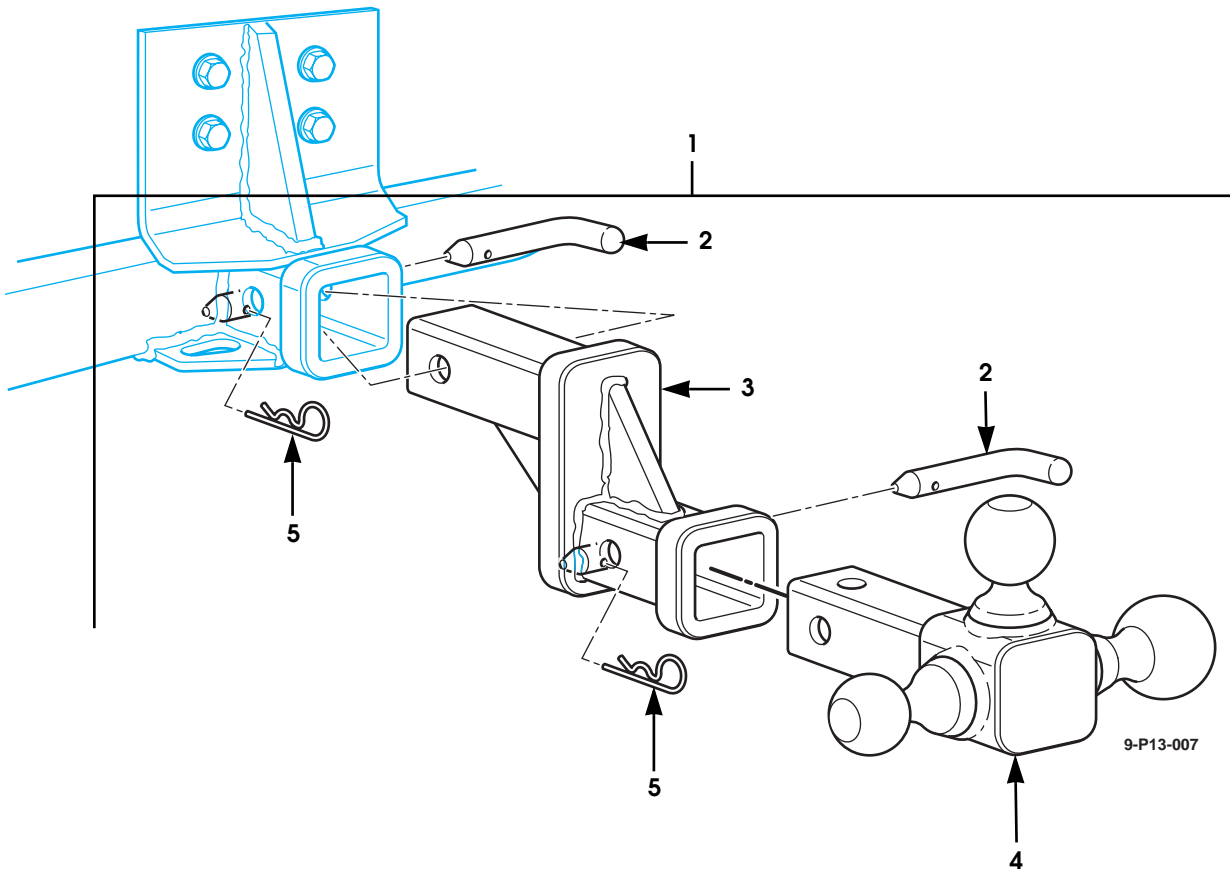

Figure 13-4. Tow Ball Assembly

# 2001 HUMMER PARTS CATALOG

## ACCESSORIES 13-11

ITEM	PART NUMBER	DESCRIPTION	QTY
		<b>Figure 13-4. Tow Ball Assembly</b>	
1	5744936	TOW BALL ASSEMBLY, 1 7/8", 2", and 2 5/16".....	1
2	S.I.K.	•PIN, anchor .....	2
3	S.I.K.	•OFFSET .....	1
4	S.I.K.	•BALL SET .....	1
5	S.I.K.	•PIN, retainer .....	2

# 2001 HUMMER PARTS CATALOG

## 13-12 ACCESSORIES

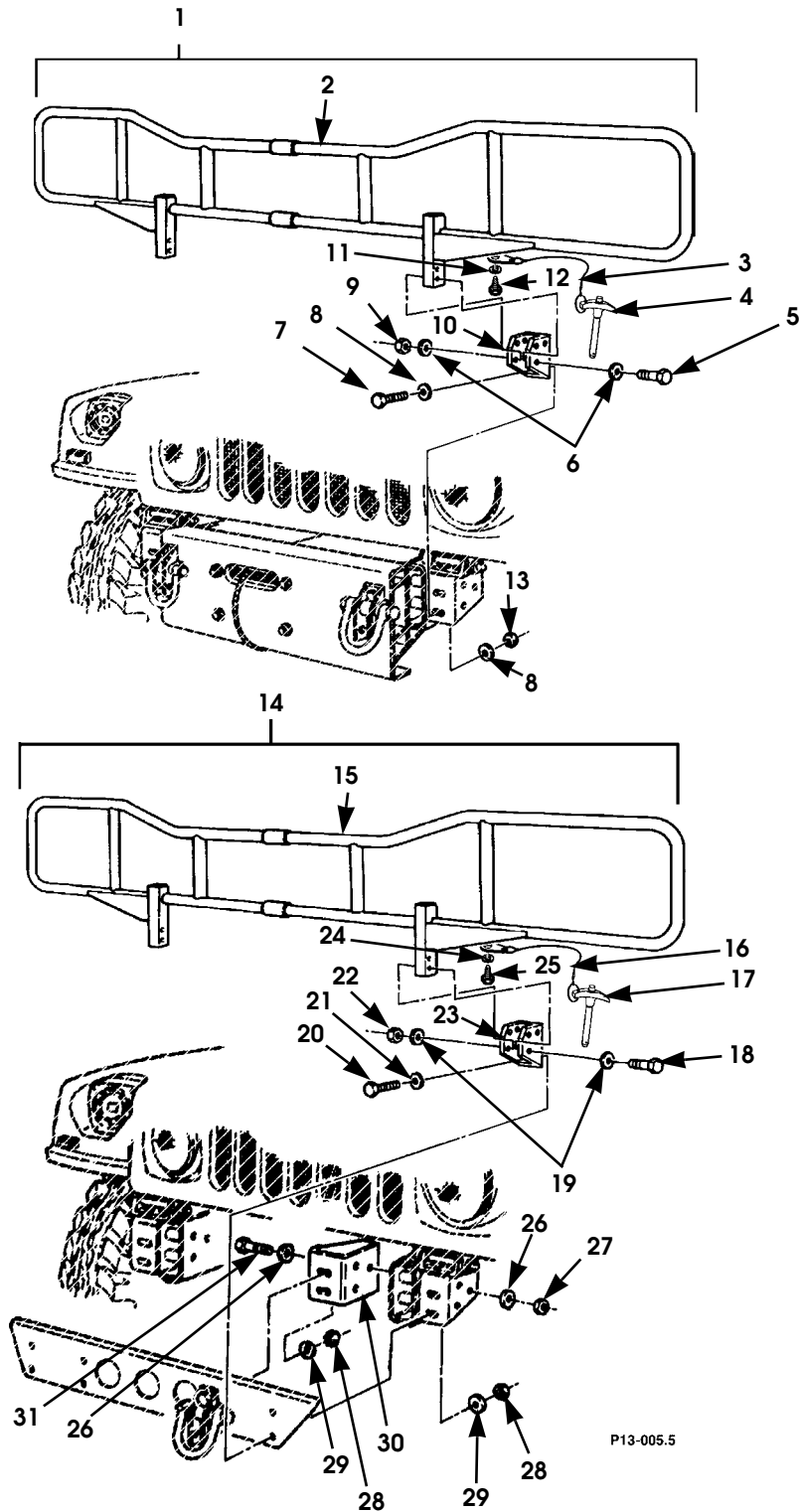

Figure 13-5. Brushguard Kit and Mounting Hardware.

# 2001 HUMMER PARTS CATALOG

## ACCESSORIES 13-13

ITEM	PART NUMBER	DESCRIPTION	QTY
		<b>Figure 13-5. Brushguard Kit and Mounting Hardware.</b>	
1	6000999	KIT, brushguard, vehicle w/ winch . . . . .	1
2	6000862	•BRUSHGUARD ASSEMBLY, w/winch . . . . .	1
3	5935839	•LANYARD, locking pin . . . . .	2
4	6007230	•PIN, quick release . . . . .	2
5	S.I.K.	•SCREW, 5/8 - 11 x 3 3/4, Gr8, CAD, bracket mounting	2
6	S.I.K.	•WASHER, flat, hard, 5/8, Type B, bracket mounting . .	16
7	S.I.K.	•BOLT, 1/2 - 13 x 1 3/4, Gr8, CAD, bracket mounting .	4
	5939266	•DECAL, brushguard (not illustrated) . . . . .	1
8	S.I.K.	•WASHER, flat, hardened, 1/2, type B, bracket mounting .	8
9	S.I.K.	•LOCKNUT, 5/8 - 11, bracket mounting, w/ winch . . . .	8
10	6000864B1	•BRACKET, brushguard support . . . . .	2
11	S.I.K.	•WASHER, 1/4. . . . .	2
12	S.I.K.	•SCREW, tapping, 1/4 - 14 x 1/2. . . . .	2
13	S.I.K.	•LOCKNUT, 1/2 - 13, Gr8, CAD, bracket mounting . . . .	4
14	6001000	KIT, brushguard, vehicle w/o winch. . . . .	1
15	6000862	•BRUSHGUARD ASSEMBLY, w/o winch . . . . .	1
16	5935839	•LANYARD, locking pin . . . . .	2
17	6007230	•PIN, locking. . . . .	2
18	S.I.K.	•SCREW, 5/8 - 11 x 3 3/4, Gr8, CAD, bracket mounting	2
19	S.I.K.	•WASHER, flat, hard, 5/8, type B, bracket mounting . .	16
20	S.I.K.	•BOLT, 1/2 - 13 x 1 3/4, Gr8, CAD, bracket mounting .	4
21	S.I.K.	•WASHER, flat, hard, 1/2, type B, bracket mounting . .	8
22	S.I.K.	•LOCKNUT, 5/8 - 11, bracket mounting, w/o winch . . . .	2
23	6000864B1	•BRACKET, brushguard support . . . . .	2
24	S.I.K.	•WASHER, 1/4. . . . .	2
25	S.I.K.	•SCREW, tapping, 1/4 - 14 x 1/2. . . . .	2
26	S.I.K.	•WASHER, flat, 5/8, type B, bracket mounting, w/o winch	16
27	S.I.K.	•LOCKNUT, 5/8 - 11, Gr8, CAD, w/o winch . . . . .	8
28	S.I.K.	•LOCKNUT, 1/2 - 13, Gr8, CAD, bracket mounting . . . .	4
29	S.I.K.	•WASHER, flat, hard, 1/2, type B, bracket mounting . .	8
30	6001552B5	•BRACKET, tow hook support, L.H., w/o winch . . . . .	1
30	6001553B5	•BRACKET, tow hook support, R.H., w/o winch. . . . .	1
31	S.I.K.	•SCREW, 5/8 - 11 x 3 3/4, Gr8, CAD, bracket mounting, w/o winch . . . . .	8
	5939266	•DECAL, brushguard (not illustrated) . . . . .	1



# 2001 HUMMER PARTS CATALOG

## 13-14 ACCESSORIES

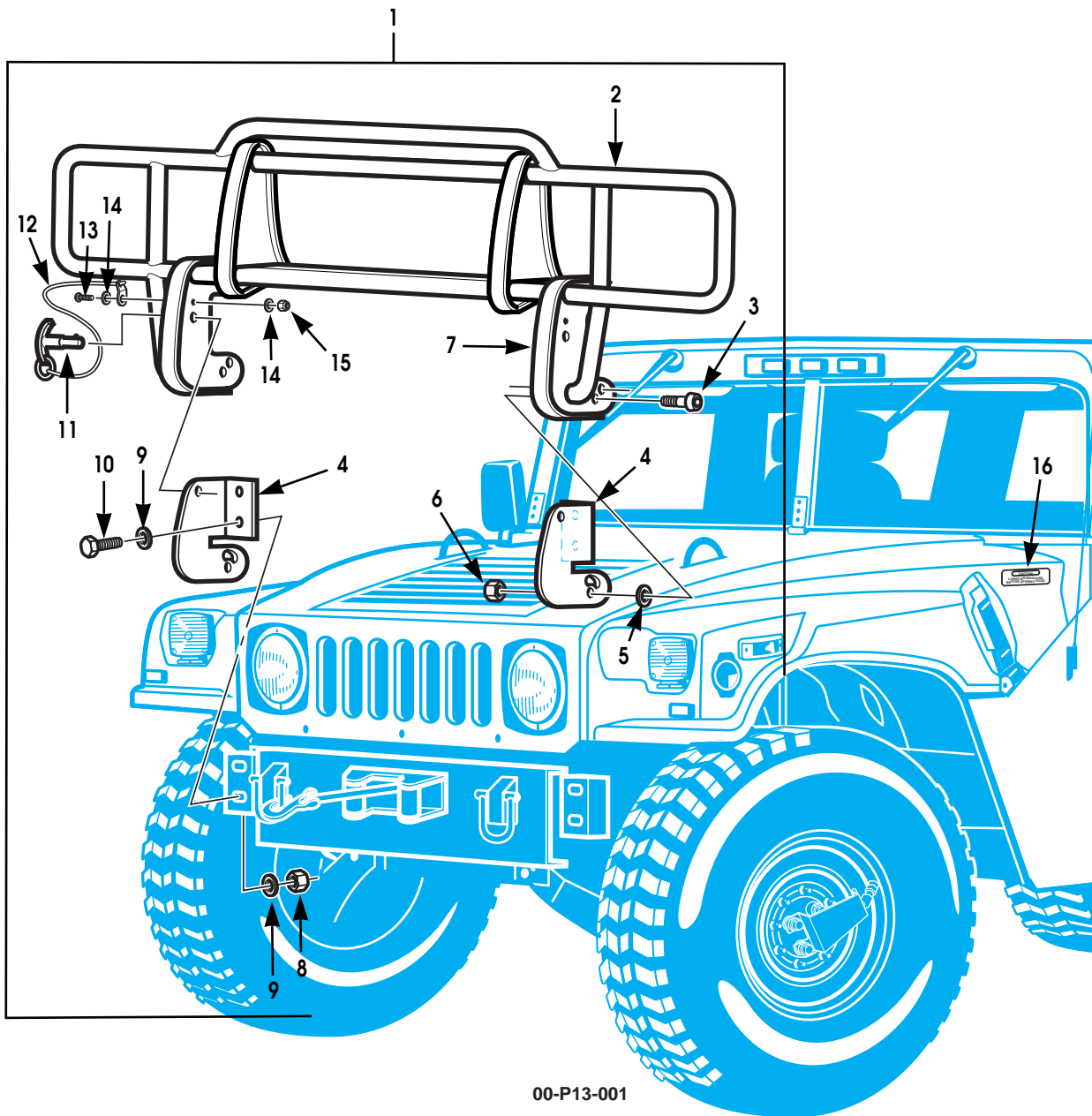

Figure 13-6. Brushguard Kit, Heavy Duty Accessory Frontal-Coverage.

# 2001 HUMMER PARTS CATALOG

## ACCESSORIES 13-15

ITEM	PART NUMBER	DESCRIPTION	QTY
		<b>Figure 13-6. Brushguard Kit, Heavy Duty Accessory Frontal-Coverage.</b>	
1	5745211	KIT, heavy duty accessory frontal-coverage brushguard	1
2	5745254	•BRUSHGUARD, frontal coverage . . . . .	1
3	S.I.K.	•BOLT, shoulder, 1/2 x 5/8", SEE NOTE 1 . . . . .	4
4	5745407	•BRACKET, mounting feet, SEE NOTE 1 . . . . .	2
5	S.I.K.	•WASHER, nylon, 1/2", SEE NOTE 1 . . . . .	4
6	S.I.K.	•NUT, flanged, 3/8 - 16, SEE NOTE 1 . . . . .	4
7	5745409	•GUARD, rubber . . . . .	4
8	S.I.K.	•NUT, 1/2", SEE NOTE 1 . . . . .	4
9	S.I.K.	•WASHER, 1/2", SEE NOTE 1 . . . . .	8
10	S.I.K.	•BOLT, 1/2 x 2", SEE NOTE 1 . . . . .	4
11	5745405	•LOCK PIN, SEE NOTE 1 . . . . .	2
12	5745406	•LANYARD, with stainless steel tab, 6", SEE NOTE 1 . . .	2
13	S.I.K.	•BOLT, button head, 1/4-20 x 3/4, SEE NOTE 1 . . . . .	2
14	S.I.K.	•WASHER, nylon, 1/4", SEE NOTE 1 . . . . .	4
15	S.I.K.	•LOCKNUT, 1/4", SEE NOTE 1. . . . .	2
16	5939266	DECAL, brushguard caution, English, SEE NOTE 2. . . . .	1
16	6002679	DECAL, brushguard caution, French, SEE NOTE 2. . . . .	1
16	6002019	DECAL, brushguard caution, Arabic, SEE NOTE 2. . . . .	1
		NOTE 1: COMPONENT OF MOUNTING HARDWARE AND BRACKETS KIT, P/N 5745408, WHICH CONSISTS OF THESE 12 ITEMS ONLY.	
		NOTE 2: IF THE VEHICLE WAS NOT PREVIOUSLY EQUIPPED WITH A BRUSHGUARD A CAUTION DECAL WILL NEED TO BE ORDERED IN THE APPROPRIATE LANGUAGE FOR AREA OF USE. DECALS DO NOT COME WITH THE BRUSHGUARD KIT.	

# 2001 HUMMER PARTS CATALOG

## 13-16 ACCESSORIES

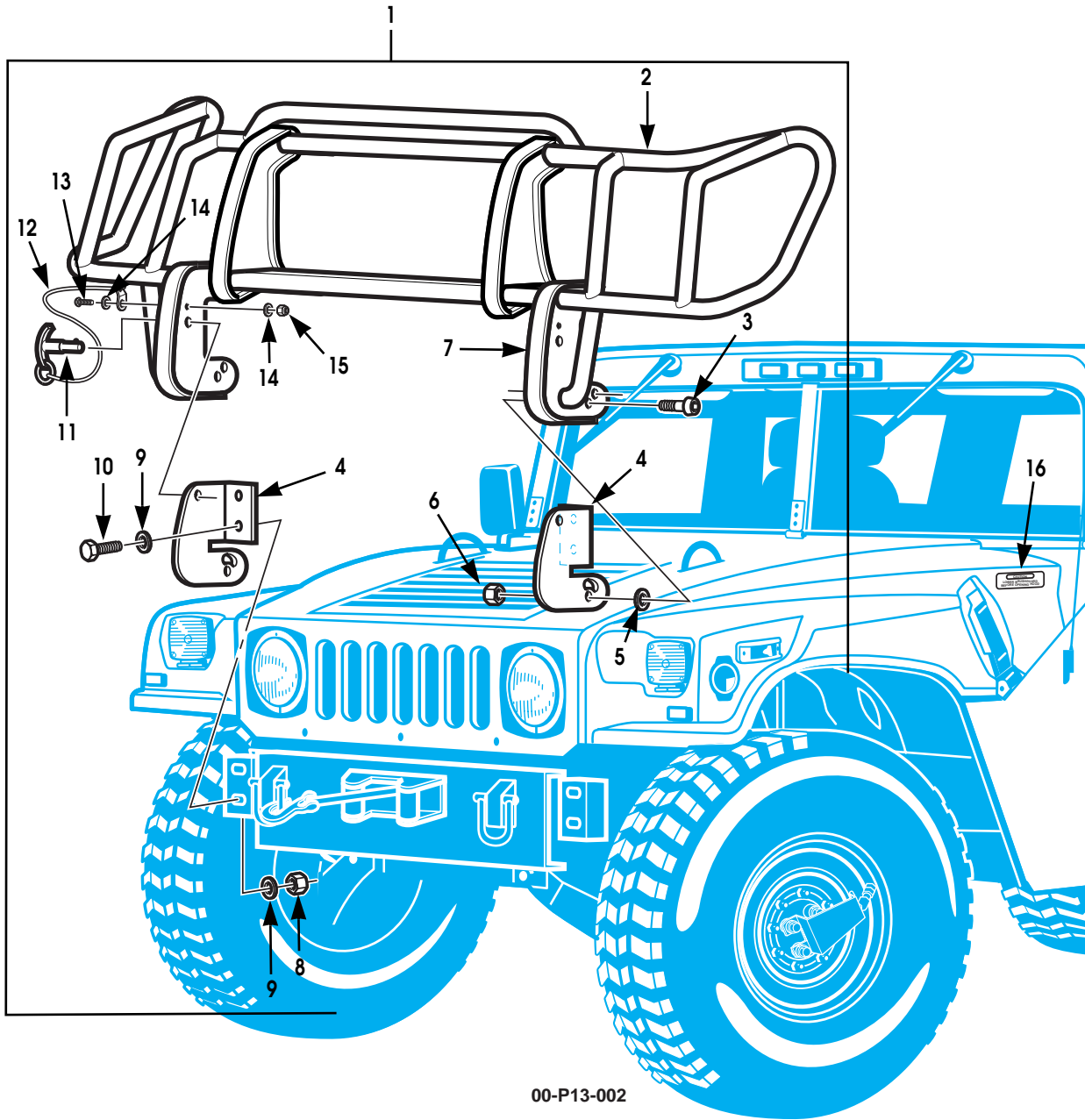

00-P13-002

Figure 13-7. Brushguard Kit, Heavy Duty Accessory Wrap-Around.

# 2001 HUMMER PARTS CATALOG

## ACCESSORIES 13-17

ITEM	PART NUMBER	DESCRIPTION	QTY
		<b>Figure 13-7.</b> <b>Brushguard Kit, Heavy Duty Accessory Wrap-Around.</b>	
1	5745210	KIT, heavy duty accessory wrap-around brushguard .	1
2	5745255	•BRUSHGUARD, wrap-around coverage . . . . .	1
3	S.I.K.	•BOLT, shoulder, 1/2 x 5/8", SEE NOTE 1 . . . . .	4
4	5745407	•BRACKET, mounting feet, SEE NOTE 1 . . . . .	2
5	S.I.K.	•WASHER, nylon, 1/2", SEE NOTE 1 . . . . .	4
6	S.I.K.	•NUT, flanged, 3/8 - 16, SEE NOTE 1 . . . . .	4
7	5745409	•GUARD, rubber . . . . .	4
8	S.I.K.	•NUT, 1/2", SEE NOTE 1 . . . . .	4
9	S.I.K.	•WASHER, 1/2", SEE NOTE 1 . . . . .	8
10	S.I.K.	•BOLT, 1/2 x 2", SEE NOTE 1 . . . . .	4
11	5745405	•LOCK PIN, SEE NOTE 1 . . . . .	2
12	5745406	•LANYARD, with stainless steel tab, 6", SEE NOTE 1 . . .	2
13	S.I.K.	•BOLT, button head, 1/4-20 x 3/4, SEE NOTE 1 . . . . .	2
14	S.I.K.	•WASHER, nylon, 1/4", SEE NOTE 1 . . . . .	4
15	S.I.K.	•LOCKNUT, 1/4", SEE NOTE 1 . . . . .	2
16	5939266	DECAL, brushguard caution, English, SEE NOTE 2 . . . . .	1
16	6002679	DECAL, brushguard caution, French, SEE NOTE 2 . . . . .	1
16	6002019	DECAL, brushguard caution, Arabic, SEE NOTE 2 . . . . .	1
		NOTE 1: COMPONENT OF MOUNTING HARDWARE AND BRACKETS KIT, P/N 5745408, WHICH CONSISTS OF THESE 12 ITEMS ONLY.	
		NOTE 2: IF THE VEHICLE WAS NOT PREVIOUSLY EQUIPPED WITH A BRUSHGUARD A CAUTION DECAL WILL NEED TO BE ORDERED IN THE APPROPRIATE LANGUAGE FOR AREA OF USE. DECALS DO NOT COME WITH THE BRUSHGUARD KIT.	

# 2001 HUMMER PARTS CATALOG

## 13-18 ACCESSORIES

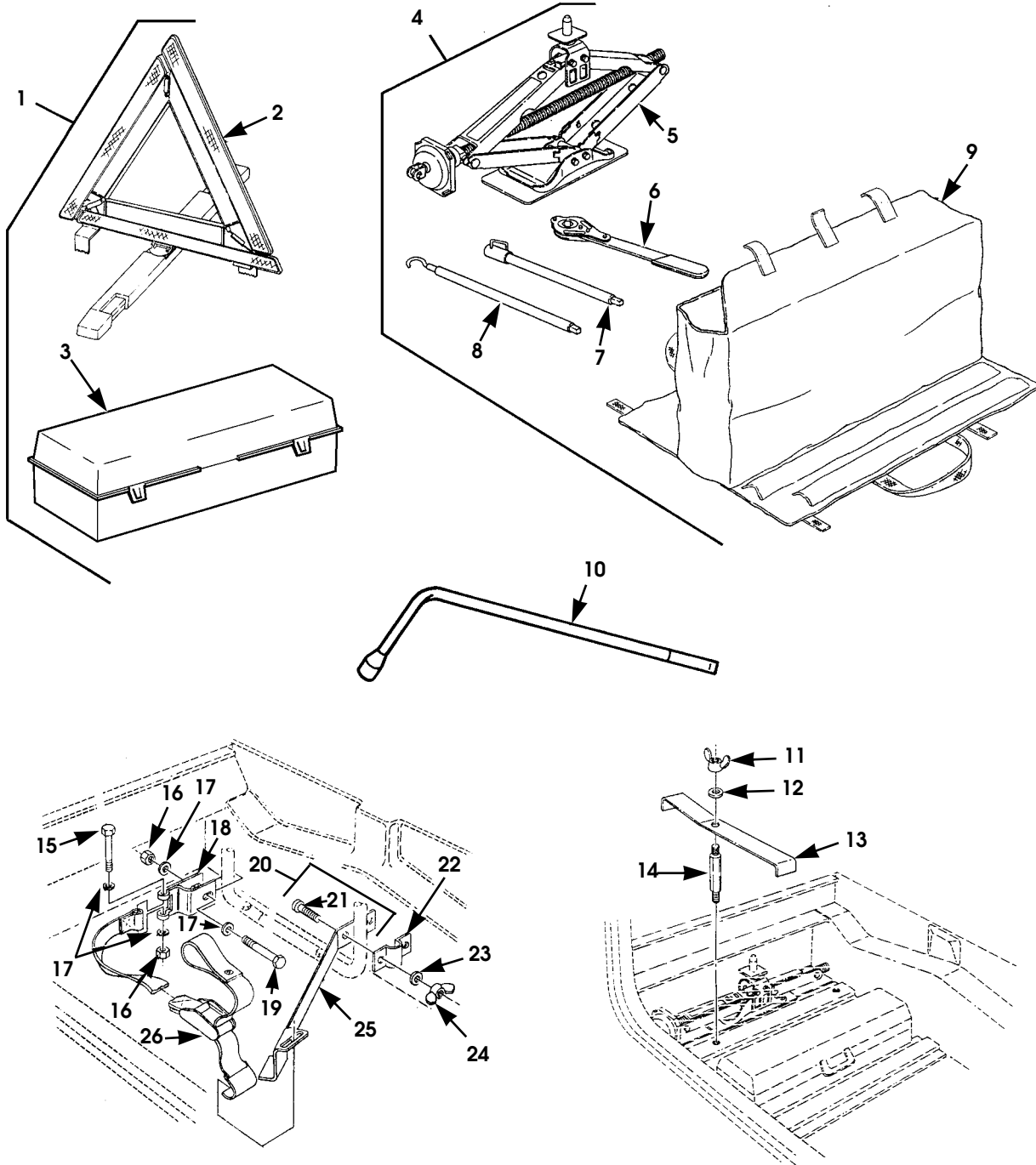

P13-006.1

Figure 13-8. Reflective Triangle Warning Device, Jack Assembly, and Mounting Hardware.

# 2001 HUMMER PARTS CATALOG

## ACCESSORIES 13-19

ITEM	PART NUMBER	DESCRIPTION	QTY
		<b>Figure 13-8. Reflective Triangle Warning Device, Jack Assembly, and Mounting Hardware.</b>	
1	11669000	KIT, Folding Reflective Triangle Warning Device. . . . .	1
2	S.I.K.	•WARNING TRIANGLE . . . . .	3
3	S.I.K.	•STORAGE CONTAINER. . . . .	1
4	5939822	JACK ASSEMBLY, scissor . . . . .	1
5	S.I.K.	•JACK, tire . . . . .	1
6	S.I.K.	•CRANK RATCHET . . . . .	1
7	S.I.K.	•CRANK EXTENSION . . . . .	1
8	S.I.K.	•CRANK . . . . .	1
9	6002031	BAG, jack/tool . . . . .	1
10	14009303	WRENCH, wheel lug . . . . .	1
10	5745304	WRENCH, wheel lug, for aluminum wheels. . . . .	1
11	N/S	WING NUT, 5/16 - 18, Steel. . . . .	2
12	N/S	89 WASHER, flat, 5/16, Type B, ZN . . . . .	2
13	6009332	89 BRACKET, jack hold-down. . . . .	2
14	6000161	89 STUD, jack hold-down . . . . .	2
15	N/S	89 BOLT, 1/4 - 20 x 2, Gr5, CAD. . . . .	1
16	N/S	83, 84, 90 NUT, 1/4 - 20, Gr8, ZN . . . . .	2
17	N/S	83, 84, 90 WASHER, flat, hard, 1/4, type B, ZN . . . . .	4
18	6000268B2	83, 84, 90 BRACKET ASSEMBLY, strap . . . . .	1
19	N/S	83, 84, 90 BOLT, 1/4 - 20 x 1 1/2, Gr5, ZN . . . . .	1
20	6000265B2	83, 84, 90 BRACKET ASSEMBLY, jack hold-down. . . . .	1
21	12339734-4	83, 84, 90 •STUD, jack hold-down bracket. . . . .	2
22	6000270B2	83, 84, 90 •BRACKET, clamping. . . . .	1
23	N/S	83, 84, 90 •WASHER, flat, #10, type B, ZN . . . . .	2
24	N/S	83, 84, 90 •WINGNUT, #10 - 24, steel . . . . .	2
25	N/S	83, 84, 90 •BRACKET, retaining . . . . .	1
26	6000273	83, 84, 90 STRAP ASSEMBLY . . . . .	1

# 2001 HUMMER PARTS CATALOG

## 13-20 ACCESSORIES

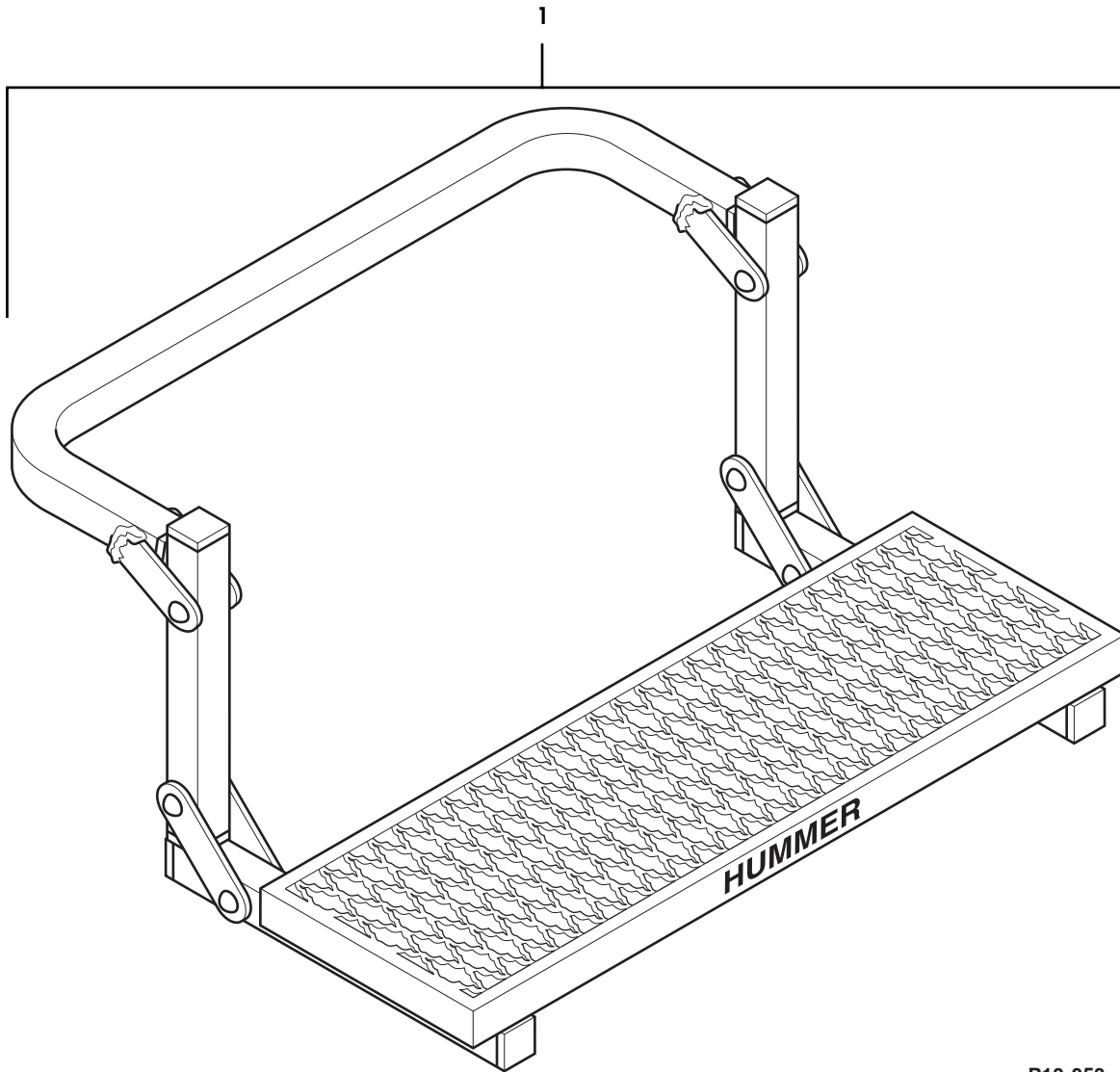

P13-053

*Figure 13-9. Utility Step*

# 2001 HUMMER PARTS CATALOG

## ACCESSORIES 13-21

ITEM	PART NUMBER	DESCRIPTION	QTY
1	5744641 S.I.A.	<p><b>Figure 13-9.</b> <b>Utility Step</b></p> <p>STEP ASSEMBLY, utility, red . . . . .</p> <p>•BAG, heavy-duty canvas, black . . . . .</p>	1  1



# 2001 HUMMER PARTS CATALOG

## 13-22 ACCESSORIES

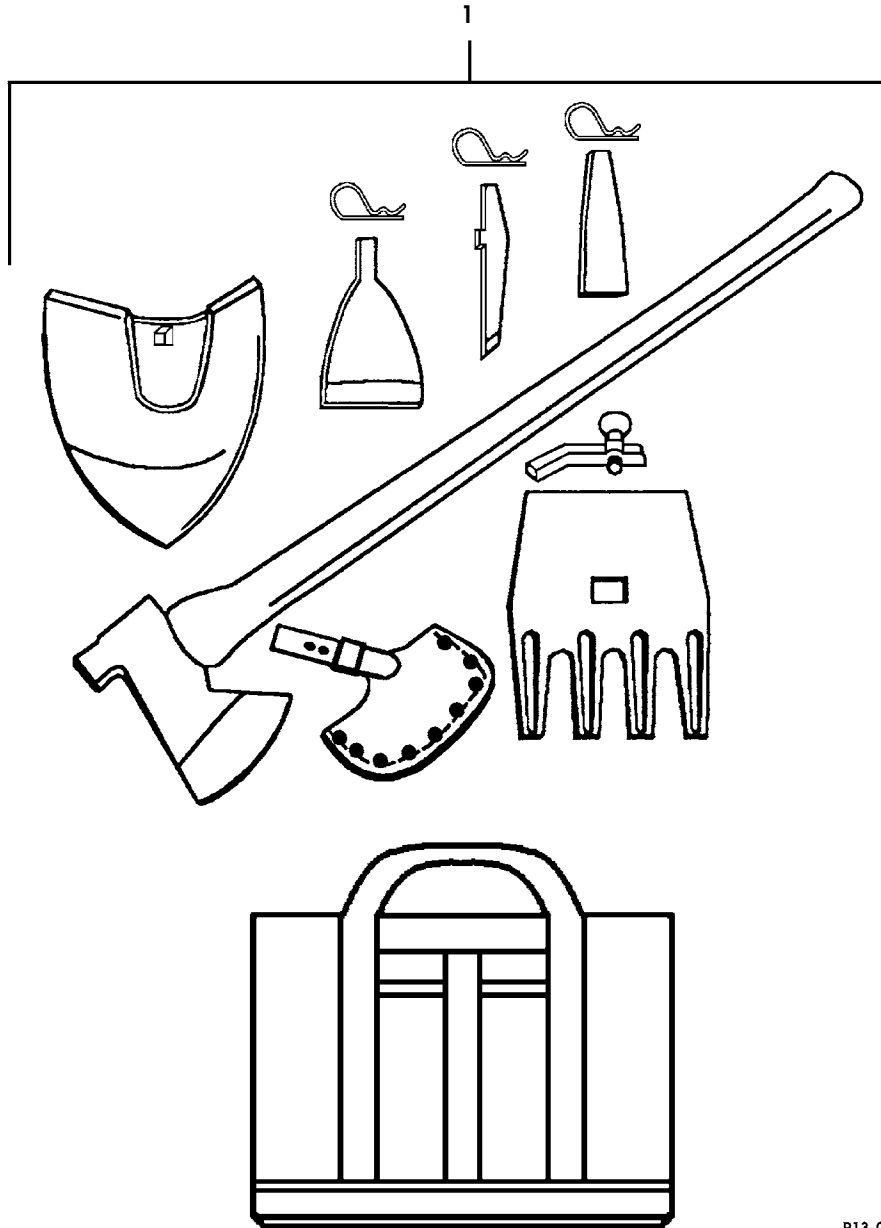

P13-038

*Figure 13-10. Pioneer Tool Kit.*

# 2001 HUMMER PARTS CATALOG

## ACCESSORIES 13-23

ITEM	PART NUMBER	DESCRIPTION	QTY
1	6004898	Figure 13-10. Pioneer Tool Kit.  KIT, pioneer tool .....	1

# 2001 HUMMER PARTS CATALOG

## 13-24 ACCESSORIES

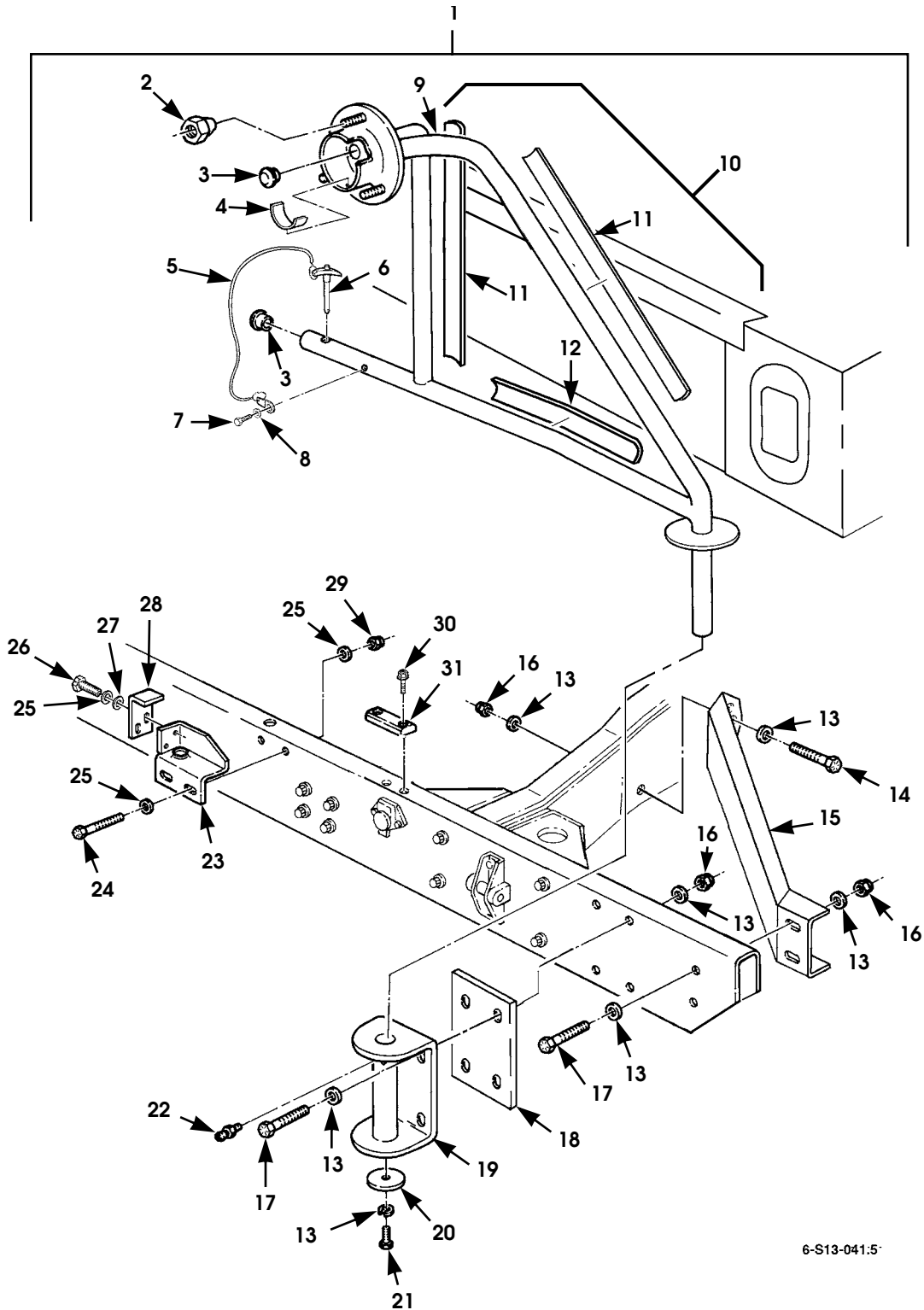

6-S13-041:5

Figure 13-11. Spare Tire Carrier Kit, Swing-Away (Steel Wheels Only).

# 2001 HUMMER PARTS CATALOG

## ACCESSORIES 13-25

ITEM	PART NUMBER	DESCRIPTION	QTY
		<b>Figure 13-11.</b> <b>Spare Tire Carrier Kit, Swing-Away (Steel Wheels Only).</b>	
1	5744642	KIT, swing-away spare tire carrier. . . . .	1
2	6007340P2	•LUGNUT, flanged, 9/16 . . . . .	3
3	5935349	•PLUG, hole . . . . .	3
4	6004008	•DECAL, spare tire warning . . . . .	1
5	5935839	•LANYARD . . . . .	1
6	6007230	•PIN, spare tire carrier. . . . .	1
7	S.I.K.	•SCREW, tapping, 1/4 - 14 x 5/8, Phos . . . . .	1
8	S.I.K.	•WASHER, flat, 1/4 . . . . .	1
9	6007764B9	•FRAME, swing-away spare tire . . . . .	1
10	5744553	•SWING-AWAY CUSHION, 40" long, SEE NOTE 1 . . . . .	1
11		••SWING-AWAY CUSHION, 15", SEE NOTE 2 . . . . .	2
12		••SWING-AWAY CUSHION, 10", SEE NOTE 2 . . . . .	1
13	S.I.K.	•WASHER, flat, hard, 1/2, type B . . . . .	14
14	S.I.K.	•BOLT, 1/2 - 13 x 3 3/4, Gr8, CAD . . . . .	1
15	12339186	•BRACE, bumper, R.H. . . . .	1
16	S.I.K.	•LOCKNUT, 1/2 - 13 . . . . .	7
17	S.I.K.	•BOLT 1/2 - 13 x 3, Gr8, CAD. . . . .	6
18	6002620B2	•SPACER . . . . .	1
19	6011123B9	•BRACKET, spare tire mounting . . . . .	1
20	5935291B9	•PLATE, tube retainer . . . . .	1
21	S.I.K.	•BOLT, 5/16 - 18 x 1.00, Gr5, Cad . . . . .	1
22	S.I.K.	•FITTING, lubrication . . . . .	1
23	6008049B2	•BRACKET, tire carrier stop . . . . .	1
24	S.I.K.	•BOLT, 5/16 - 18 x 3, Gr8, Cad. . . . .	2
25	S.I.K.	•WASHER, flat, 5/16 . . . . .	6
26	S.I.K.	•BOLT, 5/16 - 18 x 3/4, Gr8, ZN. . . . .	2
27	S.I.K.	•LOCKWASHER, med, 5/16 . . . . .	3
28	6008056B2	•BRACKET, carrier, hold down . . . . .	1
29	S.I.K.	•LOCKNUT, 5/16 - 18, Gr8 . . . . .	2
30	S.I.K.	•SCREW, 1/4 - 20 x 7/8, ZN. . . . .	2
31	5935281	•BLOCK, guide. . . . .	1
		NOTE 1: CUT INTO THREE PIECES: TWO OF 15 INCHES, ONE OF 10 INCHES	
		NOTE 2: MADE FROM 40-INCH CUSHION 5744553.	

# 2001 HUMMER PARTS CATALOG

## 13-26 ACCESSORIES

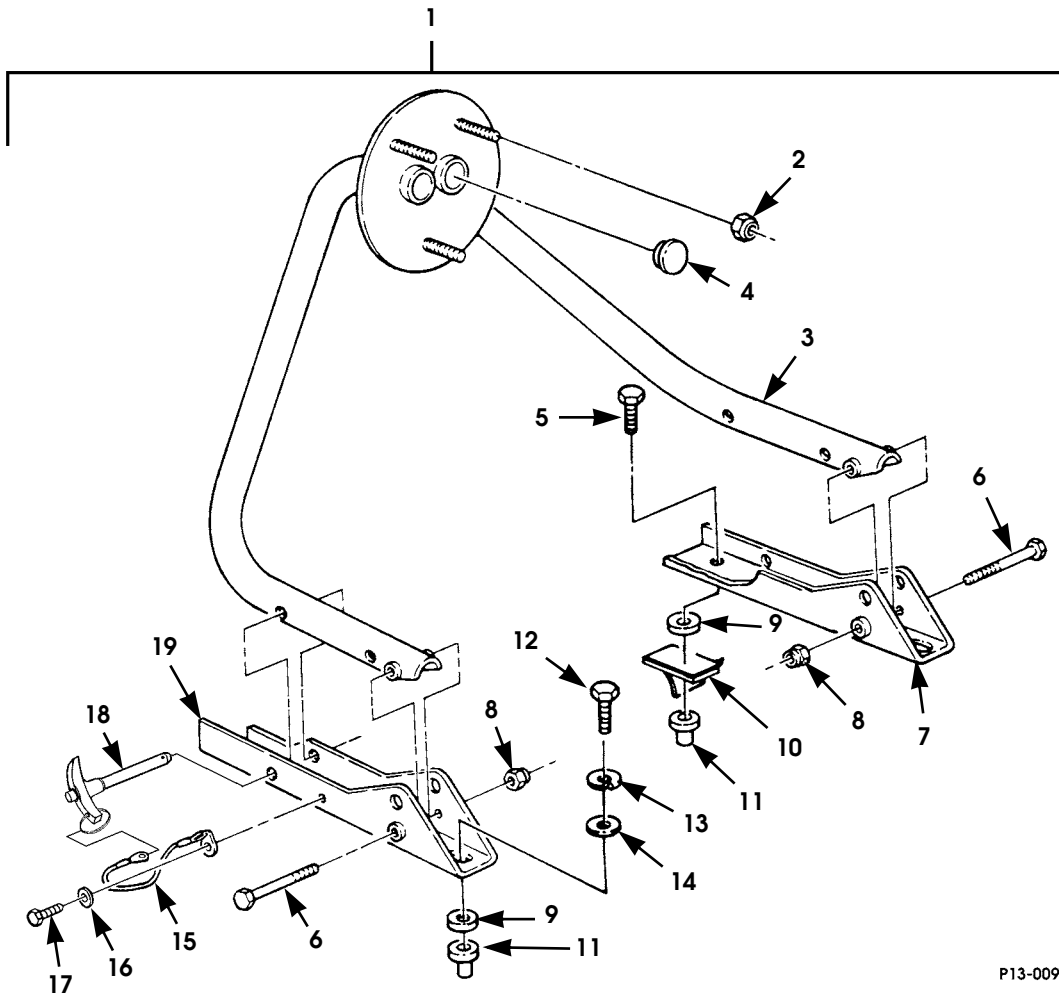

P13-009.1

Figure 13-12. Spare Tire Carrier, Bed-Mounted (Steel Wheels Only).

# 2001 HUMMER PARTS CATALOG

## ACCESSORIES 13-27

ITEM	PART NUMBER	DESCRIPTION	QTY
		<b>Figure 13-12. Spare Tire Carrier, Bed-Mounted (Steel Wheels Only).</b>	
1	5742944	KIT, bed-mounted spare tire carrier. . . . . 82, 83, 89	1
2	6007340P2	•LUGNUT, flanged, 9/16 - 18. . . . .	3
3	6008230B3	•SPARE TIRE FRAME ASSEMBLY . . . . .	1
4	5935349	••PLUG, 1/4 - 20 x 7/8. . . . .	2
5	MS24667-54P2	•SCREW, countersunk, socket head . . . . .	4
6	S.I.K.	•BOLT, 1/2 - 13 x 3 1/2, Gr5, Phos. . . . .	2
7	6000931B2	•MOUNTING BRACKET, R.H. . . . .	1
8	S.I.K.	•NUT, 1/2 - 13, Gr8, CAD . . . . .	2
9	6000942B2	•SPACER . . . . .	6
10	12339376-1	•ADHESIVE-BACKED TAPE. . . . .	2
11	5935428	•RIVNUT, 3/8 - 16, ZN . . . . .	5
12	S.I.K.	•SCREW, 3/8 - 16 x 1 3/4, Gr5, CAD. . . . .	2
13	S.I.K.	•LOCKWASHER, med, 3/8, Phos . . . . .	2
14	S.I.K.	•WASHER, flat, 3/8, type B. . . . .	2
15	5935839	•LANYARD . . . . .	2
16	S.I.K.	•WASHER, flat, 1/4 . . . . .	2
17	S.I.K.	•SCREW, tapping, 1/4 - 14 x 1/2, Phos . . . . .	2
18	6007230	•LOCKPIN. . . . .	2
19	6000930B3	•MOUNTING BRACKET, L.H. . . . .	1

# 2001 HUMMER PARTS CATALOG

## 13-28 ACCESSORIES

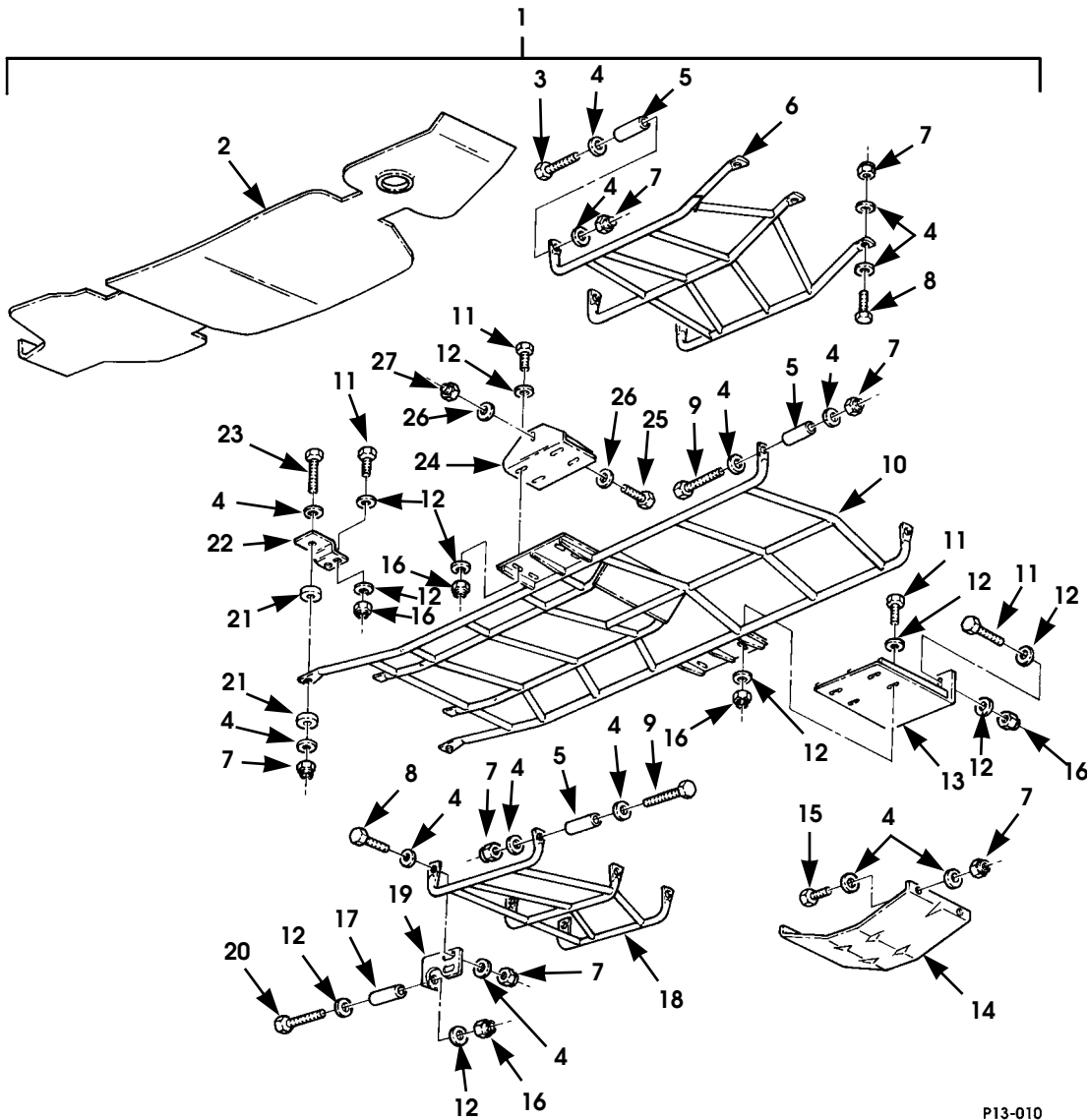

Figure 13-13. Driveline Protection and Mounting Hardware.

# 2001 HUMMER PARTS CATALOG

## ACCESSORIES 13-29

ITEM	PART NUMBER	DESCRIPTION	QTY
		<b>Figure 13-13.</b> <b>Driveline Protection and Mounting Hardware.</b>	
1	5744299	KIT, underbody protection, vehicle w/o winch . . . . .	1
1	5744281	KIT, underbody protection, vehicle w/ winch, SEE NOTE 1 . . . . .	1
2	6006150B9	•SHIELD, fuel tank . . . . .	1
3	S.I.K.	•BOLT, 3/8 - 16 x 3 1/4, Gr8, Phos. . . . .	5
4	S.I.K.	•WASHER, flat, 3/8, type B (use w/ kit P/N 5744299). . .	40
4	S.I.K.	•WASHER, flat, 3/8, type B (use w/ kit P/N 5744281) . .	30
5	5594341	•SPACER, front . . . . .	3
6	5593490	•FRONT SHIELD ASSEMBLY. . . . .	1
7	S.I.K.	•LOCKNUT, 3/8 - 16, Gr8 (use w/ kit P/N 5744299) . . . .	20
7	S.I.K.	•LOCKNUT, 3/8 - 16, Gr8 (use w/ kit P/N 5744281). . . .	14
8	S.I.K.	•SCREW, cap, 3/8 - 16 x 1 1/8, Gr8, CAD . . . . .	7
9	S.I.K.	•BOLT, 3/8 - 16 x 3 3/4, Gr8, Phos. . . . .	1
10	5593491	•INTERMEDIATE SHIELD ASSEMBLY . . . . .	1
11	S.I.K.	•BOLT, 5/16 - 18 x 1, Gr8, CAD. . . . .	12
12	S.I.K.	•WASHER, flat, 5/16, hardened, type B, ZN . . . . .	36
13	5593494	•BRACKET ASSEMBLY, shield mounting, L.H.. . . . .	1
14	5593499	•SHIELD, transfer case . . . . .	1
15	S.I.K.	•BOLT, 3/8 - 16 x 1, Gr8, CAD. . . . .	2
16	S.I.K.	•LOCKNUT, 5/16 - 18, Gr8 . . . . .	18
17	5594342	•SPACER, underbody protection, rear . . . . .	9
18	5593492	•REAR SHIELD ASSEMBLY. . . . .	1
19	12447145	•BRACKET, tube rear mounting . . . . .	3
20	S.I.K.	•BOLT, 5/16 - 18 x 2 3/4, Gr8, ZN . . . . .	6
21	5593496	•WASHER, laminated fiber, 3/8. . . . .	4
22	5593496	•BRACKET, tube support transmission . . . . .	2
23	S.I.K.	•BOLT, 3/8 - 16 x 1 1/2, Gr8, CAD. . . . .	2
24	5593495	•BRACKET ASSEMBLY, shield mounting, R.H. . . . .	1
25	S.I.K.	•BOLT, 1/2 - 13 x 3 3/4, Gr8, CAD . . . . .	2
26	S.I.K.	•WASHER, flat, hardened, 1/2. . . . .	4
27	S.I.K.	•LOCKNUT, 1/2 - 13 . . . . .	2
		NOTE 1: FOR SKID PLATE INFORMATION, REFER TO DRIVELINE PROTECTION SKID PLATES ON NEXT PAGE.	



# 2001 HUMMER PARTS CATALOG

## 13-30 ACCESSORIES

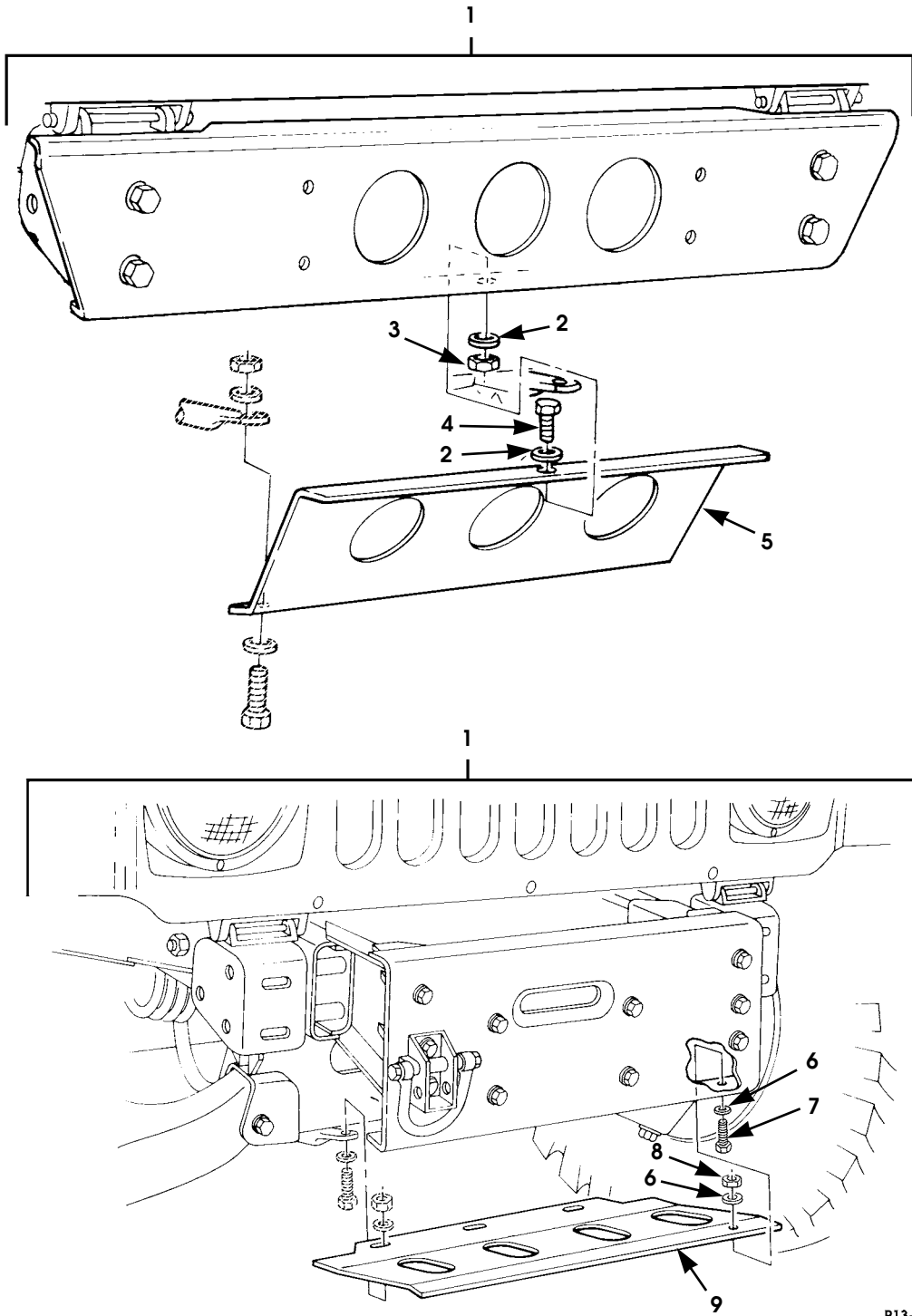

P13-011

Figure 13-14. Driveline Protection Skid Plates.

# 2001 HUMMER PARTS CATALOG

## ACCESSORIES 13-31

ITEM	PART NUMBER	DESCRIPTION	QTY
		<b>Figure 13-14.</b> <b>Driveline Protection Skid Plates.</b>	
1	5744299	KIT, underbody protection, vehicle w/o winch . . . . .	1
1	5744281	KIT, underbody protection, vehicle w/winch . . . . .	1
2	S.I.K.	•WASHER, flat, 5/16, hard, type B, ZN, w/o winch . . . . .	8
3	S.I.K.	•LOCKNUT, 5/16 - 18, Gr8, w/o winch . . . . .	4
4	S.I.K.	•BOLT, 5/16 - 18 x 1, Gr8, Phos, w/o winch. . . . .	4
5	5935943	•SKID PLATE w/o winch. . . . .	1
6	S.I.K.	•WASHER, flat, 3/8, type B, w/winch . . . . .	6
7	S.I.K.	•BOLT, 3/8 - 16 x 1, w/winch, Gr8, CAD . . . . .	3
8	S.I.K.	•LOCKNUT, 3/8 - 16, Gr8, w/winch . . . . .	3
9	5935669	•SKID PLATE w/winch . . . . .	1
		NOTE 1: FOR DRIVELINE PROTECTION PARTS, REFER TO DRIVELINE PROTECTION AND MOUNTING HARDWARE ON PAGES 13-28 AND 13-29.	

# 2001 HUMMER PARTS CATALOG

## 13-32 ACCESSORIES

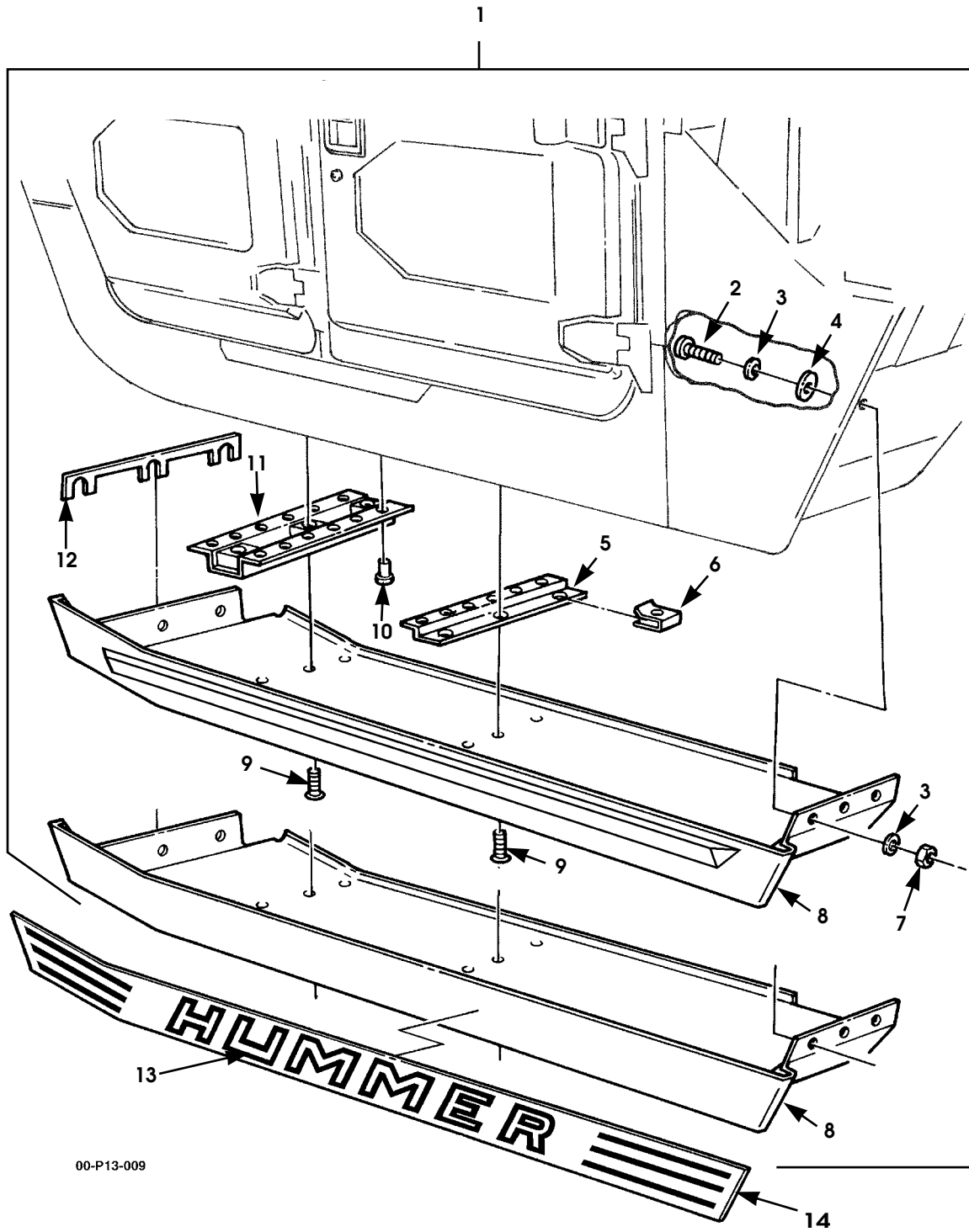

Figure 13-15. Rocker Panel Guard Accessory Kit.

# 2001 HUMMER PARTS CATALOG

## ACCESSORIES 13-33

ITEM	PART NUMBER	DESCRIPTION	QTY
		<b>Figure 13-15. Rocker Panel Guard Accessory Kit.</b>	
1	5745331	KIT, rocker panel protection (steel, w/reinforcements)	1
1	5745332	KIT, rocker panel protection (aluminum) . . . . .	1
1	5742908	KIT, rocker panel protection (steel) . . . . .	1
2	S.I.K.	•CAPSCREW, socket head, 3/8 - 16 x 1 1/4 , CAD . . .	12
3	S.I.K.	•WASHER, flat, 3/8. . . . .	24
4	6001595	•GASKET, foam washer . . . . .	12
5	6001241	•BRACKET, mounting. . . . .	2
6	6001283	•NUT, U-type. . . . .	9
7	S.I.K.	•LOCKNUT, 3/8 - 16, Gr8. . . . .	12
8	5745169	•PANEL, underbody skid, L.H. (steel), w/welded side reinforcements, SEE NOTE 1 . . . . .	1
8	5745170	•PANEL, underbody skid, R.H.(steel), w/welded side reinforcements, SEE NOTE 1 . . . . .	1
8	6005165B5	•PANEL, underbody skid, L.H. (aluminum), SEE NOTE 2	1
8	6005166B5	•PANEL, underbody skid, R.H. (aluminum), SEE NOTE 2 .	1
8	6003614P	•PANEL, underbody skid, L.H. (steel), SEE NOTE 3 . . . . .	1
8	6003615P	•PANEL, underbody skid, R.H. (steel), SEE NOTE 3. . . . .	1
9	S.I.K.	•SCREW, socket, 3/8"-16 x 1.0 FL HD ZN W/Nylon. . . . .	12
10	S.I.K.	•RIVET, 3/16 dia., blind, aluminum . . . . .	48
11	6001275	•BRACKET, skid plate mounting . . . . .	3
12	6001278	•SHIM, skid plate . . . . .	6
13	5744675	DECAL, Hummer, black, SEE NOTE 4. . . . .	1
13	6004296	DECAL, Hummer, gold, SEE NOTE 4 . . . . .	1
13	6004295	DECAL, Hummer, silver, SEE NOTE 4. . . . .	1
13	6004294	DECAL, Hummer, white, SEE NOTE 4. . . . .	1
13	5744882	DECAL, Hummer, chrome, SEE NOTE 4. . . . .	1
14	5745140	KIT, rocker panel protection cover, polished stainless steel, SEE NOTE 5 . . . . .	1
14	5745200	KIT, rocker panel protection cover, brushed stainless steel, SEE NOTE 5 . . . . .	1
		NOTE 1: PART OF KIT P/N 5745331	
		NOTE 2: PART OF KIT P/N 5745332	
		NOTE 3: PART OF KIT P/N 5742908	
		NOTE 4: NOT INCLUDED IN KIT - ORDER SEPARATELY (SHIPPED IN PAIRS ONLY)	
		NOTE 5: KIT INCLUDES RH AND LH COVERS	

# 2001 HUMMER PARTS CATALOG

## 13-34 ACCESSORIES

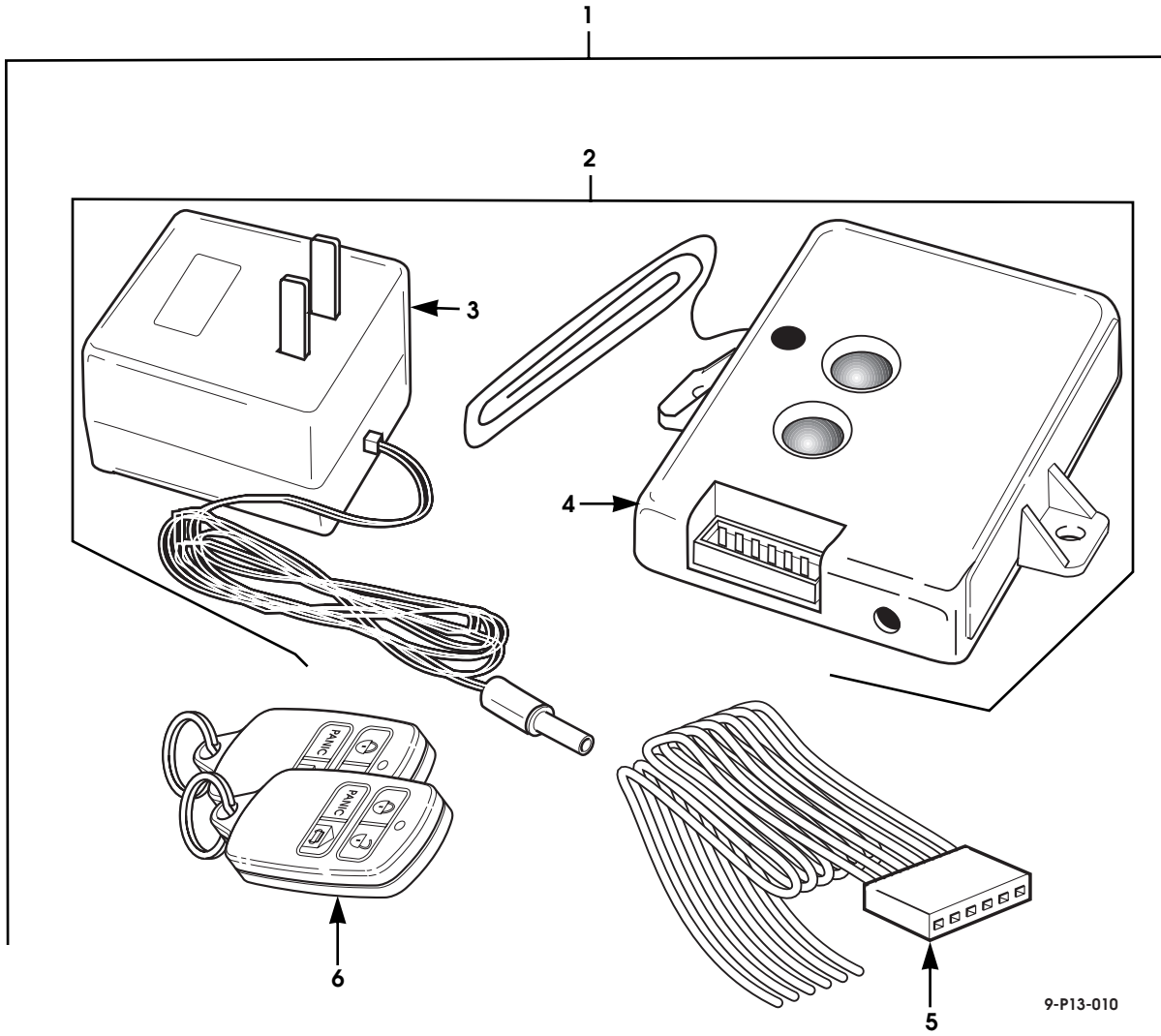

9-P13-010

Figure 13-16. Remote Entry Kits.

# 2001 HUMMER PARTS CATALOG

## ACCESSORIES 13-35

ITEM	PART NUMBER	DESCRIPTION	QTY
		<b>Figure 13-16. Remote Entry Kits.</b>	
1	5745076	KIT, remote entry, 4-button . . . . .	1
2	6010413	•RECEIVER MODULE ASSEMBLY, garage door, 4-button	1
3	S.I.A.	••D.C. VOLTAGE CONVERTER, power supply . . . . .	1
4	S.I.A.	••RECEIVER MODULE, garage door, 4-button . . . . .	1
5	6010425	•HARNESS ASSEMBLY, garage door interface switch. .	1
6	6010411	•TRANSMITTER, 4-button . . . . .	2
	6010412	RECEIVER MODULE, 4-button (not illustrated) . . . . .	2

# 2001 HUMMER PARTS CATALOG

## 13-36 ACCESSORIES

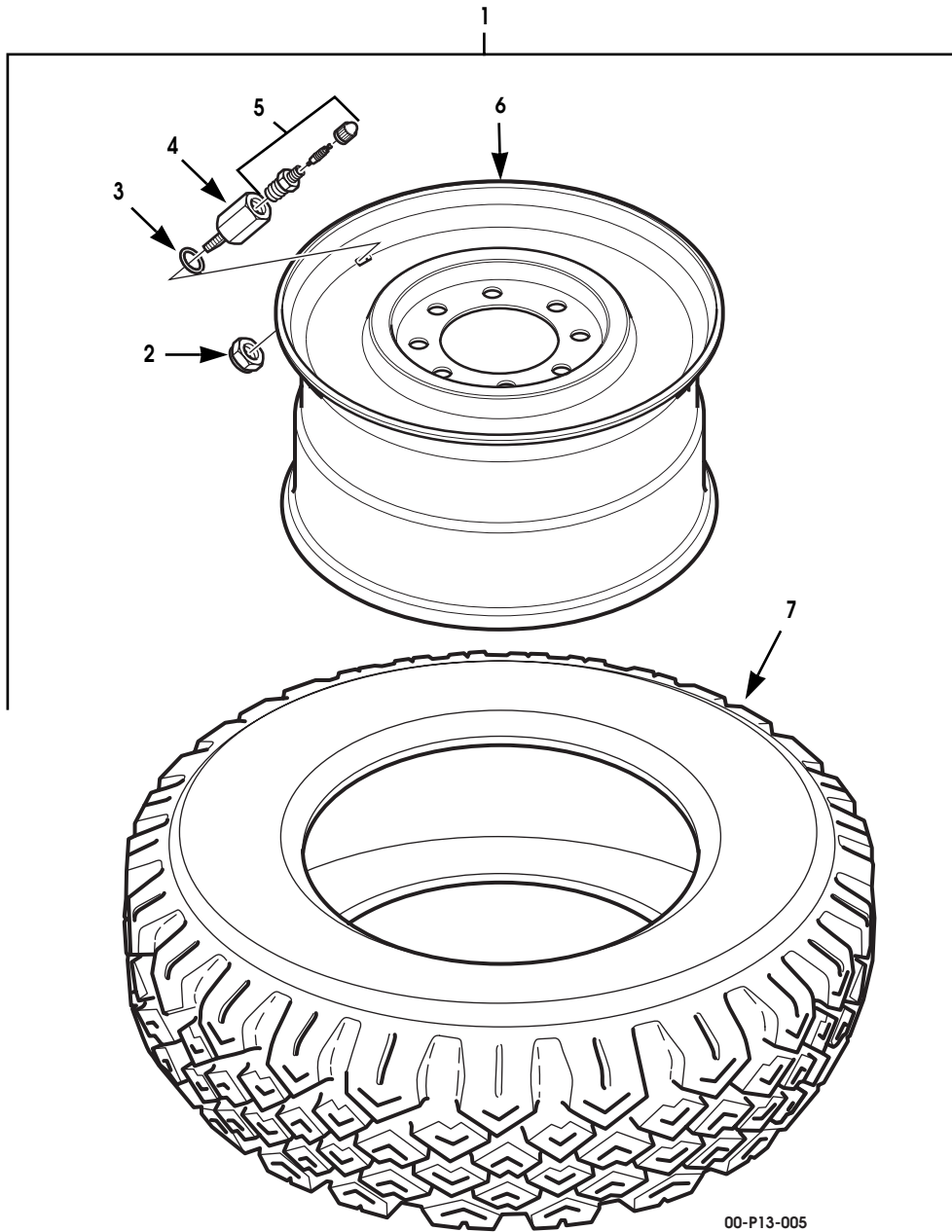

Figure 13-17. Wheel and Tire Assembly, SpaceSaver Spare.

# 2001 HUMMER PARTS CATALOG

## ACCESSORIES 13-37

ITEM	PART NUMBER	DESCRIPTION	QTY
		<b>Figure 13-17.</b> <b>Wheel and Tire Assembly, SpaceSaver Spare.</b>	
1	6008983B2	WHEEL ASSEMBLY, spacesaver . . . . .	1
2	MS21245-8	• LOCKNUT, wheel assembly. . . . .	1
3	12342794	• O-RING, wheel assembly . . . . .	1
4	12342793	• INSERT, wheel assembly . . . . .	1
5	12342634	• VALVE, pneumatic, wheel assembly . . . . .	1
6	6005783P	• WHEEL, one-piece. . . . .	1
7	6008982	• TIRE, SpaceSaver, 9.50R16.5LT, load rating E . . . . .	1



# 2001 HUMMER PARTS CATALOG

## 13-38 ACCESSORIES

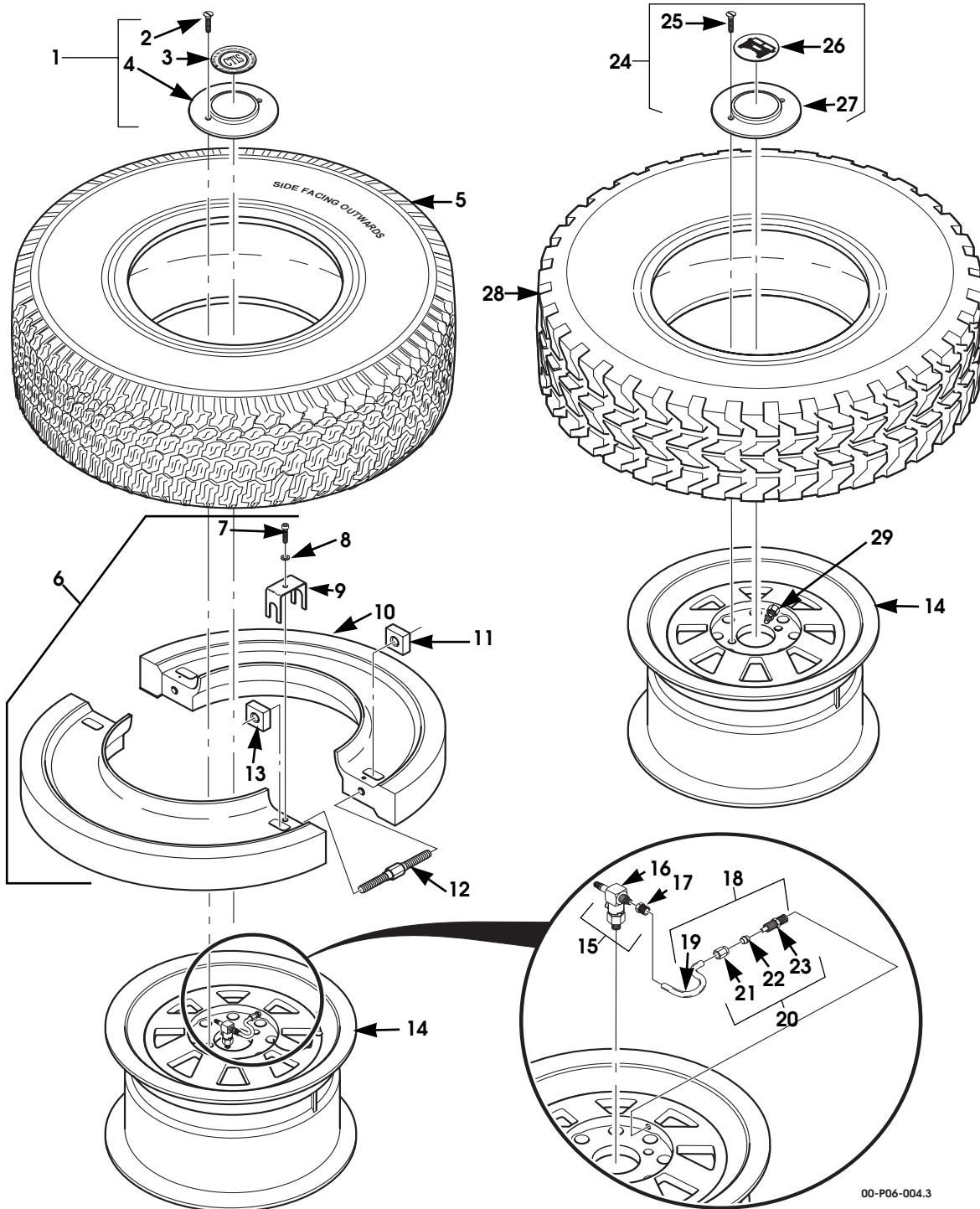

00-P06-004.3

Figure 13-18. Wheel, Tire, and Runflat Assembly, One-Piece Aluminum Rim, 16.5" (Optional).

# 2001 HUMMER PARTS CATALOG

## ACCESSORIES 13-39

ITEM	PART NUMBER	DESCRIPTION	QTY
		<b>Figure 13-18. Wheel, Tire, and Runflat Assembly, One-Piece Aluminum Rim, 16.5" (Optional).</b>	
1	6011260	LUG COVER ASSEMBLY, with CTIS . . . . .	4
2	6011548	•SCREW, center cover, aluminum wheel . . . . .	8
3	6011281	•DISK, wheel lug cover, with CTIS. . . . .	4
4	6011280	•COVER, wheel lug. . . . .	4
5	6002923	TIRE, Wrangler, GSA, 37 x 12.50 R - 16.5 . . . . .	4
5	12342644	TIRE, radial, MT, 37 x 12.50 R - 16.5. . . . .	4
6	6011266	RUNFLAT ASSEMBLY . . . . .	4
7	S.I.A.	•SCREW . . . . .	8
8	S.I.A.	•WASHER . . . . .	8
9	S.I.A.	•BRACKET, security . . . . .	8
10	S.I.A.	•RUNFLAT HALF . . . . .	8
11	S.I.A.	•SQUARE NUT, RH Thread . . . . .	8
12	S.I.A.	•SCREW, N-12. . . . .	8
13	S.I.A.	•SQUARE NUT, LH Thread . . . . .	8
14	6011251	WHEEL, one-piece aluminum, 16.5" . . . . .	4
15	6005109	VALVE ASSEMBLY, quick disconnect. . . . .	4
16	S.I.A.	•VALVE BODY. . . . .	4
17	S.I.A.	•TUBE NUT. . . . .	4
18	5745243	CTIS WHEEL TUBE ASSEMBLY . . . . .	4
19	S.I.A.	•TUBE, wheel, CTIS . . . . .	4
20	S.I.A.	•FITTING ASSEMBLY, CTIS wheel tube . . . . .	4
21	S.I.A.	••TUBE NUT. . . . .	4
22	S.I.A.	••FERRULE . . . . .	4
23	S.I.A.	••CONNECTOR. . . . .	4
24	6011252	LUG COVER ASSEMBLY, w/o CTIS . . . . .	4
25	6011548	•SCREW, center cover, aluminum wheel . . . . .	8
26	6011282	•DISK, wheel lug cover, non-CTIS. . . . .	4
27	6011280	•COVER, wheel lug. . . . .	4
28	12342644	TIRE, radial, MT . . . . .	4
28	6002923	TIRE, Wrangler, GSA . . . . .	4
29	6011283	TANK VALVE . . . . .	4
	5593926	WHEEL BALANCE WEIGHT, tape on (not illustrated). . .	A/R

# 2001 HUMMER PARTS CATALOG

## 13-40 ACCESSORIES

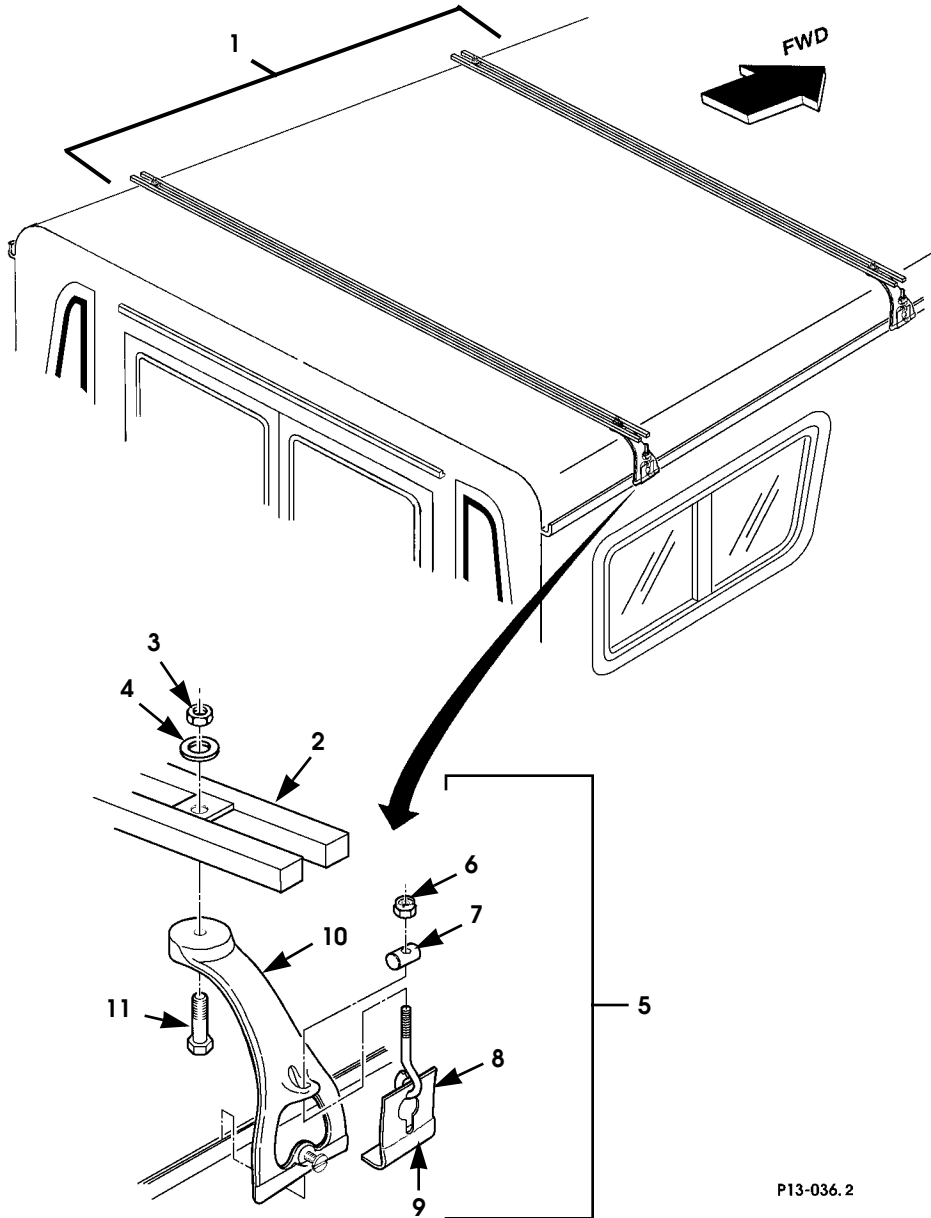

Figure 13-19. Universal Roof Mounting Rack Kit.

# 2001 HUMMER PARTS CATALOG

## ACCESSORIES 13-41

ITEM	PART NUMBER	DESCRIPTION	QTY
		<b>Figure 13-19.</b> <b>Universal Roof Mounting Rack Kit.</b>	
1	5744600	UNIVERSAL ROOF MOUNTING RACK KIT .....	1
2	5743258	•CROSSBAR .....	2
3	S.I.K.	•LOCKNUT, 3/8 - 16, nylon Insert. ....	4
4	S.I.K.	•WASHER, flat, 3/8 .....	4
5	5743250	•CLAMP ASSEMBLY .....	4
6	S.I.K.	••LOCKNUT, 1/4 - 20, nylon Insert .....	4
7	5743254	••SPACER, round, clamp .....	4
8	5743253	••CLIP, clamp. ....	4
9	5743252	••BOOT, rubber, clamp. ....	4
10	5743251	••YOKE, clamp .....	4
11	5743269	•BOLT, 3/8 - 16 x 2, Gr5, Phos. ....	4

# 2001 HUMMER PARTS CATALOG

## 13-42 ACCESSORIES

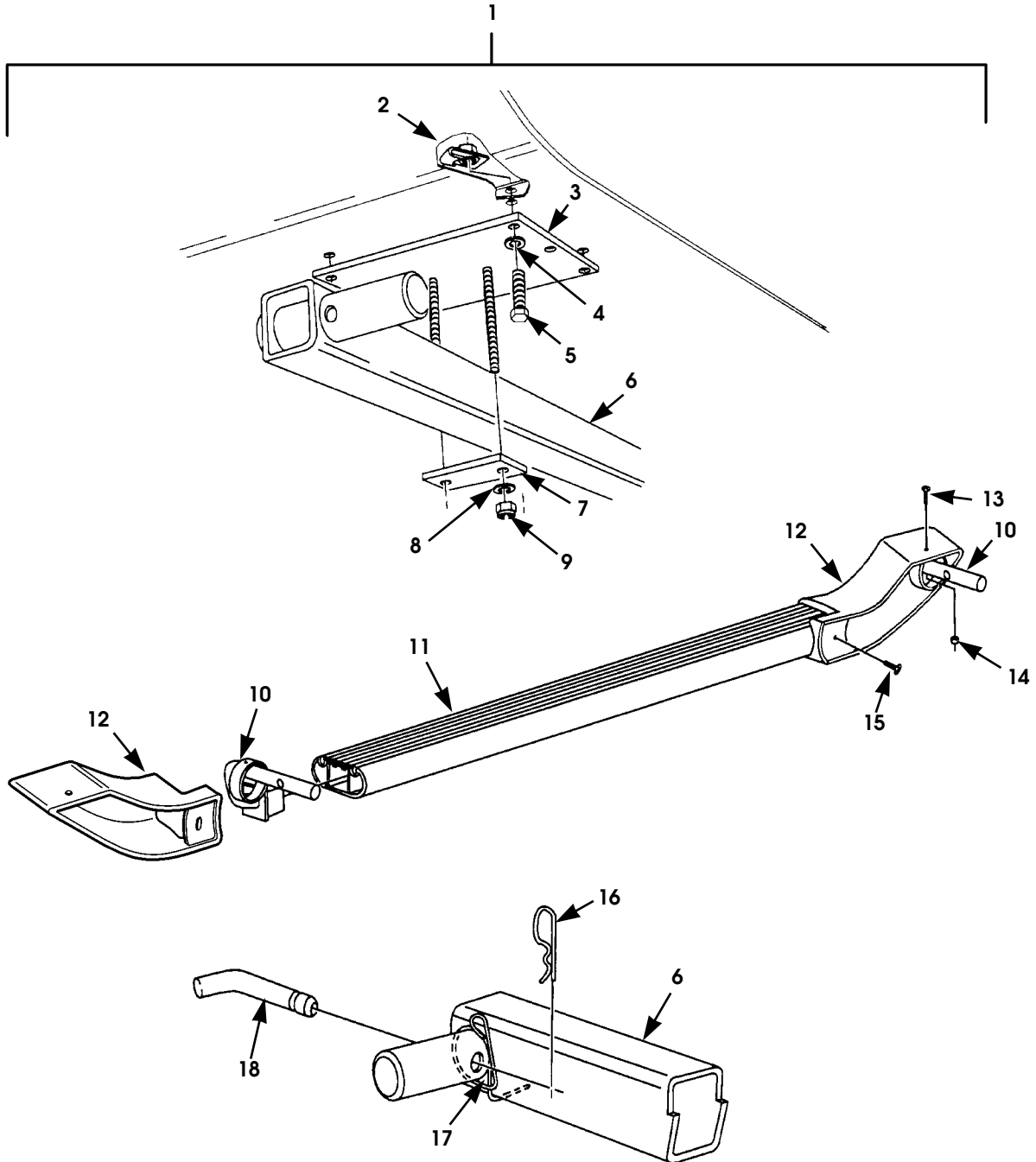

P13-037.1

Figure 13-20. Running Board Kit.

# 2001 HUMMER PARTS CATALOG

## ACCESSORIES 13-43

ITEM	PART NUMBER	DESCRIPTION	QTY
		<b>Figure 13-20. Running Board Kit.</b>	
1	5743446	KIT, running board . . . . .	1
2	6001283	•J-NUT, "U" type, 3/8 - 16 . . . . .	8
3	5743437	•MOUNTING bracket . . . . .	4
4	S.I.K.	•LOCKWASHER, med, 3/8, Phos . . . . .	12
5	S.I.K.	•BOLT, 3/8 - 16 x 1 1/4, Gr5, CAD . . . . .	12
6	5743441	•RECEIVER . . . . .	2
7	5743438	•PLATE, clamp . . . . .	6
8	S.I.K.	•WASHER, flat, 3/8, Type B . . . . .	8
9	S.I.K.	•LOCKNUT, 3/8 - 16, Gr5, ZN, nylon Insert . . . . .	8
10	5743439	•CURVED TUBE, with black plastic insert, lf, rr . . . . .	2
10	5743440	•CURVED TUBE, with orange plastic insert, rf, lr . . . . .	2
11	5743442	•RUNNING BOARD . . . . .	2
12	5743443	•END CAP, lf, rr . . . . .	2
12	5743444	•END CAP, rf, lr . . . . .	2
13	S.I.K.	•SCREW, truss head, #10 . . . . .	8
14	S.I.K.	•LOCKNUT, #10 - 24, nylon insert . . . . .	8
15	S.I.K.	•SCREW, tapping, slotted hex, flanged, 1/4 - 20 x 3/4 . . . . .	4
16	5743436	•CLIP . . . . .	4
17	5743434	•CLIP, spring . . . . .	4
18	5743435	•PIN . . . . .	4

# 2001 HUMMER PARTS CATALOG

## 13-44 ACCESSORIES

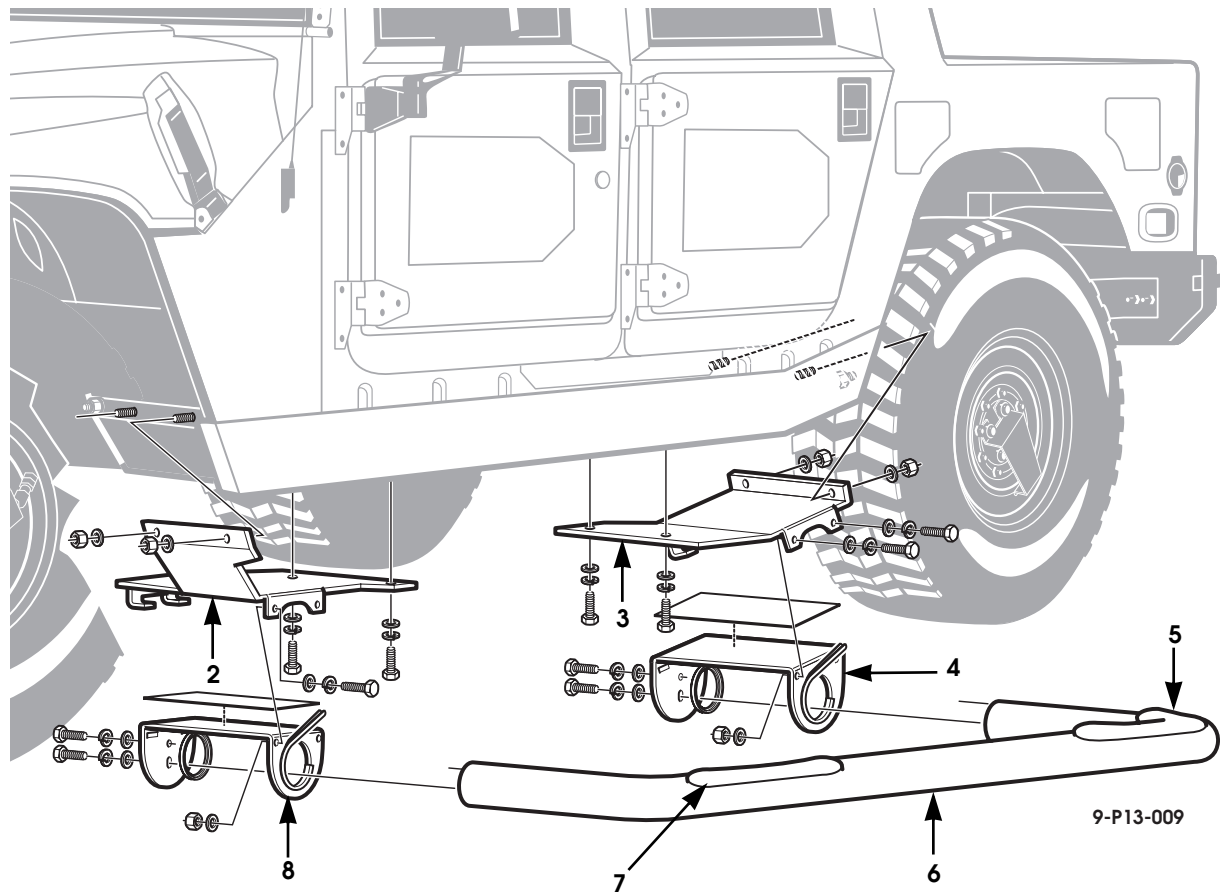

Note: Left side of vehicle shown.

Figure 13-21. Side Step Bars Kit.

# 2001 HUMMER PARTS CATALOG

## ACCESSORIES 13-45

ITEM	PART NUMBER	DESCRIPTION	QTY
		<b>Figure 13-21. Side Step Bars Kit.</b>	
1	5745049	KIT, side step bars, black textured . . . . .	1
1	5745050	KIT, side step bars, stainless steel . . . . .	1
2	5745088	•BRACKET, support, left front . . . . .	1
2	5745089	•BRACKET, support, right front . . . . .	1
3	5745090	•BRACKET, support, left rear . . . . .	1
3	5745091	•BRACKET, support, right rear . . . . .	1
4	5745097	•BRACKET, tube, left rear . . . . .	1
4	5745098	•BRACKET, tube, right rear . . . . .	1
5	5745047	•PAD, left rear step . . . . .	1
5	5745048	•PAD, right rear step . . . . .	1
6	5745084	•SIDE BAR, with step pad, left, black textured SEE NOTE 1	1
6	5745085	•SIDE BAR, with step pad, right, black textured SEE NOTE 1 . . . . .	1
6	5745086	•SIDE BAR, with step pad, left, stainless steel SEE NOTE 2	1
6	5745087	•SIDE BAR, with step pad, right, stainless steel SEE NOTE 2	1
7	5745046	•PAD, front step . . . . .	2
8	5745099	•BRACKET, tube, left and right front. . . . .	2
	S.I.K.	•HARDWARE PACKAGE . . . . .	1
		NOTE 1: PART OF KIT 5745049 ONLY.	
		NOTE 2: PART OF KIT 5745050 ONLY.	



# 2001 HUMMER PARTS CATALOG

## 13-46 ACCESSORIES

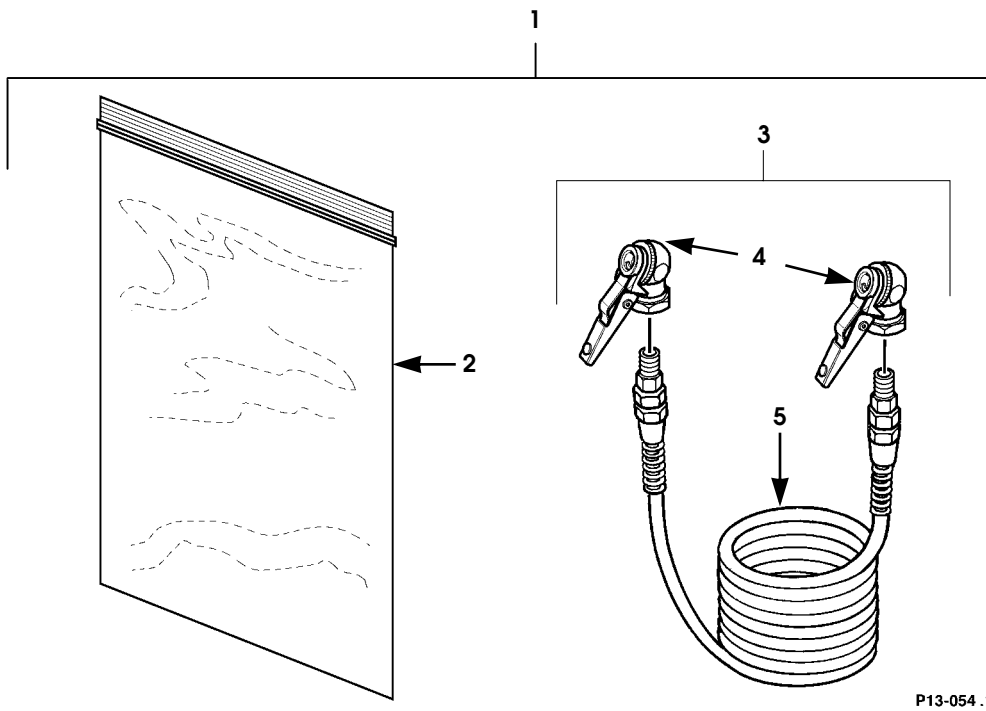

P13-054 .1

Figure 13-22. Auxiliary Air Hose Kit.

# 2001 HUMMER PARTS CATALOG

## ACCESSORIES 13-47

ITEM	PART NUMBER	DESCRIPTION	QTY
		<b>Figure 13-22. Auxiliary Air Hose Kit.</b>	
1	5743599	KIT, auxiliary air hose . . . . .	1
2	5743709	•BAG, CTIS hose storage, 12" x 12" plastic. . . . .	1
3	6004415	•HOSE ASSEMBLY, CTIS auxiliary air . . . . .	1
4	5745424	••CHUCK, clip-on . . . . .	2
5	6004416	••HOSE, auxiliary air . . . . .	1

# 2001 HUMMER PARTS CATALOG

## 13-48 ACCESSORIES

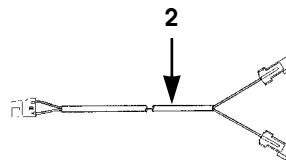
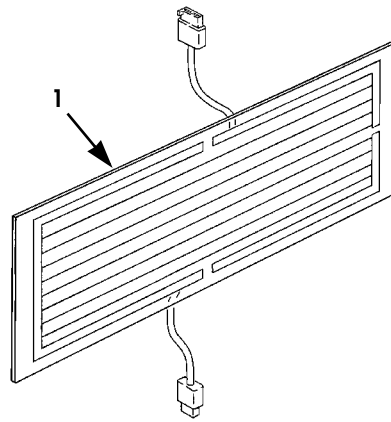

P13-055.1

*Figure 13-23. Rear Defroster.*

# 2001 HUMMER PARTS CATALOG

## ACCESSORIES 13-49

ITEM	PART NUMBER	DESCRIPTION	QTY
1	6005304	<b>Figure 13-23. Rear Defroster.</b> WINDOW ASSEMBLY, rear with defrost, sliding . . . . .	1
2	6005233	83, 89 HARNES, rear window defrost, sliding . . . . .	1

# 2001 HUMMER PARTS CATALOG

## 13-50 ACCESSORIES

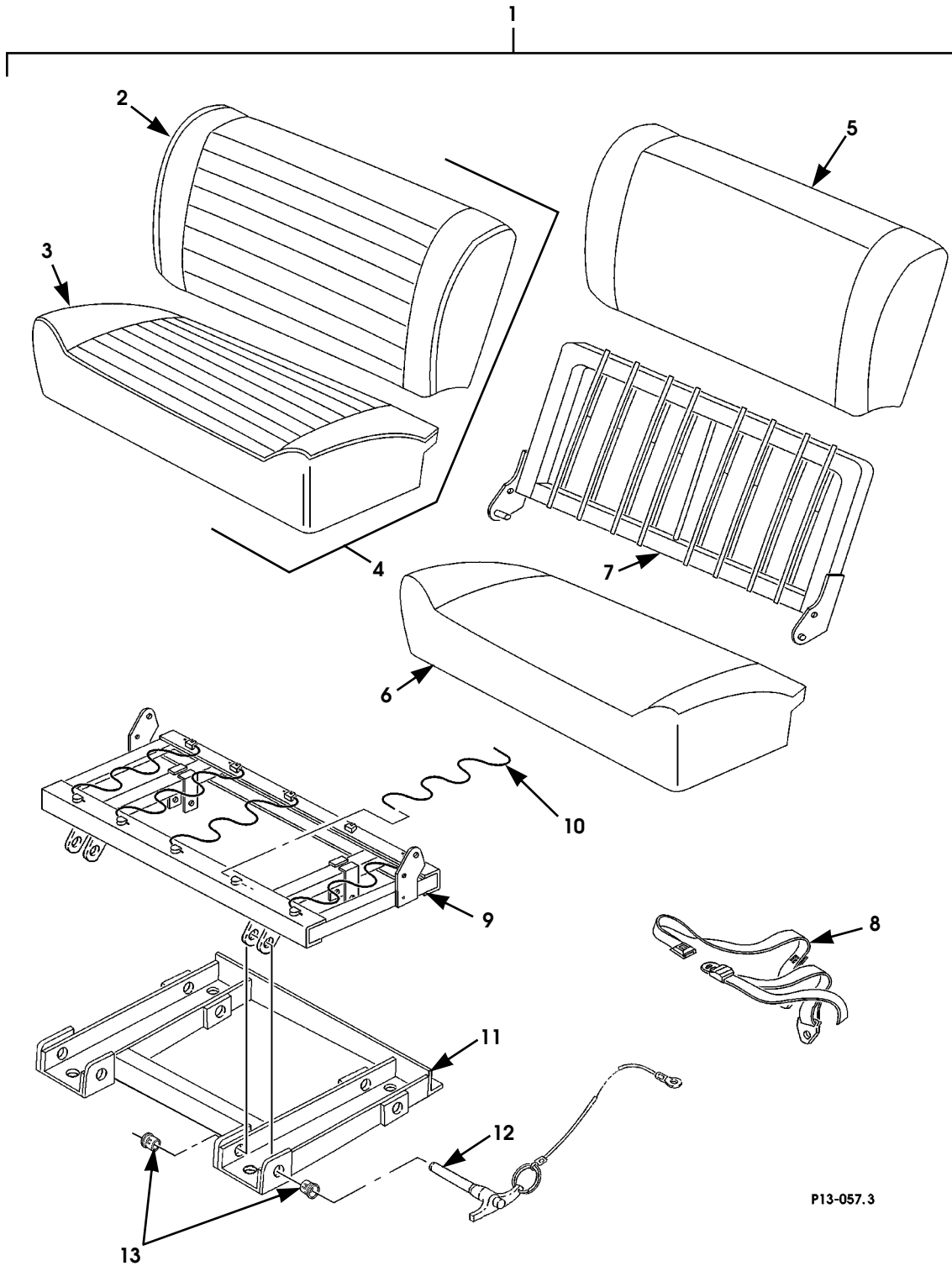

P13-057.3

Figure 13-24. Seat, Auxiliary.

# 2001 HUMMER PARTS CATALOG

## ACCESSORIES 13-51

ITEM	PART NUMBER	DESCRIPTION	QTY
		<b>Figure 13-24. Seat, Auxiliary.</b>	
1	6011493	SEAT, auxiliary, tan . . . . .	1
1	6011493G	SEAT, auxiliary, gray . . . . .	1
1	6009015B	SEAT, auxiliary, black vinyl . . . . .	1
2	5744858	•UPHOLSTERY, seat back, auxiliary seat, black. . . . .	1
3	5744857	•UPHOLSTERY, seat, auxiliary seat, black. . . . .	1
4	5745298	•UPHOLSTERY ASSEMBLY, seat & back, auxiliary seat, gray	1
4	5745297	•UPHOLSTERY ASSEMBLY, seat & back, auxiliary seat, tan	1
5	5744317	•FOAM, auxiliary seatback . . . . .	1
6	5744318	•FOAM, auxiliary seat, cushion . . . . .	1
7	5744314	•FRAME, auxiliary seatback, w/spring. . . . .	1
8	5744291	•SEAT BELT, auxiliary seat. . . . .	2
9	5744313	•FRAME, auxiliary seat w/spring . . . . .	1
10	5744316	••SPRING, auxiliary seat susp. . . . .	5
11	5744315	•FRAME, auxiliary seat mount . . . . .	1
12	5744292	••PIN AND LANYARD ASSEMBLY, auxiliary seat retainer	4
13	5744631	•BUSHING, auxiliary seat pin . . . . .	8

# 2001 HUMMER PARTS CATALOG

## 13-52 ACCESSORIES

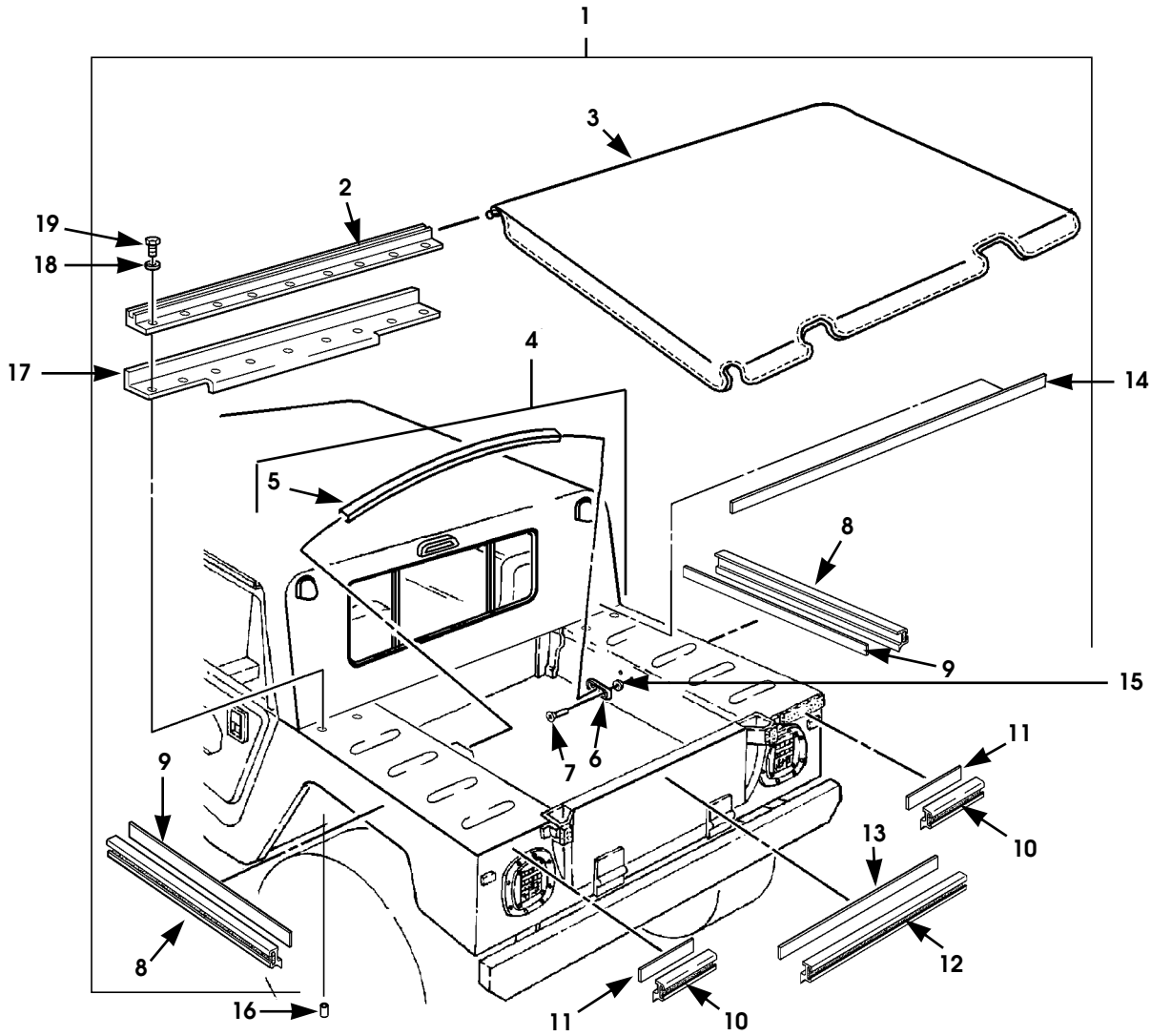

P13-053

NOTE: ITEMS 14 THROUGH 19 ARE  
NOT COMPONENTS OF ITEM 1.

Figure 13-25. Tonneau Cover 4-Door Hardtop.

# 2001 HUMMER PARTS CATALOG

## ACCESSORIES 13-53

ITEM	PART NUMBER	DESCRIPTION	QTY
		<b>Figure 13-25. Tonneau Cover 4-Door Hardtop.</b>	
1	6003663	KIT, tonneau cover, H/T, tan. . . . .	1
1	6004243	KIT, tonneau cover, H/T, black. . . . .	1
1	6004245	KIT, tonneau cover, H/T, white. . . . .	1
2	6003665	•EXTRUSION, tonneau cover . . . . .	1
3	6003664	•COVER, tonneau, tan, H/T . . . . .	1
3	6004244	•COVER, tonneau, black, H/T. . . . .	1
3	6004246	•COVER, tonneau, white, H/T. . . . .	1
4	5744425	•KIT, tonneau bow. . . . .	1
5	S.I.K.	••BOW, tonneau cover . . . . .	1
6	S.I.K.	••BRACKET, tonneau bow . . . . .	2
7	S.I.K.	••SCREW, phcr, #10 - 32 x 3/4. . . . .	4
8	6001670	•EXTRUSION, 41 in. PVC/velcro. . . . .	2
9	5745081	••VELCRO, 41" long . . . . .	2
10	6001671	•EXTRUSION, 9 in. PVC/velcro. . . . .	2
11	5745083	••VELCRO, 9" long . . . . .	2
12	6001669	•EXTRUSION, 43 in. PVC/velcro. . . . .	1
13	5745082	••VELCRO, 43" long . . . . .	1
14	6003848	SEAL, tonneau bracket . . . . .	1
15	N/S	NUT INSERT, rubber, #10 - 32 . . . . .	4
16	N/S	NUT INSERT, 1/4 - 20 . . . . .	9
17	6003844B2	MOUNTING BRACKET, tonneau extrusion . . . . .	1
18	N/S	LOCKWASHER, split, 1/4. . . . .	9
19	N/S	BOLT, 1/4 - 20 x 1, Gr8. . . . .	9



# 2001 HUMMER PARTS CATALOG

## 13-54 ACCESSORIES

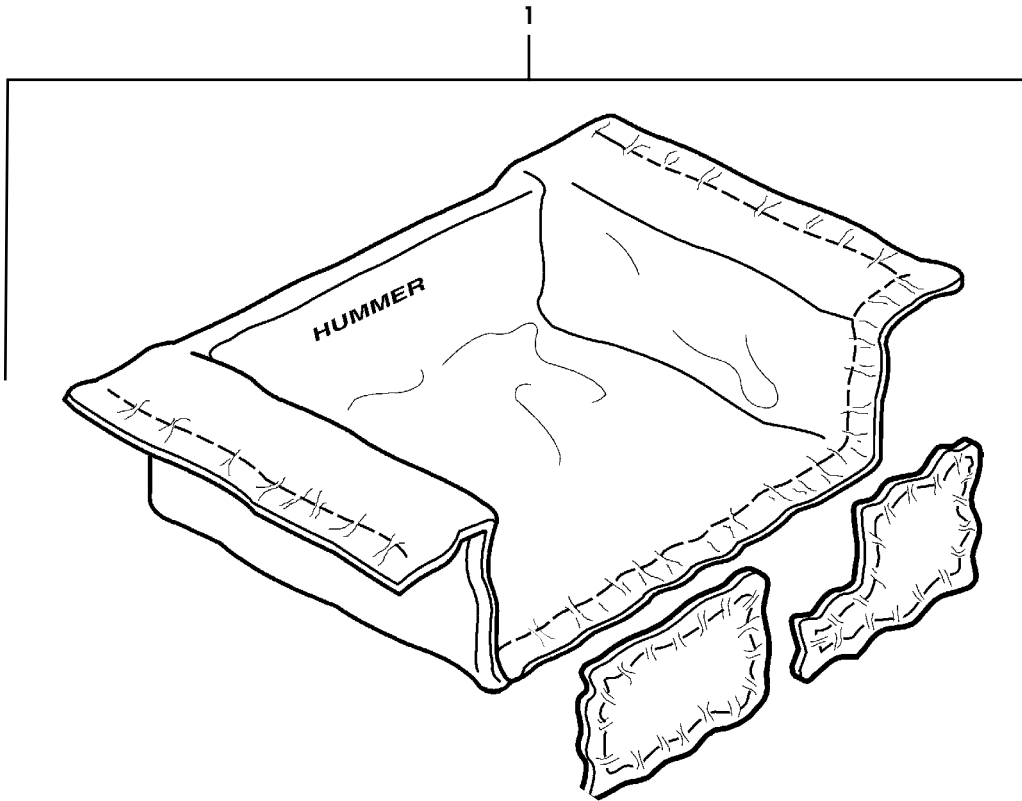

*Figure 13-26. Cargo Area Liner, Station Wagon.*

# 2001 HUMMER PARTS CATALOG

## ACCESSORIES 13-55

ITEM	PART NUMBER	DESCRIPTION	QTY
		<b>Figure 13-26. Cargo Area Liner, Station Wagon.</b>	
1	5744562	KIT, cargo liner and vertical doors, gray . . . . . 84	1
1	5744561	KIT, cargo liner and vertical doors, tan . . . . . 84	1

# 2001 HUMMER PARTS CATALOG

## 13-56 ACCESSORIES

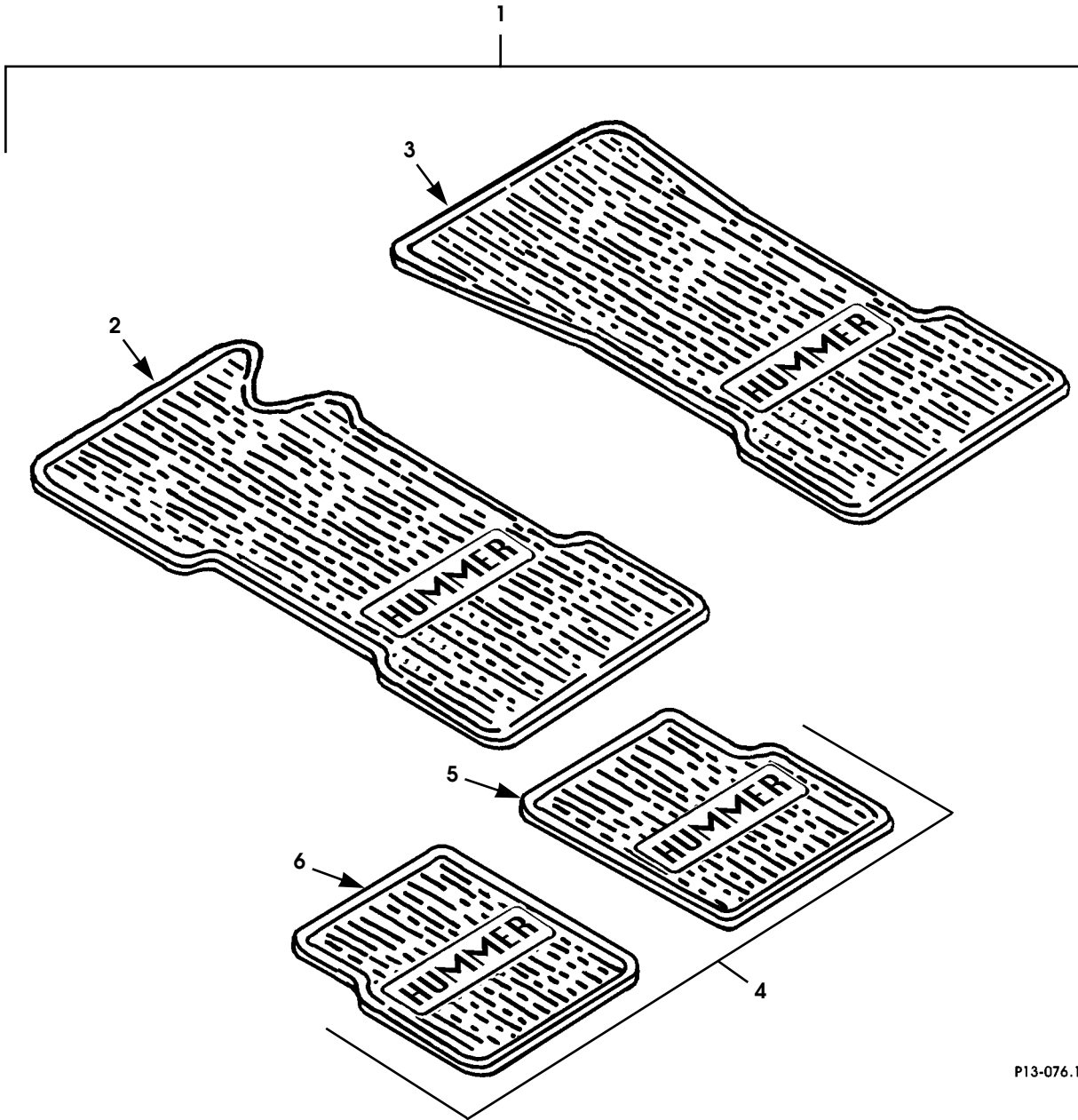

P13-076.1

Figure 13-27. Floor Mats

# 2001 HUMMER PARTS CATALOG

## ACCESSORIES 13-57

ITEM	PART NUMBER	DESCRIPTION	QTY
		<b>Figure 13-27. Floor Mats</b>	
1	5745036	KIT, floor mat, gray, front. . . . .	1
2	S.I.K.	•FLOOR MAT, L.H., front, gray . . . . .	1
3	S.I.K.	•FLOOR MAT, R.H., front, gray . . . . .	1
1	5745037	KIT, floor mat, brown, front . . . . .	1
2	S.I.K.	•FLOOR MAT, L.H., front, brown . . . . .	1
3	S.I.K.	•FLOOR MAT, R.H., front, brown . . . . .	1
1	5745213	KIT, floor mat, black rubber, front . . . . .	1
2	S.I.K.	•FLOOR MAT, L.H., front, black rubber . . . . .	1
3	S.I.K.	•FLOOR MAT, R.H., front, black rubber . . . . .	1
4	5745038	KIT, floor mat, gray, rear . . . . .	1
5	S.I.K.	•FLOOR MAT, L.H., rear, gray . . . . .	1
6	S.I.K.	•FLOOR MAT, R.H., rear, gray . . . . .	1
4	5745039	KIT, floor mat, brown, rear . . . . .	1
5	S.I.K.	•FLOOR MAT, L.H. rear, brown. . . . .	1
6	S.I.K.	•FLOOR MAT, R.H. rear, brown . . . . .	1
4	5745214	KIT, floor mat, black rubber, rear. . . . .	1
5	S.I.K.	•FLOOR MAT, L.H. rear, black rubber . . . . .	1
6	S.I.K.	•FLOOR MAT, R.H. rear, black rubber. . . . .	1

# 2001 HUMMER PARTS CATALOG

## 13-58 ACCESSORIES

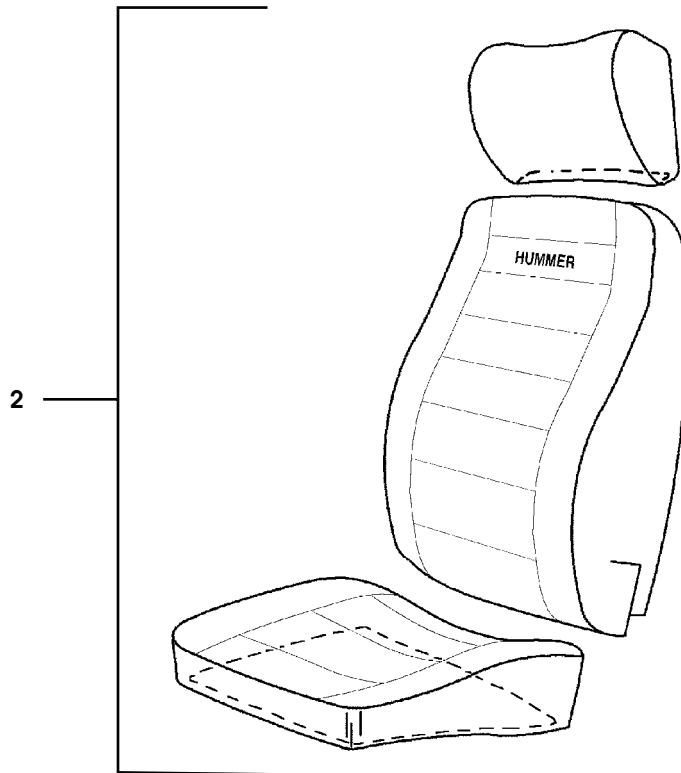
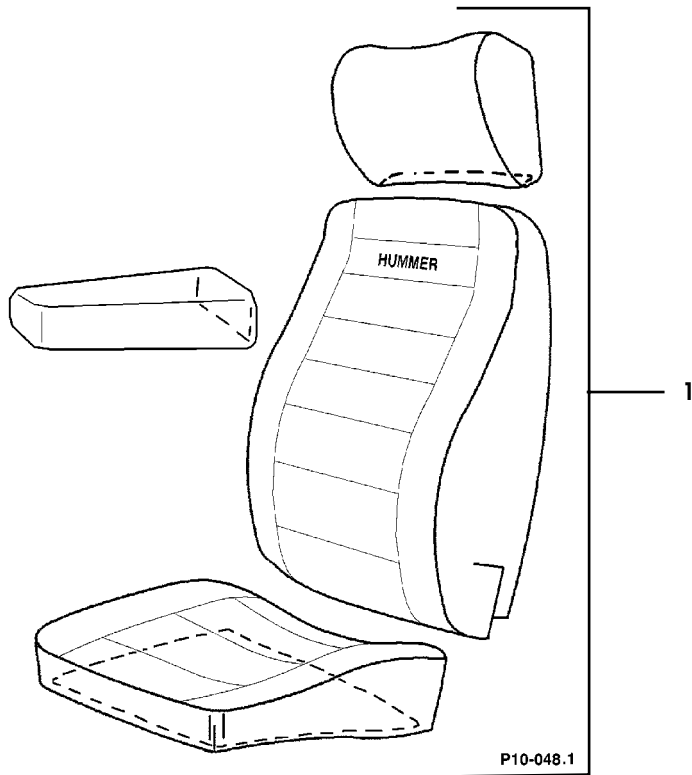

Figure 13-28. Seat Covers.

# 2001 HUMMER PARTS CATALOG

## ACCESSORIES 13-59

ITEM	PART NUMBER	DESCRIPTION	QTY
1	5744577	<b>Figure 13-28. Seat Covers.</b>	
	S.I.K.	KIT, protective seat cover, front, black . . . . .	1
	S.I.K.	•PROTECTIVE COVER, cushion . . . . .	1
	S.I.K.	•PROTECTIVE COVER, seat back . . . . .	1
	S.I.K.	•PROTECTIVE COVER, headrest . . . . .	1
2	S.I.K.	•PROTECTIVE COVER, armrest . . . . .	1
	5744578	KIT, protective seat cover, rear, black . . . . .	1
	S.I.K.	•PROTECTIVE COVER, cushion . . . . .	1
	S.I.K.	•PROTECTIVE COVER, seat back . . . . .	1
	S.I.K.	•PROTECTIVE COVER, headrest . . . . .	1
	5744579	STORAGE BAG, seat cover (not illustrated). . . . .	1

# 2001 HUMMER PARTS CATALOG

## 13-60 ACCESSORIES

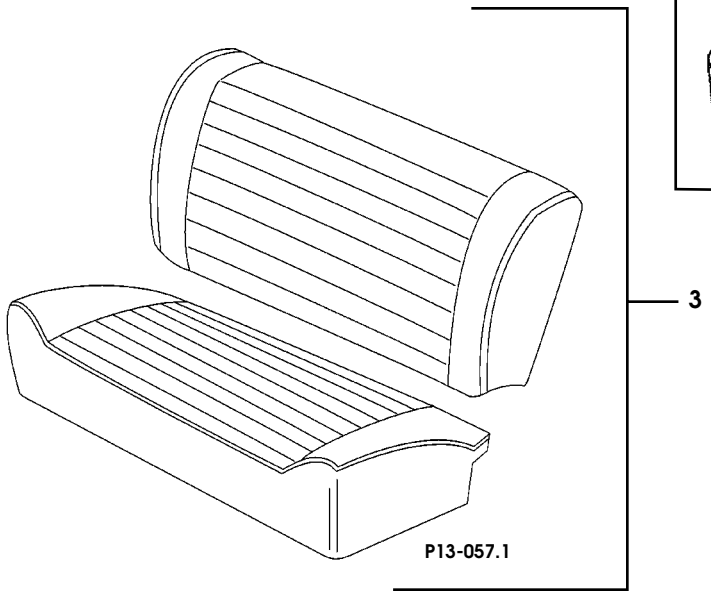
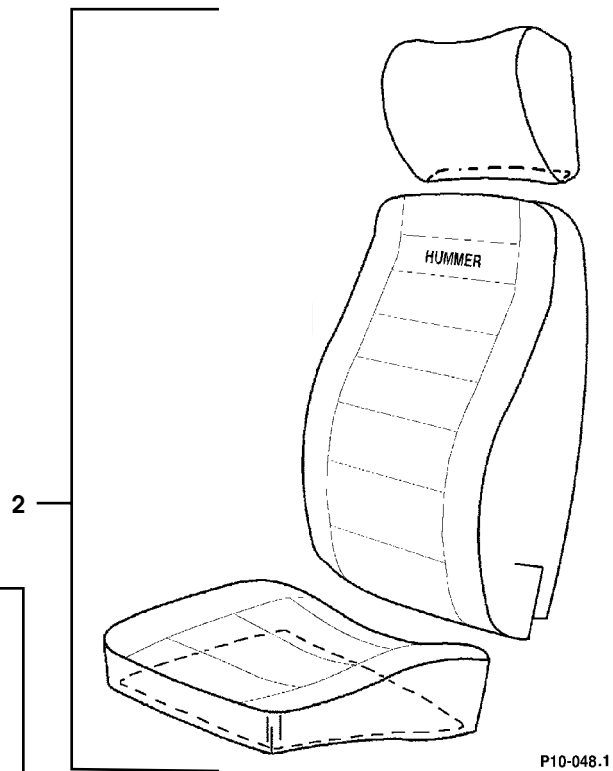
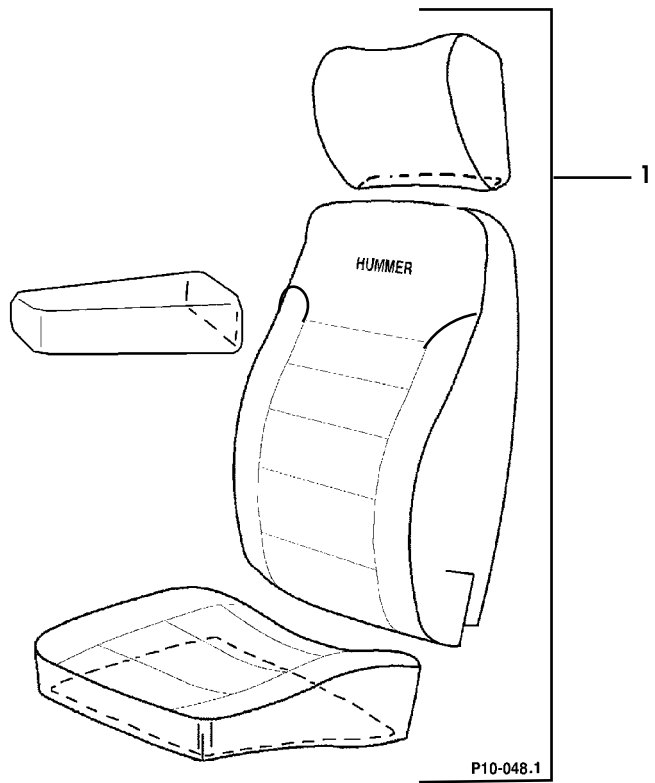

Figure 13-29. Leather Upholstery

# 2001 HUMMER PARTS CATALOG

## ACCESSORIES 13-61

ITEM	PART NUMBER	DESCRIPTION	QTY
		<b>Figure 13-29. Leather Upholstery</b>	
1	5744720	UPHOLSTERY, leather, R.H., front, tan. . . . .	1
1	5744721	UPHOLSTERY, leather, R.H., front, gray. . . . .	1
1	5744722	UPHOLSTERY, leather, L.H., front, tan. . . . .	1
1	5744723	UPHOLSTERY, leather, L.H., front, gray . . . . .	1
2	5744724	UPHOLSTERY, leather, rear, tan . . . . .	2
2	5744725	UPHOLSTERY, leather, rear, gray . . . . .	2
3	5745023	UPHOLSTERY, leather, auxiliary seat, tan . . . . .	1
3	5745022	UPHOLSTERY, leather, auxiliary seat, gray . . . . .	1



# 2001 HUMMER PARTS CATALOG

## 13-62 ACCESSORIES

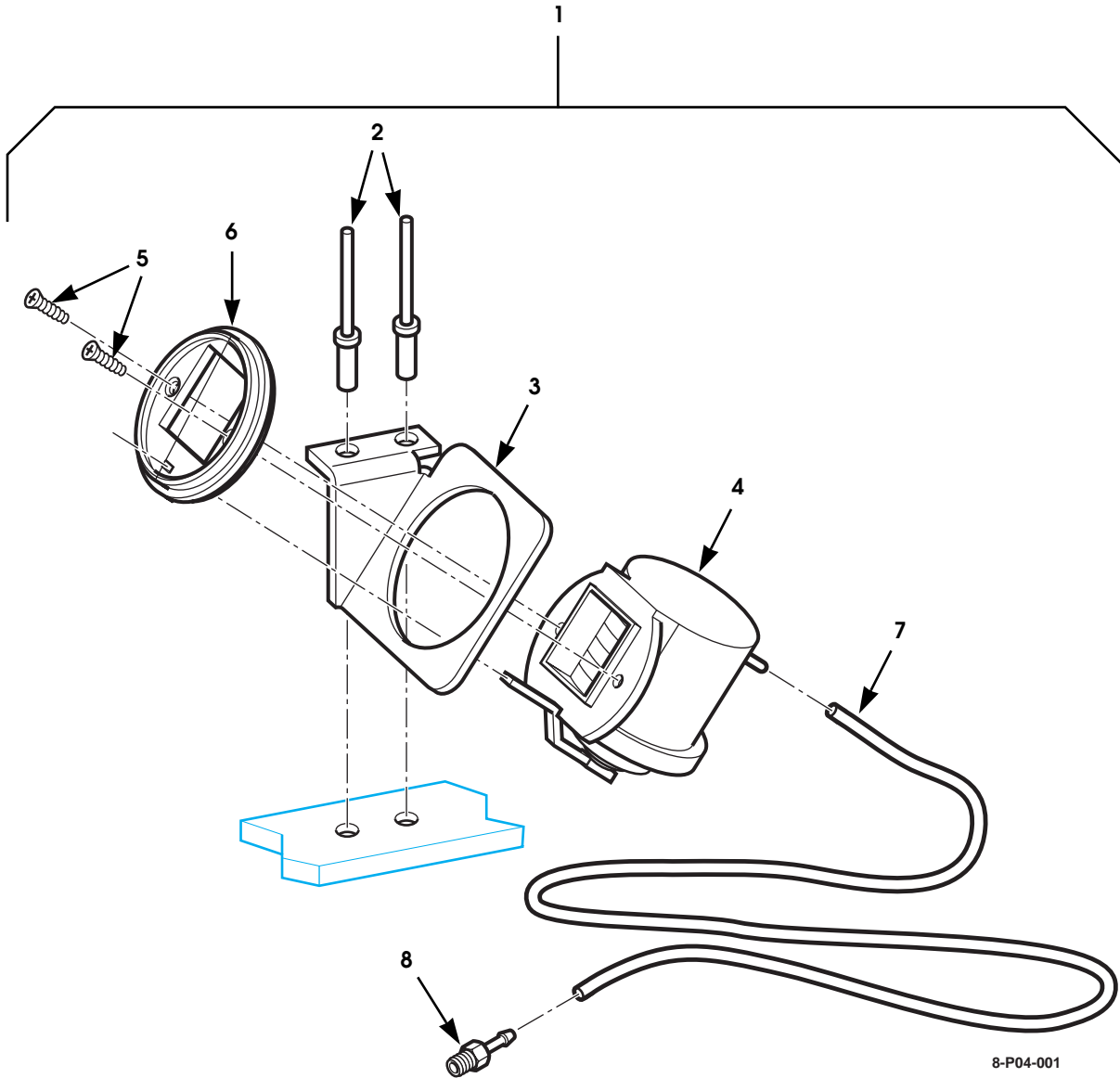

Figure 13-30. Air Filter Restriction Gauge Kit

# 2001 HUMMER PARTS CATALOG

## ACCESSORIES 13-63

ITEM	PART NUMBER	DESCRIPTION	QTY
		<b>Figure 13-30. Air Filter Restriction Gauge Kit</b>	
1	5744872	KIT, air filter restriction gauge . . . . .	1
2	S.I.K.	•RIVET, 1/8" x 5/16" . . . . .	2
3	6002004	•BRACKET, air filter restriction gauge mounting . . . . .	1
4	6001933	•AIR FILTER RESTRICTION GAUGE . . . . .	1
5	S.I.K.	••SCREW, air filter restriction gauge bezel . . . . .	2
6	S.I.K.	••BEZEL, air filter restriction gauge . . . . .	1
7	S.I.K.	•HOSE, 1/4" O.D. x 24" long . . . . .	1
8	12339978	•HOSE BARB, 1/8" - 1/8" NPT . . . . .	1

# 2001 HUMMER PARTS CATALOG

## 13-64 ACCESSORIES

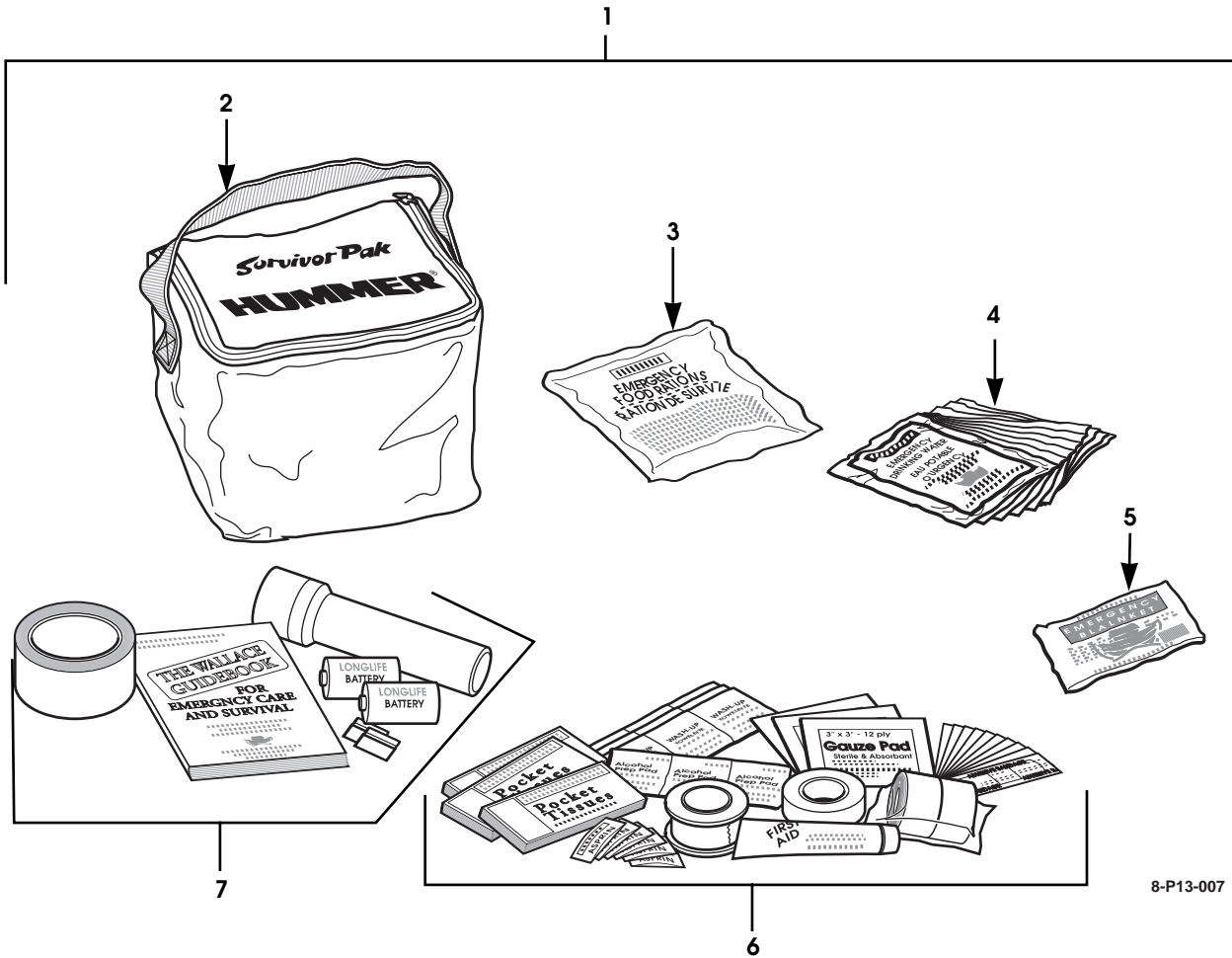

Figure 13-31. Traveler's Survival Kit

# 2001 HUMMER PARTS CATALOG

## ACCESSORIES 13-65

ITEM	PART NUMBER	DESCRIPTION	QTY
		<b>Figure 13-31. Traveler's Survival Kit</b>	
1	5744903	KIT, traveler's survival . . . . .	1
2	5744996	•BAG. . . . .	1
3	S.I.K.	•FOOD PACKET, 3-day supply . . . . .	1
4	S.I.K.	•WATER PACKETS, 3-day supply . . . . .	12
5	S.I.K.	•SPACE BLANKET . . . . .	1
6	S.I.K.	•MEDICAL SUPPLIES PACKAGE . . . . .	1
7	S.I.K.	•GENERAL SUPPLIES PACKAGE . . . . .	1

# 2001 HUMMER PARTS CATALOG

## 13-66 ACCESSORIES

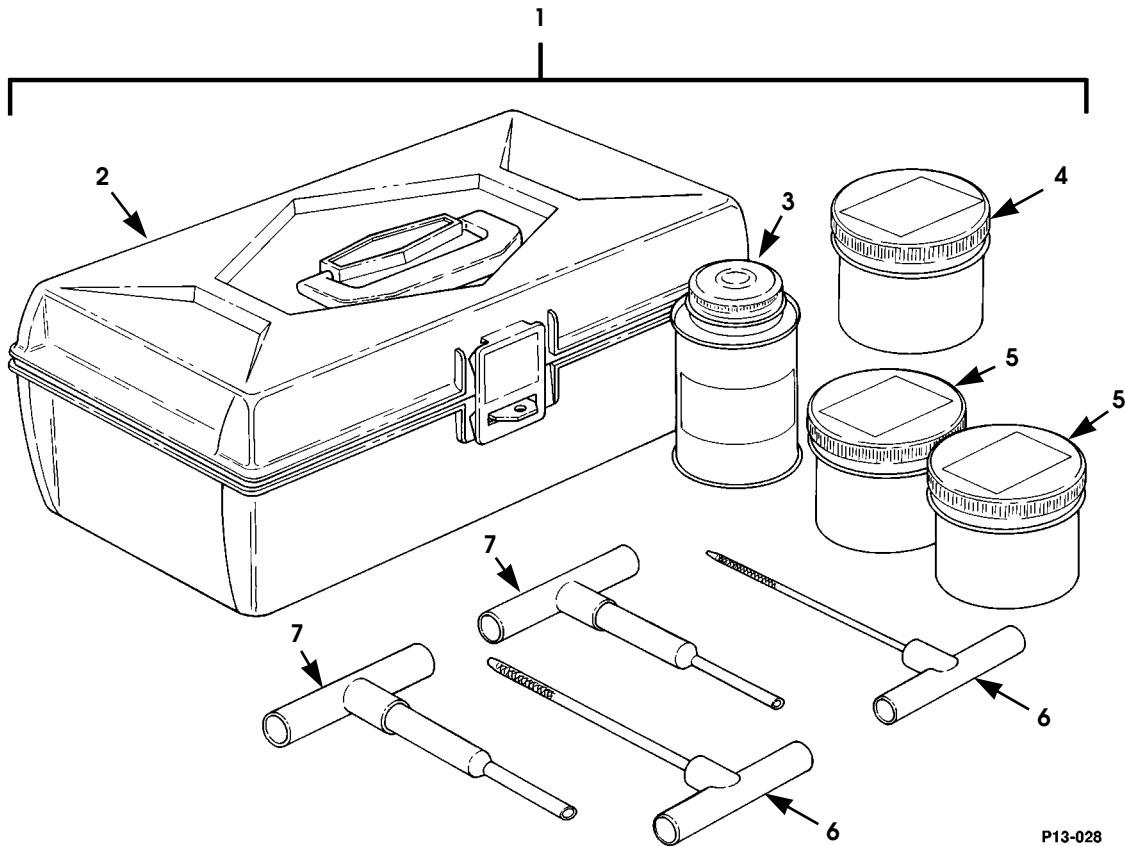

Figure 13-32. Tire (Tubeless) Repair Kit, External.

# 2001 HUMMER PARTS CATALOG

## ACCESSORIES 13-67

ITEM	PART NUMBER	DESCRIPTION	QTY
		<b>Figure 13-32.</b> <b>Tire (Tubeless) Repair Kit, External.</b>	
1	5710215	KIT, external tubeless tire repair .....	1
2	5742542	•TOOLBOX, .....	1
3	5742537	•FLUID, chemical vulcanizing (1/2 pint) .....	1
4	5742538	•PLUG, large tire .....	15
5	5742539	•PLUG, small tire .....	30
6	5742540	•RASP .....	2
7	5742541	•TOOL, plug insert .....	2

# 2001 HUMMER PARTS CATALOG

## 13-68 ACCESSORIES

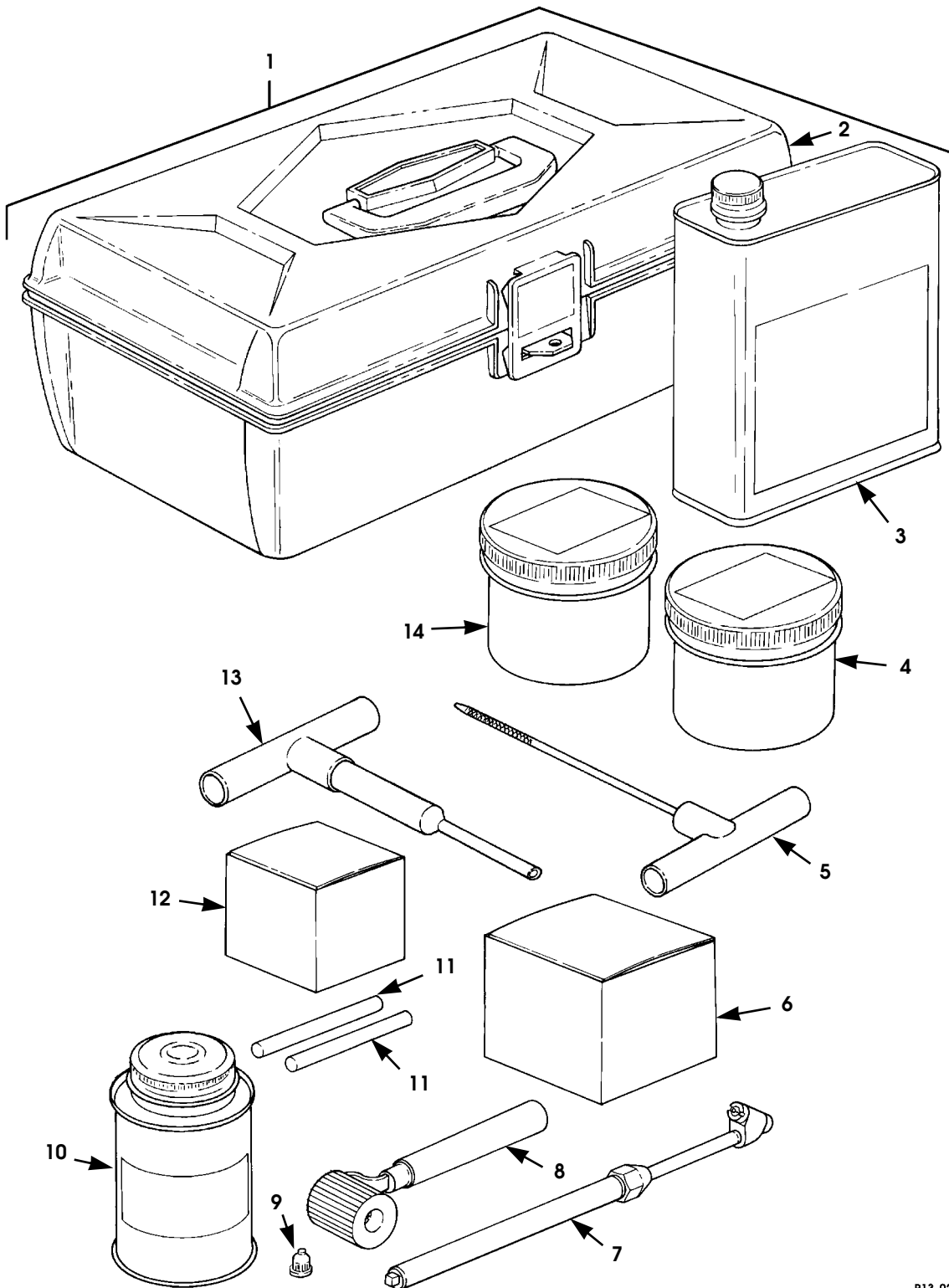

P13-029

Figure 13-33. Tire (Tubeless) Repair Kit, Internal.

# 2001 HUMMER PARTS CATALOG

## ACCESSORIES 13-69

ITEM	PART NUMBER	DESCRIPTION	QTY
		<b>Figure 13-33.</b> <b>Tire (Tubeless) Repair Kit, Internal.</b>	
1	5710216	KIT, internal tubeless tire repair . . . . .	1
2	5713347	•TOOLBOX . . . . .	1
3	5713351	•CLEANER (32 ounce) . . . . .	1
4	5742539	•PLUG, small . . . . .	15
5	5742540	•RASP . . . . .	1
6	5713341	•PATCH (R-20) . . . . .	20
7	5714148	•GAUGE, tire pressure . . . . .	1
8	5713340	•STITCHER, patch roll . . . . .	1
9	5714149	•CAP, valve stem . . . . .	20
10	5713343	•CEMENT (8 ounce) . . . . .	2
11	5714147	•PENCIL, yellow chalk . . . . .	2
12	5713339	•PATCH (R-12) . . . . .	20
13	5712541	•TOOL, plug insert . . . . .	1
14	5742538	•PLUG, large . . . . .	15
	5713342	•SCRAPER (not illustrated) . . . . .	1



# 2001 HUMMER PARTS CATALOG

## 13-70 ACCESSORIES

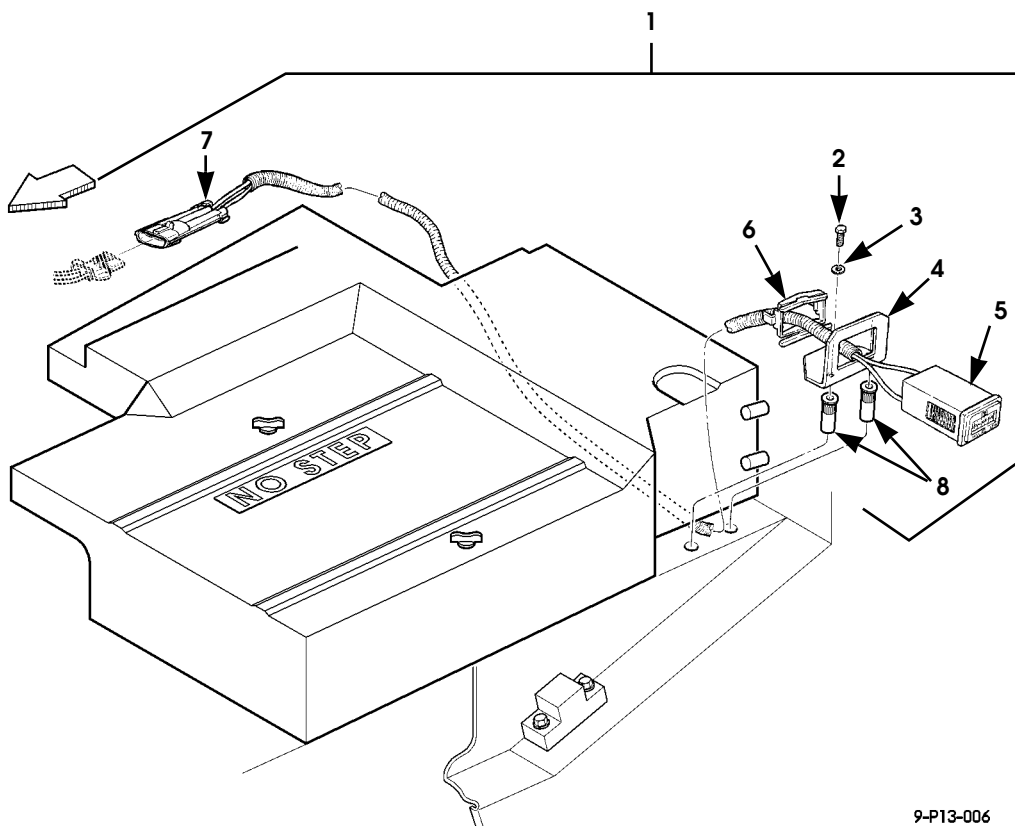

9-P13-006

Figure 13-34. Hourmeter Kit

# 2001 HUMMER PARTS CATALOG

## ACCESSORIES 13-71

ITEM	PART NUMBER	DESCRIPTION	QTY
		<b>Figure 13-34. Hourmeter Kit</b>	
1	5744869	KIT, hourmeter .....	1
2	S.I.K.	•BOLT, #10 - 24 x 5/8, hourmeter .....	2
3	S.I.K.	•WASHER, flat, #10 .....	2
4	6008033	•BRACKET, hourmeter mounting .....	1
5	6008032	•HOURMETER ASSEMBLY .....	1
6	S.I.A.	••SPRING CLIP. ....	1
7	6008196	••CONNECTOR, female, hourmeter .....	1
8	S.I.K.	•NUT INSERT, #10 - 24 .....	2

# 2001 HUMMER PARTS CATALOG

## 13-72 ACCESSORIES

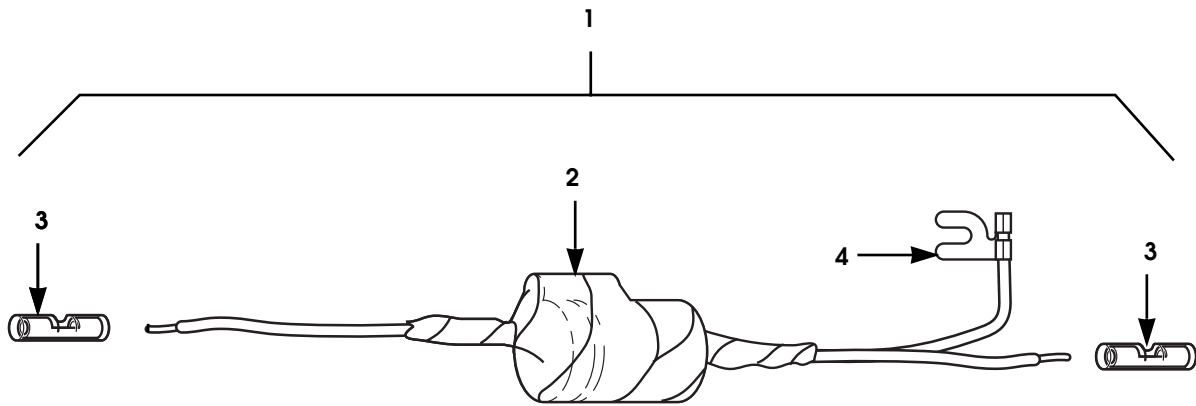

8-P13-009

*Figure 13-35. Radio Noise Suppression Filter Kit*

# 2001 HUMMER PARTS CATALOG

## ACCESSORIES 13-73

ITEM	PART NUMBER	DESCRIPTION	QTY
		<b>Figure 13-35. Radio Noise Suppression Filter Kit</b>	
1	5744279	FILTER KIT, radio noise suppression . . . . .	1
2	S.I.K.	•FILTER, radio noise suppression . . . . .	1
3	S.I.K.	•CONNECTOR, butt. . . . .	2
4	S.I.K.	•F-TERMINAL. . . . .	1

# 2001 HUMMER PARTS CATALOG

## 13-74 ACCESSORIES

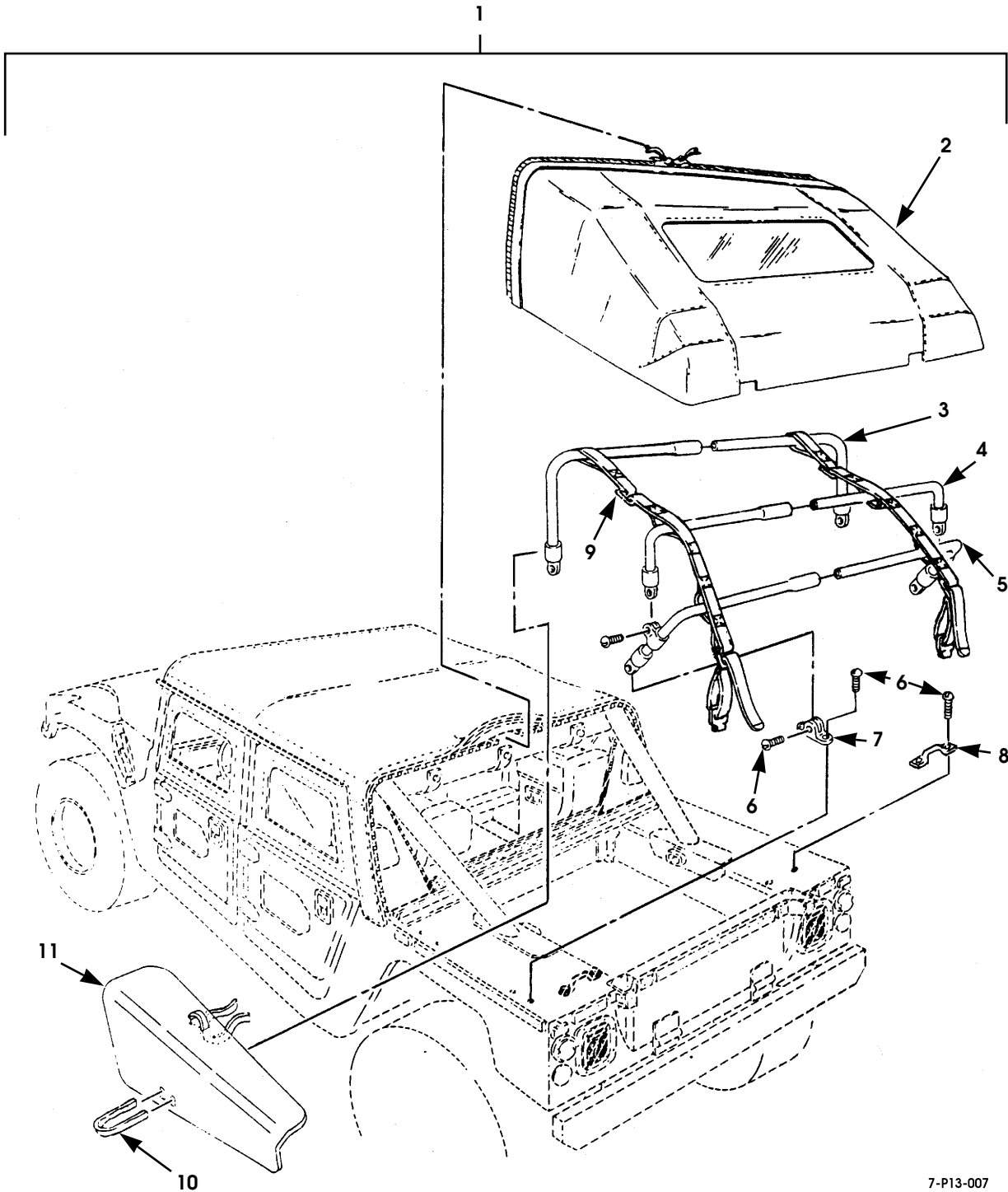

7-P13-007

*Figure 13-36. Slant-Back (Soft) Kit  
(Four-Door Soft Top)*

# 2001 HUMMER PARTS CATALOG

## ACCESSORIES 13-75

ITEM	PART NUMBER	DESCRIPTION	QTY
		<b>Figure 13-36. Slant-Back (Soft) Kit (Four-Door Soft Top)</b>	
1	5742961	KIT, soft top slant-back, tan. . . . .	1
		90	
1	5744851	KIT, soft top slant-back, black. . . . .	1
		90	
1	5744852	KIT, soft top slant-back, white. . . . .	1
		90	
2	6001747	•COVER ASSEMBLY, tan. . . . .	1
2	5744757	•COVER ASSEMBLY, black. . . . .	1
2	5744758	•COVER ASSEMBLY, white. . . . .	1
3	6001748	•BOW ASSEMBLY, front. . . . .	1
4	6001749	•BOW ASSEMBLY, middle. . . . .	1
5	6001750	•BOW ASSEMBLY, rear. . . . .	1
6	S.i.K.	•SCREW, #10 - 32 x 3/4. . . . .	16
7	6001717	•BRACKET, hinge. . . . .	4
8	6001719	•FOOTMAN LOOP. . . . .	2
9	5743708	•LOOP, extended webbing. . . . .	2
10	S.I.K.	•STRAP, velcro. . . . .	4
11	6002519	•FORMER, slant-back, L.H. . . . .	1
11	6002520	•FORMER, slant-back, R.H. . . . .	1

# 2001 HUMMER PARTS CATALOG

## 13-76 ACCESSORIES

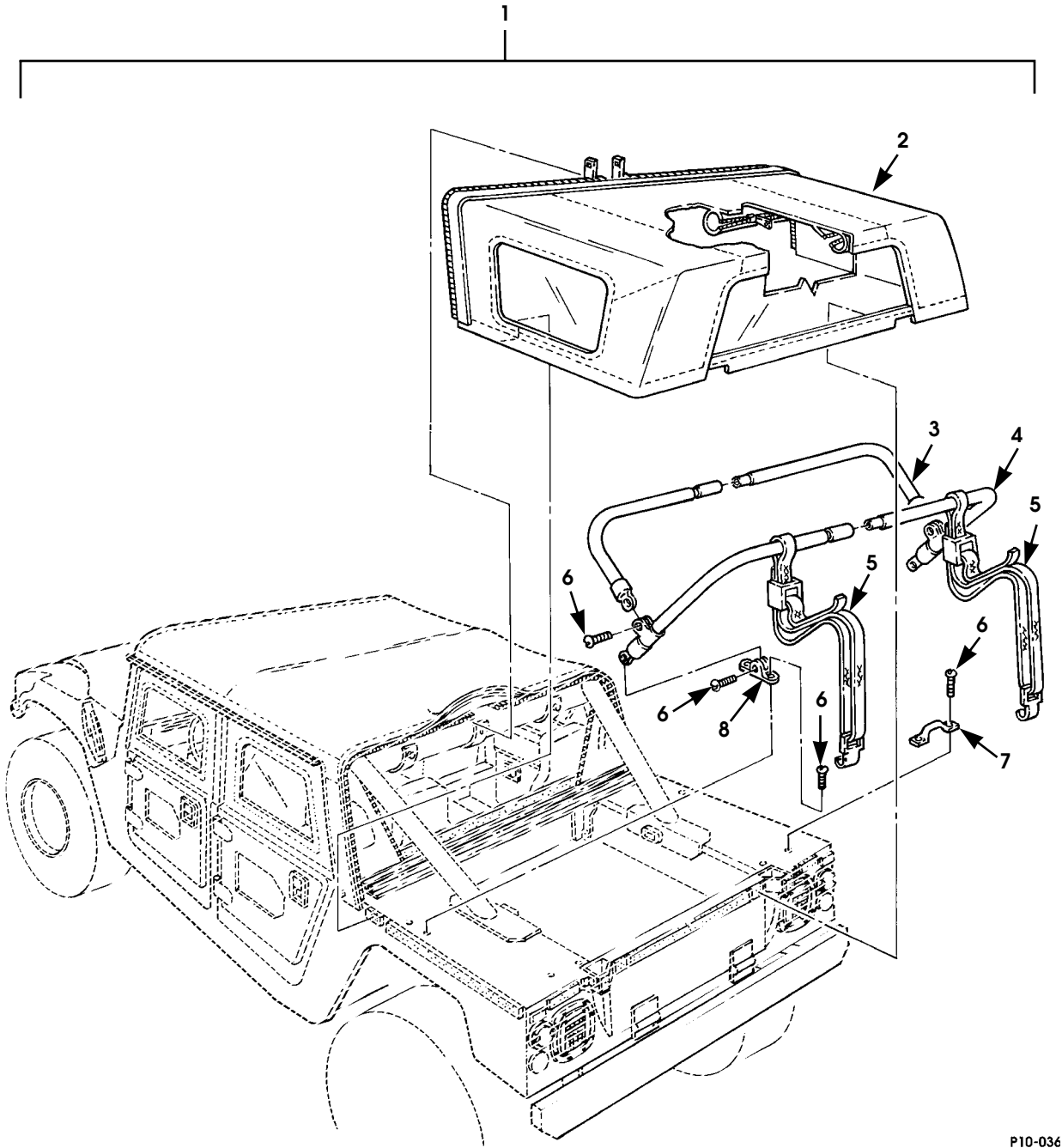

P10-036

Figure 13-37. Soft Square Back Kit, Model 90

# 2001 HUMMER PARTS CATALOG

## ACCESSORIES 13-77

ITEM	PART NUMBER	DESCRIPTION	QTY
		<b>Figure 13-37.</b> <b>Soft Square Back Kit, Model 90</b>	
1	5742960	KIT, soft top, tan . . . . .	1
1	6004208	KIT, soft top, white . . . . .	1
1	6004069	KIT, soft top, black . . . . .	1
2	6001714	•COVER ASSEMBLY, soft top, tan . . . . .	1
2	6004209	•COVER ASSEMBLY, soft top, white . . . . .	1
2	6004070	•COVER ASSEMBLY, soft top, black . . . . .	1
3	6001715	•BOW ASSEMBLY, front . . . . .	1
4	6001716	•BOW ASSEMBLY, rear . . . . .	1
5	6001718	•LOOP, extended webbing . . . . .	2
6	S.I.A.	•SCREW, #10 - 32 x 3/4 . . . . .	12
7	6001719	•FOOTMAN LOOP . . . . .	2
8	6001717	•BRACKET, hinge . . . . .	2
		NOTE : VELCRO STRIP FOR RETAINING THE BOTTOM EDGE IS NOT INCLUDED. SEE FIGURE 10-32 FOR THESE PARTS.	



# 2001 HUMMER PARTS CATALOG

## 13-78 ACCESSORIES

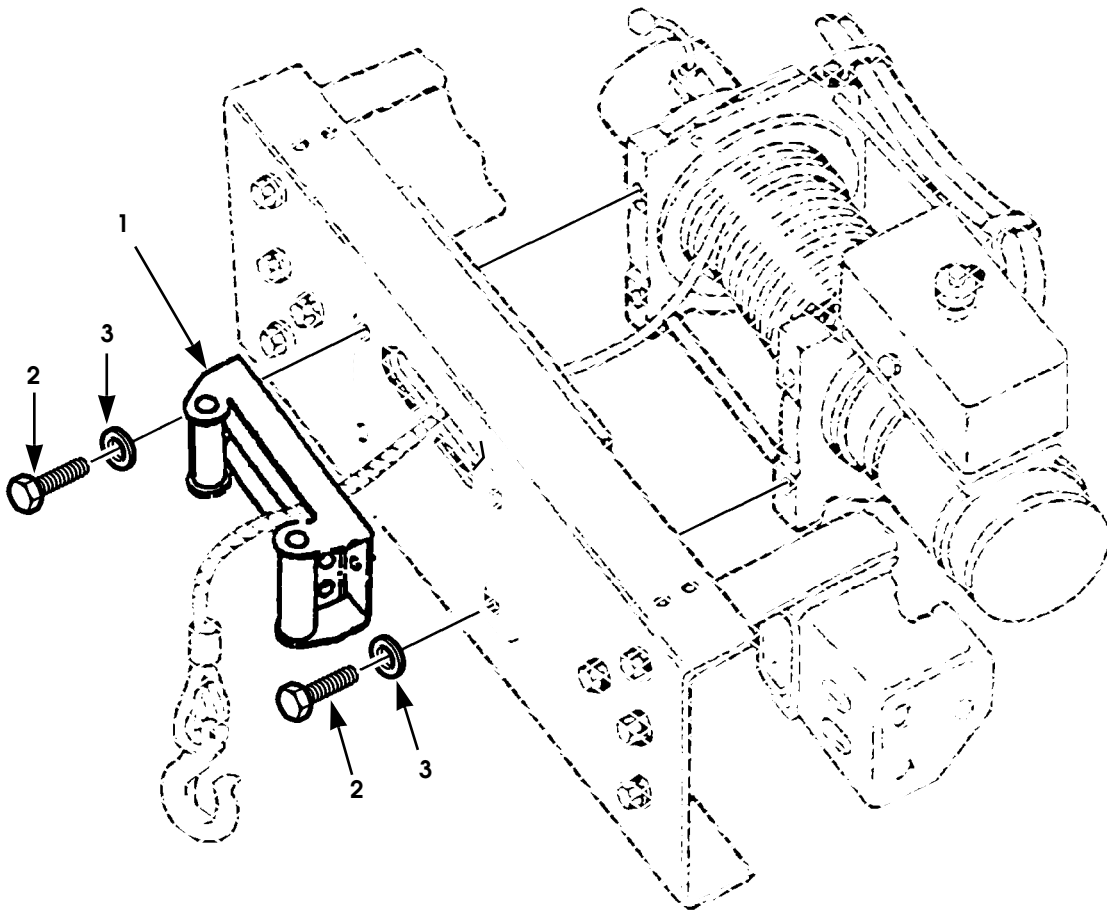

7-S13-001.1

Figure 13-38. Winch Roller Fairlead

# 2001 HUMMER PARTS CATALOG

## ACCESSORIES 13-79

ITEM	PART NUMBER	DESCRIPTION	QTY
		<b>Figure 13-38. Winch Roller Fairlead</b>	
1	5744714	WINCH ROLLER FAIRLEAD, black .....	1
1	5744715	WINCH ROLLER FAIRLEAD, chrome .....	1
2	N/S	BOLT, M12 - 1.75 x 35 .....	2
3	N/S	WASHER, flat, hard, M12 .....	2

# 2001 HUMMER PARTS CATALOG

## 13-80 ACCESSORIES

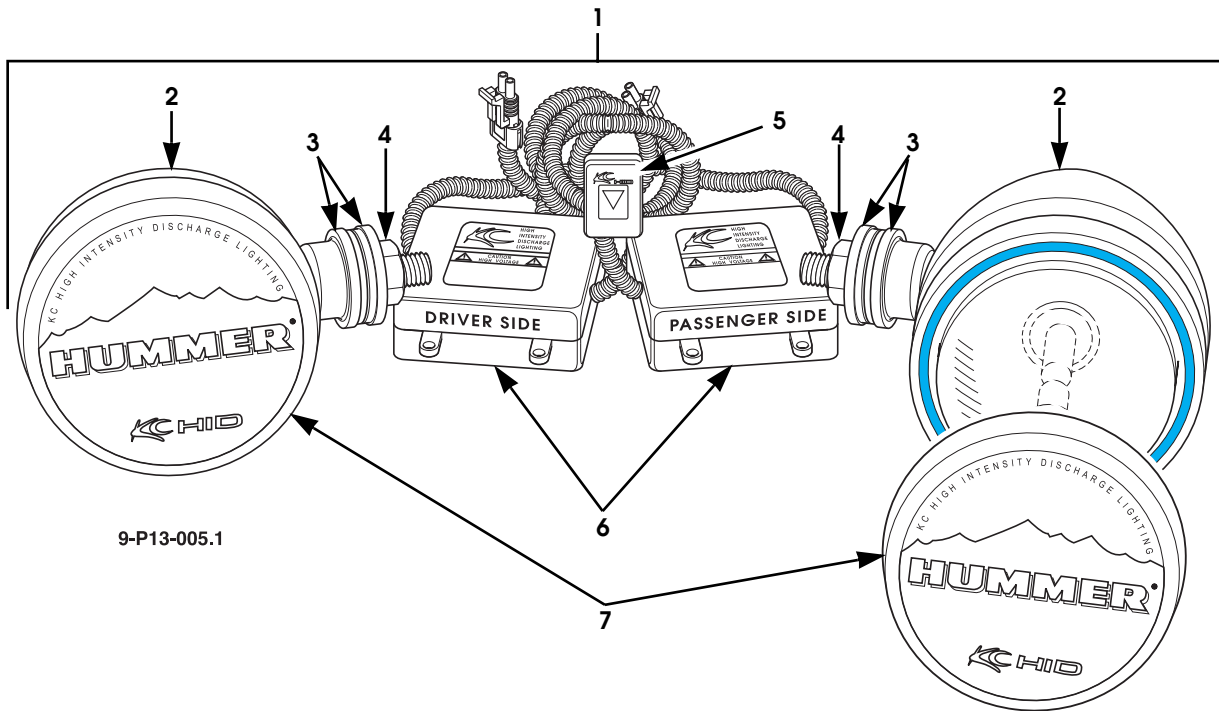

Figure 13-39. Off-Road Light Kit

# 2001 HUMMER PARTS CATALOG

## ACCESSORIES 13-81

ITEM	PART NUMBER	DESCRIPTION	QTY
		<b>Figure 13-39.</b> <b>Off-Road Light Kit</b>	
1	5745027	KIT, off-road light, black . . . . .	1
1	5745028	KIT, off-road light, stainless steel . . . . .	1
2	S.I.A.	•LAMP, high intensity discharge (HID), black . . . . .	2
2	S.I.A.	•LAMP, high intensity discharge (HID), stainless steel. . . . .	2
3	S.I.A.	•WASHER, HID mounting. . . . .	4
4	S.I.A.	•NUT, HID mounting. . . . .	4
5	S.I.A.	•RELAY . . . . .	1
6	S.I.A.	•BALLAST . . . . .	2
7	5745006	•COVER, lamp, HID . . . . .	2
	5745103	•SWITCH (not illustrated) . . . . .	1
	S.I.A.	NUT (not illustrated) . . . . .	1
	S.I.A.	LOCKWASHER (not illustrated) . . . . .	1
	S.I.A.	BOLT (not illustrated) . . . . .	1

# 2001 HUMMER PARTS CATALOG

## 13-82 ACCESSORIES

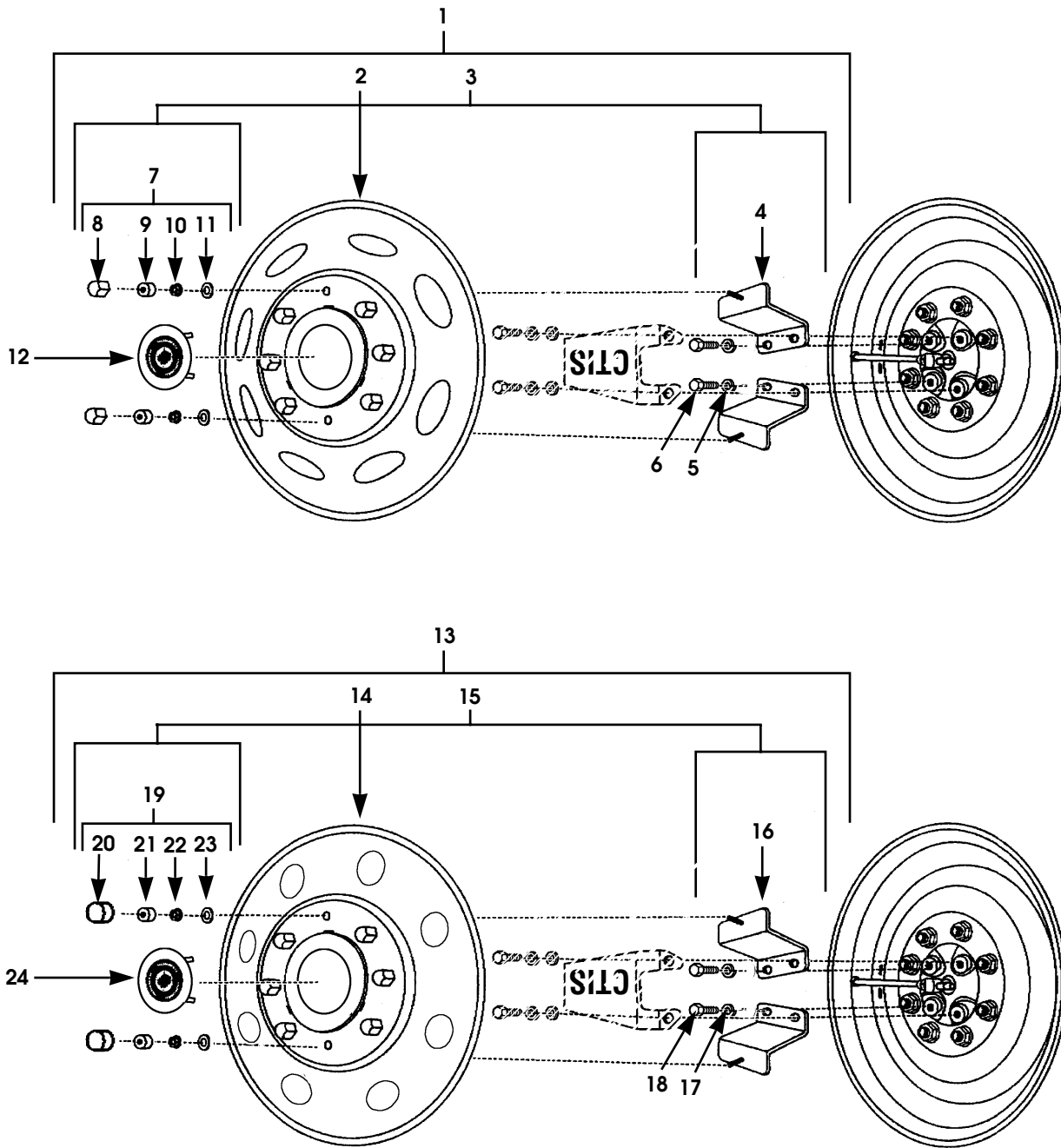

8-P13-001.1

Figure 13-40. Wheel Cover Kit, Stainless Steel.

# 2001 HUMMER PARTS CATALOG

## ACCESSORIES 13-83

ITEM	PART NUMBER	DESCRIPTION	QTY
		<b>Figure 13-40.</b> <b>Wheel Cover Kit, Stainless Steel.</b>	
1	5744658	KIT, stainless steel wheel cover with or without CTIS . . . SEE NOTE 1 . . . . .	1
2	5744921	•WHEEL COVER, stainless steel. . . . .	4
3	5744920	•KIT, wheel cover mounting bracket. . . . .	1
4	S.I.K.	••BRACKET, wheel cover hub . . . . .	2
5	S.I.K.	••LOCKWASHER, 7/16. . . . .	4
6	S.I.K.	••BOLT, 7/16 - 14 x 3/4, wheel cover bracket. . . . .	4
7	5744919	••KIT, decorative lug nut . . . . .	1
8	S.I.K.	•••CAP, stainless steel . . . . .	8
9	S.I.K.	•••PLASTIC INSERT, threaded . . . . .	8
10	S.I.K.	•••NUT AND LOCKWASHER ASSEMBLY, 1/4 - 20 x 1/2, keps. . . . .	8
11	S.I.K.	•••WASHER, flat, 1/4 . . . . .	8
12	5745100	•CAPS, center, stainless steel . . . . .	4
13	5745053	KIT, stainless steel hub cap with or without CTIS. . . . . SEE NOTE 2 . . . . .	1
14	5745054	•WHEEL COVER, stainless steel. . . . .	4
15	5744920	•KIT, wheel cover mounting bracket. . . . .	1
16	S.I.K.	••BRACKET, wheel cover hub . . . . .	2
17	S.I.K.	••LOCKWASHER, 7/16. . . . .	4
18	S.I.K.	••BOLT, 7/16 - 14 x 3/4, wheel cover bracket. . . . .	4
19	5745055	••KIT, decorative lug nut . . . . .	1
20	S.I.K.	•••CAP, stainless steel . . . . .	8
21	S.I.K.	•••PLASTIC INSERT, threaded . . . . .	8
22	S.I.K.	•••NUT AND LOCKWASHER ASSEMBLY, 1/4 - 20 x 1/2, keps . . . . .	8
23	S.I.K.	•••WASHER, flat, 1/4 . . . . .	8
24	5745100	•CAPS, center, stainless steel . . . . .	4
		NOTE 1: INCLUDES FOUR EACH OF KITS 05744919 AND 5744920.	
		NOTE 2: INCLUDES FOUR EACH OF KITS 05745055 AND 5744920.	

# 2001 HUMMER PARTS CATALOG

## 13-84 ACCESSORIES

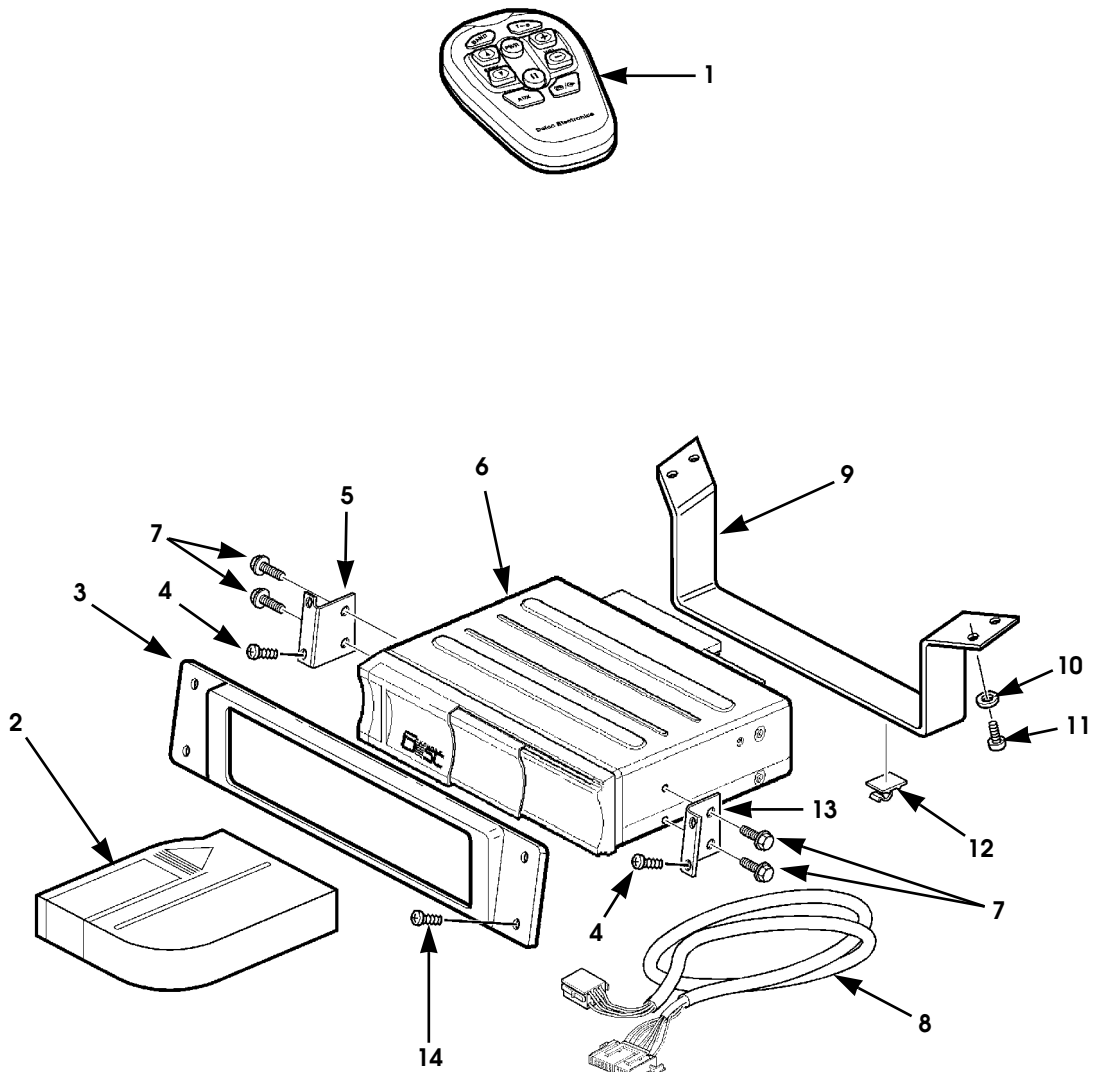

00-P13-003

Figure 13-41. CD Changer and Remote Control.

# 2001 HUMMER PARTS CATALOG

## ACCESSORIES 13-85

ITEM	PART NUMBER	DESCRIPTION	QTY
		<b>Figure 13-41.</b> <b>CD Changer and Remote Control.</b>	
1	5744737	REMOTE CONTROL . . . . .	1
2	5745149	MAGAZINE, 6-CD . . . . .	1
3	6010784	BEZEL, CD changer, SEE NOTE 1 . . . . .	1
4	9425422P2	SCREW, tapping, SEE NOTE 1 . . . . .	4
5	6010787	BRACKET, CD changer, L.H., SEE NOTE 1 . . . . .	1
6	6010797	CD CHANGER ASSEMBLY, 6-CD, SEE NOTE 1 . . . . .	1
7	S.I.A.	•SCREW, M5-.80 x 6 . . . . .	4
8	6011001	•CABLE, CD changer, SEE NOTE 1 . . . . .	1
9	6010786	BRACKET, CD changer, front, SEE NOTE 1 . . . . .	1
10	N/S	LOCKWASHER, #10, bracket, CD changer, SEE NOTE 1 . . . . .	4
11	N/S	SCREW, phcr, #10 - 32 x 3/4, SEE NOTE 1 . . . . .	4
12	6001543	CLIP, CD changer cable . . . . .	2
13	6010788	BRACKET, CD changer, R.H., SEE NOTE 1 . . . . .	1
14	N/S	SCREW, phcr, #10 - 32 x 7/8, SEE NOTE 2 . . . . .	4
	6001894	J-NUT (not illustrated), SEE NOTE 1 . . . . .	4
		NOTE 1: PART OF THE DELCO SIX-DISC CD CHANGER KIT, P/N 5745336.	
		NOTE 2: REUSE THE FASTENERS USED ON THE CD CHANGER HOLE COVER	



# 2001 HUMMER PARTS CATALOG

## 13-86 ACCESSORIES

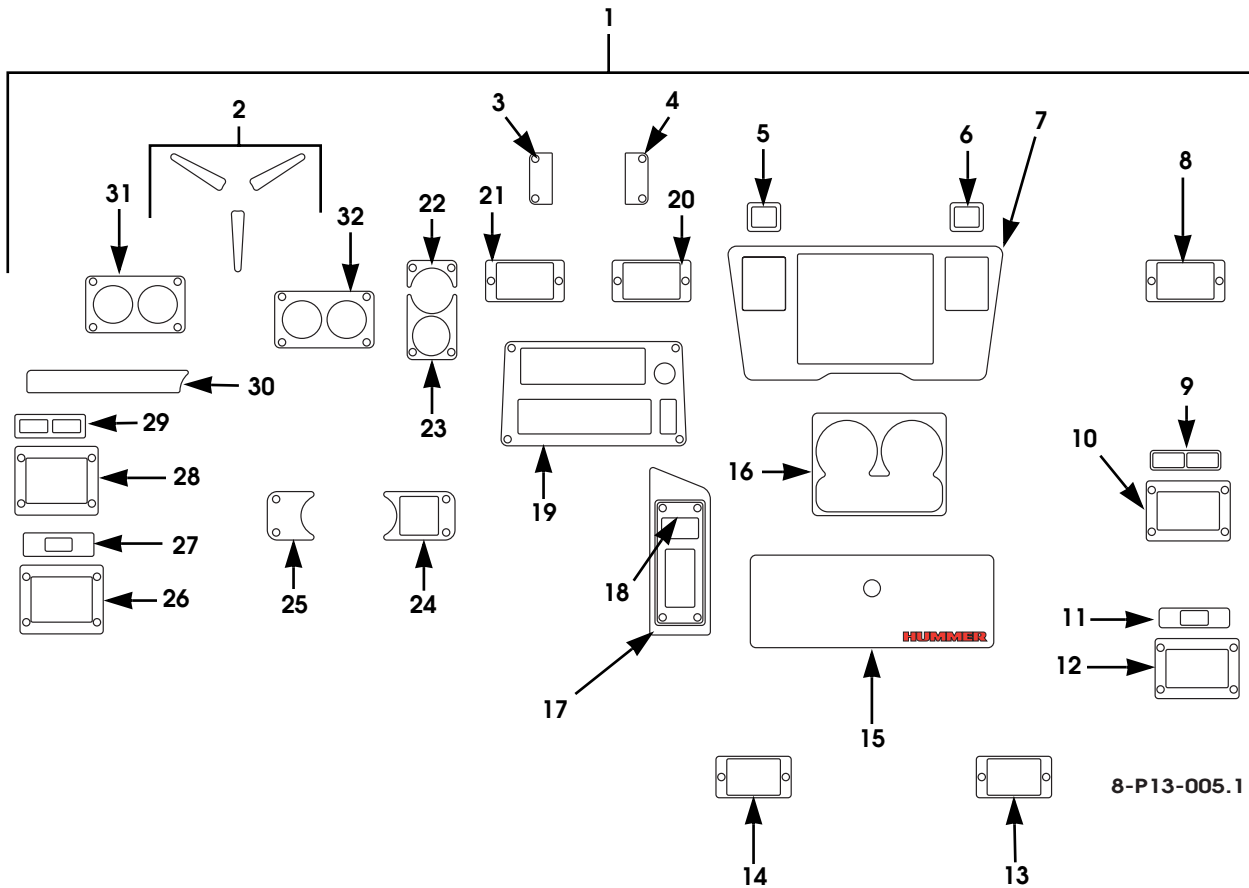

8-P13-005.1

Figure 13-42. Dash Trim Appliqué Kit, 1993 - 2000

# 2001 HUMMER PARTS CATALOG

## ACCESSORIES 13-87

ITEM	PART NUMBER	DESCRIPTION	QTY
		<b>Figure 13-42.</b> <b>Dash Trim Appliqué Kit, 1993 - 2000 (SEE NOTE 1)</b>	
1	5744905	KIT, Rosewood dash trim appliqué panels . . . . .	1
1	5744906	KIT, Carbon Fiber dash trim appliqué panels . . . . .	1
1	5744907	KIT, Carpathian Elm Burl dash trim appliqué panels . . . . .	1
2	S.I.K.	•PANEL, steering wheel accent . . . . .	3
3	S.I.K.	•PANEL, left CD accent . . . . .	1
4	S.I.K.	•PANEL, right CD accent . . . . .	1
5	S.I.K.	•PANEL, left cigar lighter . . . . .	1
6	S.I.K.	•PANEL, right cigar lighter . . . . .	1
7	S.I.K.	•PANEL, center console . . . . .	1
8	S.I.K.	•PANEL, passenger side vent . . . . .	1
9	S.I.K.	•PANEL, passenger door switch . . . . .	1
10	S.I.K.	•PANEL, passenger door handle . . . . .	1
11	S.I.K.	•PANEL, left rear door switch . . . . .	1
12	S.I.K.	•PANEL, left rear door handle . . . . .	1
13	S.I.K.	•PANEL, right rear vent . . . . .	1
14	S.I.K.	•PANEL, left rear vent . . . . .	1
15	S.I.K.	•PANEL, glove box cover . . . . .	1
16	S.I.K.	•PANEL, cup holder trim . . . . .	1
17	S.I.K.	•PANEL, window control surround . . . . .	1
18	S.I.K.	•PANEL, power window control . . . . .	1
19	S.I.K.	•PANEL, radio/climate control . . . . .	1
20	S.I.K.	•PANEL, right center vent . . . . .	1
21	S.I.K.	•PANEL, left center vent . . . . .	1
22	S.I.K.	•PANEL, upper RPM gauge/clock . . . . .	1
23	S.I.K.	•PANEL, lower RPM gauge/clock . . . . .	1
24	S.I.K.	•PANEL, right tire pressure control . . . . .	1
25	S.I.K.	•PANEL, left tire pressure control . . . . .	1
26	S.I.K.	•PANEL, right rear door handle . . . . .	1
27	S.I.K.	•PANEL, right rear door switch . . . . .	1
28	S.I.K.	•PANEL, driver door handle . . . . .	1
29	S.I.K.	•PANEL, driver door switch . . . . .	1
30	S.I.K.	•PANEL, light switch . . . . .	1
31	S.I.K.	•PANEL, left gauge cluster . . . . .	1
32	S.I.K.	•PANEL, right gauge cluster . . . . .	1
		NOTE 1: DASH TRIM APPLIQUÉ KIT FOR MODEL YEAR 2001 VEHICLES HAS NOT YET BEEN RELEASED.	

# 2001 HUMMER PARTS CATALOG

## 13-88 ACCESSORIES



8-S13-003

Figure 13-43. Electric Seat Heater Kit.

# 2001 HUMMER PARTS CATALOG

## ACCESSORIES 13-89

ITEM	PART NUMBER	DESCRIPTION	QTY
		<b>Figure 13-43. Electric Seat Heater Kit.</b>	
1	5744890	KIT, electric seat heater .....	1
2	5744927	•ELEMENT, heating, cushion .....	1
3	S.I.K.	•HOG RING .....	A/R
4	5744926	•ELEMENT, heating, back .....	1
	5744924	•SWITCH, seat heater (not illustrated) .....	1
	5744925	•MODULE, seat heater (not illustrated) .....	

# 2001 HUMMER PARTS CATALOG

## 13-90 ACCESSORIES

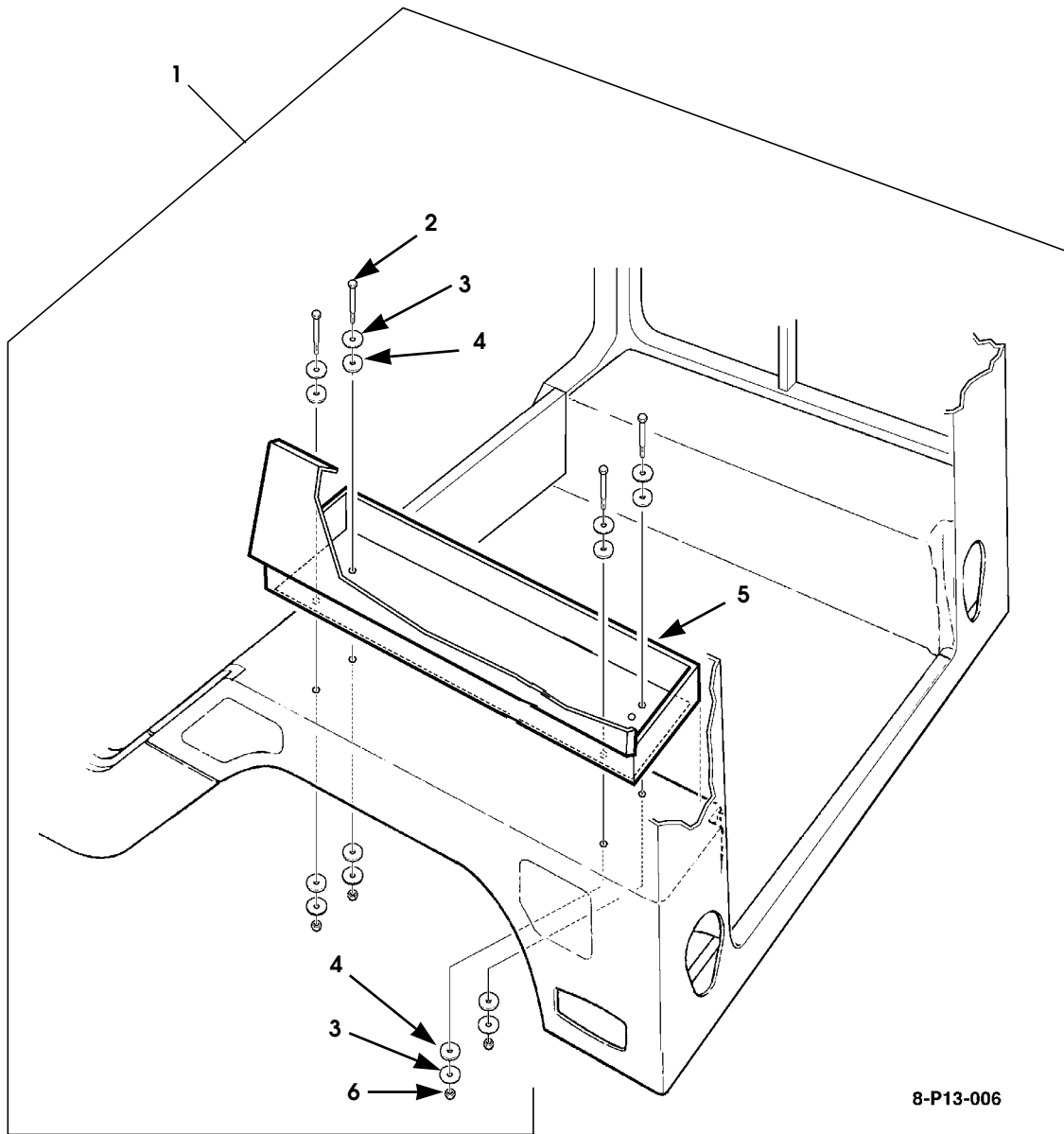

Figure 13-44. Off-Road Accessory Kit, Station Wagon, Model 84.

# 2001 HUMMER PARTS CATALOG

## ACCESSORIES 13-91

ITEM	PART NUMBER	DESCRIPTION	QTY
		<b>Figure 13-44.</b> <b>Off-Road Accessory Kit, Station Wagon, Model 84.</b>	
1	5744704	KIT, off-road accessory . . . . .	1
2	MS90728-13	•BOLT . . . . .	4
3	5935291B9	•PLATE, retainer . . . . .	8
4	6001595	•GASKET, foam washer . . . . .	8
5	5744801	•TOOL BOX, off-road, large . . . . .	1
6	MS51943-31	•LOCKNUT, 1/4 - 20, CAD . . . . .	4
	5744881	•STRAP, vehicle recovery (not illustrated here; see page 13-8) . . . . .	1
	6004898	•KIT, pioneer tool (not illustrated here; see page 13-22)	1
	5744718	•OFF ROAD PARTS PACKAGE (not illustrated) . . . . .	1
	S.I.K.	••TESTER, 12-volt circuit. . . . .	1
	S.I.K.	••GAUGE, tire pressure . . . . .	1
	S.I.K.	••CABLE SET, jumper . . . . .	1
	S.I.K.	••FIRST AID AND BURN KIT . . . . .	1
	S.I.K.	••FLASHLIGHT, Mag-Life . . . . .	1
	S.I.K.	••FIRE EXTINGUISHER, 2.5-lb . . . . .	1
	S.I.K.	••PLIERS, 6 1/2" Channel-Lock. . . . .	1
	S.I.K.	••FUSE ASSORTMENT. . . . .	1
	S.I.K.	••PLIERS, lineman's type . . . . .	1

# 2001 HUMMER PARTS CATALOG

## 13-92 ACCESSORIES

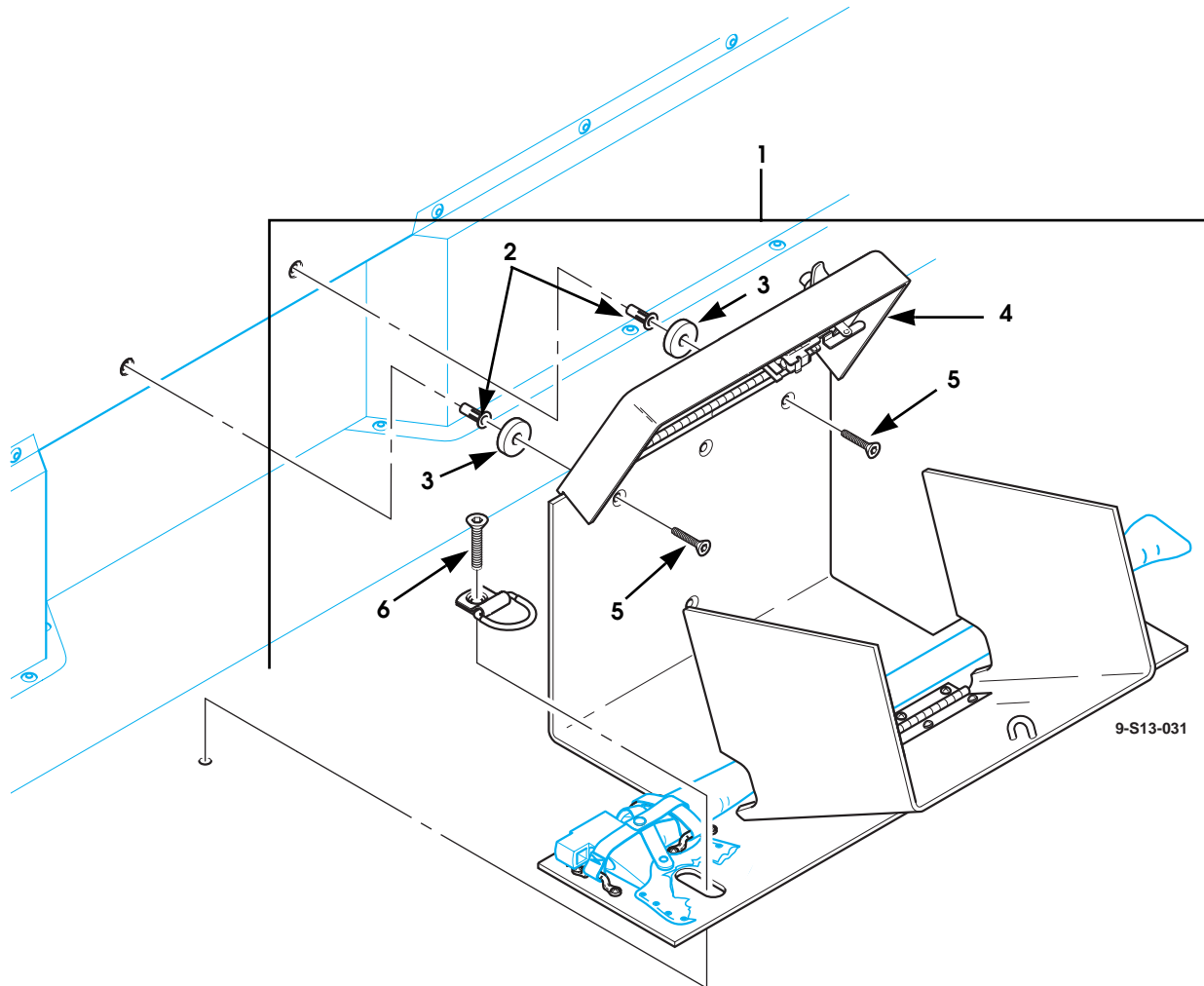

Figure 13-45. Off-Road Accessory Kit, 4-Door Hard Top and 4-Door Soft Top, Models 83 and 90.

# 2001 HUMMER PARTS CATALOG

## ACCESSORIES 13-93

ITEM	PART NUMBER	DESCRIPTION	QTY
		<b>Figure 13-45. Off-Road Accessory Kit, 4-Door Hard Top and 4-Door Soft Top, Models 83 and 90.</b>	
1	5744705	KIT, off-road accessory . . . . .	1
		83, 89, 90	
2	5935428	•NUT INSERT . . . . .	2
3	6000942B2	•SPACER . . . . .	2
4	5744738	•TOOL BOX, off road . . . . .	1
5	S.I.K.	•SCREW, flathead, 3/8-16 x 1 3/4 . . . . .	2
6	S.I.K.	•SCREW, flathead, 1/2-13 X 2 1/4 . . . . .	2
	5744881	•STRAP, vehicle recovery (not illustrated here; see page 13-8) . . . . .	1
	6004898	•KIT, pioneer tool (not illustrated here; see page 13-22)	1
	5744718	•OFF ROAD PARTS PACKAGE (not illustrated) . . . . .	1
	S.I.K.	••TESTER, 12-volt circuit. . . . .	1
	S.I.K.	••GAUGE, tire pressure. . . . .	1
	S.I.K.	••CABLE SET, jumper. . . . .	1
	S.I.K.	••FIRST AID AND BURN KIT . . . . .	1
	S.I.K.	••FLASHLIGHT, Mag-Lite . . . . .	1
	S.I.K.	••FIRE EXTINGUISHER, 2.5-lb . . . . .	1
	S.I.K.	••PLIERS, 6 1/2" Channel-Lock. . . . .	1
	S.I.K.	••FUSE ASSORTMENT. . . . .	1
	S.I.K.	••PLIERS, lineman's type . . . . .	1



# 2001 HUMMER PARTS CATALOG

## 13-94 ACCESSORIES

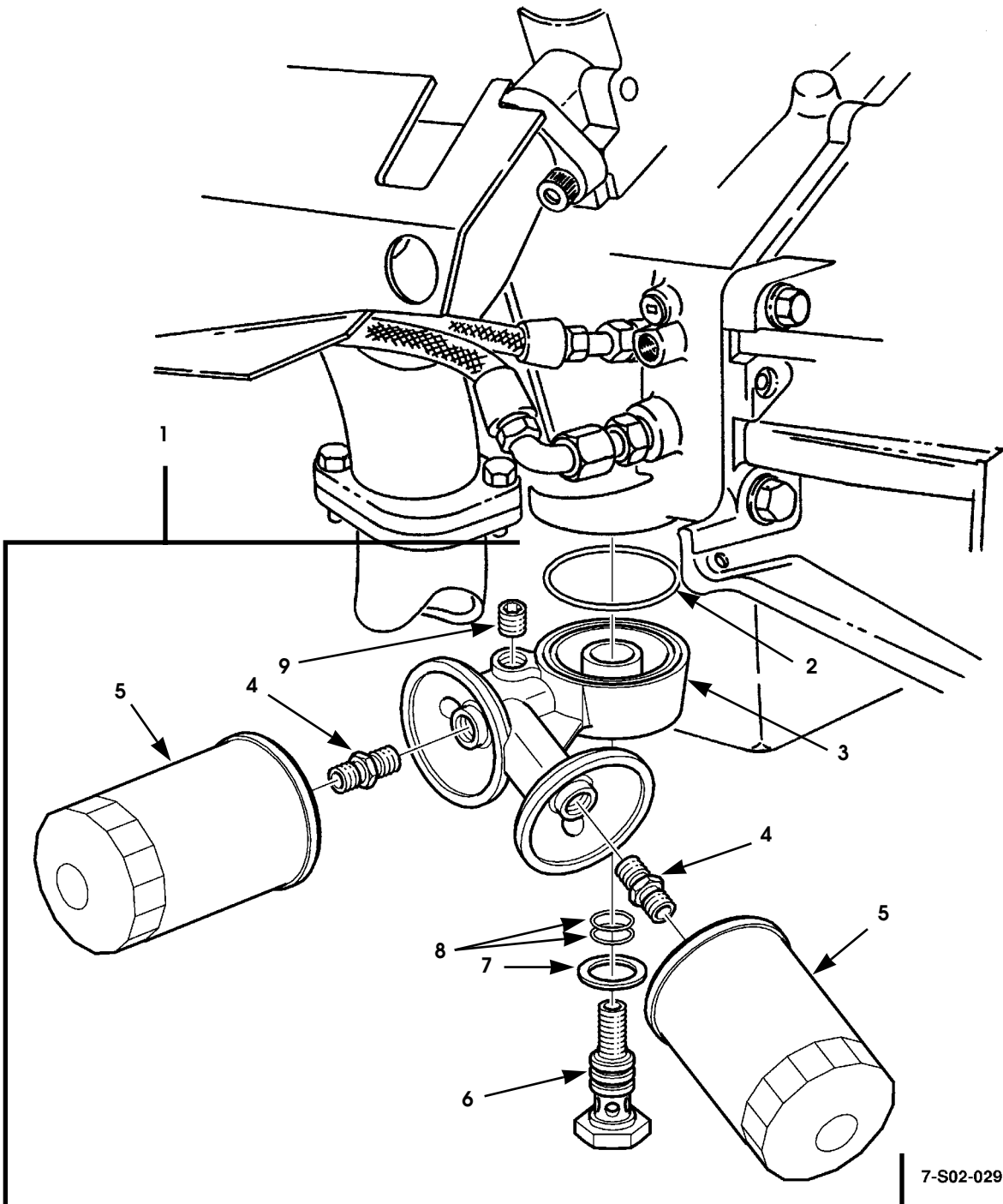

Figure 13-46. Dual Oil Filter Kit

# 2001 HUMMER PARTS CATALOG

## ACCESSORIES 13-95

ITEM	PART NUMBER	DESCRIPTION	QTY
		<b>Figure 13-46. Dual Oil Filter Kit</b>	
1	5744867	DUAL OIL FILTER KIT .....	1
2	MS28775-236	•O-RING .....	1
3	5594912	•ADAPTER, dual oil filter .....	1
4	12339405	•CONNECTOR, oil filter, SEE NOTE 1 .....	1
5	5715388	•FILTER, engine oil .....	2
6	12339410	•BOLT, oil filter. ....	1
7	12339409	•GASKET, oil filter bolt .....	1
8	MS28775-020	•O-RING .....	2
9	444698	•PIPE PLUG, 3/8 - 18. ....	1
		NOTE 1: ONLY ONE OIL FILTER CONNECTOR IS INCLUDED IN KIT. REUSE CONNECTOR ALREADY ON VEHICLE.	

# 2001 HUMMER PARTS CATALOG

## 13-96 ACCESSORIES

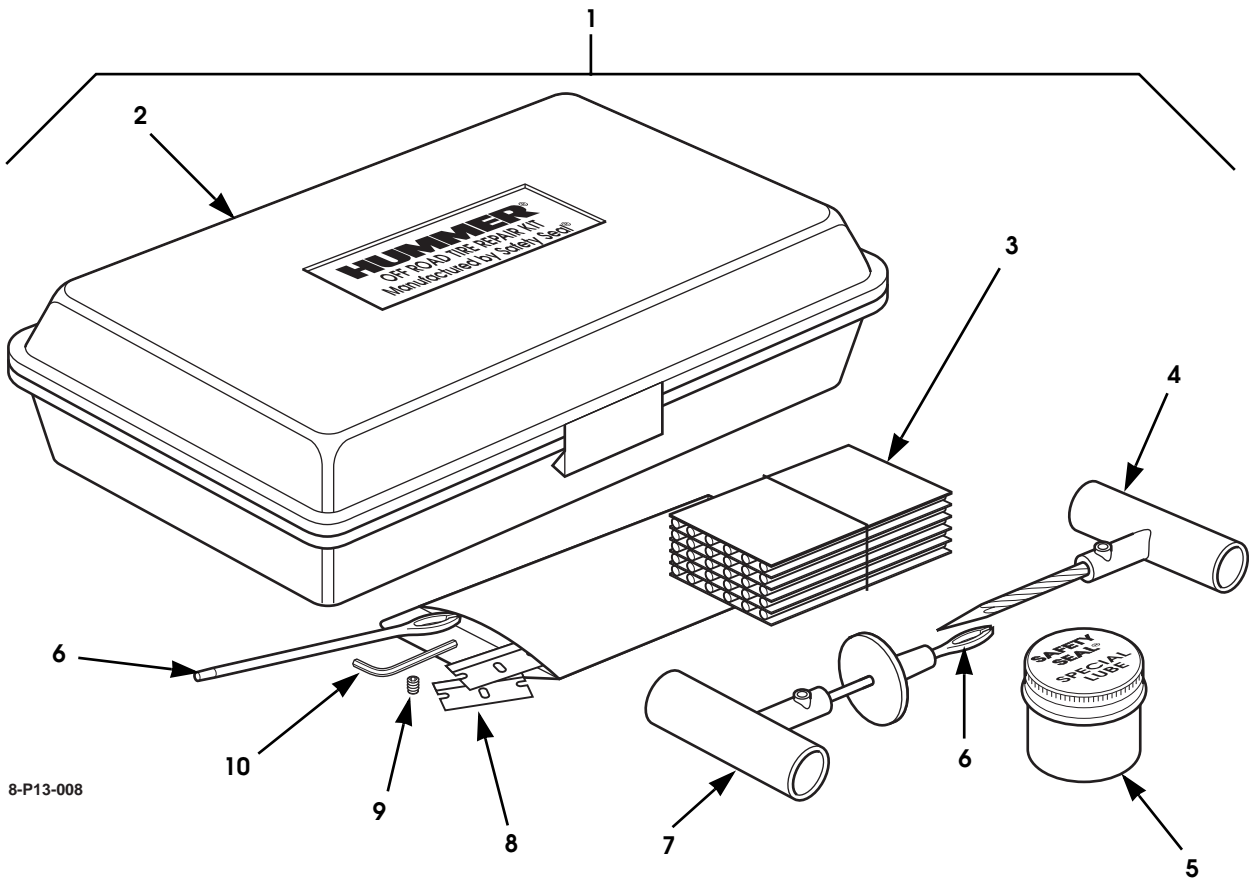

Figure 13-47. Tire Repair Accessory Kit, External.

# 2001 HUMMER PARTS CATALOG

## ACCESSORIES 13-97

ITEM	PART NUMBER	DESCRIPTION	QTY
		<b>Figure 13-47.</b> <b>Tire Repair Accessory Kit, External.</b>	
1	5745015	KIT, external tire repair accessory . . . . .	1
2	S.I.K.	•TOOLBOX . . . . .	1
3	S.I.K.	•SAFETY SEAL, 1/4" dia x 4" long self-vulcanizing fiber bar	30
4	S.I.K.	•REAMER, T-handle . . . . .	1
5	S.I.K.	•SPECIAL LUBE, 4-oz plastic jar . . . . .	1
6	S.I.K.	•NEEDLE, insertion, 0.18 dia . . . . .	2
7	S.I.K.	•SAFETY SEAL INSERTION TOOL, T-handle . . . . .	1
8	S.I.K.	•CUTTING BLADE . . . . .	2
9	S.I.K.	•SET SCREW, 1/4 hex socket head . . . . .	2
10	S.I.K.	•HEX KEY WRENCH, 1/4" . . . . .	1
11	S.I.K.	•INSTRUCTION BOOKLET (not illustrated) . . . . .	1

# 2001 HUMMER PARTS CATALOG

## 13-98 ACCESSORIES

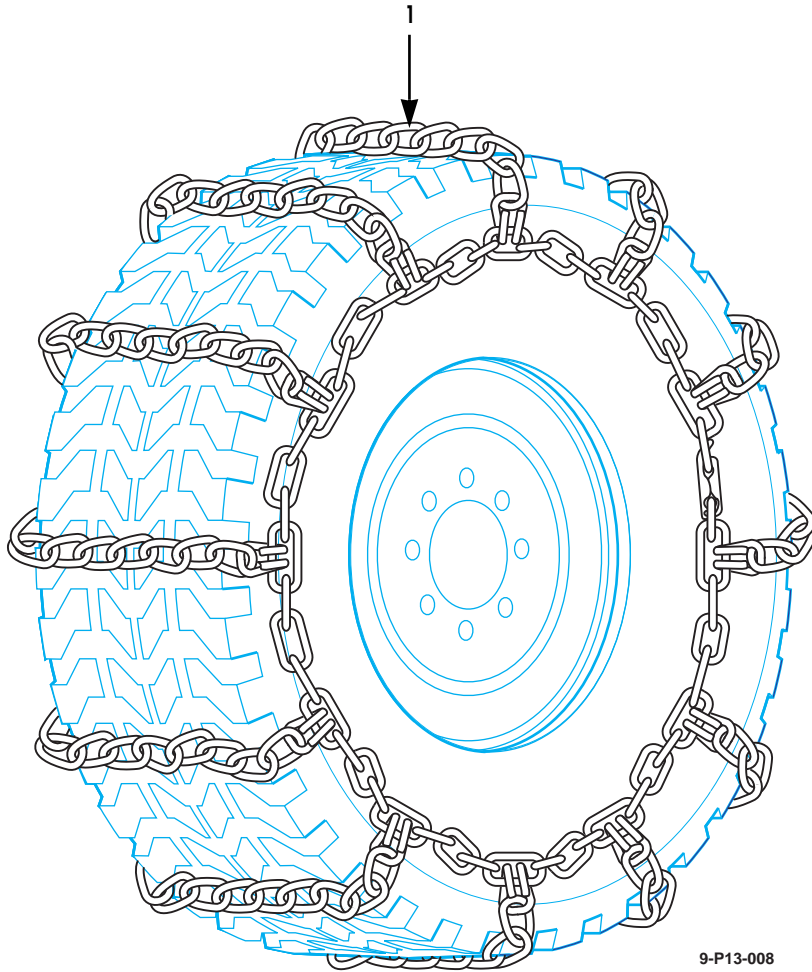

*Figure 13-48. Tire Chains*

# 2001 HUMMER PARTS CATALOG

ACCESSORIES 13-99

ITEM	PART NUMBER	DESCRIPTION	QTY
1	5569255	Figure 13-48. Tire Chains  TIRE CHAINS, one pair, for one axle . . . . .	2

# 2001 HUMMER PARTS CATALOG

## 13-100 ACCESSORIES

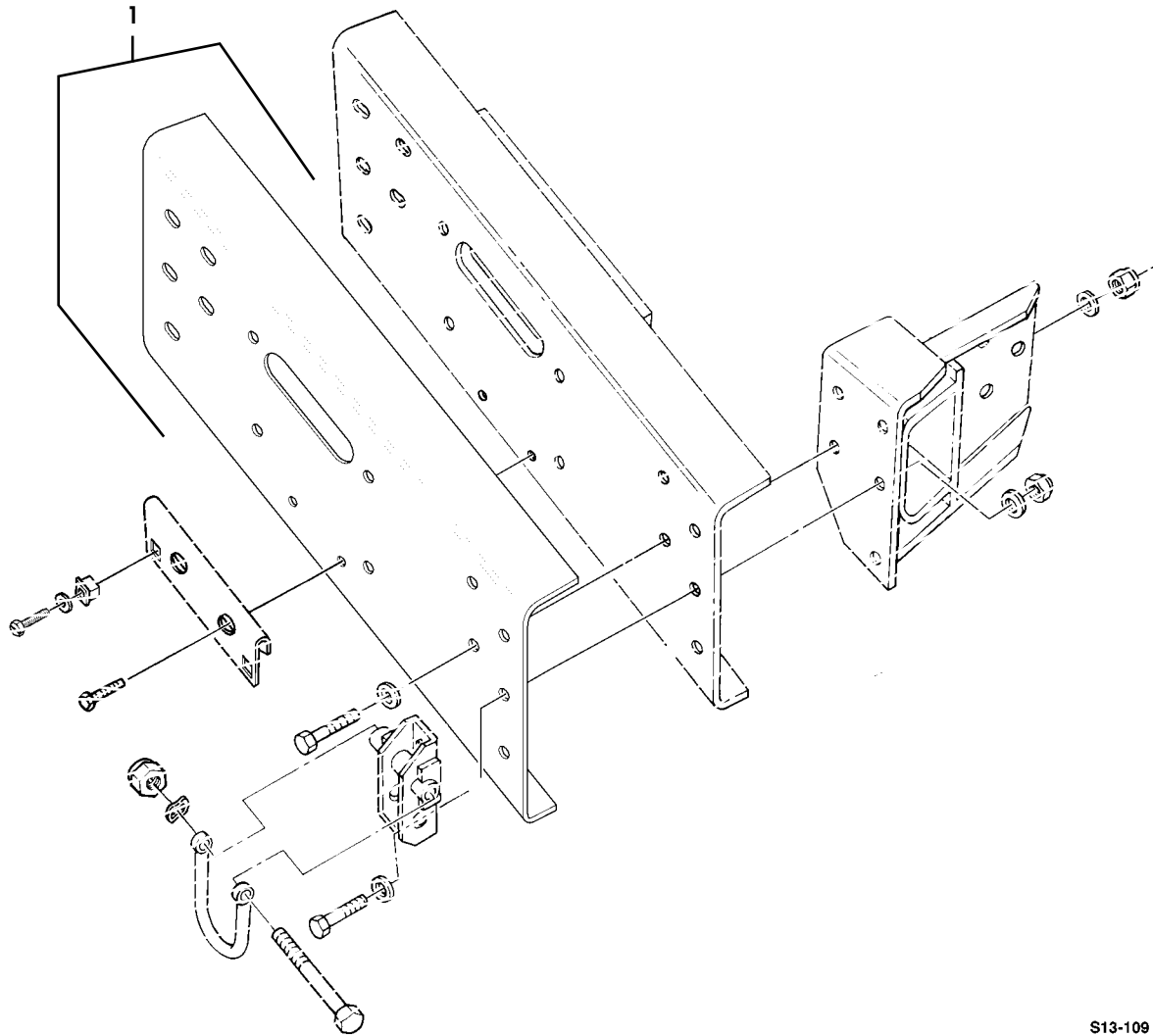

S13-109

*Figure 13-49. Bumper (Front with Winch) Cover Kit, Polished or Brushed Stainless Steel.*

# 2001 HUMMER PARTS CATALOG

## ACCESSORIES 13-101

ITEM	PART NUMBER	DESCRIPTION	QTY
1	5745070	<b>Figure 13-49. Bumper (Front with Winch) Cover Kit, Polished or Brushed Stainless Steel.</b>	1
1	5745189	COVER, front bumper with winch, polished stainless steel	1
		COVER, front bumper with winch, brushed stainless steel	1



# 2001 HUMMER PARTS CATALOG

## 13-102 ACCESSORIES

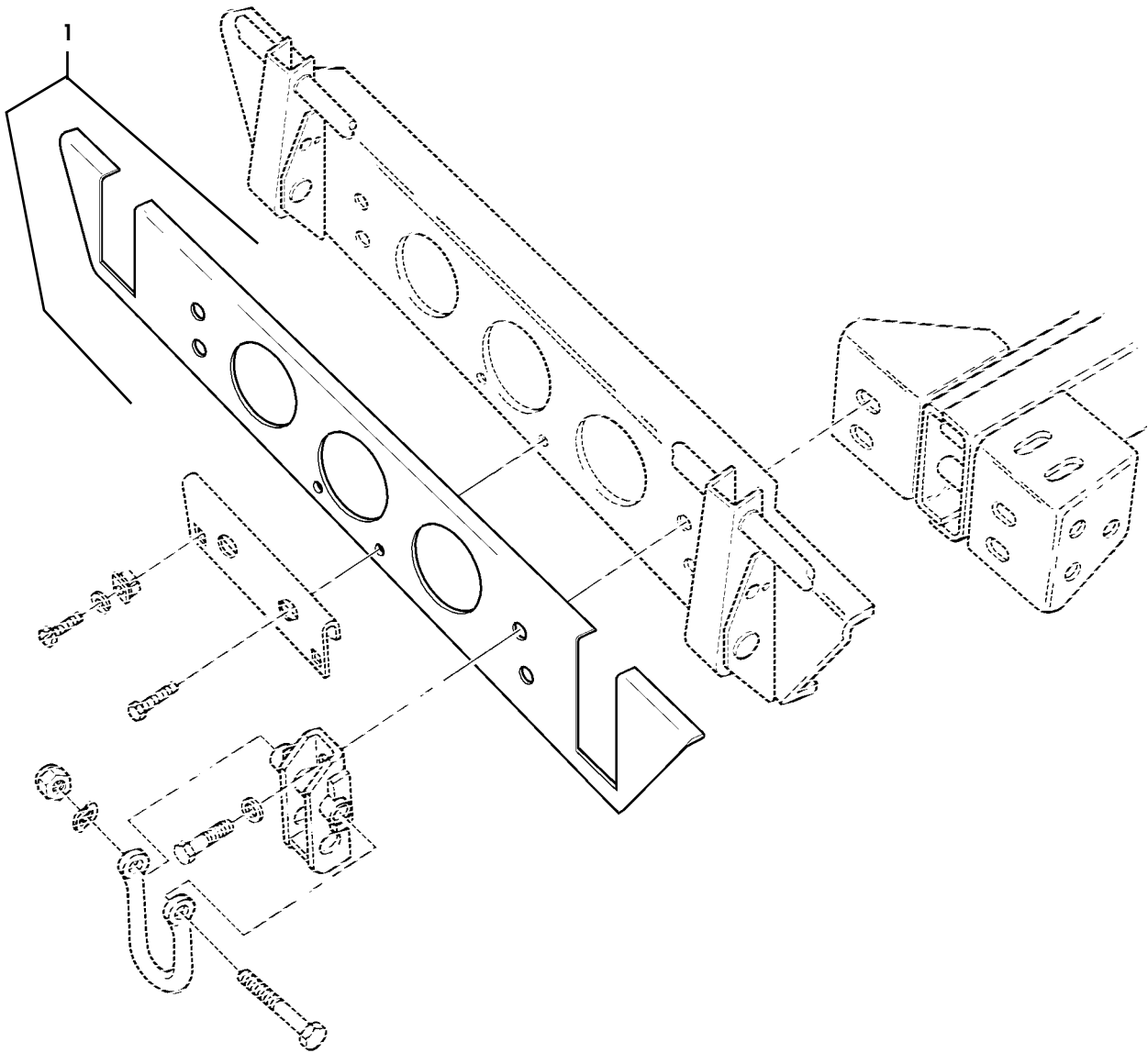

9-P13-013

*Figure 13-50. Bumper (Front with Brushguard and without Winch) Cover Kit, Polished or Brushed Stainless Steel.*

# 2001 HUMMER PARTS CATALOG

## ACCESSORIES 13-103

ITEM	PART NUMBER	DESCRIPTION	QTY
		<b>Figure 13-50. Bumper (Front with Brushguard and without Winch) Cover Kit, Polished or Brushed Stainless Steel.</b>	
1	5745079	COVER, front bumper with brushguard and without winch, polished stainless steel . . . . .	1
1	5745192	COVER, front bumper with brushguard and without winch, brushed stainless steel . . . . .	1

# 2001 HUMMER PARTS CATALOG

## 13-104 ACCESSORIES

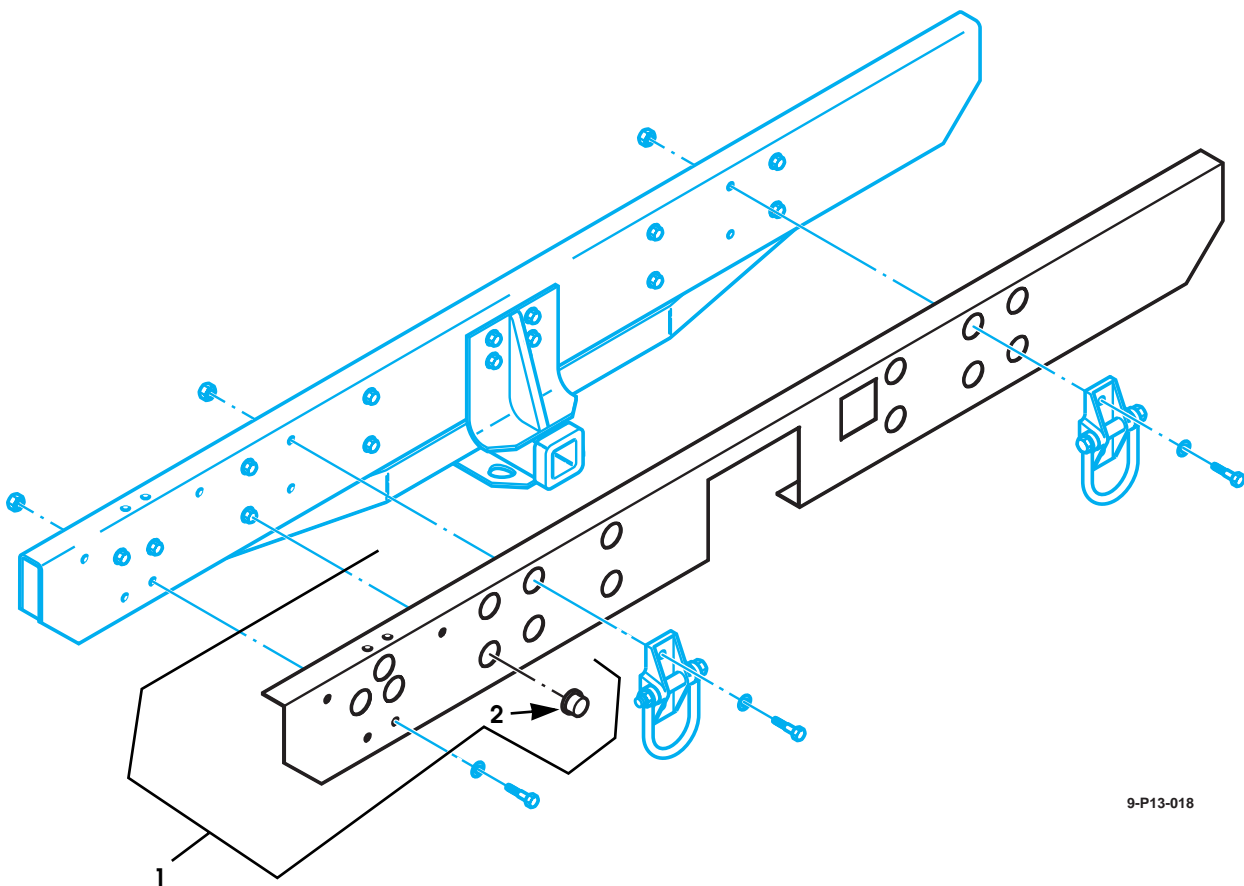

9-P13-018

*Figure 13-51. Bumper (Rear) Cover, Polished or Brushed Stainless Steel.*

# 2001 HUMMER PARTS CATALOG

## ACCESSORIES 13-105

ITEM	PART NUMBER	DESCRIPTION	QTY
		<b>Figure 13-51. Bumper (Rear) Cover, Polished or Brushed Stainless Steel.</b>	
1	5745115	COVER, rear bumper, polished stainless steel . . . . .	1
1	5745207	COVER, rear bumper, brushed stainless steel. . . . .	1
2	5745148	•COVER, bolt . . . . .	8

# 2001 HUMMER PARTS CATALOG

## 13-106 ACCESSORIES

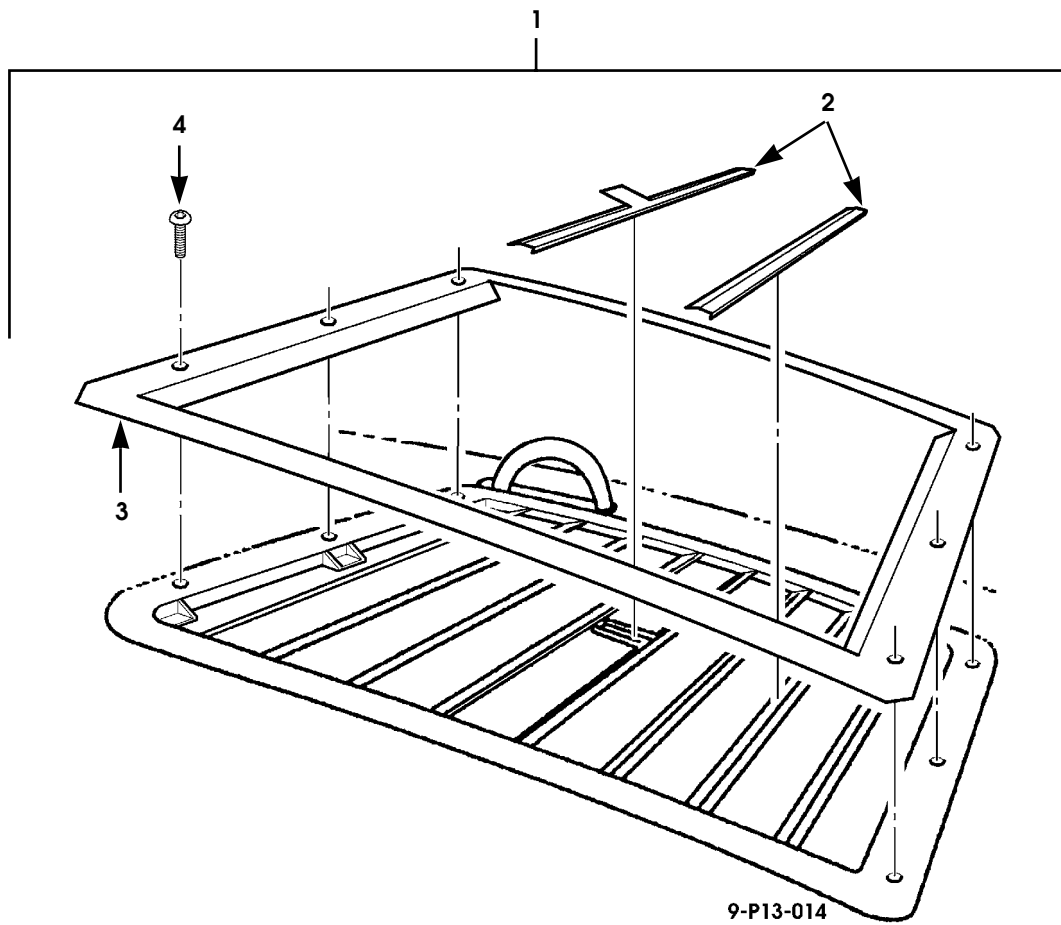

Figure 13-52. Grille (Upper) Cover, Polished or Brushed Stainless Steel.

# 2001 HUMMER PARTS CATALOG

## ACCESSORIES 13-107

ITEM	PART NUMBER	DESCRIPTION	QTY
		<b>Figure 13-52. Grille (Upper) Cover, Polished or Brushed Stainless Steel.</b>	
1	5745020	COVER, grille, polished stainless steel. . . . .	1
2	S.I.K.	•GRILLE SLAT, polished stainless steel . . . . .	8
3	S.I.K.	•GRILLE FRAME, polished stainless steel . . . . .	1
4	S.I.K.	•SCREW, stainless steel . . . . .	6
1	5745183	COVER, grille, brushed stainless steel. . . . .	1
2	S.I.K.	•GRILLE SLAT, brushed stainless steel. . . . .	8
3	S.I.K.	•GRILLE FRAME, brushed stainless steel . . . . .	1
4	S.I.K.	•SCREW, stainless steel . . . . .	6

# 2001 HUMMER PARTS CATALOG

## 13-108 ACCESSORIES

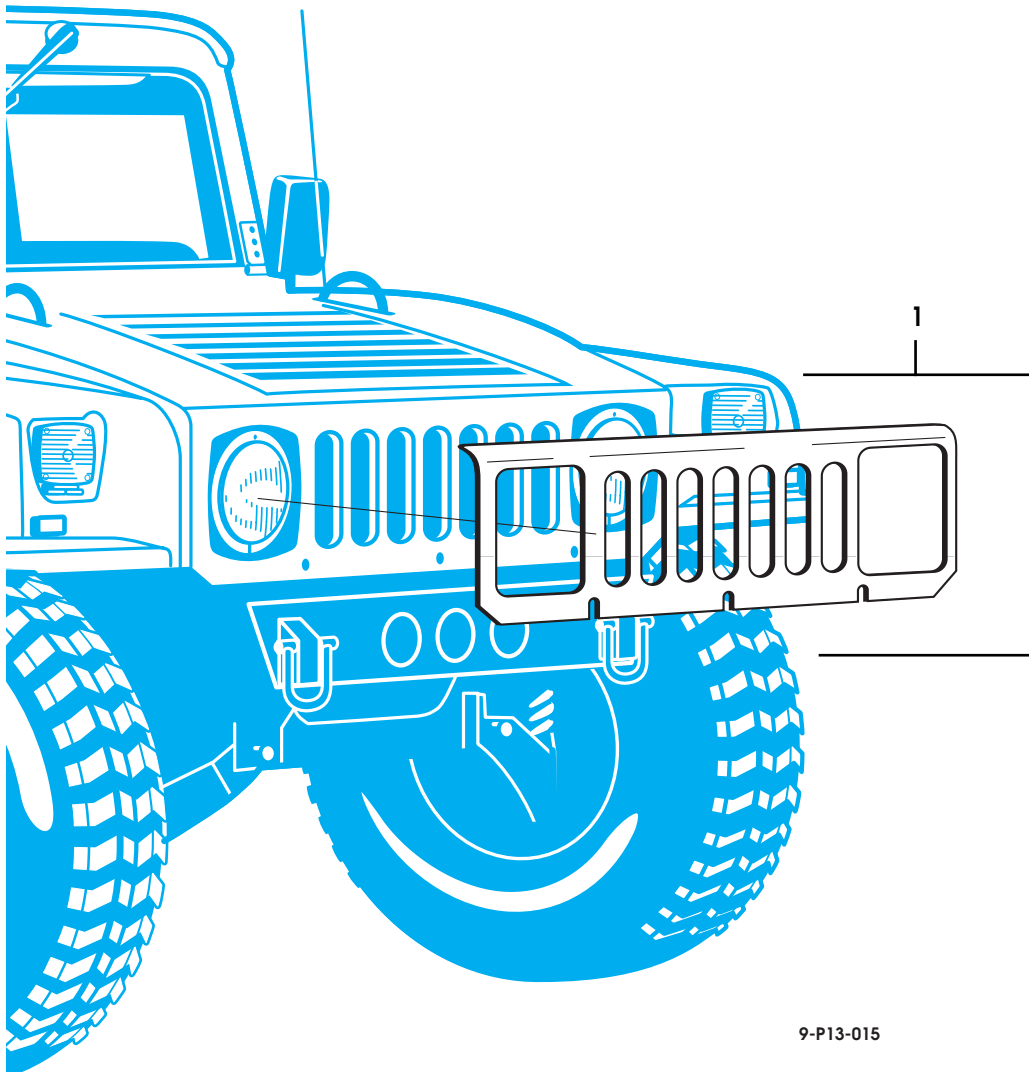

9-P13-015

*Figure 13-53. Grille (Front) Cover, Polished or Brushed Stainless Steel.*

# 2001 HUMMER PARTS CATALOG

## ACCESSORIES 13-109

ITEM	PART NUMBER	DESCRIPTION	QTY
		<b>Figure 13-53.</b> <b>Grille (Front) Cover, Polished or Brushed Stainless Steel.</b>	
1	5745069	COVER, front grille, polished stainless steel . . . . .	1
1	5745186	COVER, front grille, brushed stainless steel . . . . .	1



# 2001 HUMMER PARTS CATALOG

## 13-110 ACCESSORIES

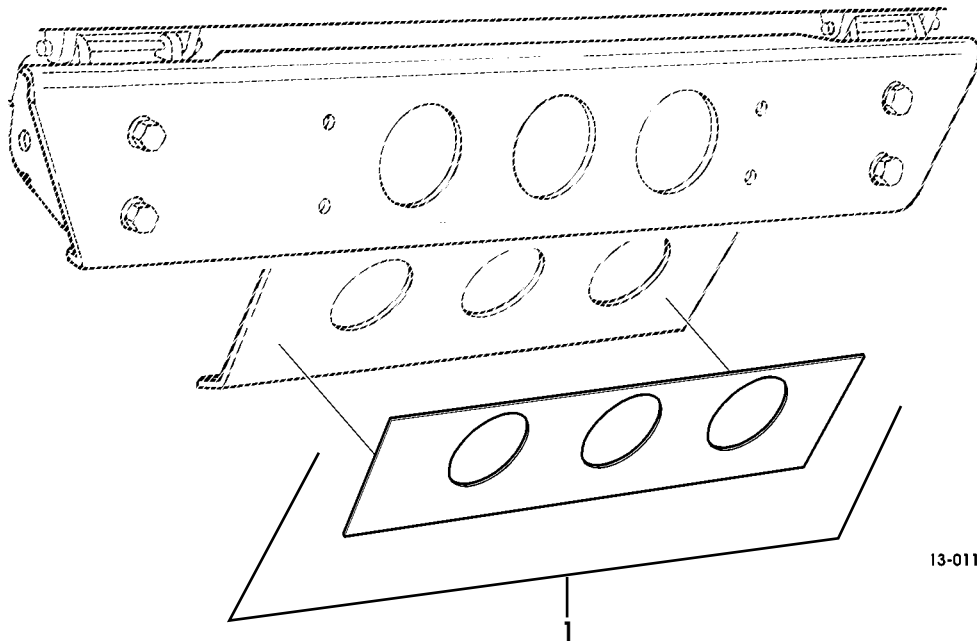

13-011.1

*Figure 13-54. Skid Plate Cover, Polished Stainless Steel.*

# 2001 HUMMER PARTS CATALOG

## ACCESSORIES 13-111

ITEM	PART NUMBER	DESCRIPTION	QTY
1	5745071	<p>Figure 13-54. Skid Plate Cover, Polished Stainless Steel.</p> <ul style="list-style-type: none"><li>•COVER, skid plate, polished stainless steel . . . . .</li></ul>	1

# 2001 HUMMER PARTS CATALOG

## 13-112 ACCESSORIES

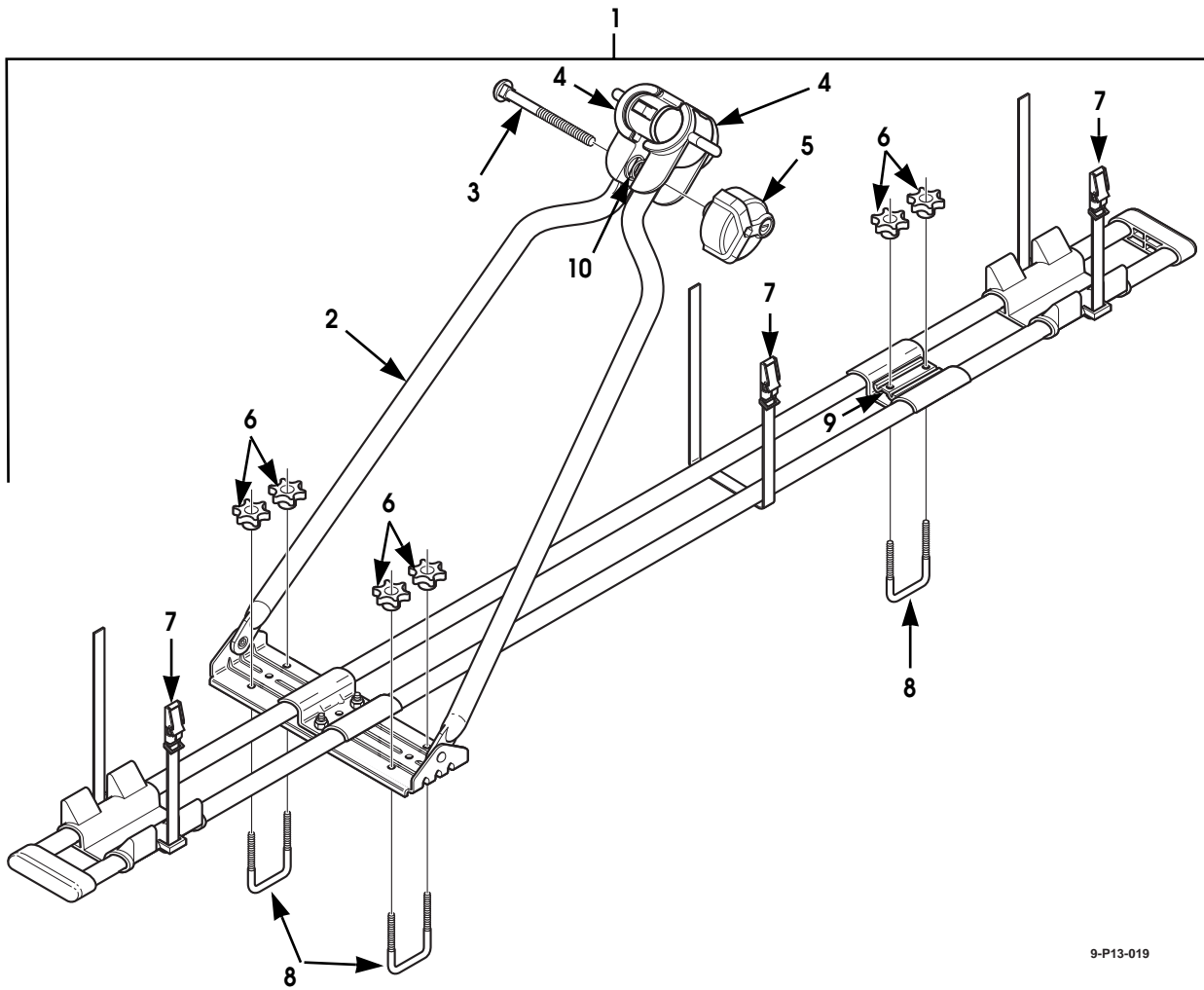

9-P13-019

Figure 13-55. Bike Rack Kit.

# 2001 HUMMER PARTS CATALOG

## ACCESSORIES 13-113

ITEM	PART NUMBER	DESCRIPTION	QTY
		<b>Figure 13-55. Bike Rack Kit.</b>	
1	5745067	KIT, bike rack . . . . .	1
2	5745065	•BIKE RACK . . . . .	1
3	S.I.K.	••BOLT, carriage . . . . .	1
4	S.I.K.	••TUBE CLAMP, half . . . . .	2
5	S.I.K.	••LOCKING WHEEL . . . . .	1
6	S.I.K.	••THUMB SCREW . . . . .	6
7	S.I.K.	••STRAP . . . . .	3
8	S.I.K.	••U-BOLT . . . . .	3
9	S.I.K.	••PLATE, spacer . . . . .	1
10	S.I.K.	••SPRING . . . . .	1

# 2001 HUMMER PARTS CATALOG

## 13-114 ACCESSORIES

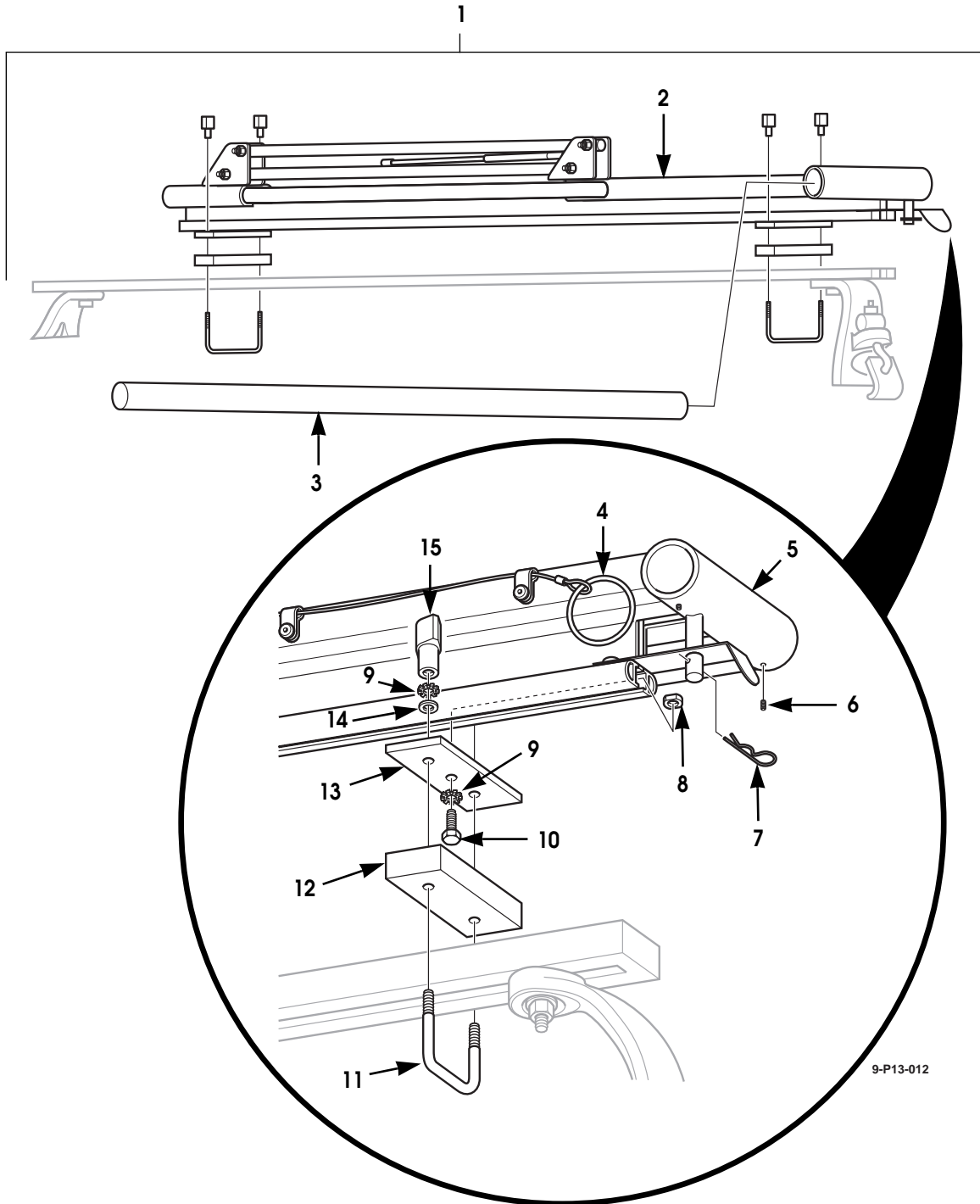

Figure 13-56. Roof Rack Kit, Side Load.

# 2001 HUMMER PARTS CATALOG

## ACCESSORIES 13-115

ITEM	PART NUMBER	DESCRIPTION	QTY
		<b>Figure 13-56. Roof Rack Kit, Side Load.</b>	
1	5745051	KIT, side load roof rack . . . . .	1
2	S.I.K.	•ROOF RACK, half . . . . .	2
3	S.I.K.	•BAR, handle . . . . .	1
4	S.I.K.	•RING, quick release. . . . .	1
5	S.I.K.	•HOLDER, handle bar . . . . .	2
6	S.I.K.	•SET SCREW . . . . .	2
7	S.I.K.	•PIN, hitch . . . . .	2
8	S.I.K.	•NUT . . . . .	4
9	S.I.K.	•WASHER, lock . . . . .	10
10	S.I.K.	•SCREW . . . . .	4
11	S.I.K.	•U-BOLT . . . . .	4
12	S.I.K.	•PAD, rubber . . . . .	4
13	S.I.K.	•MOUNTING FOOT . . . . .	4
14	S.I.K.	•WASHER, flat. . . . .	8
15	S.I.K.	•NUT, wing . . . . .	8

# 2001 HUMMER PARTS CATALOG

## 13-116 ACCESSORIES

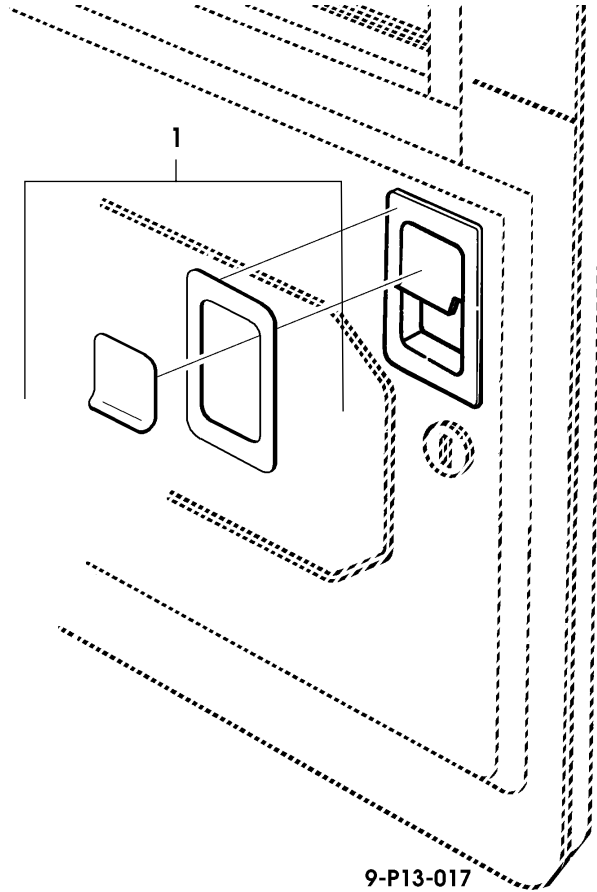

*Figure 13-57. Door Handle and Bezel Covers, Polished and Brushed Stainless Steel.*

# 2001 HUMMER PARTS CATALOG

## ACCESSORIES 13-117

ITEM	PART NUMBER	DESCRIPTION	YEAR
		<b>Figure 13-57. Door Handle and Bezel Covers, Polished and Brushed Stainless Steel.</b>	
1	5745102	COVERS, door handle and bezel (four-door), polished stainless steel . . . . . 83, 89, 90	4
1	5745101	COVERS, door handle and bezel (six-door), polished stainless steel . . . . . 84	4
1	5745201	COVERS, door handle and bezel (four-door), brushed stainless steel . . . . . 83, 89, 90	6
1	5745204	COVERS, door handle and bezel (six-door), brushed stainless steel . . . . . 84	6



# 2001 HUMMER PARTS CATALOG

## 13-118 ACCESSORIES

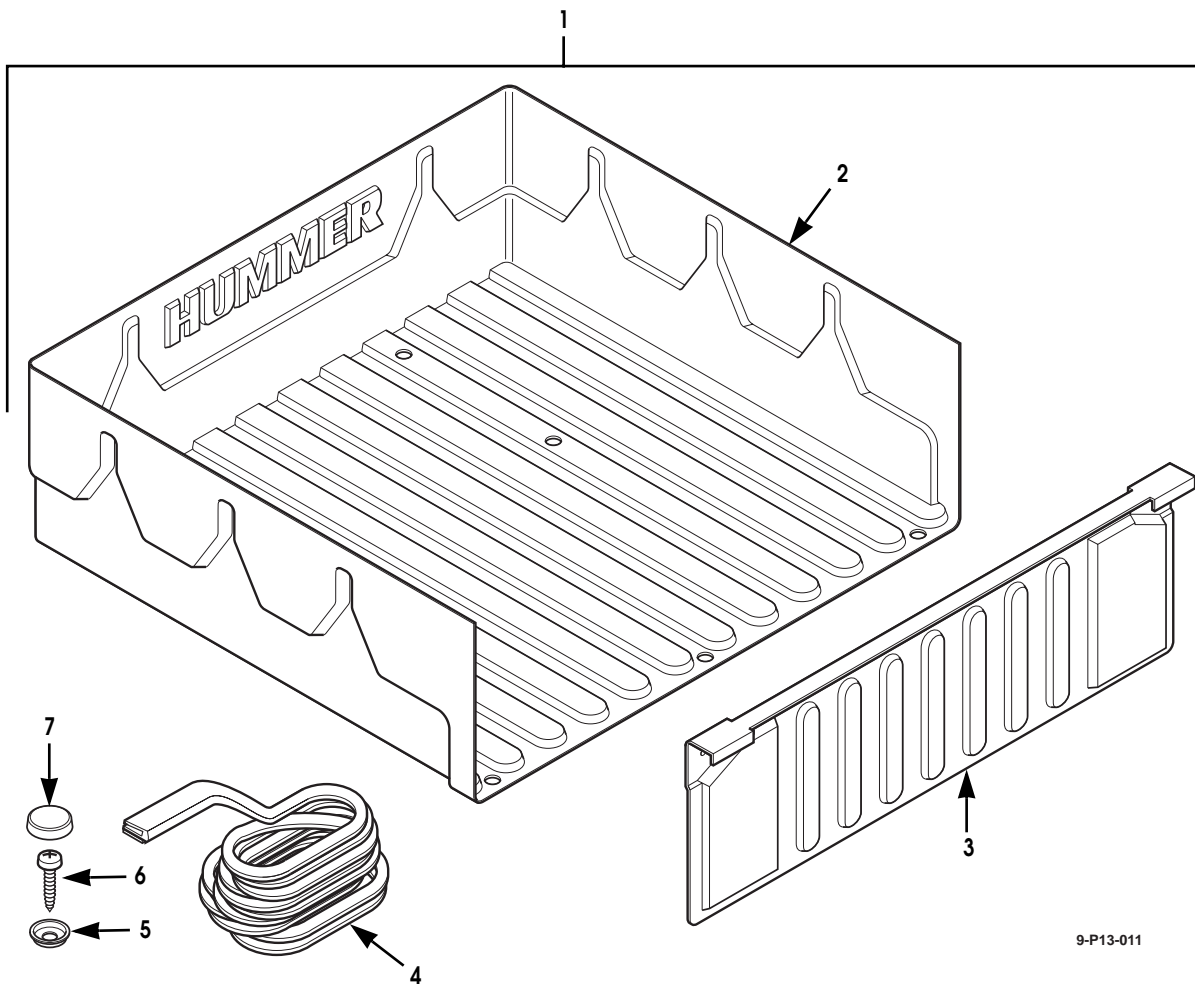

9-P13-011

Figure 13-58. Bedliner Kit.

# 2001 HUMMER PARTS CATALOG

## ACCESSORIES 13-119

ITEM	PART NUMBER	DESCRIPTION	QTY
		<b>Figure 13-58. Bedliner Kit.</b>	
1	5745029	KIT, bedliner .....	1
2	S.I.K.	•BEDLINER .....	1
3	S.I.K.	•COVER, tailgate. ....	1
4	S.I.K.	•EDGE TRIM STRIP .....	4
5	S.I.K.	•WASHER, cap lock. ....	2
6	S.I.K.	•SCREW .....	2
7	S.I.K.	•COVER, cap lock. ....	2

# 2001 HUMMER PARTS CATALOG

## 13-120 ACCESSORIES

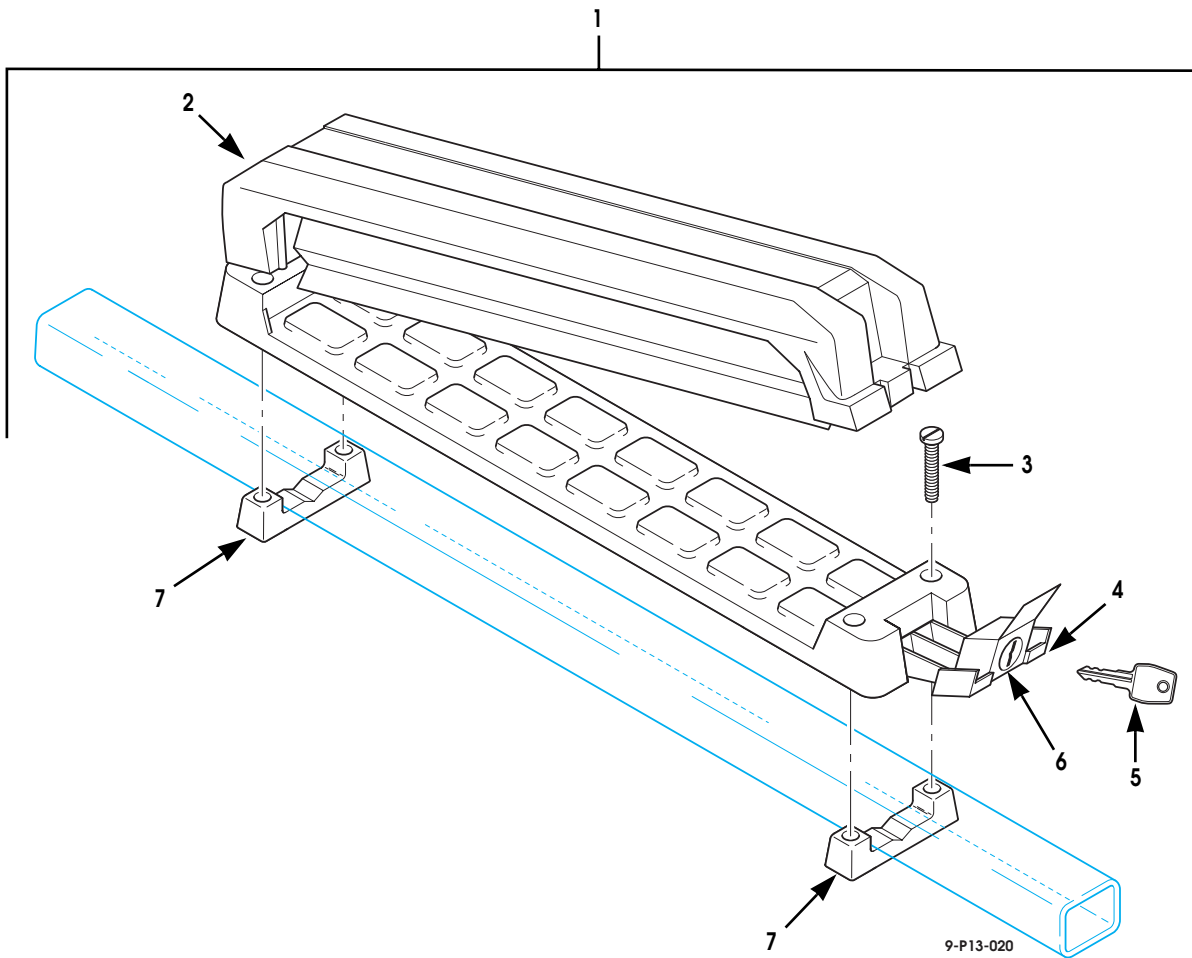

Figure 13-59. Ski Rack Kit.

# 2001 HUMMER PARTS CATALOG

## ACCESSORIES 13-121

ITEM	PART NUMBER	DESCRIPTION	QTY
		<b>Figure 13-59. Ski Rack Kit.</b>	
1	5745154	KIT, ski rack .....	1
2	S.I.K.	•CARRIER, ski .....	4
3	S.I.K.	•SCREW, clamp .....	8
4	S.I.K.	•LATCH .....	2
5	S.I.K.	•KEY .....	1
6	S.I.K.	•LOCK .....	2
7	5745181	•CLAMP .....	4

# 2001 HUMMER PARTS CATALOG

## 13-122 ACCESSORIES

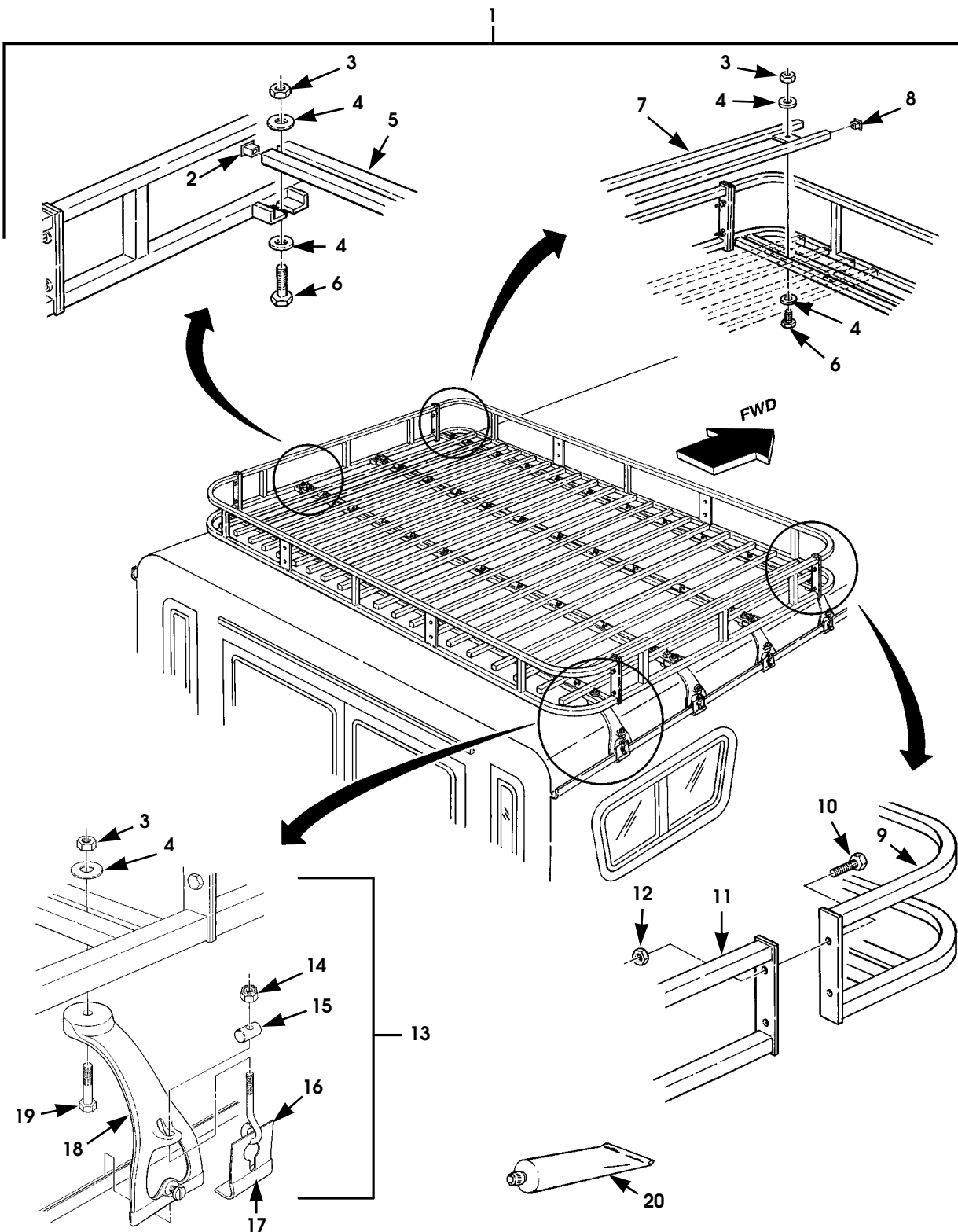

Figure 13-60. Roof Rack Kit, Steel, Square Tube.

P13-036.1

# 2001 HUMMER PARTS CATALOG

## ACCESSORIES 13-123

ITEM	PART NUMBER	DESCRIPTION	QTY		
			3'	6'	9'
		<b>Figure 13-60. Roof Rack Kit, Steel, Square Tube.</b>			
1	5743354	KIT, three-foot roof rack, . . . . . 89, 83, 84, 91	1		
1	5743213	KIT, six-foot roof rack . . . . . 83, 84, 91		1	
1	5743214	KIT, nine-foot roof rack. . . . . 84			1
2	5743261	•END CAP, crossbar . . . . .	8	16	20
3	S.I.K.	•LOCKNUT, nylon insert, 3/8"-16 . . . . .	24	52	66
4	S.I.K.	•WASHER, flat, 3/8 . . . . .	44	96	122
5	5743258	•CROSSBAR . . . . .	2	4	5
6	S.I.K.	•BOLT, 3/8 - 16 x 1 1/2, Gr5, Phos, roof rack. . . . .	20	44	56
7	5743262	•FLOOR SECTION, three-foot rack. . . . .	10		
7	5743263	•FLOOR SECTION, six-foot rack . . . . .		10	
7	5743264	•FLOOR SECTION, nine-foot rack. . . . .			10
8	5743265	•END CAP, floor section. . . . .	40	40	40
9	5743256	•RACK END ASSEMBLY . . . . .	2	2	2
10	S.I.K.	•BOLT, 5/16 - 18 x 1, Gr5, Phos. . . . .	8	8	8
11	5743260	•SIDE, three-foot rack . . . . .	2		
11	5743259	•SIDE, six-foot rack. . . . .		2	
11	5743257	•SIDE, nine-foot rack. . . . .			2
12	S.I.K.	•LOCKNUT, nylon Insert 5/16 - 18, Gr5 . . . . .	8	8	8
13	5743250	•CLAMP ASSEMBLY . . . . .	4	8	10
14	S.I.K.	••LOCKNUT, nylon insert, 1/4 - 20. . . . .	1	1	1
15	5743254	••SPACER, round, clamp . . . . .	1	1	1
16	5743253	••CLIP, clamp. . . . .	1	1	1
17	5743252	••BOOT, rubber, clamp. . . . .	1	1	1
18	5743251	••YOKE, clamp . . . . .	1	1	1
19	S.I.K.	•BOLT, 3/8 - 16 x 2, Gr5, Phos . . . . .	4	8	10
20	5743308	•GLUE, end cap . . . . .	1	1	1
		NOTE 1: SIX-FOOT ROOF RACK SHOWN.			

# 2001 HUMMER PARTS CATALOG

## 13-124 ACCESSORIES

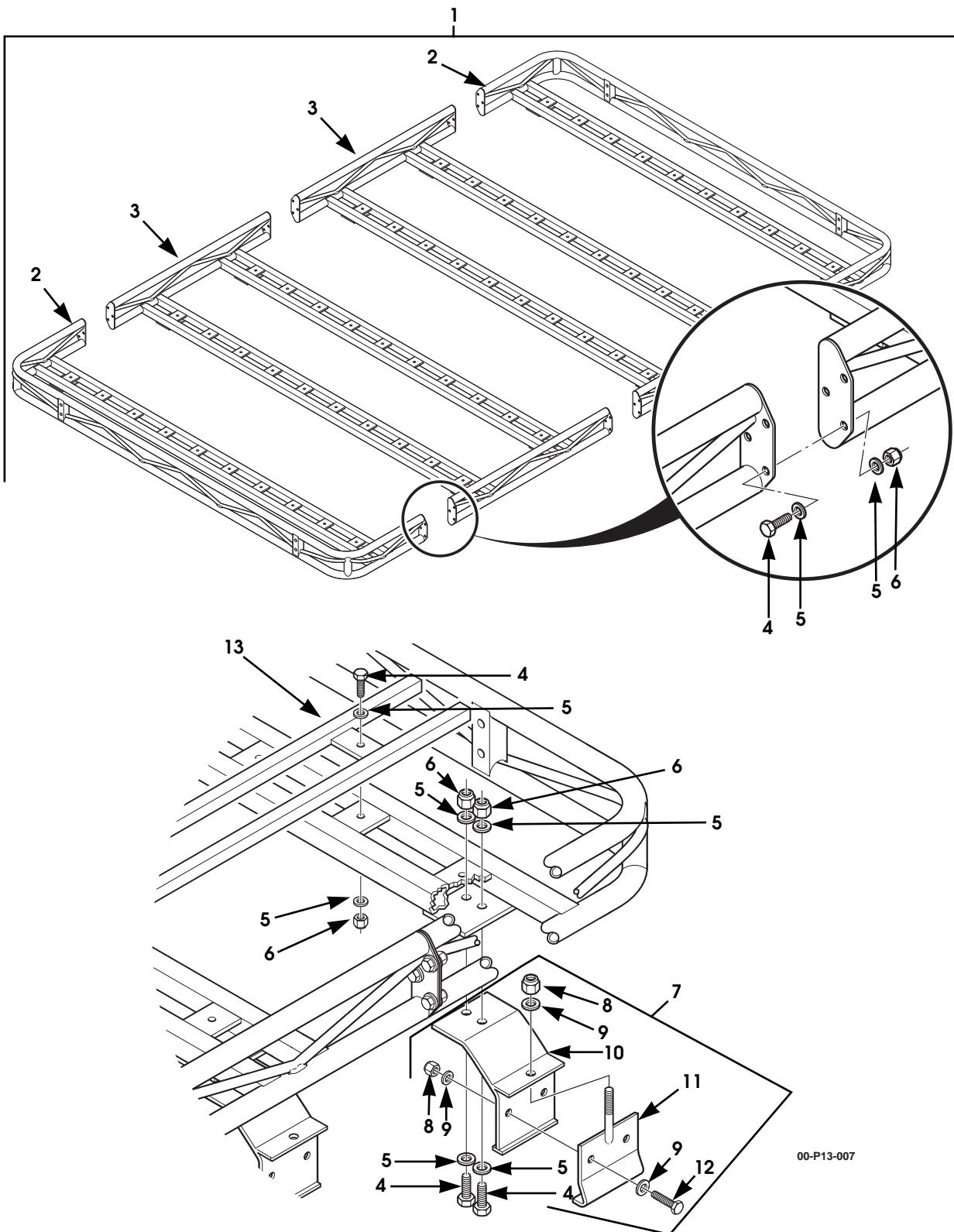

00-P13-007

Figure 13-61. Roof Rack Kit, Aluminum, Round Tube.

# 2001 HUMMER PARTS CATALOG

## ACCESSORIES 13-125

ITEM	PART NUMBER	DESCRIPTION	QTY		
			3'	6'	9'
		<b>Figure 13-61.</b> <b>Roof Rack Kit, Aluminum, Round Tube.</b>			
1	5745305	KIT, three-foot roof rack . . . . .	1		
		89, 83, 84, 91			
1	5745306	KIT, six-foot roof rack . . . . .		1	
		83, 84, 91			
1	5745307	KIT, nine-foot roof rack. . . . .			1
		84			
2	5745308	•RACK END ASSEMBLY . . . . .	2	2	2
3	5745315	•RACK CENTER ASSEMBLY . . . . .		1	2
4	S.I.K.	•BOLT, hex, 3/8-16, stainless. . . . .	34	68	102
5	S.I.K.	•WASHER, flat, 3/8-16, stainless. . . . .	68	136	204
6	S.I.K.	•LOCKNUT, nylon, 3/8-16, stainless. . . . .	34	68	102
7	5745314	•CLAMP ASSEMBLY . . . . .	4	8	12
8	S.I.K.	••LOCKNUT, nylon, 3/8-16, stainless. . . . .	3	3	3
9	S.I.K.	••WASHER, flat, 3/8-16, stainless. . . . .	4	4	4
10	S.I.K.	••BRACKET. . . . .	1	1	1
11	S.I.K.	••"L" BRACKET . . . . .	1	1	1
12	S.I.K.	••BOLT, hex, 3/8-16, stainless . . . . .	2	2	2
13	5745310	•FLOOR RAIL ASSEMBLY, 3-foot. . . . .	10		
13	5745311	•FLOOR RAIL ASSEMBLY, 6-foot. . . . .		10	
13	5745312	•FLOOR RAIL ASSEMBLY, 9-foot. . . . .			10
	5745313	•END CAP, floor rail (not illustrated) . . . . .	40	40	40
	6011541	•LABEL, warning, 3-foot roof rack (not illustrated) . . . .	1		
	6011544	•LABEL, warning, 6 and 9 foot roof racks (not illustrated)		1	1
	S.I.K.	•TAPE, foam . . . . .	1	1	1
	6011540	LABEL, warning, Arabic, 3-foot roof rack (not illustrated)	1		
	6011543	LABEL, warning, Arabic, 6 and 9 foot roof racks. . . . .		1	1
		(not illustrated)			
	6011539	LABEL, warning, English/French 3-foot roof rack . . . . .	1		
		(not illustrated)			
	6011542	LABEL, warning, English/French 6 and 9 foot roof racks		1	1
		(not illustrated)			
		NOTE 1: NINE-FOOT ROOF RACK SHOWN.			



# 2001 HUMMER PARTS CATALOG

## 13-126 ACCESSORIES

ITEM	PART NUMBER	DESCRIPTION	QTY
		<b>Bulk</b>	
1	CPR104420-2	TUBING, nylon, 3/8" O.D. . . . . .	A/R
2	CPR104420-3	TUBING, nylon, 1/2" O.D. x 3/8" I.D. . . . . .	A/R
3	CPR104420-6	TUBING, nylon, bulk, 1/8" O.D. x 50' . . . . .	A/R
4	M13486/111	ELECTRICAL WIRE, 4 GAUGE . . . . .	A/R
5	MA20722026	TUBING, nylon, 1/4" I.D. . . . . .	A/R
6	5740928	HOSE, rubber, bulk, 1/2" O.D. x 1/4" I.D. x 100 feet long .	A/R
7	5740929	HOSE, rubber, bulk, 7/8" O.D. x 5/8" I.D. x 50 feet long .	A/R
8	5741064	HOSE, rubber, bulk, 1" O.D. x 11/16" I.D. x 50 feet long .	A/R
9	5741067	HOSE, nonmetallic, 5/8" O.D. x 3/8" I.D. x 25 feet long .	A/R
10	5741068	HOSE, NONMETALLIC, 1/2" O.D. x 1/4" I.D. x 25 feet long .	A/R
11	5741079	NYLON TUBE 3/16" X 250' ROLL . . . . .	A/R
12	5741163	HOSE, rubber, bulk, 1/2" O.D. x 1/4" I.D. x 25 feet long	A/R
13	5741209	HOSE, rubber, bulk, 5/8" O.D. x 3/8" I.D. x 25 feet long .	A/R
14	5741210	HOSE, rubber, bulk, 1/2" O.D. x 1/4" I.D. x 50 feet long .	A/R
15	5741211	HOSE, rubber, bulk, 3/8" O.D. x 3/16" I.D. x 50 feet long .	A/R
16	5741214	EDGE PROTECTOR, 3/8" x 9/32" x 80 feet long . . . . .	A/R
17	5743023	HOSE, air duct, bulk, 2 1/2" I.D. x 18 feet long . . . . .	A/R
18	5743169	HOSE, plastic, drain, 1/2" O.D. x 3/8" I.D. x 4 feet long .	A/R
19	5743540	HOSE, air duct, bulk, 3/4" I.D. x 50 feet long . . . . .	A/R
20	5743541	HOSE, air duct, bulk, 1 1/2" I.D. x 25 feet long . . . . .	A/R
21	5743542	DUCT HOSE, flexible, 2" O.D. x 50 feet . . . . .	A/R
22	5743584	HOSE, bulk, drain, 7/16" O.D. x 3/8" I.D. x 50 feet long	A/R
23	5744321	SEAL, door, 50 foot roll . . . . .	A/R
24	5744322	SEAL, body, 50 foot roll . . . . .	A/R
25	5937189	TAPE, PVC foam, 35' roll . . . . .	A/R
26	6000871	SEAL, door drip rail . . . . .	A/R
27	6001808	SEAL, door trim, 250' roll . . . . .	A/R
28	5744138	SEAL, door trim, 12' roll . . . . .	A/R
29	6006217	SEALING TAPE, bulk, 150-ft roll . . . . .	A/R
30	6006218	EDGE SEAL, bulk, vertical doors, 500-ft roll . . . . .	A/R
31	6006219	DOOR SEAL, bulk, vertical doors, 500-ft roll . . . . .	A/R
32	6008053	TAPE, Butyl foam core, bulk, 720-ft long roll . . . . .	A/R
33	6009348	EDGE GUARD, bulk, 150-foot roll . . . . .	A/R
34	6009706	DOOR SEAL, bulk, vertical doors, 500-ft roll . . . . .	A/R

# 2001 HUMMER PARTS CATALOG

## ACCESSORIES 13-127

ITEM	PART NUMBER	DESCRIPTION	YEAR
		<b>Commercial Manuals</b>	
	5714134	OWNER'S MANUAL .....	1993
	5714154	OWNER'S MANUAL .....	1994
	5714158	OWNER'S MANUAL .....	1995
	5714158G	OWNER'S MANUAL, GASOLINE .....	1995
	5744368	OWNER'S MANUAL, CANADIAN SUPPLEMENT .....	1995
	5744369	OWNER'S MANUAL, G.C.C SUPPLEMENT .....	1995
	5744380	OWNER'S MANUAL .....	1996
	5744613	OWNER'S MANUAL .....	1997
	5744845	OWNER'S MANUAL .....	1998
	5744974	OWNER'S MANUAL .....	1999
	5745157	OWNER'S MANUAL .....	2000
	5745277	OWNER'S MANUAL .....	2001
	5744168	OWNER'S MANUAL KIT, SEE NOTE 1 .....	1995
	5744676	OWNER'S MANUAL KIT, SEE NOTE 2 .....	1997
	5744861	OWNER'S MANUAL KIT, SEE NOTE 3 .....	1998
	5744973	OWNER'S MANUAL KIT, SEE NOTE 4 .....	1999
	5745156	OWNER'S MANUAL KIT, SEE NOTE 5 .....	2000
	5745276	OWNER'S MANUAL KIT, SEE NOTE 6 .....	2001
	5744632	MAINTENANCE BOOKLET .....	1997
	5744692	MAINTENANCE BOOKLET (for all years except 1997) .	
	5714155	PARTS MANUAL .....	1992/93/94
	5714159	PARTS MANUAL .....	1995
	5744381	PARTS MANUAL .....	1996
	5744614	PARTS MANUAL .....	1997
	5744846	PARTS MANUAL .....	1998
	5744976	PARTS MANUAL .....	1999
	5745158	PARTS MANUAL .....	2000
	5745278	PARTS MANUAL .....	2001
	5714156	SERVICE MANUAL .....	1992/93/94
	5714160	SERVICE MANUAL .....	1995
	5744382	SERVICE MANUAL .....	1996
	5744615	SERVICE MANUAL .....	1997
	5744847	SERVICE MANUAL .....	1998
	5744975	SERVICE MANUAL .....	1999
	5745159	SERVICE MANUAL .....	2000
	5745279	SERVICE MANUAL .....	2001
	5745280	LABOR TIME GUIDE .....	1992-2001

# 2001 HUMMER PARTS CATALOG

## 13-128 ACCESSORIES

ITEM	PART NUMBER	DESCRIPTION	YEAR
		<b>Commercial Manuals (Continued)</b>	
	5744618	POLICIES AND PROCEDURES MANUAL .....	1997/98/99
	5743423	SPECIAL EQUIPMENT APPLICATION GUIDE .....	1993/1994
	5714162	SPECIAL EQUIPMENT APPLICATION GUIDE .....	1995
	5744522	SPECIAL EQUIPMENT APPLICATION GUIDE .....	1996
	5744617	SPECIAL EQUIPMENT APPLICATION GUIDE .....	1997/1998
	5744644	VIDEO, OFF-ROAD DRIVING.....	1993-98
	5745035	VIDEO, OFF-ROAD DRIVING.....	1999
	5744619	VIDEO, 1-PIECE WHEEL .....	1996-1999
	5745044	CD ROM, PARTS AND SERVICE MANUALS .....	1995/1996
	5745045	CD ROM, PARTS AND SERVICE MANUALS .....	1997/1998
	5744978	CD ROM, PARTS AND SERVICE MANUALS .....	1999/2000
	5744979	CD ROM, PARTS AND SERVICE MANUALS .....	2001
		NOTE 1: KIT INCLUDES 5714158, 5714158G, AND A ZIP-PERED CASE.	
		NOTE 2: KIT INCLUDES 5744613, 5744632, AND A ZIP-PERED CASE.	
		NOTE 3: KIT INCLUDES 5744845, 5744692, AND A ZIP-PERED CASE.	
		NOTE 4: KIT INCLUDES 5744974, 5744692, AND A ZIP-PERED CASE.	
		NOTE 5: KIT INCLUDES 5745157, 5744692, AND A ZIP-PERED CASE.	
		NOTE 6: KIT INCLUDES 5745277, 5744692, AND A ZIP-PERED CASE.	

# 2001 HUMMER PARTS CATALOG

## ACCESSORIES 13-129

COLOR DESCRIPTION	AMG CODE	MFG CODE	NCP CODE	PPG PRIMER	AMG TOUCH UP 2 oz. bottle	AMG TOUCHUP 12 oz.spray
WHITE GLOSS	W8	DCC-8378	N5611A	DP90LF	5744357	5744358
SILVER METALLIC	S15	DCC-4494	N/A	DP50LF	5744359	5744360
BRIGHT WHITE	W14	DCC-4185	N/A	DP50LF	5744366	5744367
BLACK GLOSS	B9	DCC-9000	N/A	DP90LF	5744182	5744181
TAN GLOSS	T11	DCC-101794	N5316A	DP90LF	5744184	5744183
COMPETITION YELLOW	Y20	DFHS-4266	N/A	DP50LF	5744895	5744896
CANDY APPLE RED	R19	DFHS-71698	N/A	DP50LF	5744897	5744898
MESA DUSK CARMEL	C22	PPG-5228	N/A	DP50LF	5745060	5745061
METALLIC PEWTER	P33	PPG-5377	N/A	DP50LF	5745283	5745282
WOODLAND GREEN	G23	PPG-4976K	N/A	DP50LF	5745285	5745284
OCEAN BLUE METALLIC	L24	PPG-15650	N/A	DP50LF	5745367T	5745366S

NOTE: All paints listed above can be used with PPG Top coat Enhancer Code DX73. Top coat Catalysts are as follows: PPG Code DU6, NCP Code N1433B. PPG Primer Catalyst is code DP402LF. All listed paints can use PPG reducer, Code DT870.

